



Messerschmitt BF.109D Poland, 1939

The Messerschmitt Bf 109's versatility and time in service with both the German Luftwaffe and other foreign air forces, numerous variants were produced over the eight years of service with the Luftwaffe and even more were produced by its foreign service.

The Me 109D (codnamed "DORA") was the first major production model of the Messerschmitt Bf 109 fighter.

The D - 1 as eventually produced was thus very similar to the earlier "C" - series machines. Minor changes were made to the tail wheel, and the airframe had been slightly strengthened in preparation for the DB 600 engine. The 109D was armed with four MG 17 machine guns, two in the wings and above the engine cowling.

The Luftwaffe used two Air Fleets for the war on Poland - Luftflotte 1 "Ost" in the North (gen A.Kesselring) and in the south Luftflotte 4 Sudost (gen A.Lohr).

Overall, the Luftwaffe fielded 342 Bf 109 fighters. Two units were equipped with Bf 109Ds - I./JG 21 (Hptm M.Metting), 39 Bf109d on strength, in the North and I./ZG 2 (Hptm J.Genzen - 1st Lufwaffe Ass of polish campaign'39) 45 Bf109C and D in the South.

It entered production in the spring of 1938. A total of 647 Bf 109D were built.

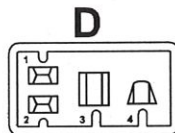
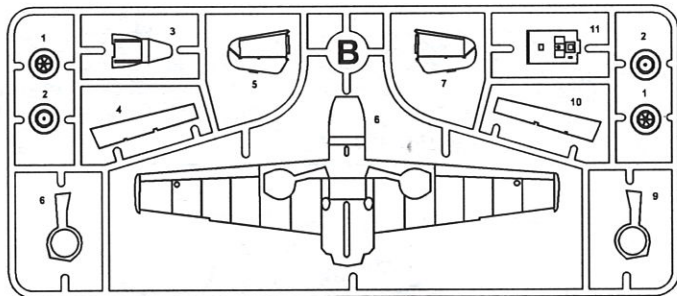
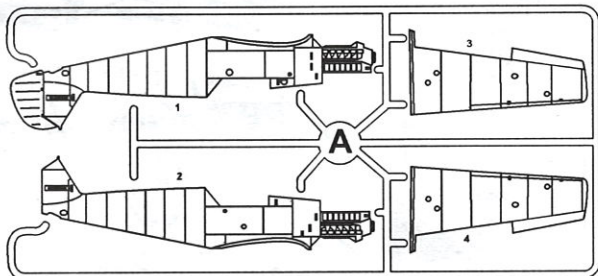

THE CONDITIONAL DENOTATION

УСЛОВНЫЕ ОБСМНЧЕНИЯ



BE CAREFUL
ОСТОРОЖНО



DON'T CEMENT
НЕ КЛЕИТЬ



REMOVE
РЕЗАТЬ



SYMMETRICAL
СИММЕТРИЧНО



MAKE TWO
УДОБИТЬ



OPTIONAL
НЕОБЯЗАТЕЛЬНО



BEND
СОГНУТЬ



OPEN WHOLE
СВЕРЛИТЬ



CEMENT
КЛЕИТЬ



VARIANTS
ВЫБОР ВАРИАНТА

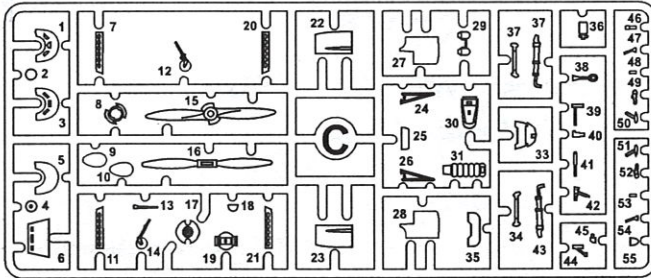

Resin



ASSEMBLY MANUAL

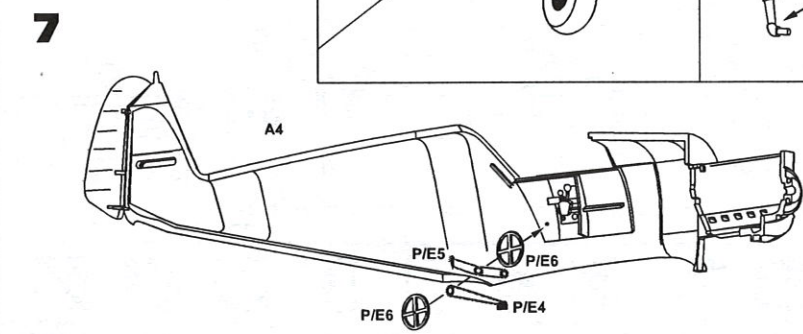
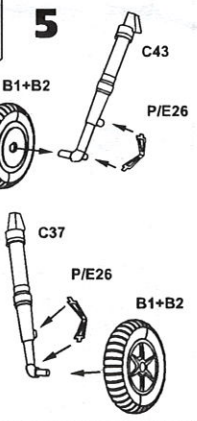
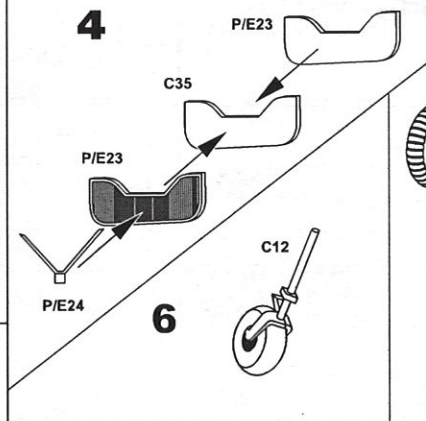
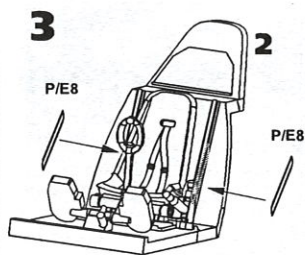
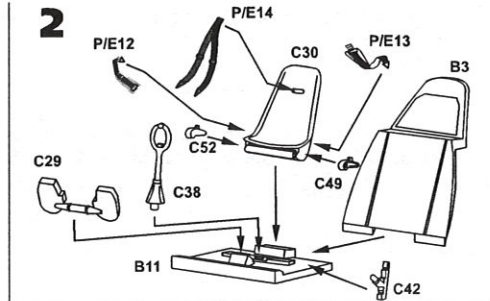
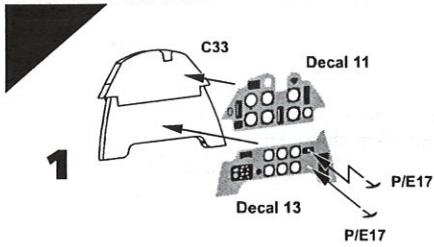

8

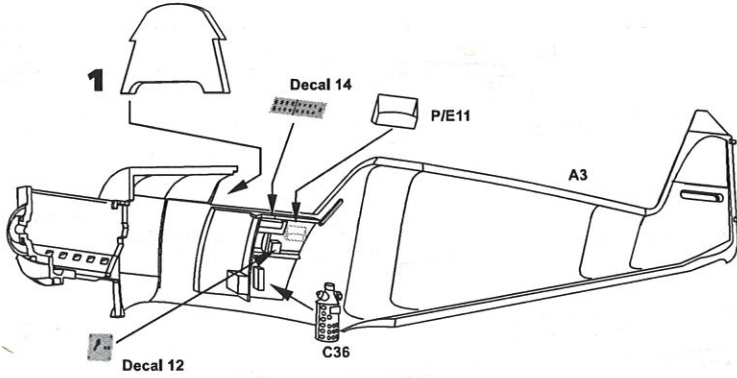

9

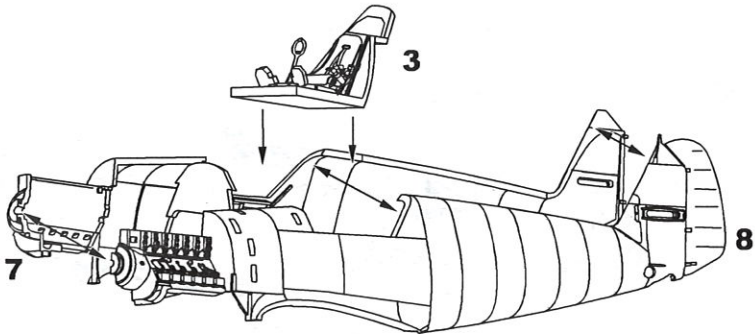

10

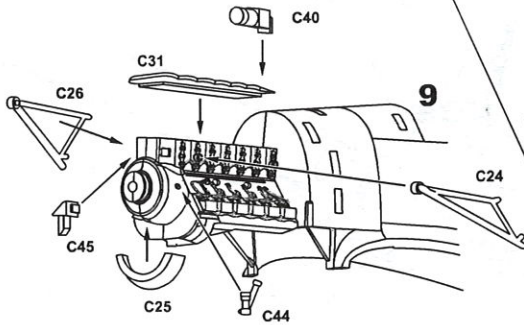

11

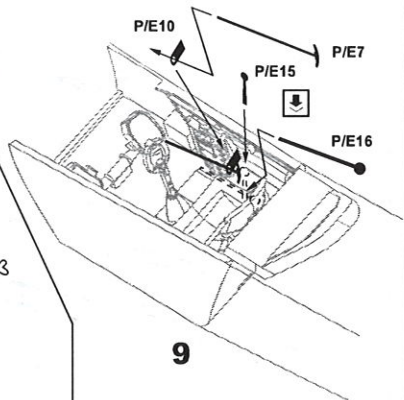

12

10

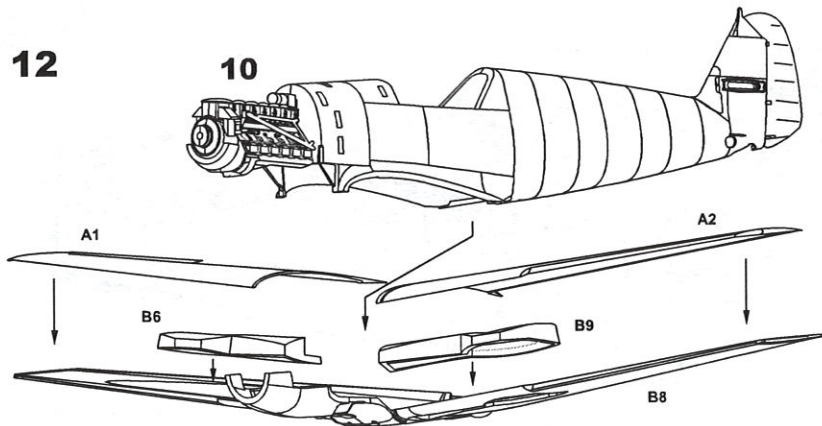

13

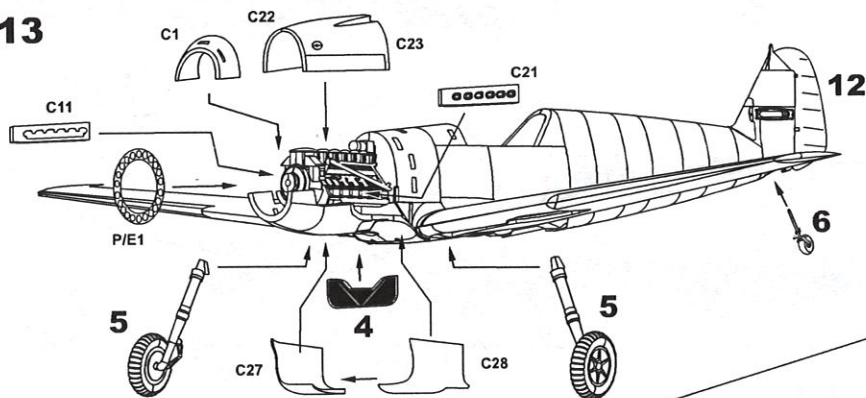

14

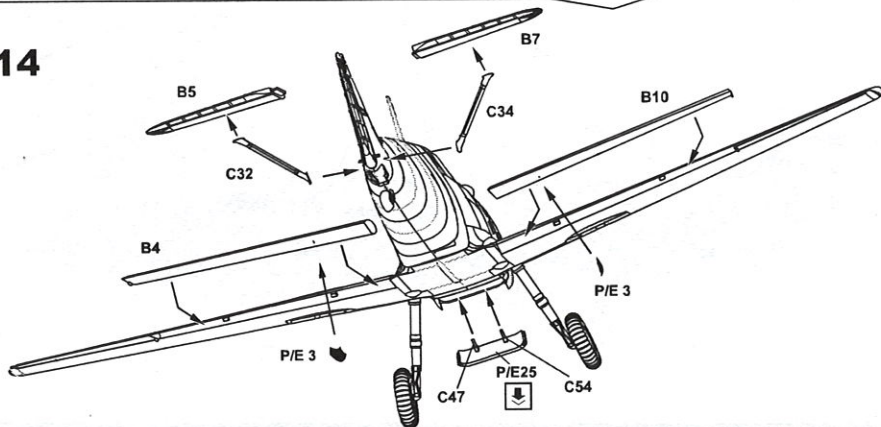

15

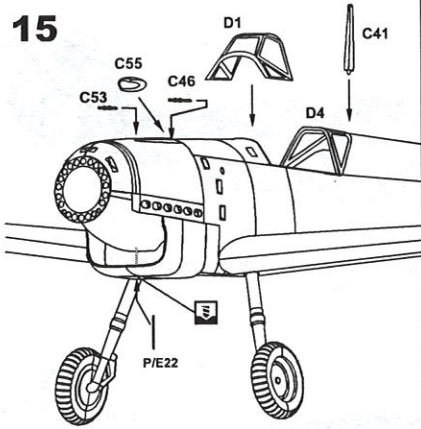

16

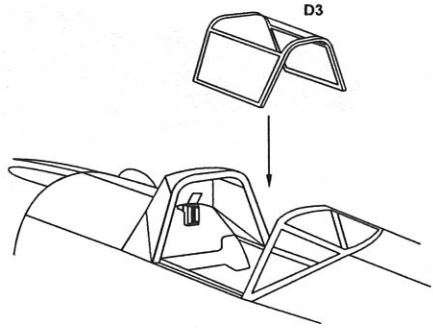

17

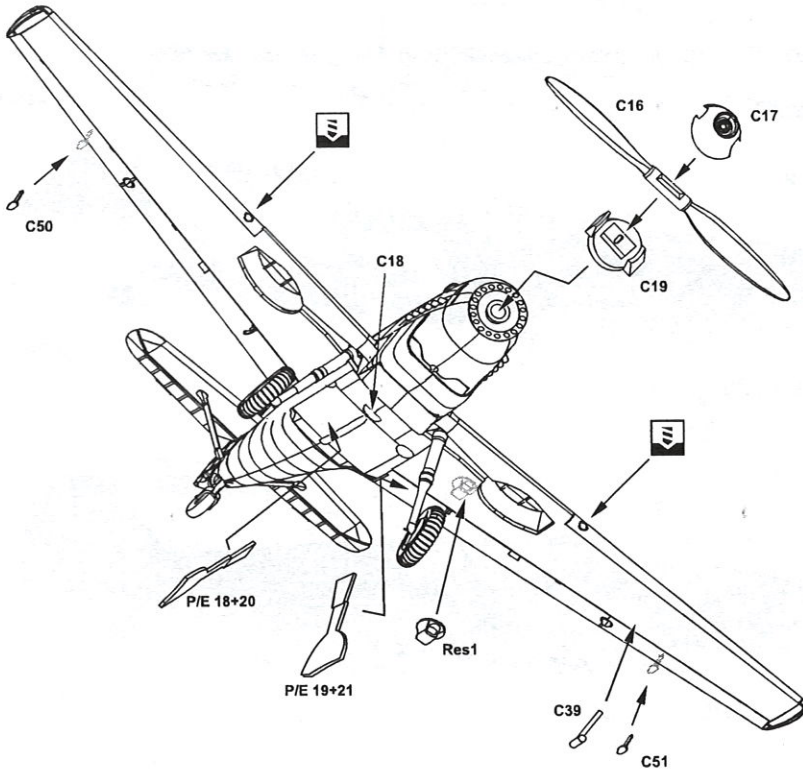

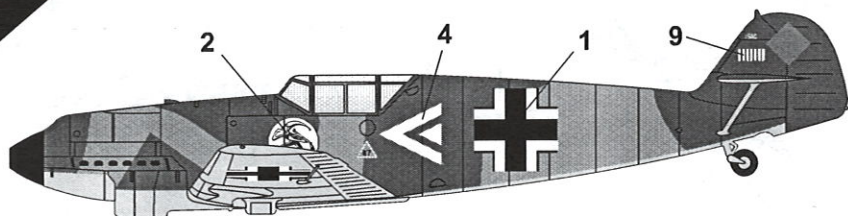

Bf.109D-1 I./JG 102, Hauptmann Johannes Gentzen Bernburg, 17 septembre 1939

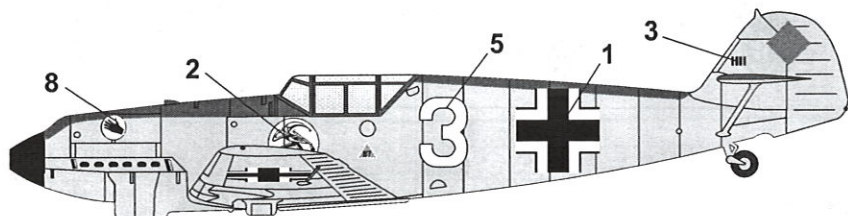

Bf.109D-1 I./JG 102, Unteroffizier Schuch Bernburg (4 vic.), 17 septembre 1939

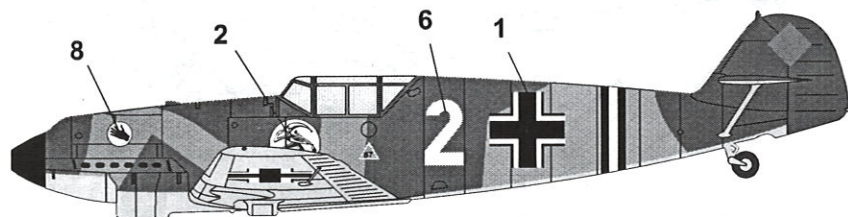

Bf.109D I./ZG 2, 1939

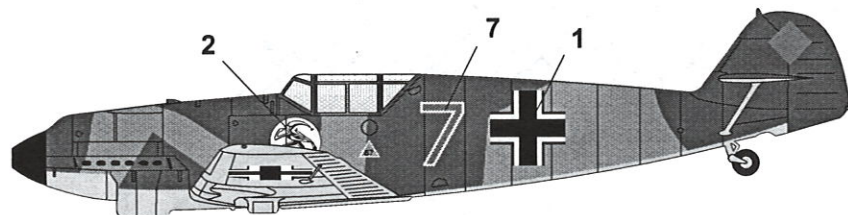

Bf.109D-1 2./JG 102, 1939

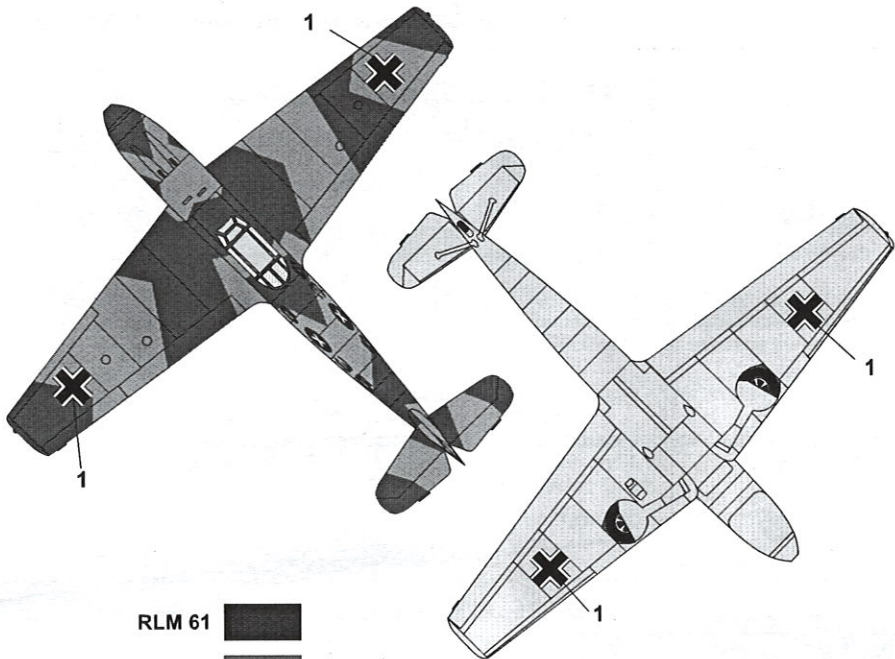

- RLM 61 
- RLM 70 
- RLM 65 
- RLM 62 

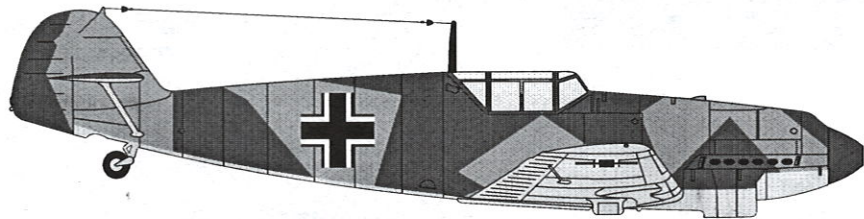

Mask

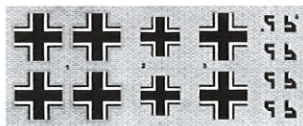
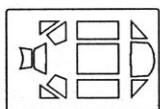

x2

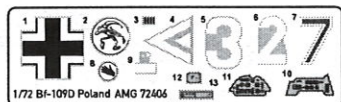

Availability and selection of items designations verify by the photos!

