

## Republic RF-84F Thunderflash



## Republic RF-84F Thunderflash

The RF-84F Thunderflash was derived from the F-84 Thunderjet, one of the early jet powered straight-wing fighters, which first flew in 1946. Although sharing the same F84 designation, the RF-84F Thunderflash, like the F-84F Thunderstreak, had a swept wing and tail surfaces. Two F-84 aircraft were modified with swept wings, the YF-84F (F-84F) keeping the nose intake, and the YFR-84F (RF-84F) adopting wing-root intakes. These wing-root intakes reduced thrust making the aircraft unsuitable as a fighter, but the long clean nose made it ideal for reconnaissance, the nose containing up to 15 cameras. A computerised control adjusted settings for speed, altitude, and light. A 'periscope' or view-finder display allowed the pilot to visualise what the vertical camera would see, and an audio recorder let the pilot narrate proceedings. It was armed with 4 x 0.5 inch machineguns at the wing-roots. Completed in 1952, it did not become operational until 1954. Along with the F-84F, the RF-84F suffered from the same construction delays, powerplant and other problems. Production models had the sliding canopy changed to an upward hinged unit. Later aircraft had further modifications such as wing-fences, spoilers etc to improve handling and performance. The aircraft usually flew with 2 underwing fuel tanks, which also contained Photoflash ejectors for night operations.

Retired from service in 1957, but reactivated in 1961, finally retired from the Air National Guard in 1972.

The RF-84F was operated by other nations such as West Germany, Belgium, Denmark, Netherlands, Italy, and France. French aircraft operated from Cyprus in support of Anglo/French forces during operation Musketeer - the Suez Crisis;

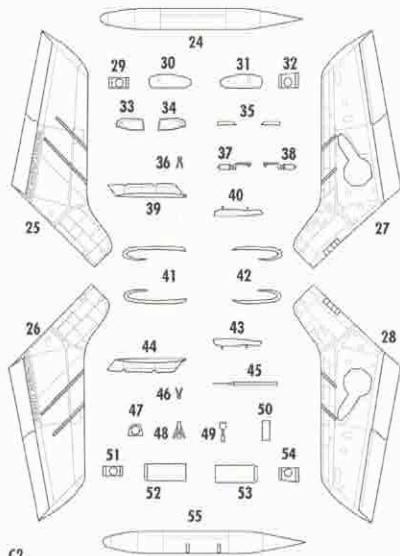
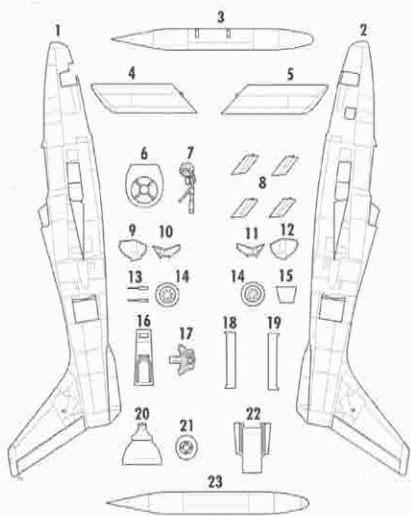

BARVA/COLOR	
A	Černá/Black
B	Interierová zelená/ Zinc chromate
C	Stříbrná/Silver
D	Hliník/Aluminium
E	Světlé šedá/ Light Grey
F	Červená/Red
G	Žlutá/Yellow
H	Zelená/Green
I	Černošedá/ Tyre Black
J	Špinavý hliník/ Dirty Aluminium
K	Chromová/ Chrome
L	Hnědá/Brown
M	Kovová/Gun metal
N	Olive

URETHAN



CLEAR

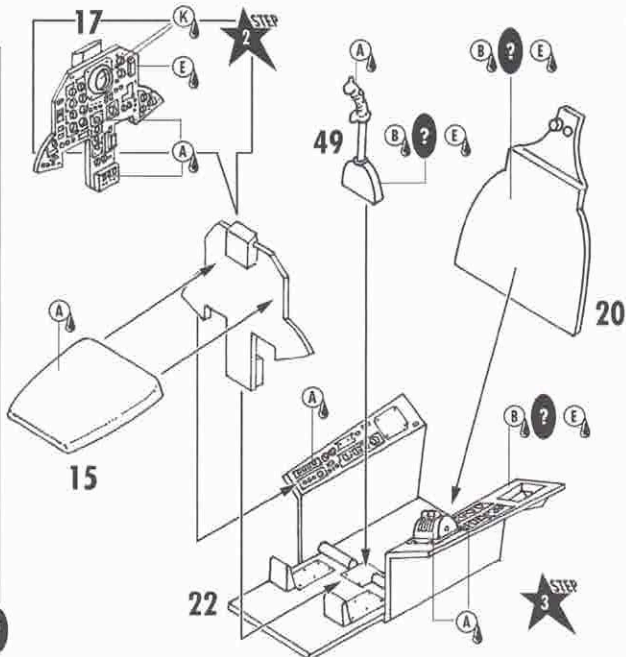
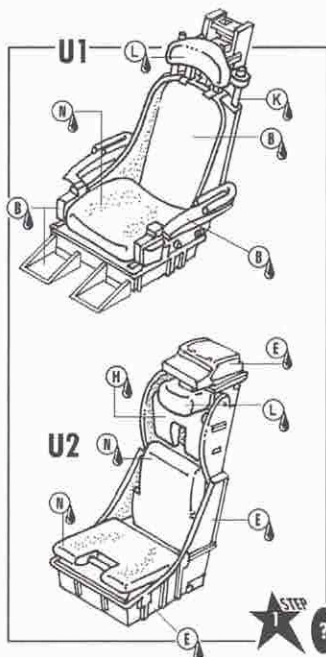
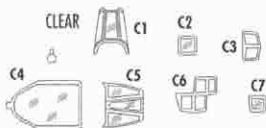

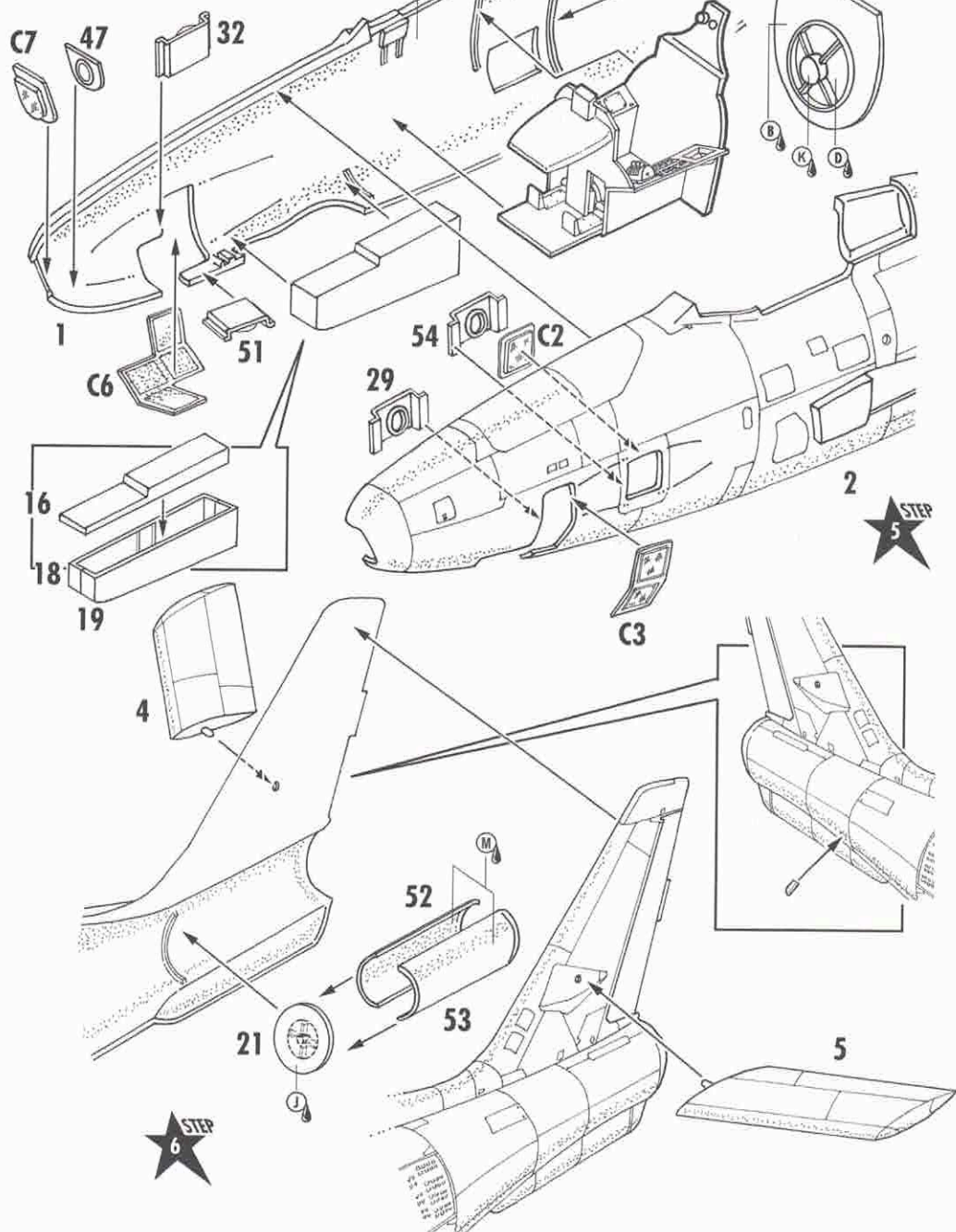



STEP  
11

9/12

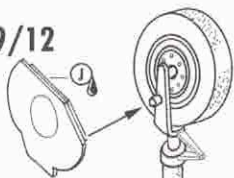

33/34



10/11



13

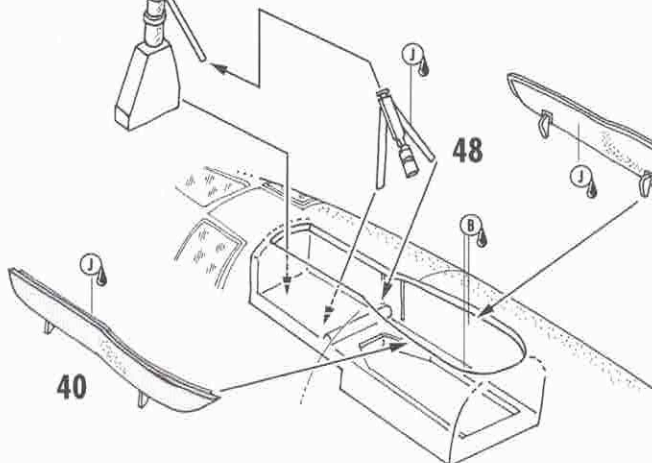
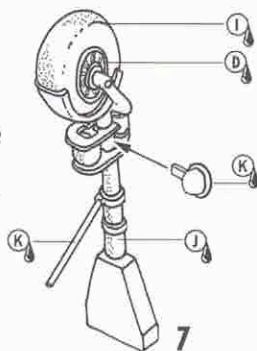

13

STEP  
13STEP  
12

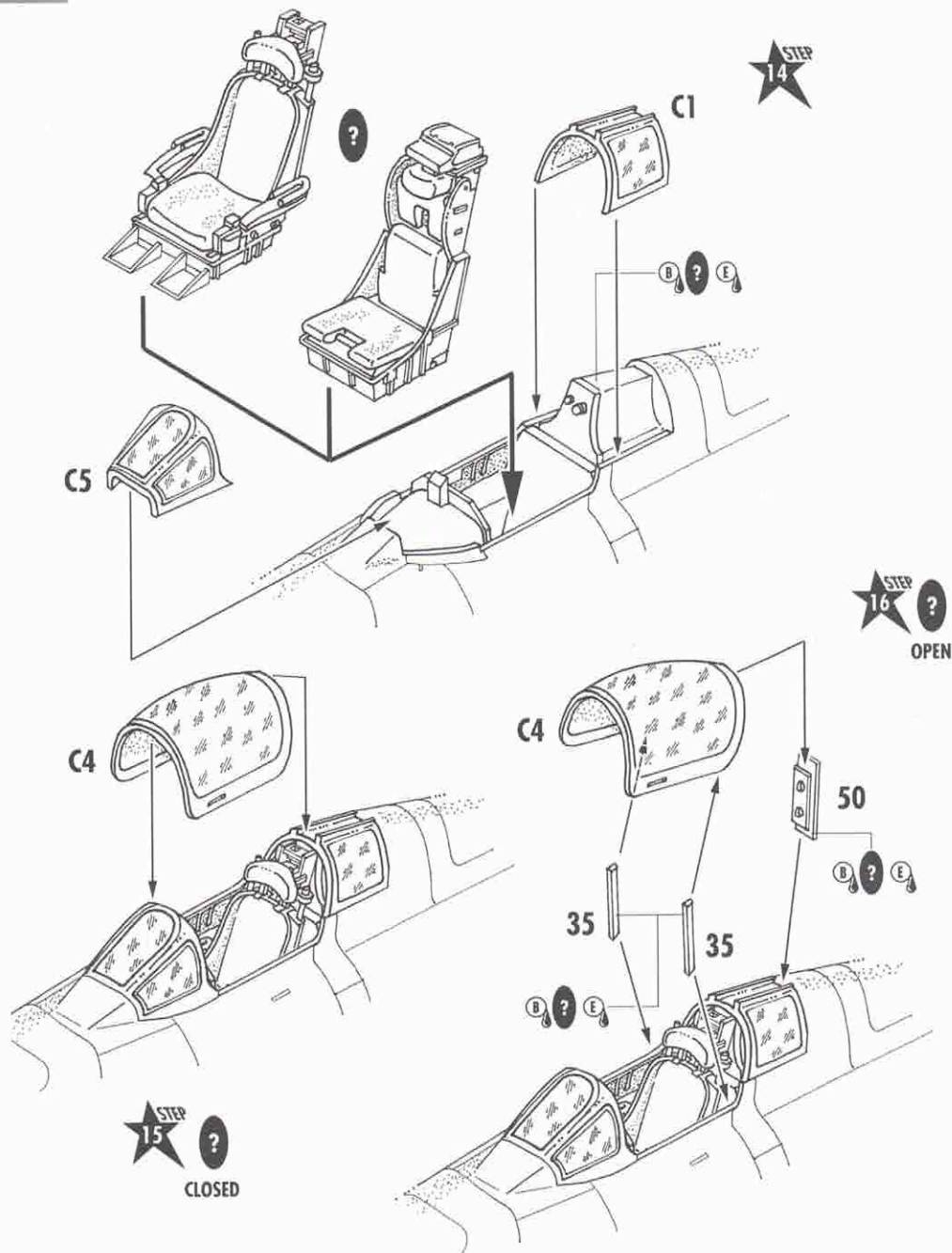

*RF-84F Stencil data (Belgium AF)*

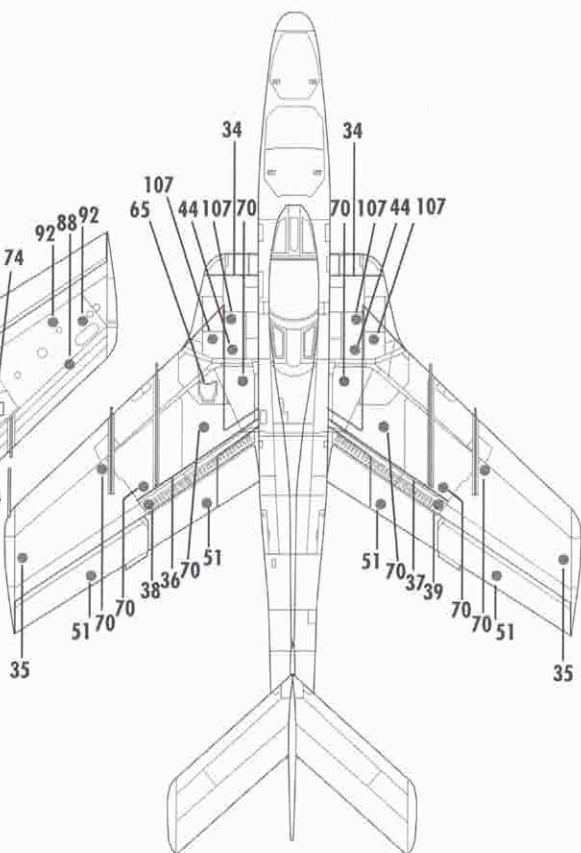
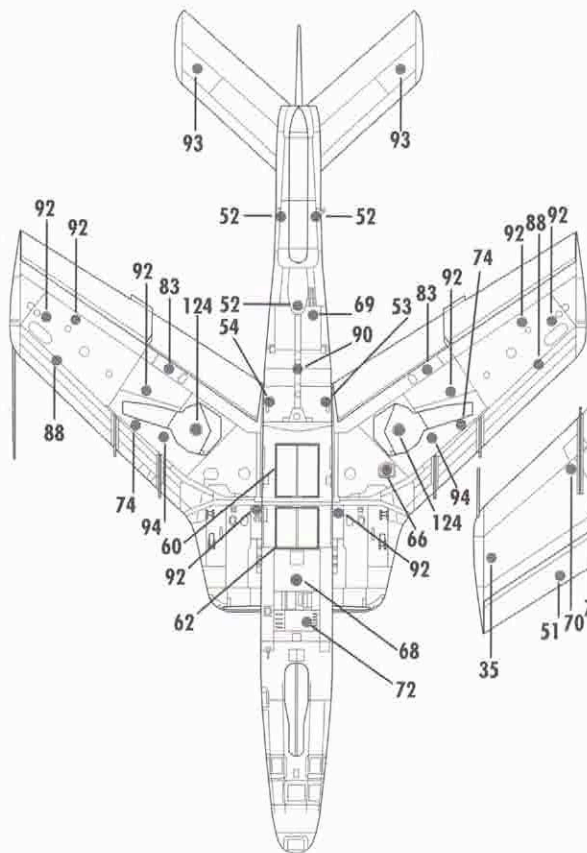
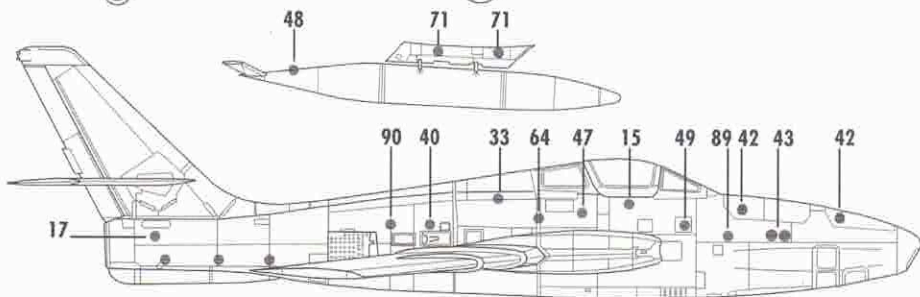
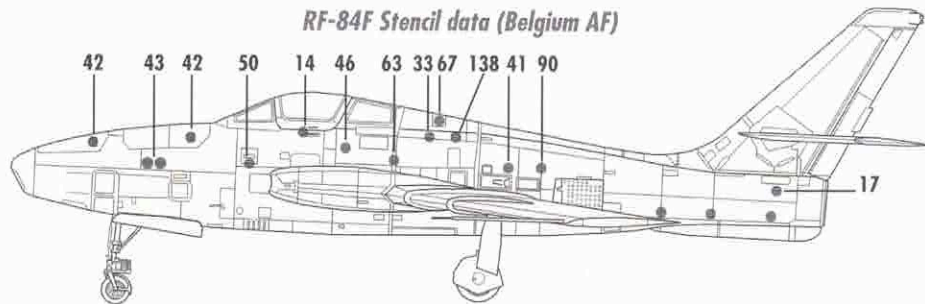

*RF-84F Stencil data (USAF, Italy AF, Netherland AF)*

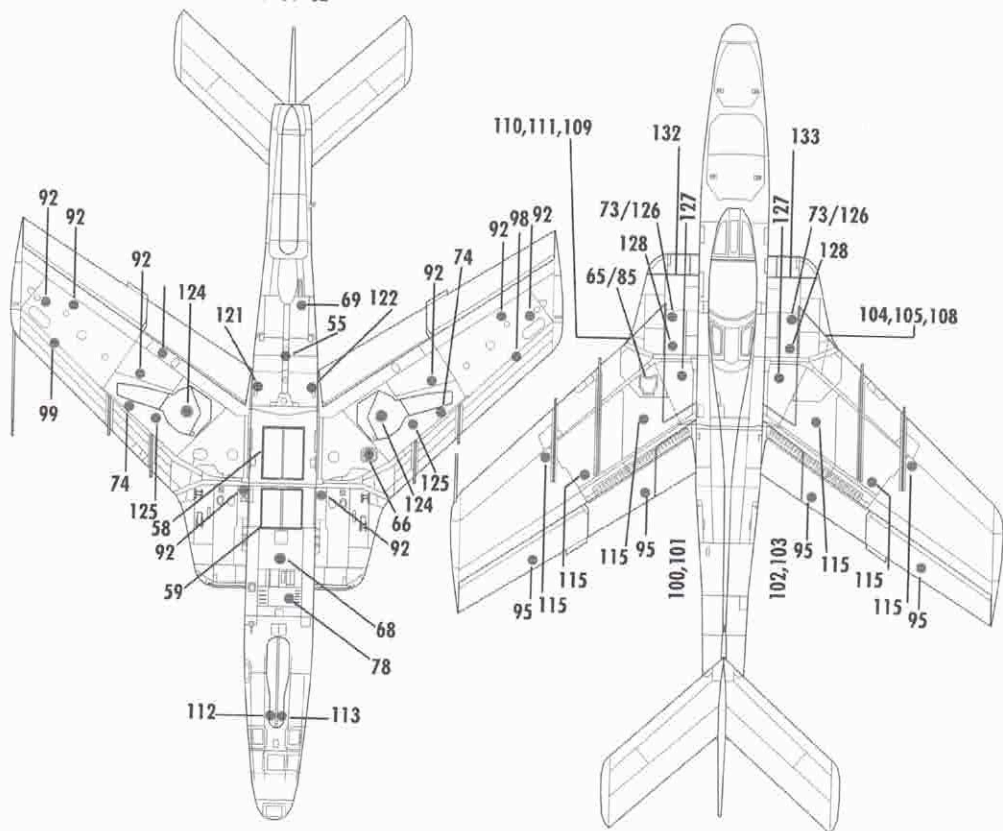
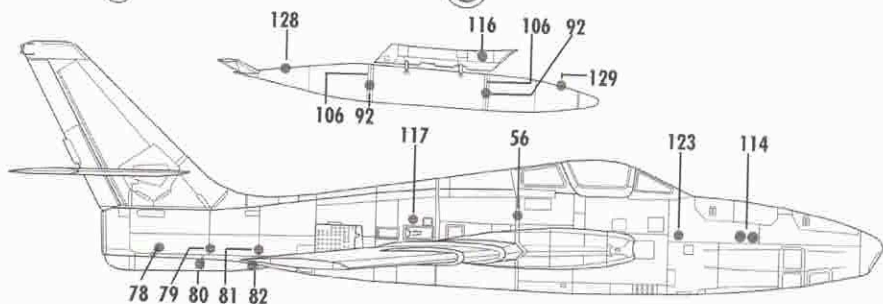
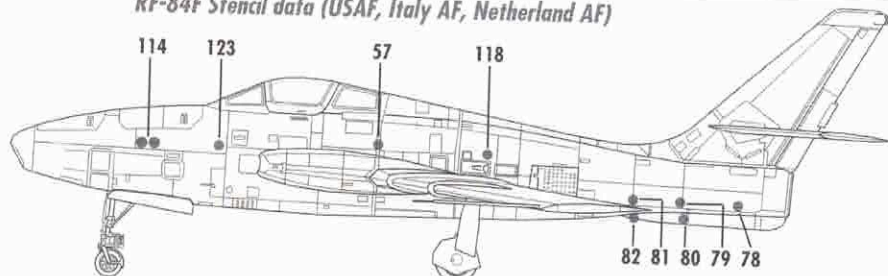



# RF-84F Thunderflash

RF-84F Thunderflash, 42e Smaldeel, AB at Bleret (Liege), Belgium, 1970

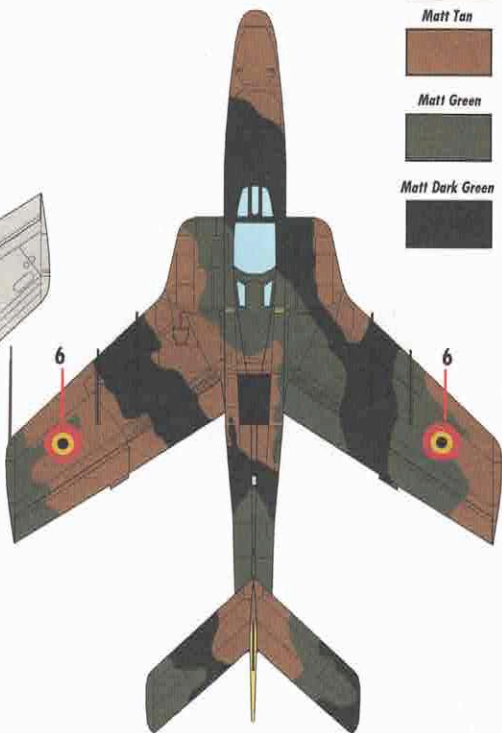
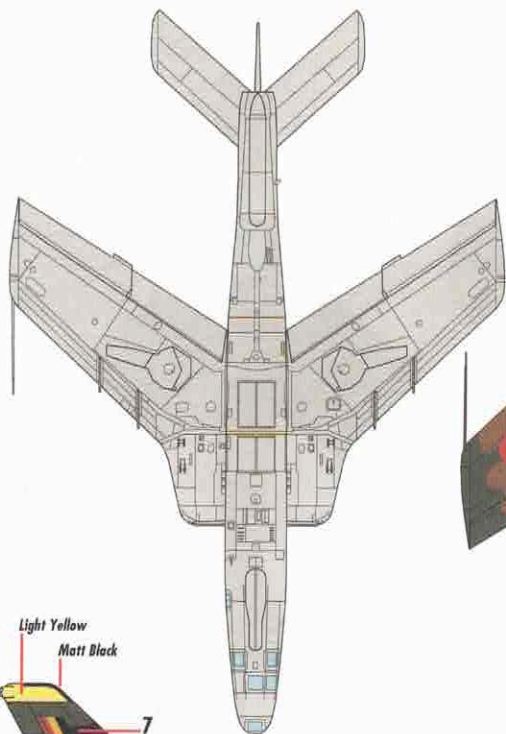

Matt Light Gray



Matt Tan



Matt Green



Matt Dark Green

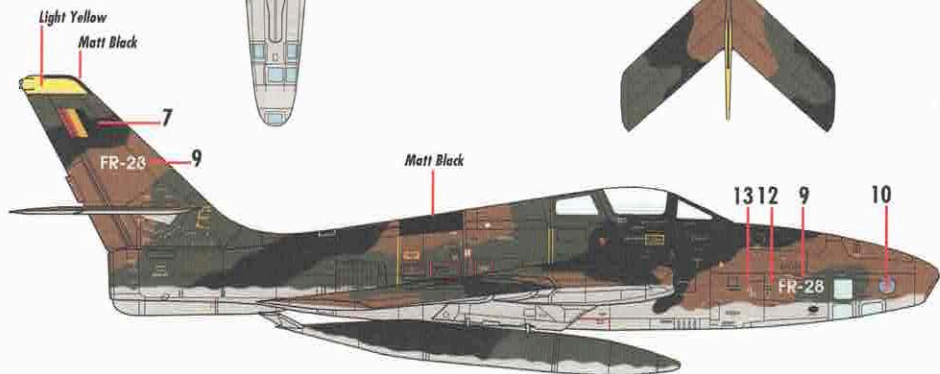

# RF-84F Thunderflash

RF-84F Thunderflash, No.306 Rec Squadron, Deelen AB, Koninklijke Luchtmacht, Netherlands, 1961

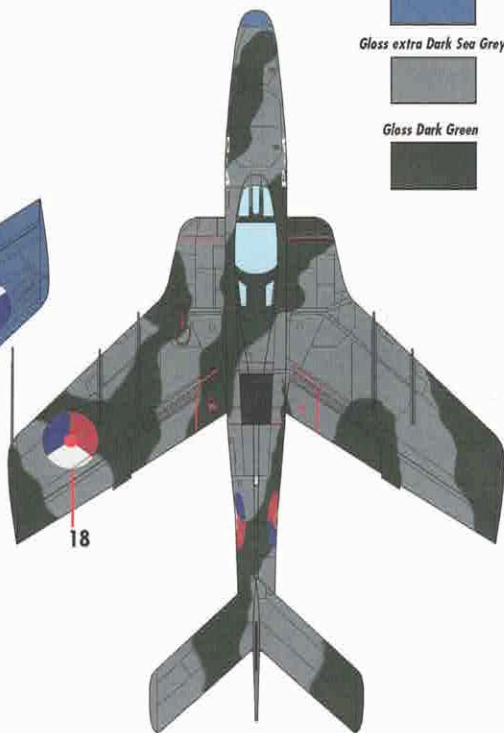
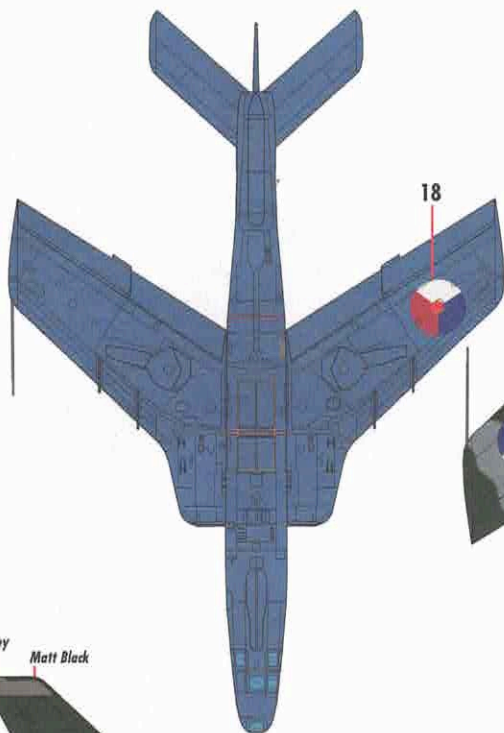
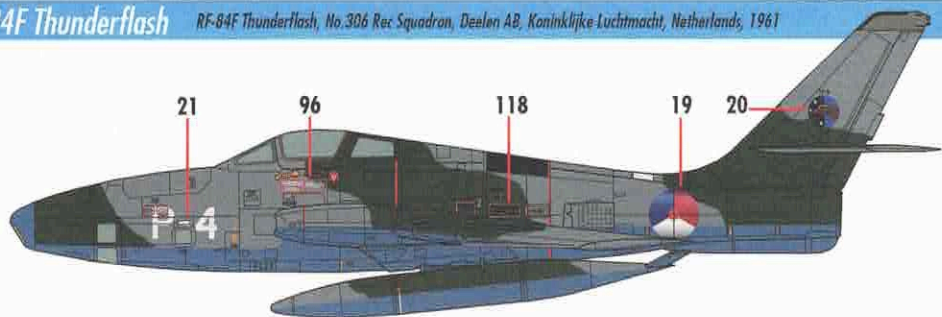

PRU Blue



Gloss extra Dark Sea Grey



Gloss Dark Green

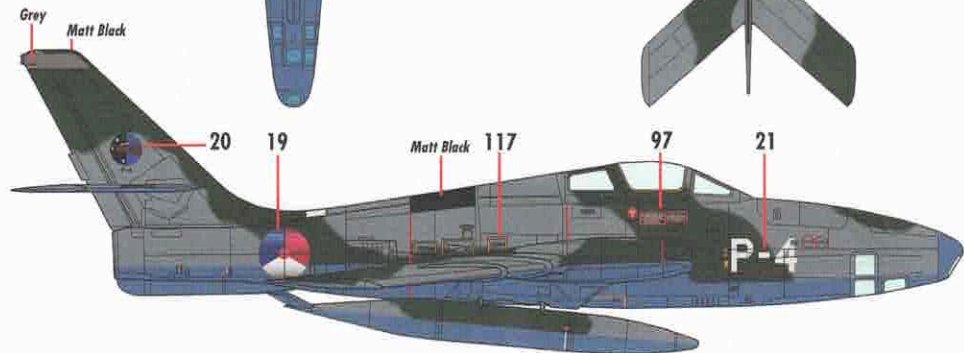

# RF-84F Thunderflash

RF-84F Thunderflash, 132 Gruppo 3 Aerobrigata, Villafranca AB Aeronautica Militare, Italy 1968



Overall natural metal finish



Gloss Dark Red



Matt Olive Drab

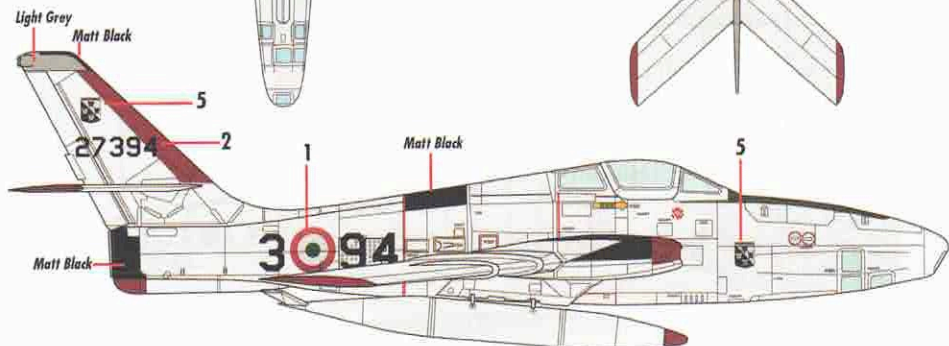
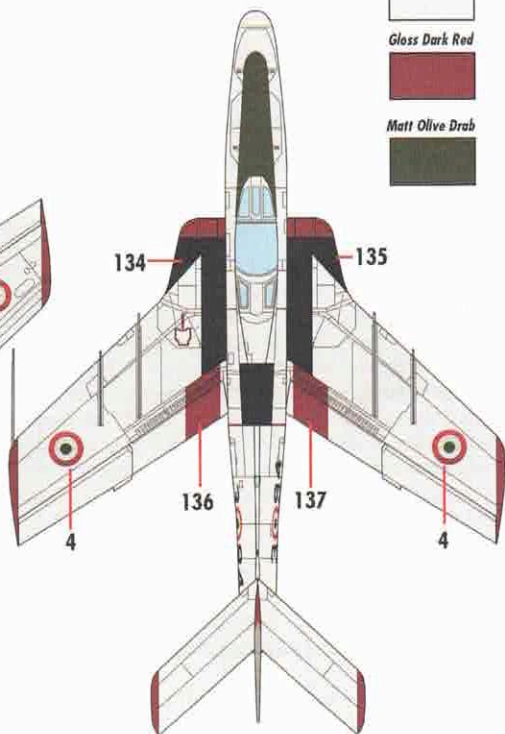
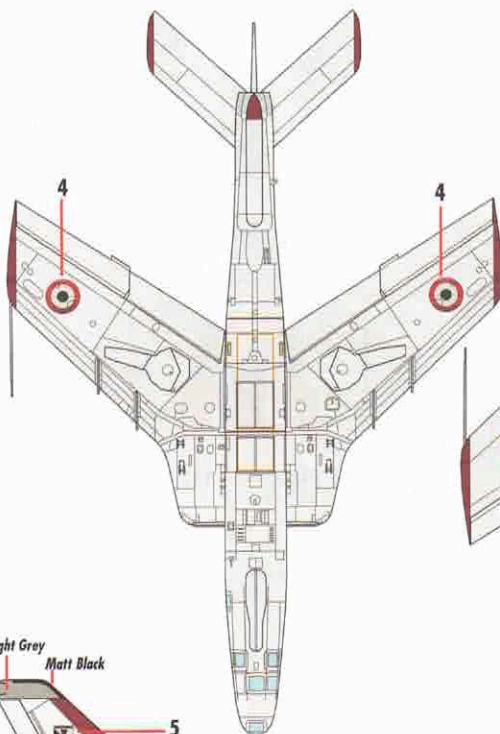

# RF-84F Thunderflash

RF-84F-25-RE Thunderflash, 66th Tactical Reconnaissance Wing, USAF, 1956

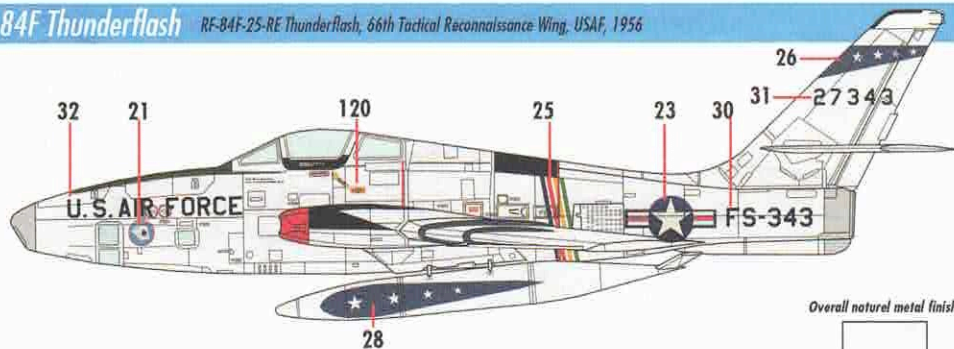

Overall natural metal finish



Grey



Matte Olive Drab

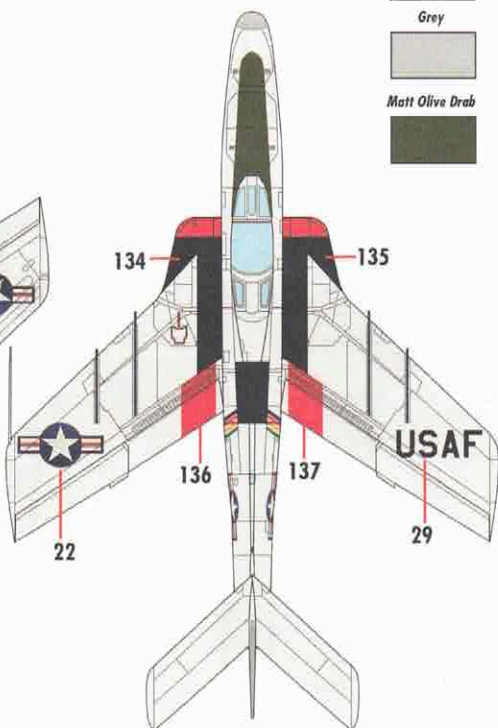
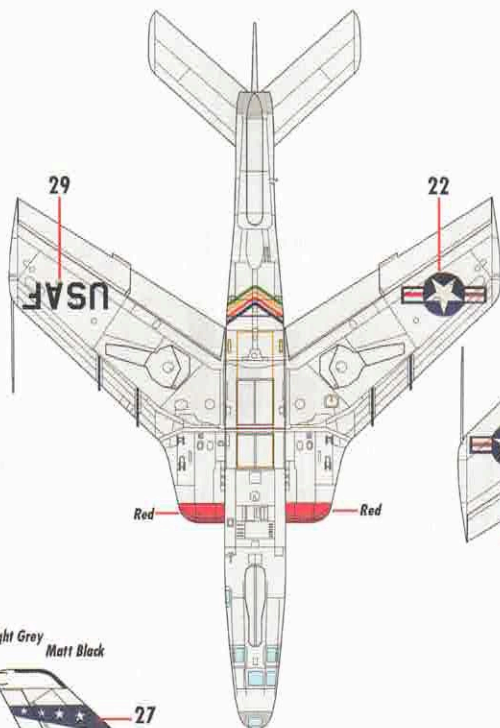

Light Grey  
Matte Black

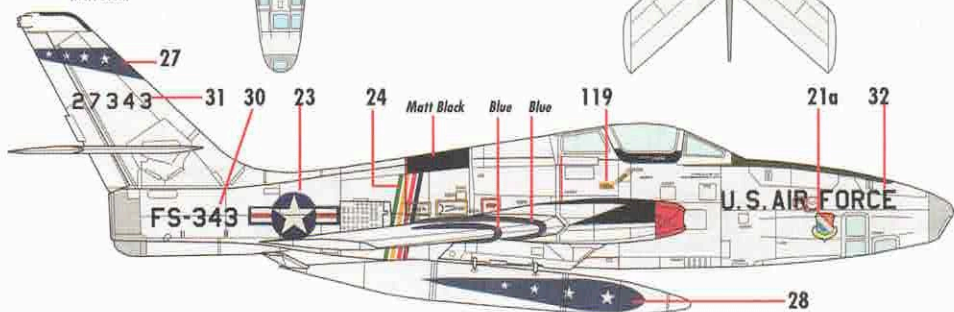

3094

3094

27394

27394



FR-28 FR-28

FR-28 FR-28



P-4 P-4

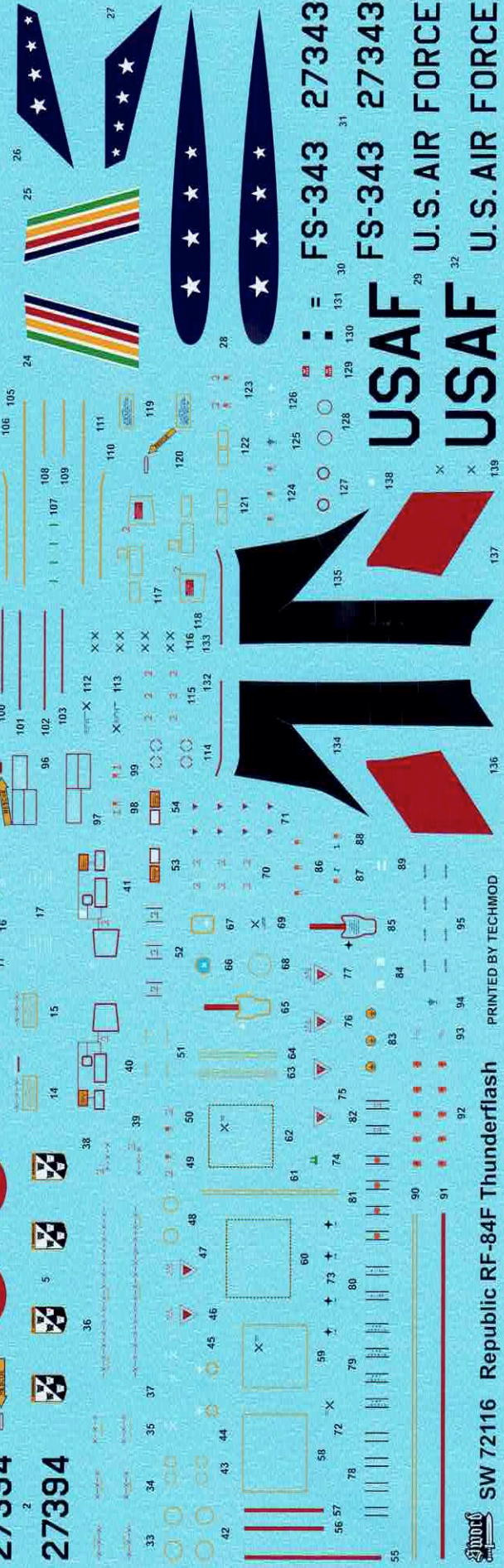
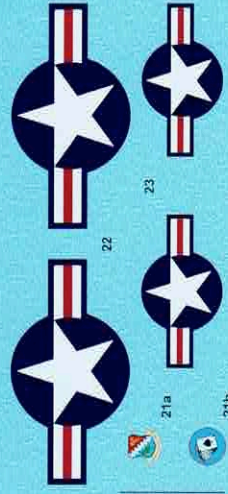

FS-343 27343

FS-343 27343

U.S. AIR FORCE

U.S. AIR FORCE

SW 72116 Republic RF-84F Thunderflash

PRINTED BY TECHMOD

