

**ACADEMY**

HOBBY MODEL KITS

13207

# U.S. MEDIUM TANK

# M4A3 SHERMAN

## 105mm HOWITZER & M1 DOZER BLADE



1/35th Scale

### M4A3 셔먼 105mm M1 도저 블레이드

The Sherman was originally intended to carry a 75mm main gun. But the turret design also incorporated features to allow a 105mm howitzer to be fitted. Soon after Sherman production started, work also began on developing a satisfactory mount for the M4 105. The M4A3 Sherman tank was used in both the European and Pacific Theaters of Operations, during World War II. It also served in the Korean War. It was designed to support the infantry, giving them additional firepower when advancing. There were few vehicles fitted with HVSS deployed to Europe, but there were some, so in that regard the kit represents a culmination in Sherman development. In the Pacific, it was also used with a bulldozer blade mounted on the front to cut a path through the thick jungle. The bulldozer blade was a valuable, new battlefield tool. A 1943 field modification added the hydraulic dozer blade from a Caterpillar D8 bulldozer to an M4 Sherman. The later M1 dozer blade was standardized to fit any Sherman with VVSS suspension.

Der M4 Sherman war der erste vollwertige mittlere Panzer der amerikanischen Streitkräfte im zweiten Weltkrieg. Er kam an fast allen Fronten zu Einsatz. Gemäß der US Panzer-Doktrin war er zur Unterstützung der Infanterie gedacht. Das Ford GAA V-8 Triebwerk verlieh der A3 Version ihre Bezeichnung. Sie war die einzige Variante, welche nach dem Ende des Krieges noch offiziell weiter genutzt wurde. Dabei verwendete man das breitere HVSS Fahrwerk des M4A3E8. Bereits während des Krieges baute man Feldmodifikationen des Räumschildes des D8 Caterpillar an Sherman Panzer. Diese wurden schließlich als M1 DOZER standardisiert und waren zusammen mit der 105mm Haubitze eine gern eingesetzte Kombination, welche noch im Korea Konflikt 1950-53 ins Feld geführt wurden.

M4A3셔먼戰車は第二次世界大戦でヨーロッパ・太平洋戦線の作戦および朝鮮戦争で使用されました。M4A3셔먼戰車は歩兵の火力支援を目的として設計されました。太平洋戦線では、厚いジャングルで小道を切り開くためにブルドーザーブレードが前面に取り付けられ使用されました。ブルドーザーブレードは効果的な新しい戦場ツールでした。1943年の戦地での改造では、水圧式のドーザーブレードが装軌式D8ブルドーザーやM4셔먼などに追加されました。後にM1ドーザーブレードはどのような셔먼戰車にも取り付けられるようにVVSSサスペンションと共に標準化されました。

2차 대전 개전 이래 셔먼은 미군과 연합군의 주력전차로, 생산된 수량도 엄청나지만 그에 못지않게 많은 형식의 차량이 존재했다. 그중 원래 셔먼의 주 무장 이었던 75mm 포 대신 105mm 곡사포를 탑재한 화력지원용의 셔먼도 개발 되었다. 105mm포 탑재 셔먼은 주로 M4 차체와 M4A3 차체를 이용했는데, M4차체를 이용한 셔먼이 1,600대 정도 생산된 것에 비하면 3,000대 가까이 생산된 M4A3 차체를 이용한 셔먼이 105mm포 탑재 셔먼의 대다수를 차지했다. 특히 M4A3 105mm 셔먼은 구형의 VVSS 현가장치를 이용한 셔먼 보다는 신형의 HVSS현가장치를 사용한 셔먼이 주로 생산되었으며, 3,000대의 총생산량 중 그 수는 2,539대에 달했다. 105mm 포 탑재 셔먼은 2차 대전 당시의 유럽전선과 남태평양전선에서 활약 했으며, 한국전쟁에서도 많은 수의 M4A3 105mm 셔먼이 사용되었다. 특히 전쟁후반으로 갈수록 전차와의 교전 보다는 화력지원의 필요성이 높았던 한국전쟁에서의 105mm포 탑재 셔먼은 그 활용도가 매우 높았다. 한국전쟁에서 사용되었던 대다수의 M4A3 105mm 셔먼은 전방에 M1 도저 블레이드를 장착했으며, 전투 시 화력지원과 후방지원 이라는 목적에 걸맞게 탁월한 성능을 발휘했다.

**<READ THIS BEFORE YOU BEGIN>**

- Study the instructions before assembling.
- Do not use too much cement to join parts.
- Open a window or make area well ventilated when cement or paint is in use.
- Check the fit of each piece before cementing into place.
- Never use cement or paint near open flame.
- Tear up and throw away the empty plastic bags to avoid danger of suffocation for little children.

**<ALLGEMEINE HINWEISE>**

- Die Anordnung der Bauteile ist aus den Zeichnungen der Anleitung ersichtlich.
- Die Teile vor dem Verkleben ungeleimt zusammenhalten, um ihren paßsitz zu prüfen.
- Klebstoff nicht zu dick auftragen.
- Klebstoff und Farben niemals in der Nähe einer Flamme verwenden.
- Während der Bemalung mit Spritzpistole oder Pinsel für frische Luftzufuhr, z.B. öffnen des Fensters, sorgen.
- Bausatz von kleinen Kindern fernhalten. Verhüten Sie, daß Kinder irgendwelche Bauteile in den Mund nehmen oder Plastiktüten über den Kopf ziehen.



**<READ THIS BEFORE YOU BEGIN>**  
**<ALLGEMEINE HINWEISE>**  
**<LISEZ CE QUI SUIT AVANT DE COMMENCER LE MONTAGE>**  
**<組み立てる前に>**  
**<조립하기 전에>**

**<LISEZ CE QUI SUIT AVANT DE COMMENCER LE MONTAGE>**

- Etudier les schémas d'assemblage. - Contrôler que chaque pièce soit bien conforme avant de la coller à sa place.
- N'utilisez pas trop de colle pour réunir les pièces. - Ne jamais manipuler la colle ou peinture à proximité d'une flamme.
- Aérer soigneusement la pièce où vous peignez (ouvrir la fenêtre). - Après avoir sorti les pièces du sac en plastique, déchirer le sac afin d'éviter que les enfants ne le mettent sur la tête et ne s'étouffent.

**<組み立てる前に>**

- 組み立てる前に説明書をお読み下さい。 - 部品をランナーから切り出す時は模型用ニッパーとカッターを使用します。
- 接着剤を少なめに使うことがきれいに仕上げるコツです。 - 組み立て後の部品やビニール袋は小さな子供の手の届かない安全な所に保管して下さい。
- 接着剤や塗料を使用する時はときどき窓を開けて換気をお願いします。 - 接着する前に部品を合わせて確かめます。

**■조립하기 전에**

- 부품을 조립하기 전에 설명서를 잘 읽어본 후 조립한다.
- 점착제에 앞서 부품을 맞추어 확인한 후 조립한다.
- 부품을 지를 때에는 칼이나 니퍼로 깨끗이 잘라준다.
- 에나멜 페인트나 점착제를 사용할 때는 창문을 열어 환기를 시키고 화기를 멀리한다.
- 점착제를 사용할 곳과 사용하지 않는 곳에 주의하고 너무 많이 바르지 않도록 한다.
- 사용 후 남은 부품은 어린 아이들의 손에 닿지 않도록 잘 처리한다.

\* ( ) is opposite number. → Cement 접착합니다.

( )는 반대측 번호입니다. ----▶ Do not cement. 접착하지 않습니다.

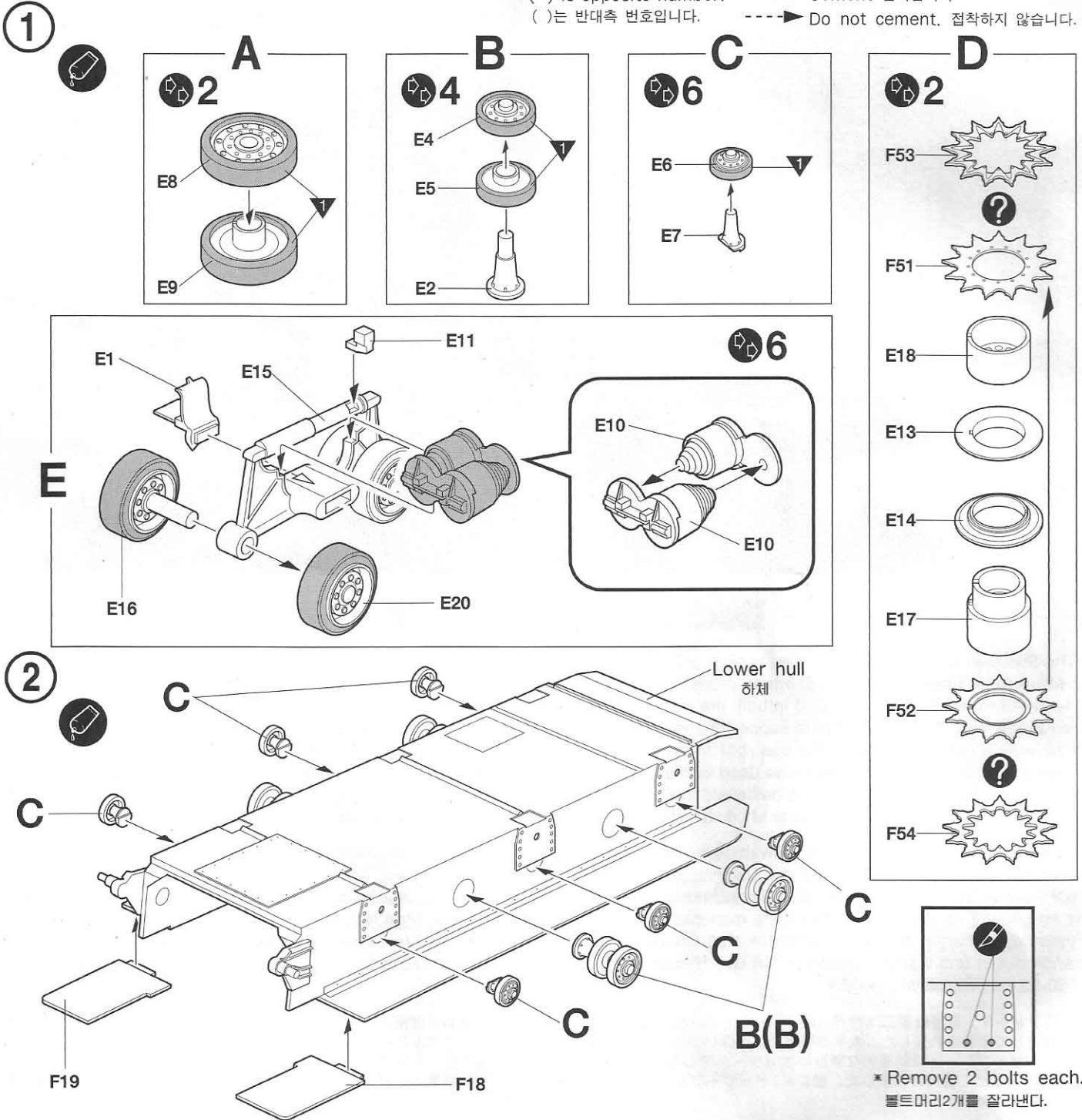

\* Remove 2 bolts each.  
 볼트머리2개를 잘라낸다.

<b>1</b> 점착한다. Cement parts Collar Kleben Pegar Incollare Colar Kleben	<b>2</b> 점착하지 않는다. Do not cement Ne pas coller Nicht kleben No pegar Non incollare Nao colar Niet kleven	<b>3</b> 순대림 조립한다. Repeat operation Répéter l'opération Vorgang wiederholen Repitir la operacion Repitire Repitir a operacion Herhalen	<b>4</b> 전사지를 붙인다. Decals Décalcomanies Abziehbild	<b>5</b> 무게추를 넣는다. Add weight Lustar Gewicht	<b>6</b> 구멍이나 홈을 맞춰준다. Use filler Mastiquer Schielen
<b>7</b> 잘라낸다. Cut away Couper Schneiden Cortar Tagliare Cortar Snijden	<b>8</b> 선택한다. Optional parts Choix Auswahlmöglichkeit Eleccion Scelta Opcao Keuze	<b>9</b> 반대측도 조립한다. Repeat for opposite side Répétition de la page Wiederholung für gegenüberliegende Seite	<b>10</b> 구멍을 뚫어준다. Make hole Faire un trou Öffnen	<b>11</b> 주의한다. Be careful Faire attention Hier Vorsicht	<b>12</b> 색칠 및 전사지 붙이기 번호 Painting scheme number Numeros de la liste de peintures Lackierschemanummer

3

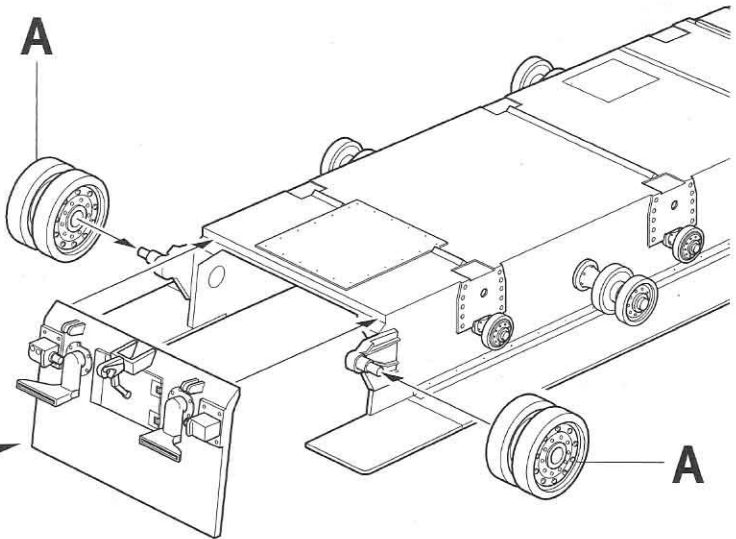
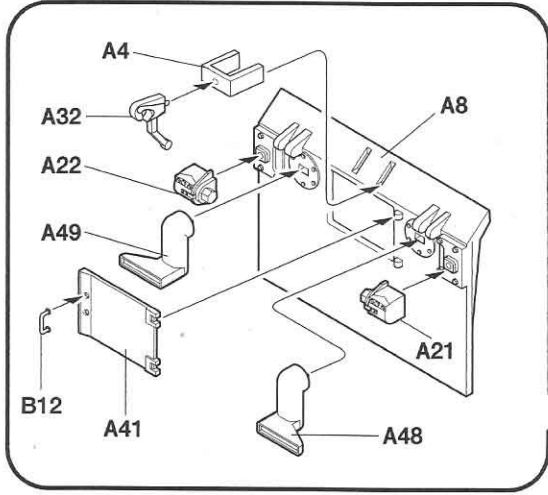

4

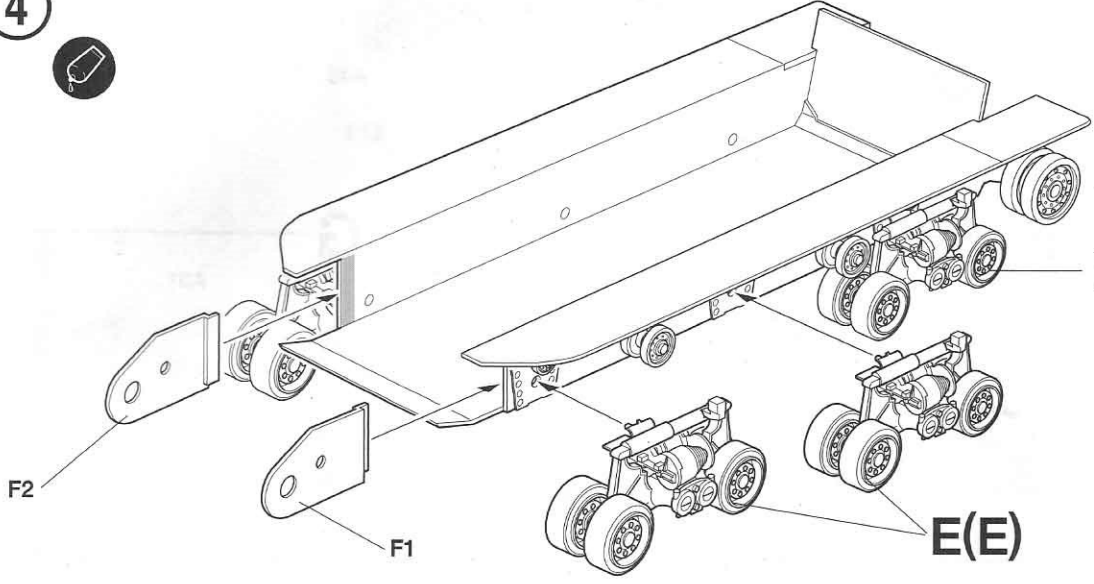

5

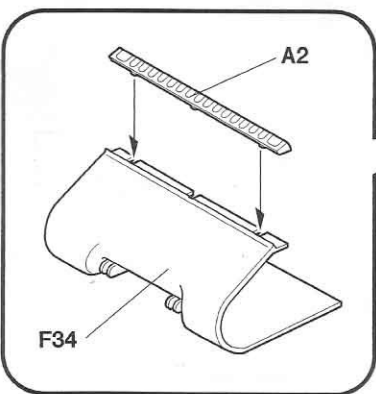
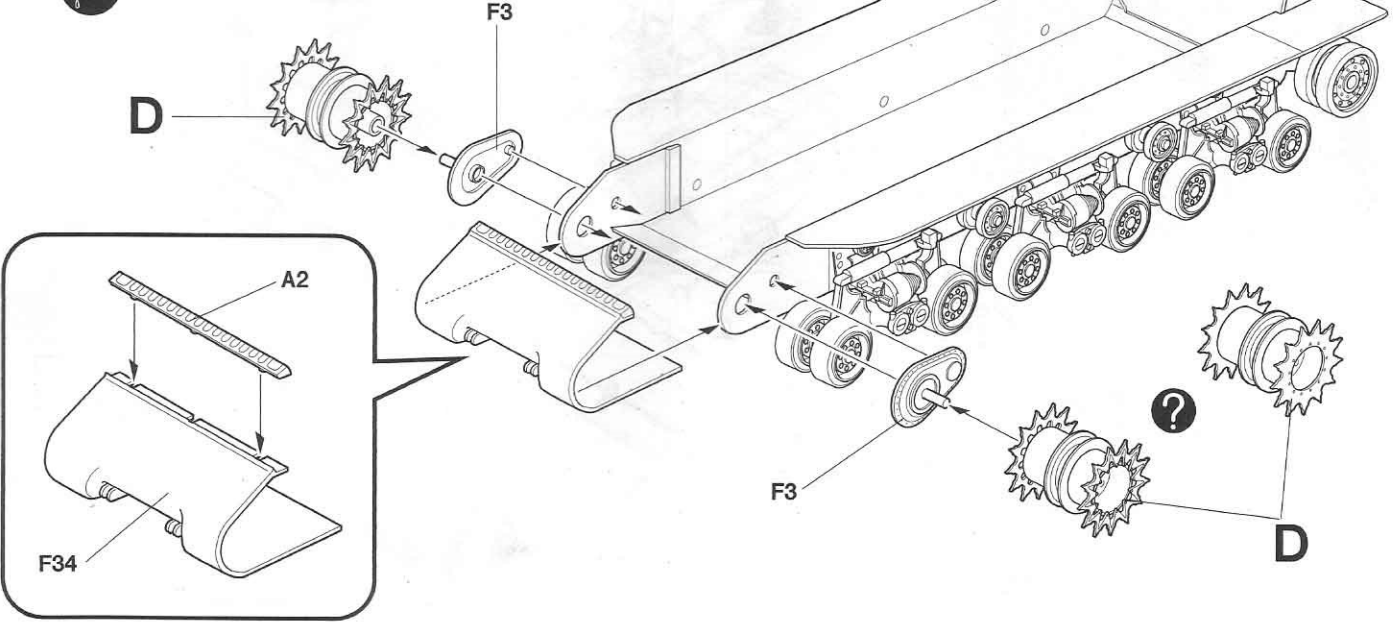

6

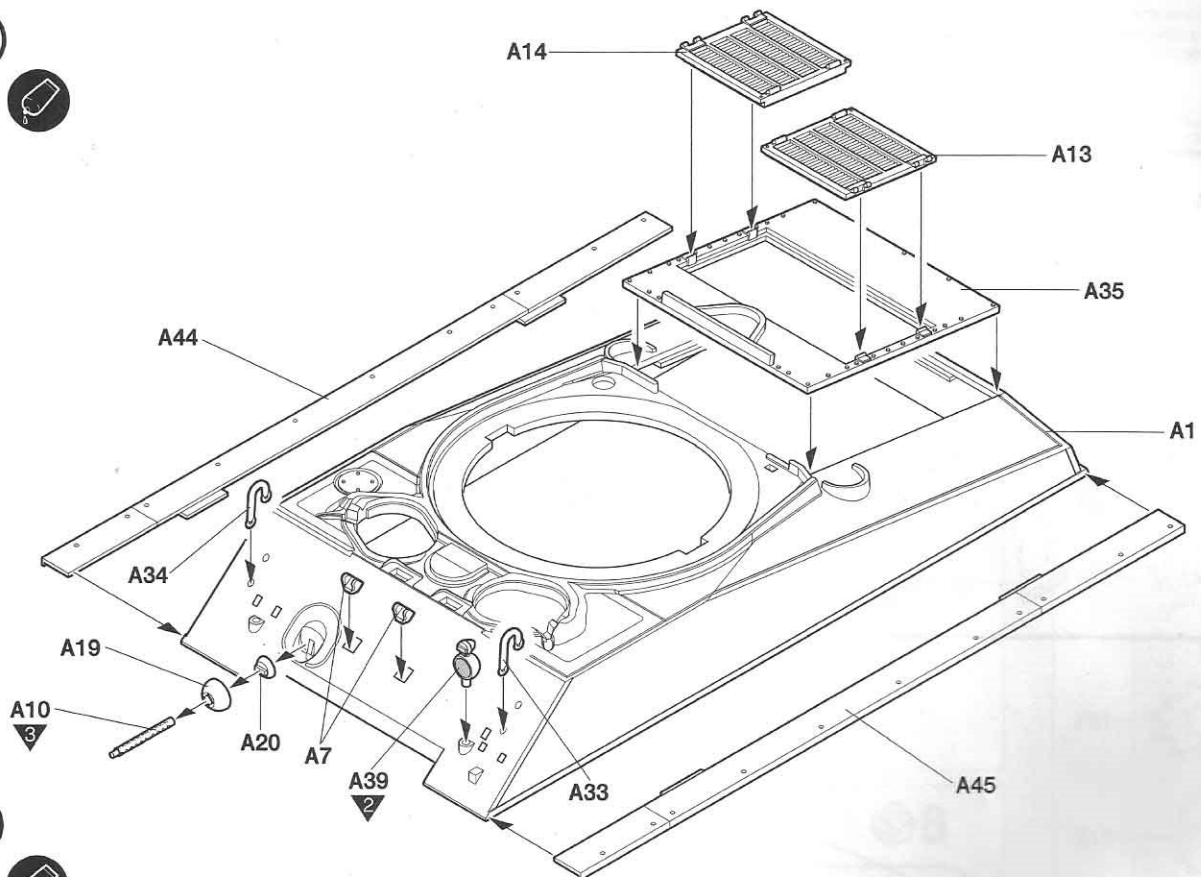

7



F

G

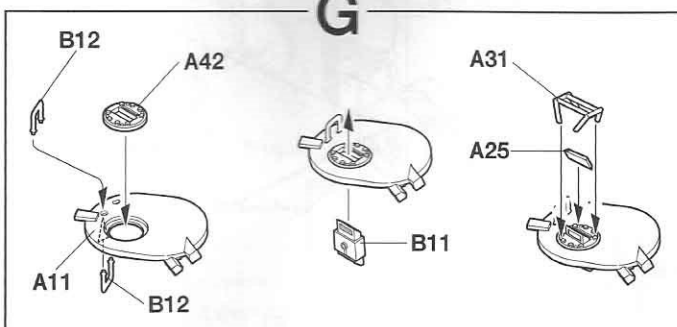
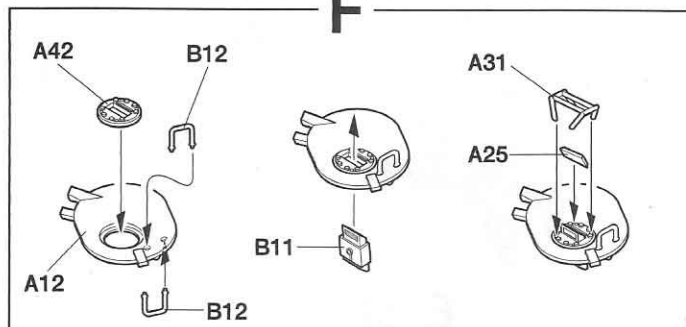

F

G

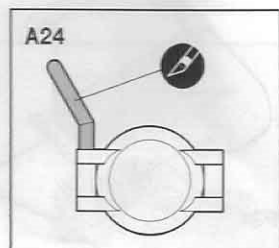
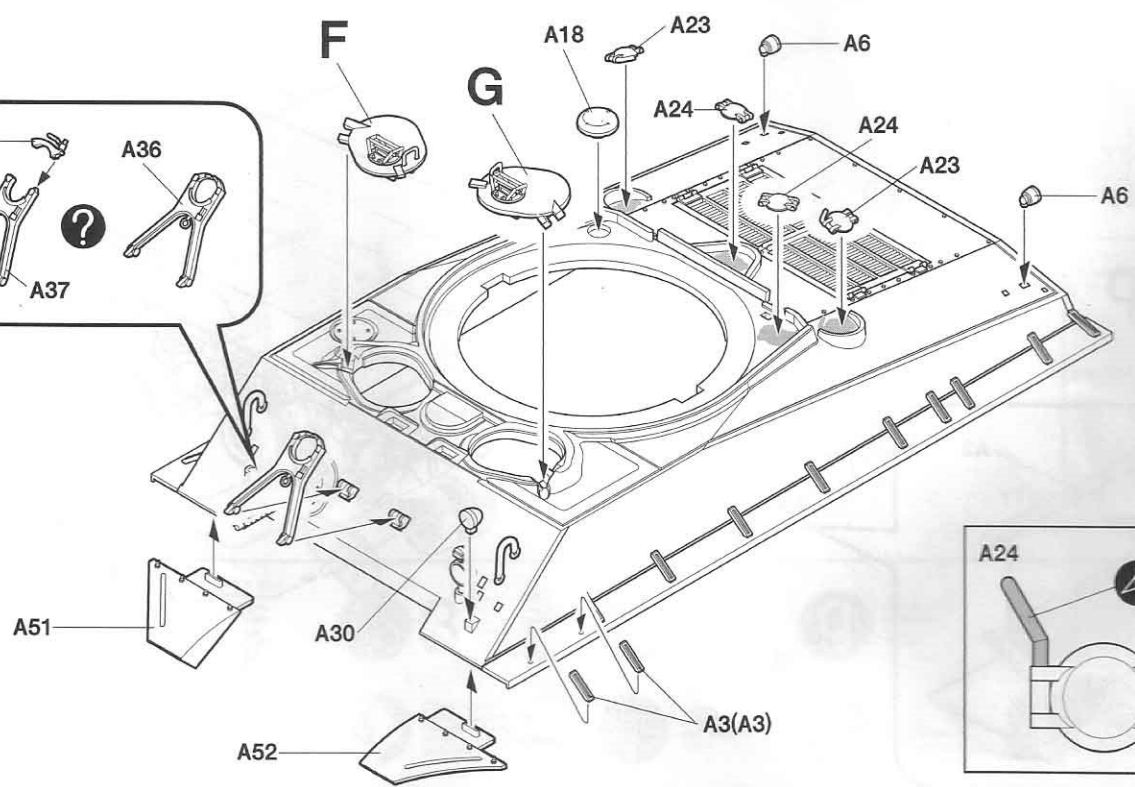
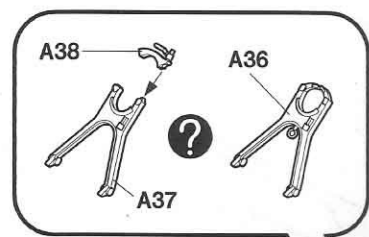

8

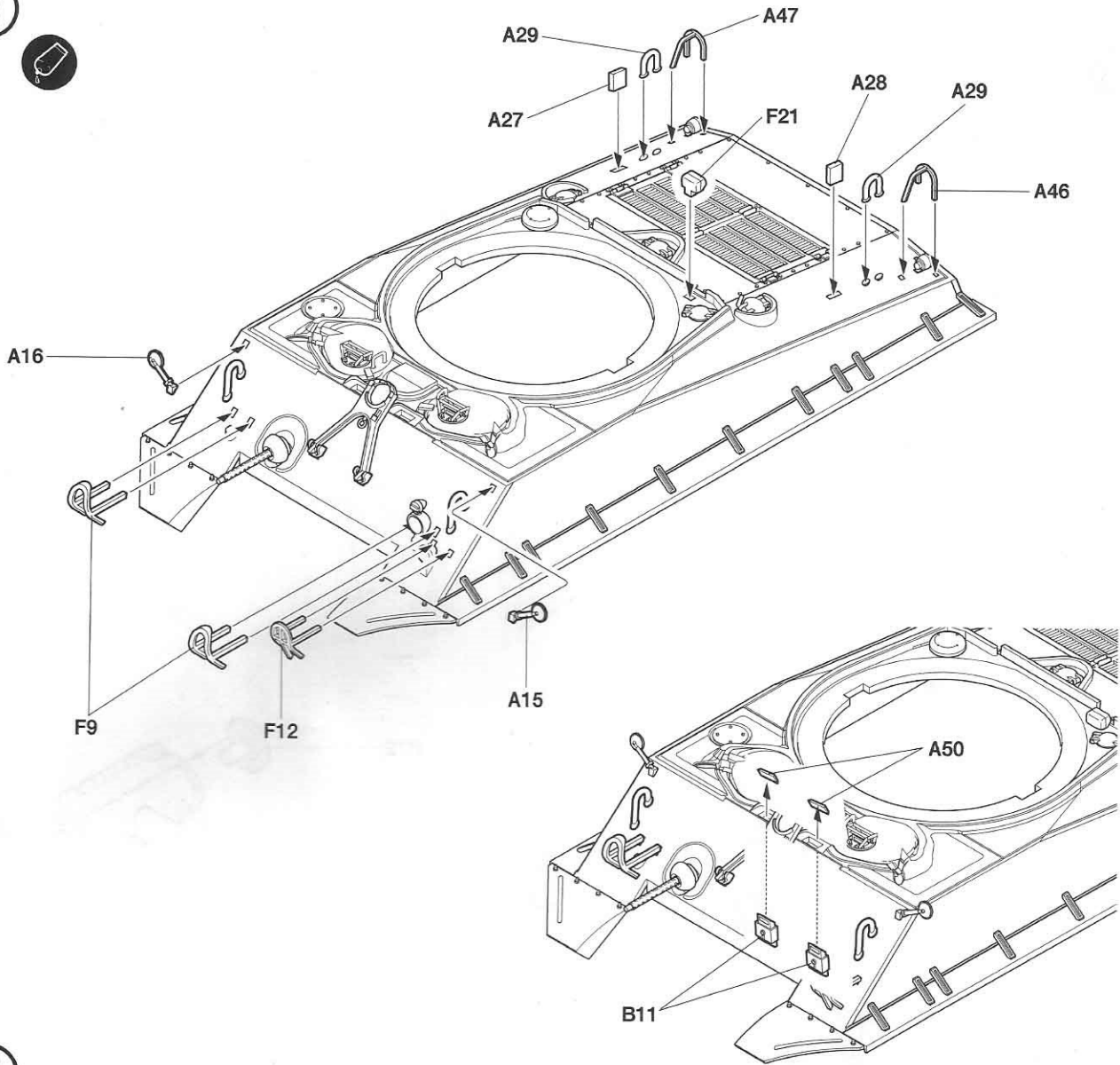

9

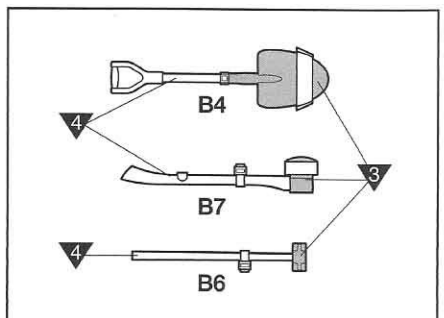
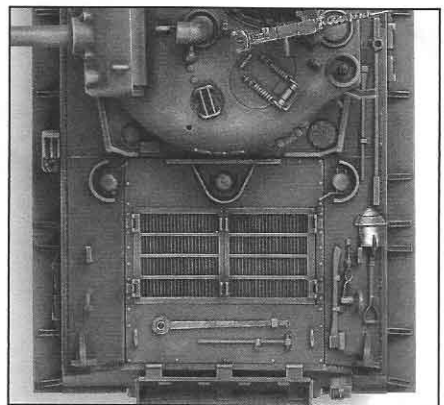
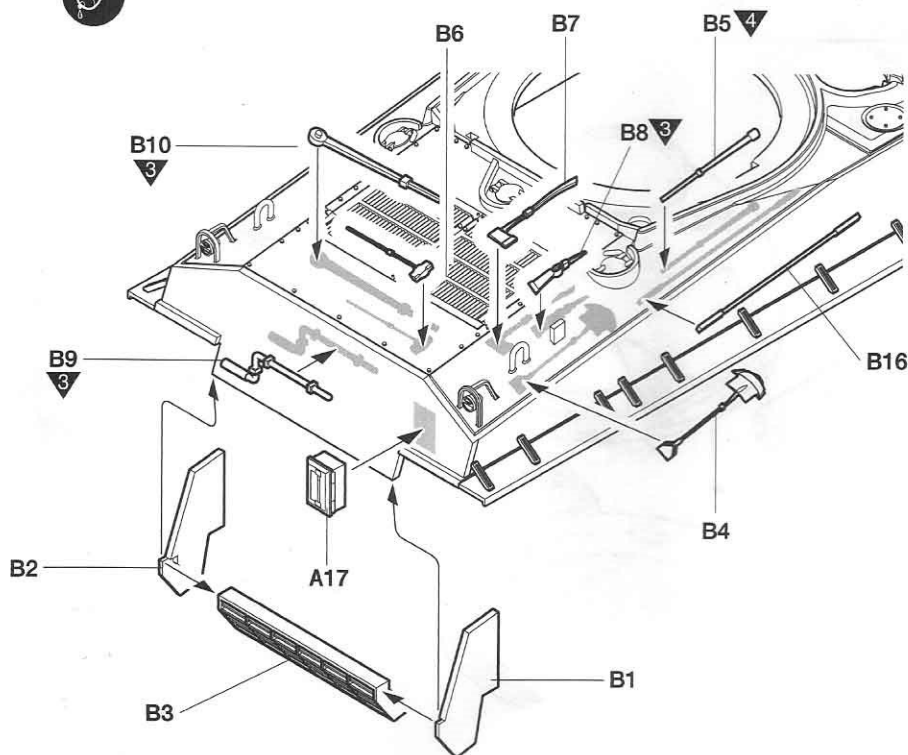

10

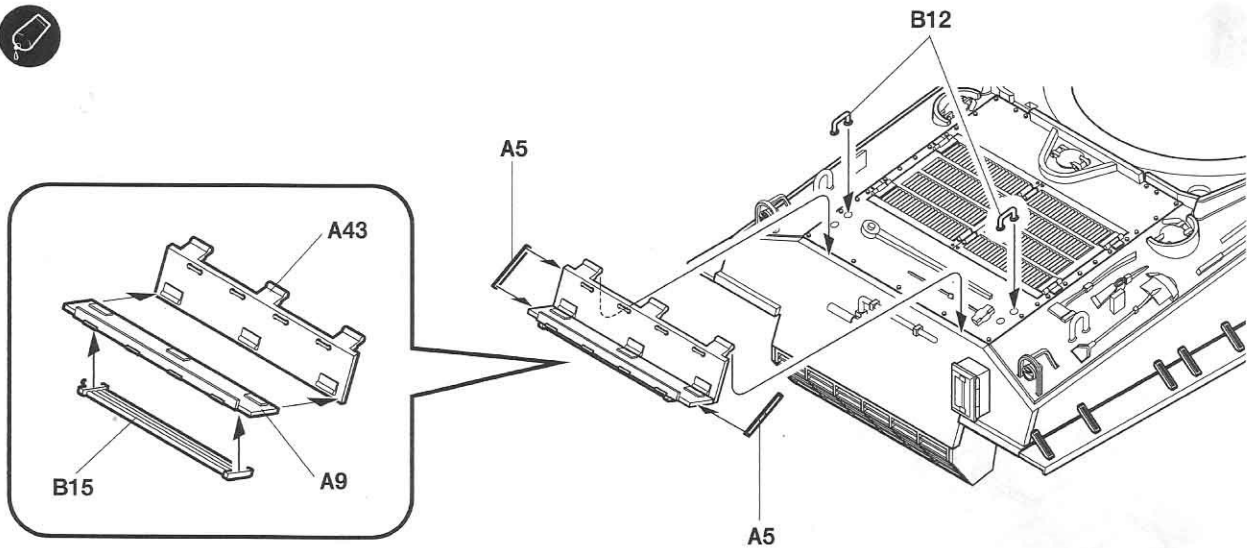

11

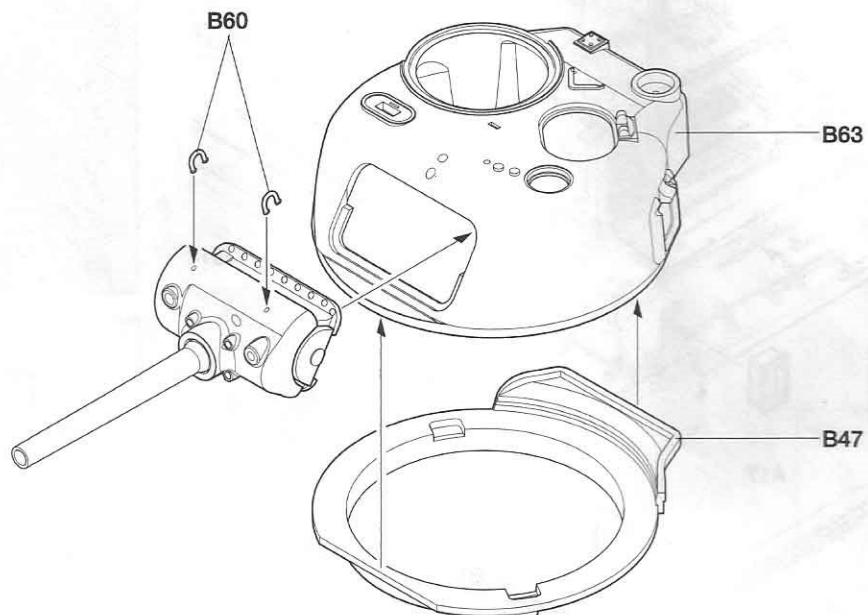
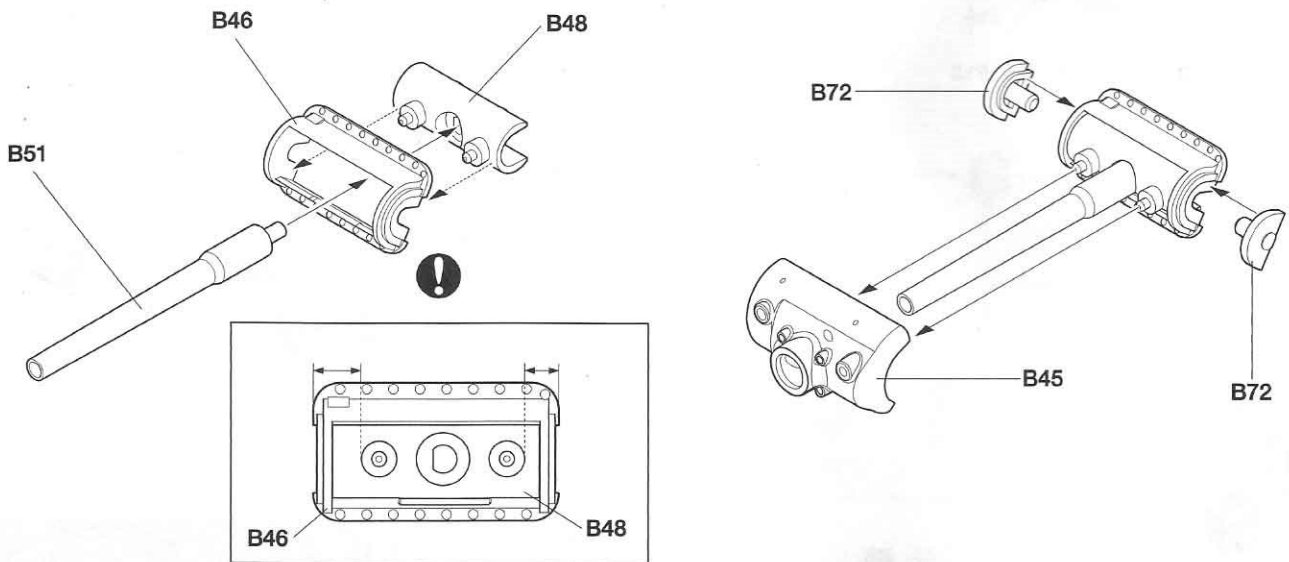

12

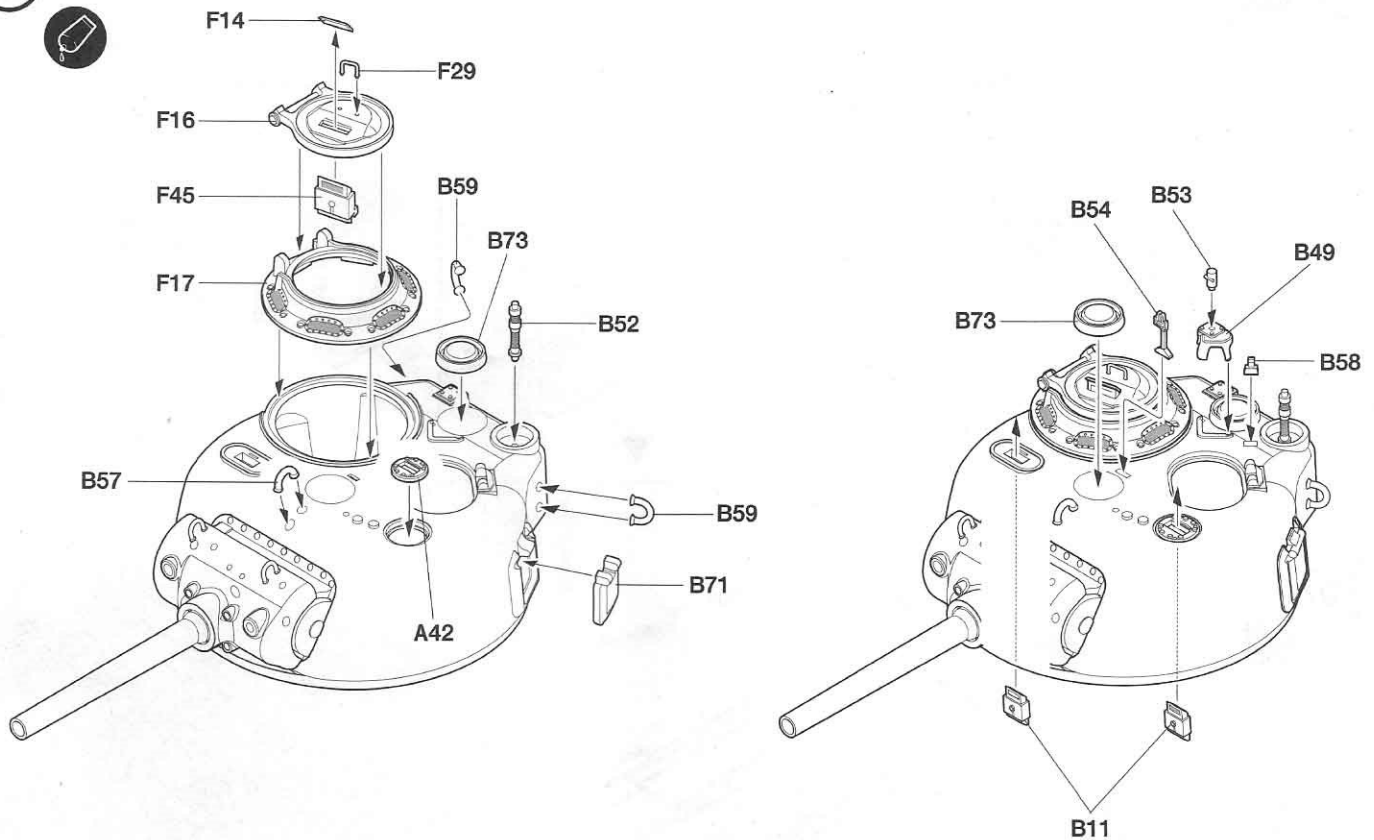

13

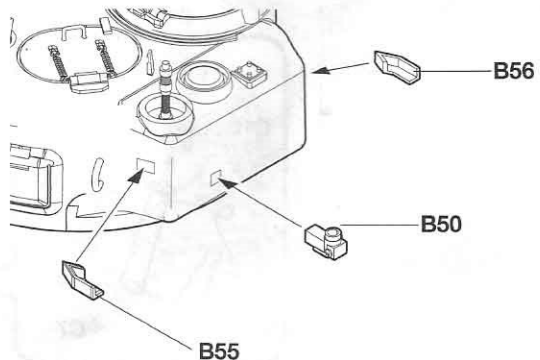
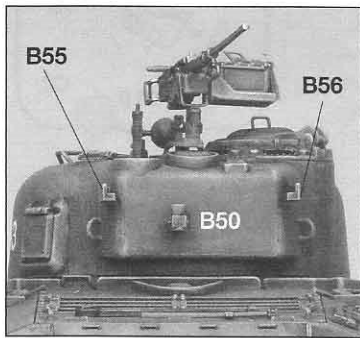
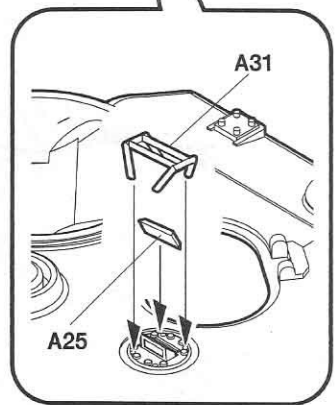
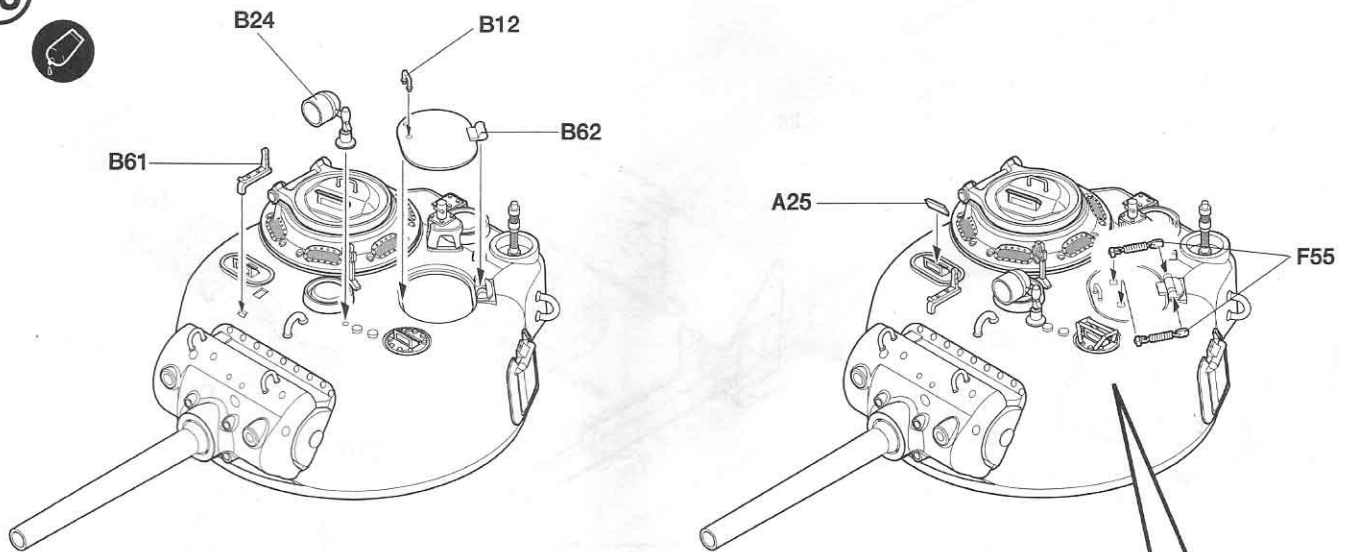

14

H

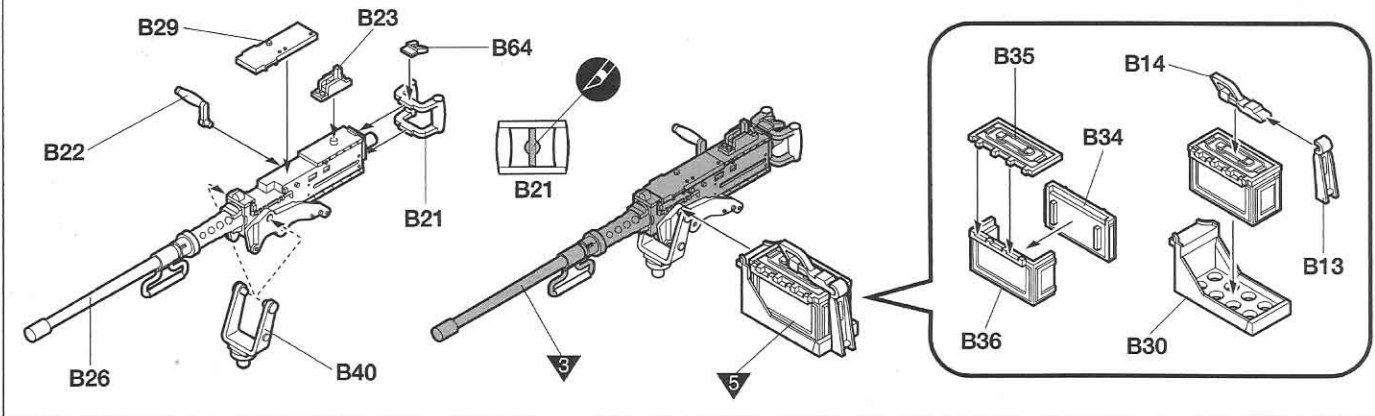

15

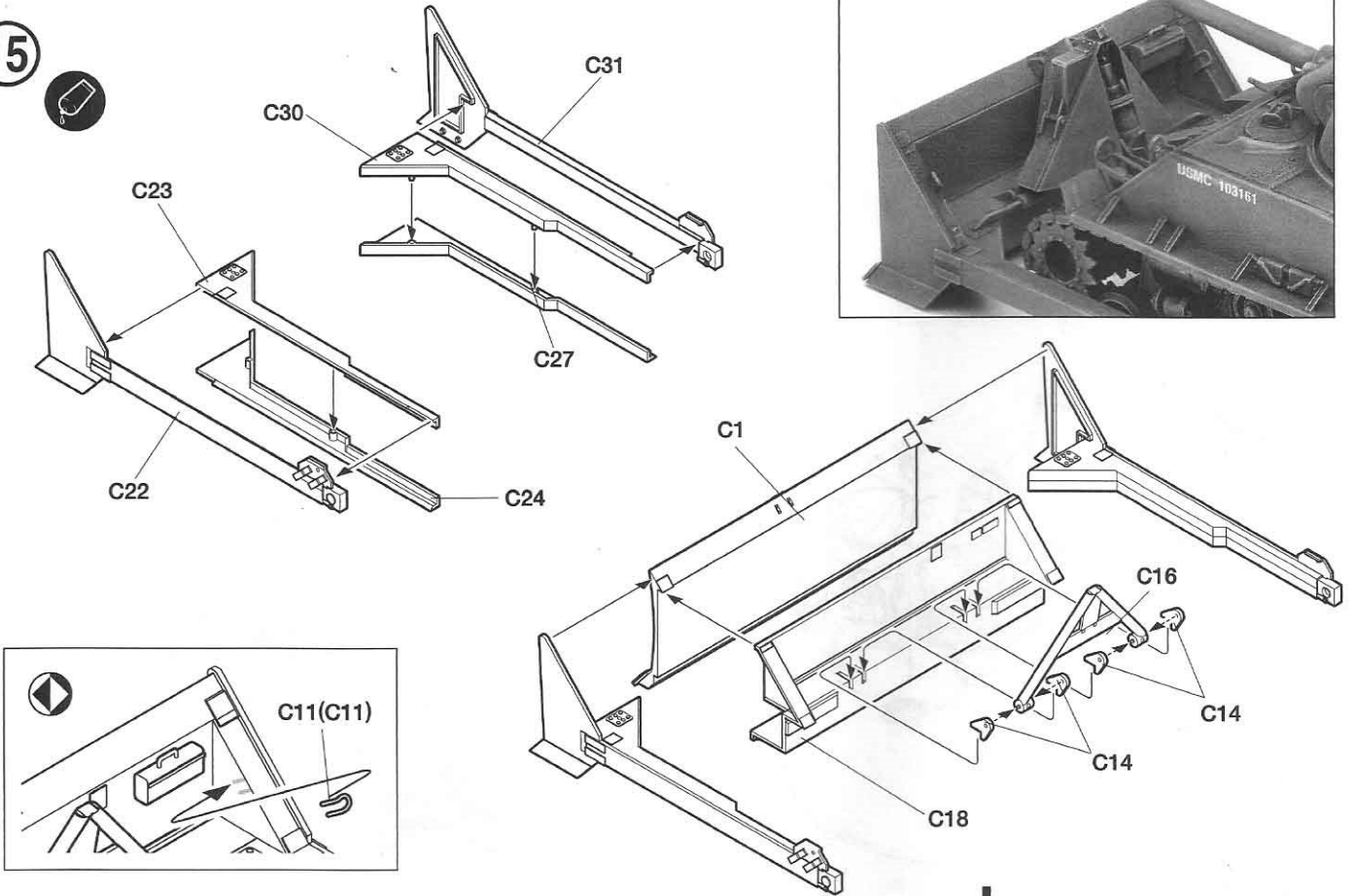
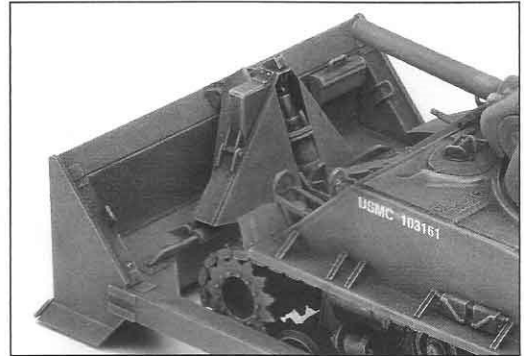



16



H

<Tracks 캐터필러>

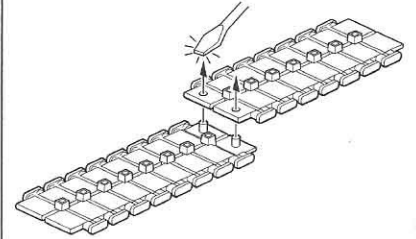

\* Melt pins together with a heated screw driver.  
불에 달군 드라이버 등으로 핀을 녹여 고정시켜 연결한다.

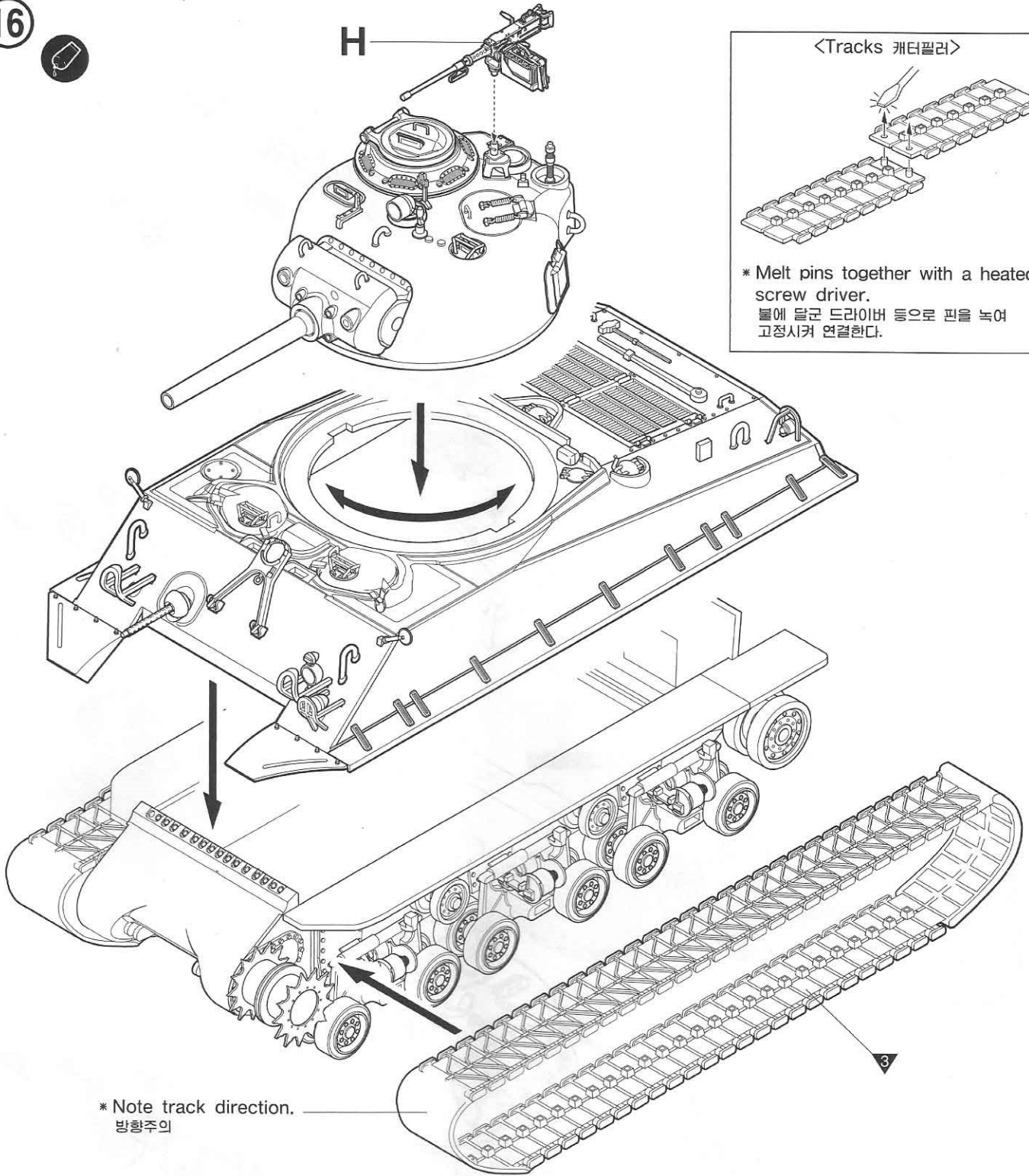

\* Note track direction.  
방향주의

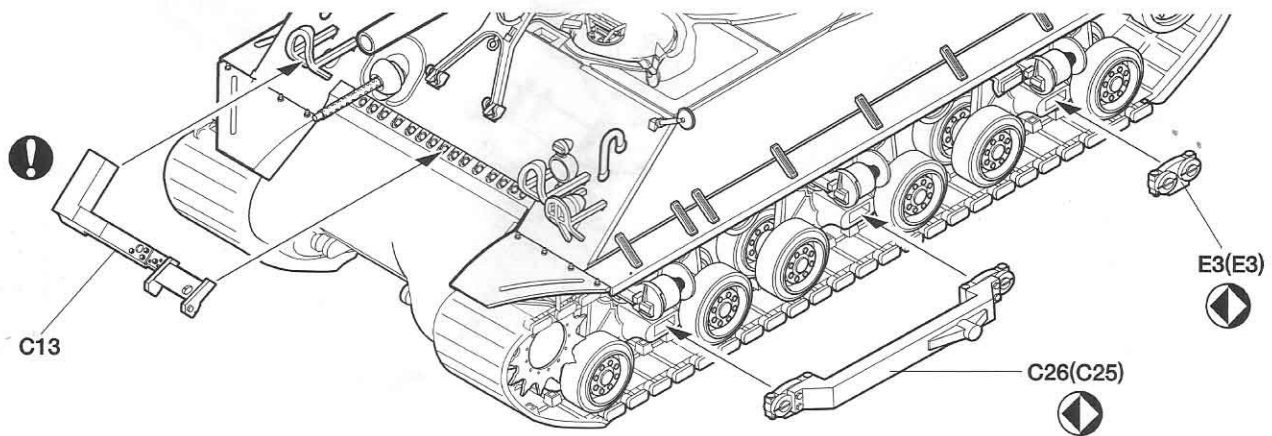

17



C15

B17

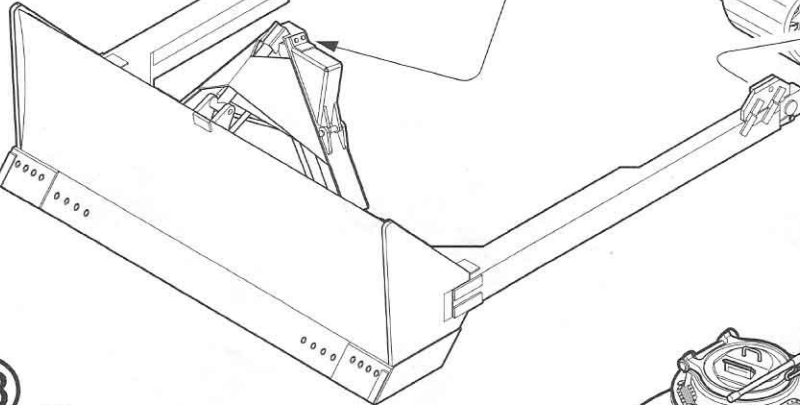
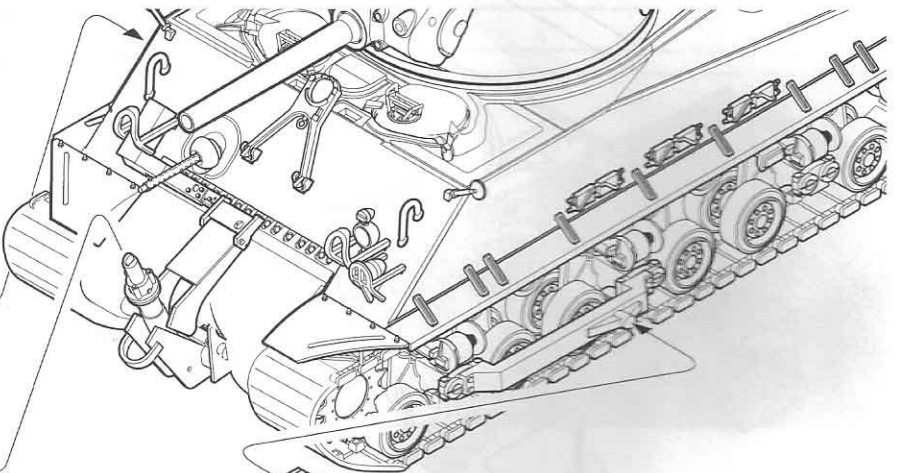
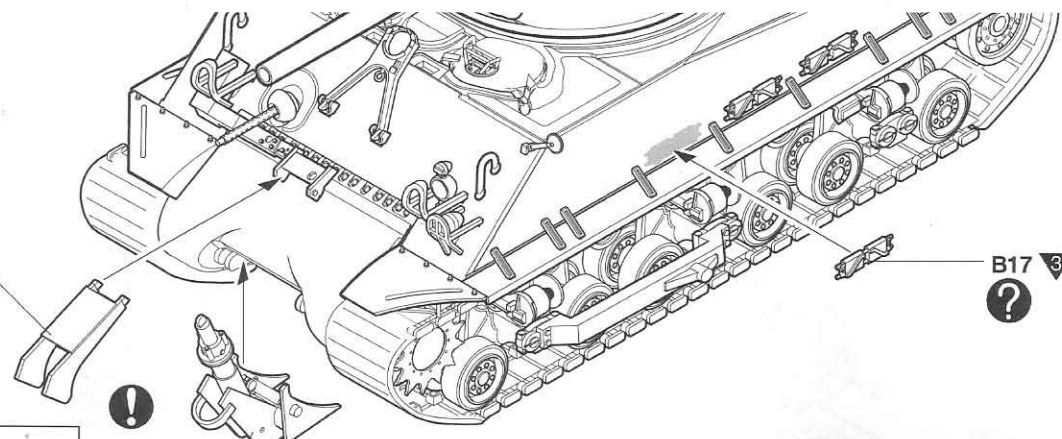
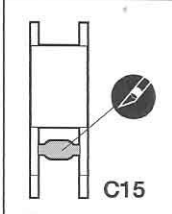

18

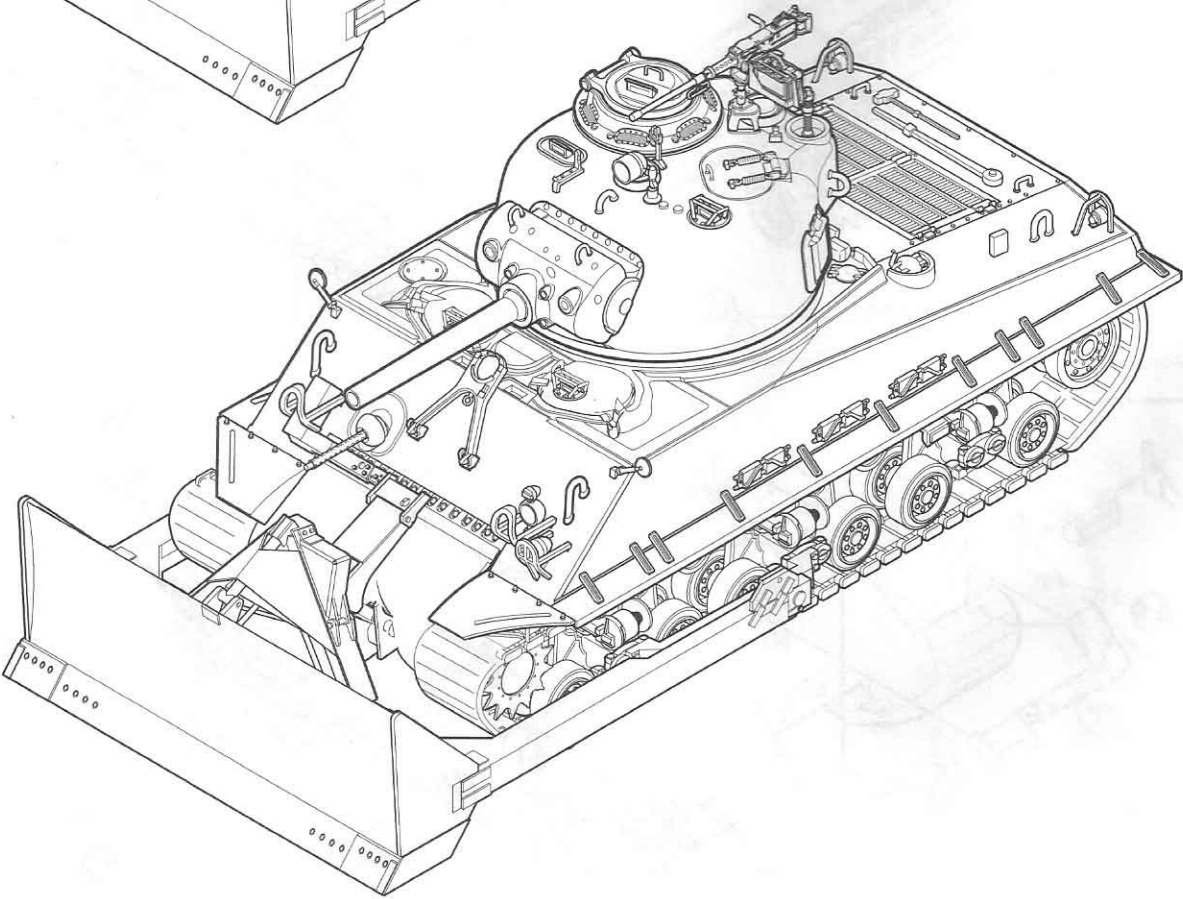

<Accessories 액세서리>

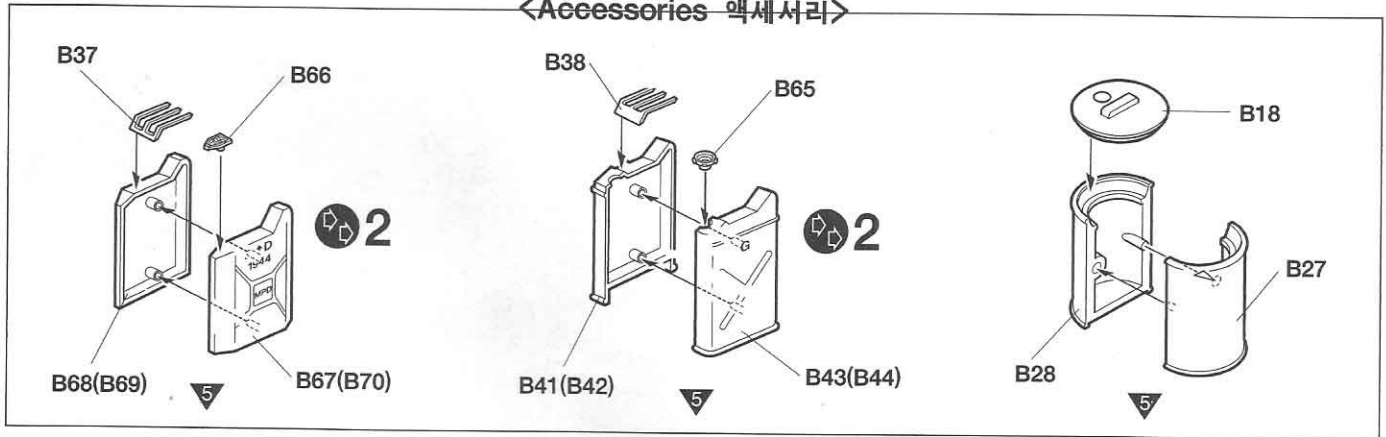

**Painting & Decal placement** 색칠 및 전사지 붙이기



**1** Hamhung Korea, November 1950.  
1950년 11월 한국, 함흥

Body Color :   
차체색

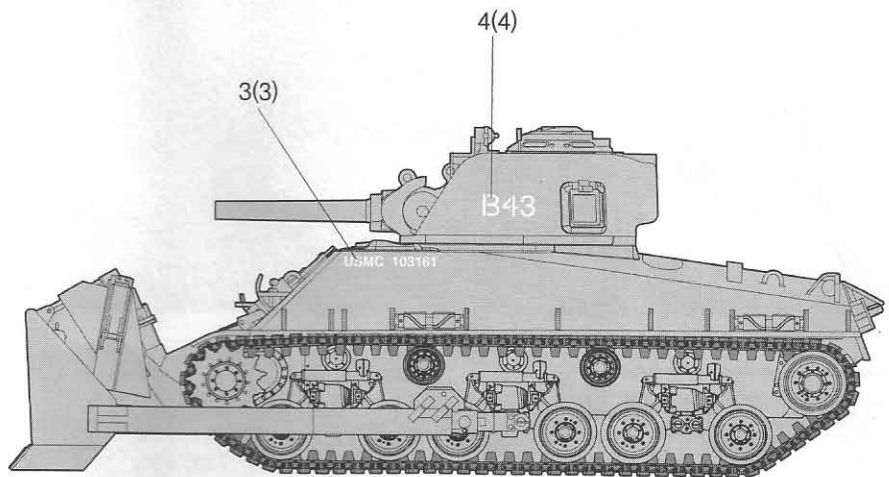
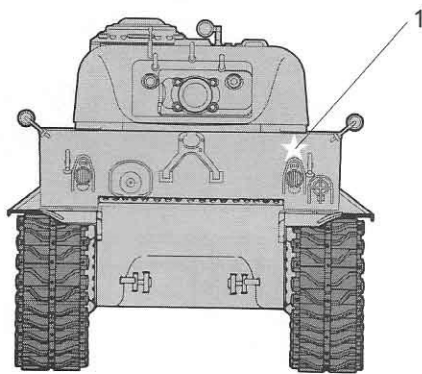

**2** Hamhung Korea, November 1950.  
1950년 11월 한국, 함흥

Body Color :   
차체색

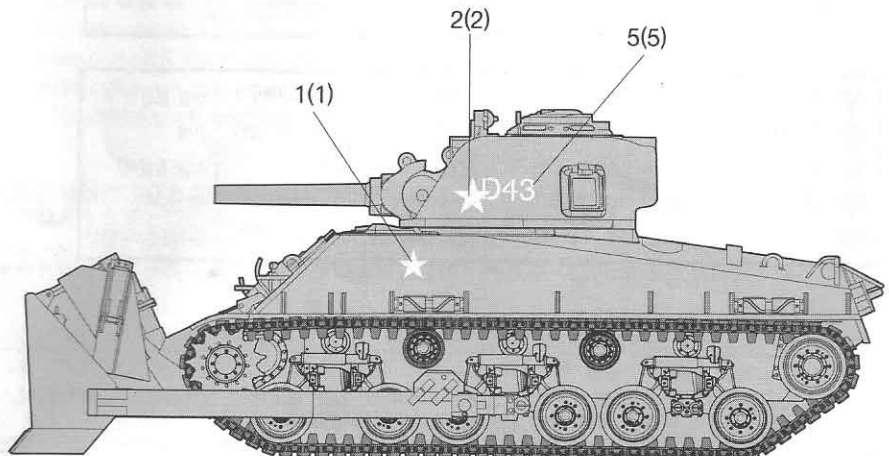
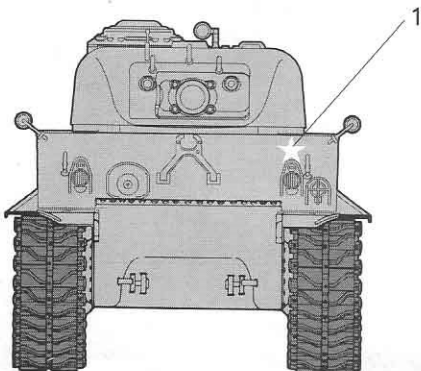

# Parts Locating Diagram 부품도

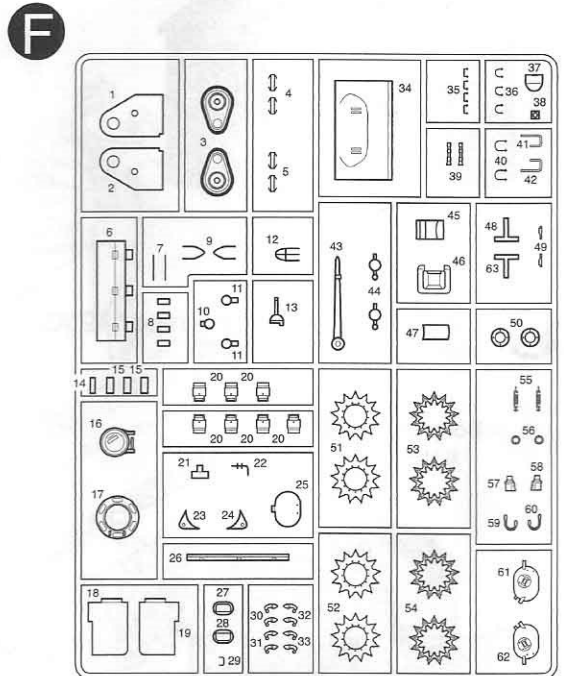
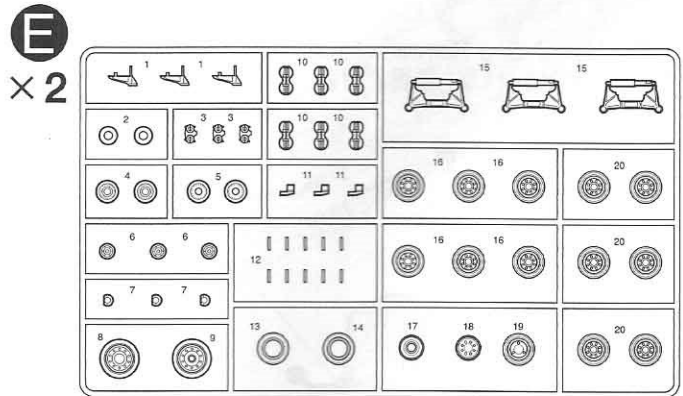
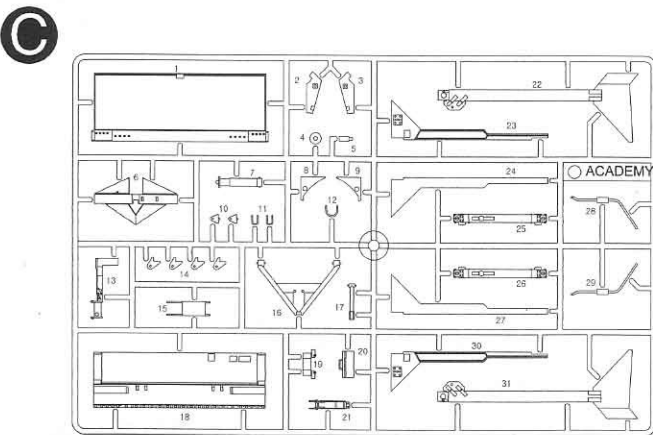
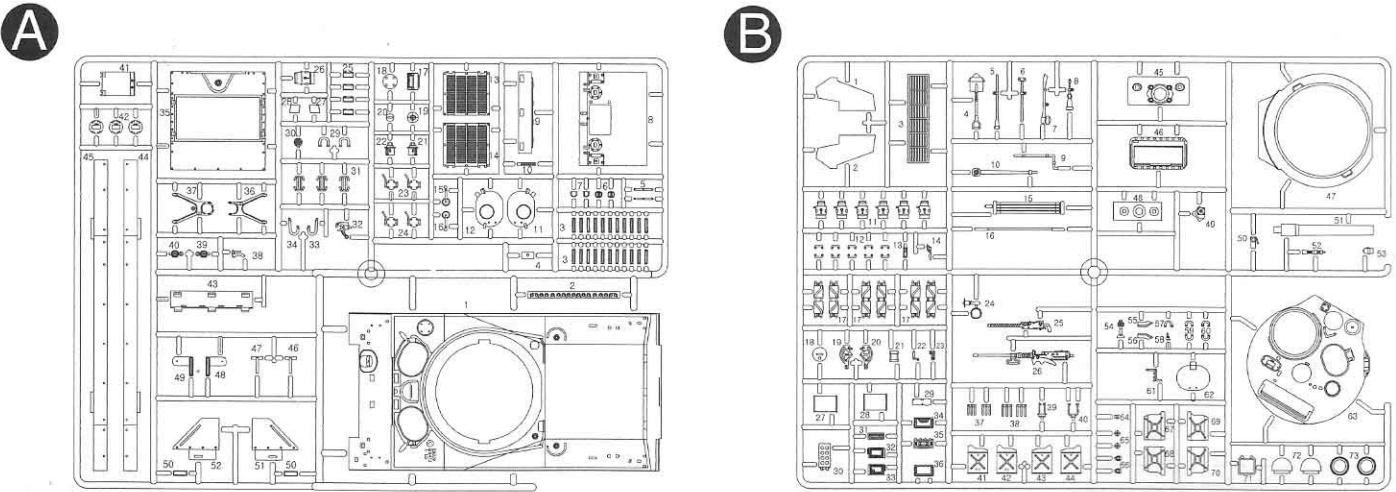
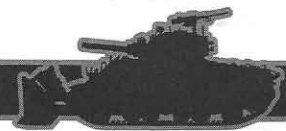

**■ Unused Parts 불필요부품**  
 A40, A26, B12×2, B19, B20, B25, B31, B32, B33, B39, E3×4, E12, F4, F5, F6, F7, F8, F10, F11, F13, F15, F20, F22, F23, F24, F25, F26, F27, F28, F30, F31, F32, F33, F35, F36, F37, F38, F39, F40, F41, F42, F43, F44, F46, F47, F48, F49, F50, F56, F57, F58, F59, F60, F61, F62, F63

**■ Lower Hull 하체 × 1**  
**■ Flexible Track 연결 트랙 × 2**  
**■ Decal 전사지 × 1**

H1 in painting indication is the number of GSI Creos Aqueous Hobby Color, while ■ is that of Mr. Color.  
 塗料指定のH1はGSIのレオス・Mr.カラー、H1は水性ホビーカラーの番号です。  
 H1 bei Bemalungshinweisen ist die Nummer der Aqueous-Hobby-Color von GSI Creos, während ■ den Ton der Farbserie Mr. Color anzeigt.  
 Sur le guide de peinture, H1 correspond au numéro de couleur GSI Creos AQUEOUS HOBBY COLOR, alors que ■ correspond à Mr. COLOR.  
 도료지정 H1은 GSI크레오스 Mr. 컬러, H1은 수성아미비아의 번호입니다.

1	33 H12	FLAT BLACK	MATTSCHWARZ	NOIR MAT	つや消しブラック	무광 검정색
2	8 H8	SILVER	SILBER	ARGENT	シルバ (銀)	은색
3	23 H10	STEEL	STAHL	ACIER	黒鉄色	스틸(흑철색)
4	43 H37	WOOD BROWN	HOLZBRAUN	BRUN BOIS	ウッドブラウン	우드브라운
5	33 H78	OLIVE DRAB(2)	OLIV GRÜN(2)	VERT OLIVE(2)	オリーブドラブ(2)	올리브드랍(국방색)

**■ 직매점 겸 A/S센터**  
**■ A / S 센터**  
**■ 총판점 겸 A/S센터**

삼선교: 742-9293, 양재동: 575-9997, 용산: 796-1214, 아셈하비센터: 6002-6293  
 본사: 908-7000(교환147), 동대문: 745-9293,  
 서울아카데미: 907-0940, 양천아카데미: 2691-7108, 강남아카데미: 485-6884, 강북아카데미: 762-0980,  
 경기아카데미: (031)388-9815, 서면아카데미: (051)816-9773, 대구아카데미: (053)744-9293

**■ 홈페이지**  
**■ 고객 상담 문의**

<http://www.academy.co.kr>  
 080-969-7000



**ACADEMY PLASTIC MODEL CO., LTD.**  
 273-64, Suyu-dong, Kangbuk-gu, Seoul, Korea  
 TEL:82-2-908-7000 FAX:82-2-997-3003