

AIRFIX ^{1/72} Constant Scale Kit by Craft Master[®]

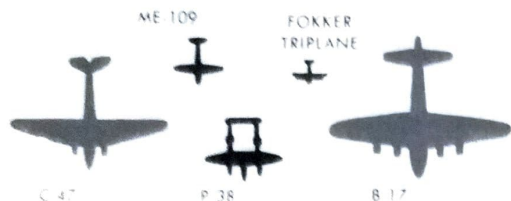

All Airfix 72 planes are made in 1/72 scale (1" = 6'0"). For example, the ME 109 has a wingspan of 5 1/2" while the B-17's is 17 1/2". Your entire collection will have the same relationship, ideal for collectors and enthusiasts. You can build over fifty constant scale combat planes in this series.

FOCKE-WULF FW 190 D

The first versions of the FW 190 went into action in 1941, and were immediately successful. The design was in advance of any other German fighter, and its success against the allied fighters of the time influenced later British fighter design.

Late in 1943 the first FW 190 D's were reported in action. These differed from earlier models in having a more powerful engine, giving a longer nose than before, and greatly improved performance.

Many variants of the FW 190 D were produced, mainly fighter versions, but ground attack aircraft were also introduced, and like the greater part of German fighters they were also adapted to serve as fighter-bombers. By the end of the war over 20,000 FW 190's had been produced.

The FW 190 D was powered by a Junkers Jumo 213 engine of 1,776 h.p. (increased to 2,240 h.p. by using methanol-water injection); top speed was 440 m.p.h. It was armed with two 7.92 mm. machine guns in the cowling and four 20 mm. cannon. Fighter-bomber variants carried one 550 lb. bomb.

COLOR SCHEME

- Pale Blue** All undersurfaces and fuselage sides.
- Olive Green** All uppersurfaces.
- Dark Green** Mottle over fuselage top, irregular patches on wings, elevators and propeller spinner.
- Black** Tires, propeller blades, exhaust out-lets, engine front and bomb.

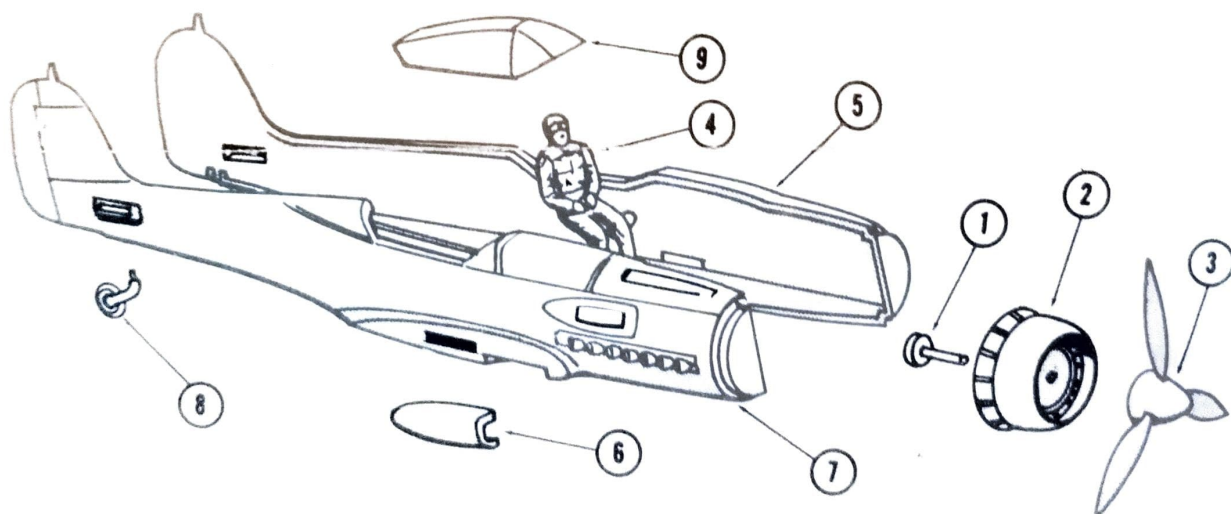

INSTRUCTIONS

1. Insert propeller shaft (1) through rear of engine cowling (2) and cement into propeller (3) be sure no cement gets on cowling. Cement pilot (4) into location on left fuselage half (5). Cement air intake (6) to right half of fuselage (7). Cement fuselage halves together. Locate and cement engine cowling and propeller to fuselage. Cement tailwheel (8) in place beneath fuselage. Be careful not to smear cement onto canopy (9) while cementing it in position.

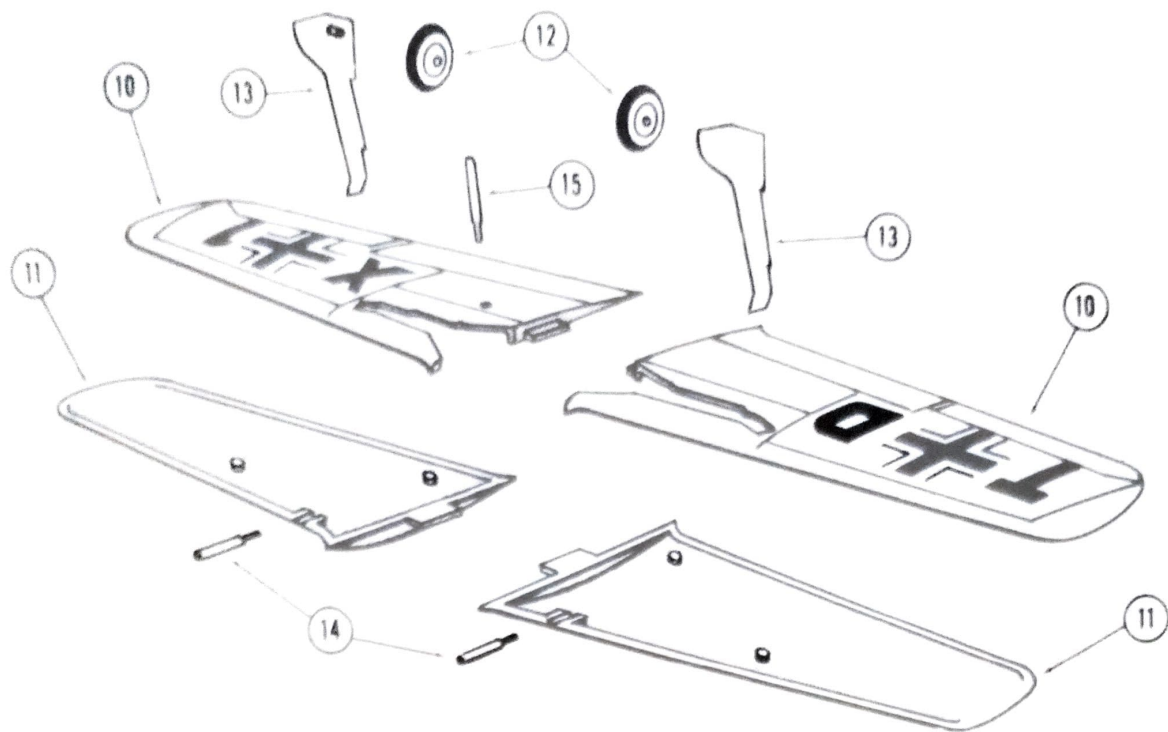

2. Cement left upper and lower wing halves (10,11). Cement wheel (12) onto landing gear leg (13). Then cement leg into location on underside of wing. Note: If you are building your model with the landing gear retracted (up), cut off the landing gear leg axles before cementing in place. Cement cannon (14) into locating hole on leading edge of wing and radio antenna (15) in locating hole beneath wing. Repeat for right wing.

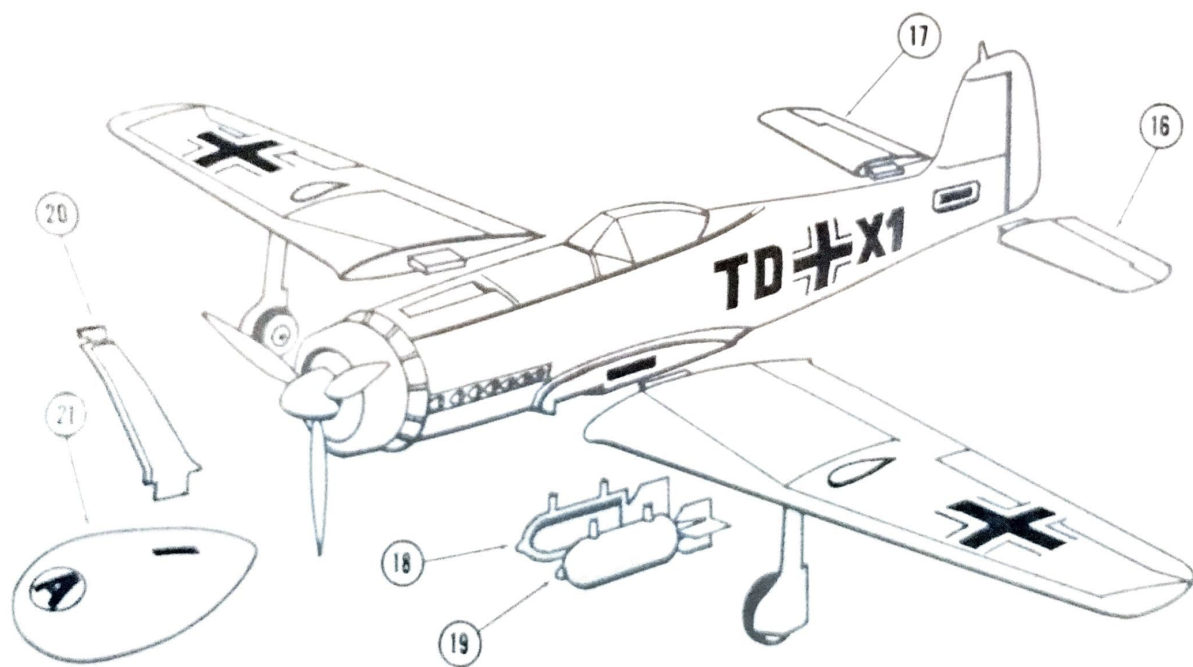

3. Cement left and right wing assemblies to fuselage. Cement elevators (16,17) into fuselage slots. Cement together two bomb halves (18,19) and locate pins in holes beneath fuselage. The location of decals is shown on the box top and in the sketch above. Cut decals apart with scissors, dip into water for a few moments and slide off paper backing onto model. Blot with a soft cloth. Cement together both parts of the display stand (20,21). Cement arm of stand into slot in bottom of fuselage.

FOR REPLACEMENT OF PARTS send name of kit, name and number of parts, together with a stamped self-addressed envelope to **M.P.C.,** **AIRFIX DIVISION**

128 GROESBECK HIGHWAY · MT. CLEMENS, MICHIGAN