

A-4M SKYHAWK

Light Attack Aircraft

美国轻型攻击机 A-4M “天鹰”

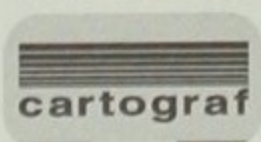

2IN1

1/48
SCALE

美国轻型攻击机 A-4M “天鹰” A-4M Skyhawk Light Attack Aircraft

20世纪50年代初，美国海军和美国海军陆战队提出了研发喷气式攻击机的需求，道格拉斯公司组织了由埃德·海涅曼 (Ed Heinemann) 主持的研发团队，负责开发A-4“天鹰”单座亚音速喷气式攻击机，以替代日益老旧的道格拉斯A-1“天鹰者”螺旋桨攻击机。

“天鹰”中标后的1952年6月12日，海军与道格拉斯公司签订了采购合同，根据美国海军1962年之前的命名原则，“天鹰”最初被命名为A4D。

“天鹰”是一款紧凑、简单、结实且易于维护的轻型战术攻击机。其最大起飞重量为11,100公斤，只有海军提出的重量需求的一半左右。“天鹰”采用短翼展三角翼，机翼非常紧凑，无需折叠机翼即可在航母上使用，这也满足了当时尚在服役的二战航母对新型舰载机的需求。

“天鹰”采用前三点式起落架，由一台涡轮喷气发动机提供动力。其挂载点支持各种导弹、炸弹和其他弹药的挂载。早期的“天鹰”能够携带相当于二战时期B-17轰炸机的武器载荷；早期型号还担负着投掷战术核弹的任务，可以用上仰抛投的方式投掷核弹。此外，“天鹰”还开创性的首次使用了“伙伴”空中加油系统，携带此系统后，“天鹰”可以为一同飞行的其他作战飞机补充燃料，从而大大减少了作战行动对专用空中加油机的需求。

A-4非常结实，能够在液压系统出现故障时利用机翼下携带的两个副油箱进行紧急着陆，这种着陆方式会对机头造成轻微的损伤，但此损伤通常可以在不到一个小时的时间内修复。

“天鹰”前500架生产型的平均成本86万美元/架，低于海军最高100万美元/架的价格需求。“天鹰”一经服役，便得到了美国海军和陆战队的认可和喜爱，很快获得了“Scooter”、“Kiddiecar”、“Bantam Bomber”、“Tinker Toy Bomber”，以及因其速度和灵活性能而闻名的“Heinemann's Hot-Rod”的众多绰号。

“天鹰”在越南战争和冷战期间发挥了重要作用。除了装备美国海军和海军陆战队外，“天鹰”也出口到多个国家和地区，参与了冷战期间的大多数著名战争。1979年2月，“天鹰”系列的最后一架飞机下线，其连续27年的生产时长，创下了美国同系列战术军用飞机的生产时长记录。在这个漫长的生产过程中，共生产了2960架各型号的“天鹰”。至今，部分国家的“天鹰”家族战机依然处于服役状态。

1967年，美国海军的“天鹰”开始逐步从一线部队退役，被更大更重的A-7和F-4 Phantom II所取代，“天鹰”则用于执行训练和模拟敌方飞机的任务直到1990年退役。

A-4M是“天鹰”家族的最后型号，由A-4F改进而来，以满足美国海军陆战队对“天鹰”短距起降和近距离空中支援作战的需求。

A-4M是“天鹰”家族最强一代：使用推力更大的J52-P-408发动机；换装较高的座舱盖来改善飞行员的视野；加装了在地面机场使用的减速伞；安装了新的敌我识别天线(IFF)；重新设计了向右弯曲的固定式空中受油管启动系统。此外，A-4M装备了当时性能领先的电子设备和角度/速率轰炸系统 (ARBS)，用于捕获和跟踪激光标定的目标。A-4M装备的两门20mm航炮的携弹量也增加了一倍，五个武器外挂点的武器载荷达到了近4000公斤。

在A-4M服役的10年时间内，共生产了160架（其中两架改进自A-4F），1979年2月27日下线的最后一架A-4M被划拨给了VMA-331“大黄蜂”中队。

A-4M是美国除A-4A之外唯一没有参加实战的“天鹰”家族型号。1971年越南战争逐渐进入尾声时A-4M开始服役，而在海湾战争前的1990年2月A-4M退出服役转入后备役，颇有命运不济的感觉。从装备到退役，A-4M一直部署在日本，为一场随时有可能爆发的战争做着准备。然而，A-4M的出口改进型号A-4N和A-4Ku则经历了战火的考验并被飞行员和航空爱好者津津乐道。

The Skyhawk was developed and designed by Douglas Aircraft's Ed Heinemann during the early 1950s on behalf of the US Navy and United States Marine Corps as a replacement for the piston-powered Douglas AD Skyraider.

The Navy issued a contract for the type on 12 June 1952. It was originally designated "A4D" under the United States Navy's pre-1962 designation system.

The A-4 is a compact, straightforward, and lightweight aircraft for the era. Its maximum takeoff weight of 24,500 pounds (11,100 kg) being roughly half of the Navy's weight specification.

The Skyhawk has a short-span delta wing configuration which can be used on an aircraft carrier without folding the wings, also met the needs of the WWII aircraft carriers were still in service at that time for new carrier-based aircraft.

The Skyhawk has a tricycle undercarriage, and is powered by a single turbojet engine. The Skyhawk's five hardpoints support a variety of missiles, bombs, and other munitions. It is capable of carrying a bomb load equivalent to that of the WWII-era Boeing B-17 bomber, and can deliver nuclear weapons using a low-altitude bombing system and a "loft" delivery technique.

Furthermore, it pioneered the concept of "Buddy" air-to-air refueling, enabling an aircraft to supply others and reduce the need for dedicated aerial tankers.

The A-4 was also designed to be able to make an emergency landing, in the event of a hydraulic failure, on the two drop tanks nearly always carried by these aircraft. Such landings resulted in only minor damage to the nose of the aircraft which could be repaired in less than an hour.

The first 500 production examples cost an average of \$860,000 each, less than the Navy's one million dollar maximum. The diminutive Skyhawk soon received the nicknames "Scooter", "Kiddiecar", "Bantam Bomber", "Tinker Toy Bomber", and, on account of its speed and nimble performance, "Heinemann's Hot-Rod".

Skyhawks were the US Navy's primary light attack aircraft used during the Vietnam War and Cold War. Besides the U.S. Navy and USMC, other nations and regions are also used Skyhawks in the actions during Cold War era. The Skyhawk was in production through to February 1979, by which point 2,960 aircraft had been delivered to a variety of operators. Till now, the "Skyhawk" of some countries are still in service.

Although the A-4's use as a training and adversary aircraft would continue well into the 1990s, the Navy began removing the aircraft from its frontline attack squadrons in 1967, replaced by the A-7 and F-4 Phantom II.

The last version of the Skyhawk series to be built, the A-4M Skyhawk, improved from A-4F and was designed specifically for use by the U.S. Marine Corps.

The A-4M was a further advancement of the Skyhawk. This model boasted several improvements over previous iterations, including the much more powerful J52-P-408 engine, a larger cockpit canopy for superior pilot visibility, a ribbon-type drag chute to slow down the aircraft on landing, a square-edged stabilizer to incorporate installation of the IFF antenna, as well as a reworked refueling probe and engine starter system. Later fitted with Hughes AN/ASB-19 Angle Rate Bombing System (ARBS) with TV and laser spot tracker. The ammunition capacity of the A-4M's twin 20mm Colt Mk.12 cannons has also been doubled, with a weapons load of nearly 4,000 kilograms on five external hardpoints.

A total of 160 A-4M Skyhawks were built (2 from A-4F) in 10 years. The final A-4M was delivered on February 27, 1979, to the "Bumblebees" of VMA-331, bringing Skyhawk production to an end.

The A-4M is the only Skyhawk other than the A-4A that has not participated in combat. The A-4M entered service in 1971 when the Vietnam War was coming to an end and in February 1990, before the Gulf War, the A-4M was transferred to the reserve service. During A-4M's service, it has been deployed in Japan, preparing for a war that may break out. However, the export improved series A-4N and A-4Ku, have been tested in the war instead of the A-4M.

制作前请仔细阅读以下内容 Read carefully before assembly

注意

- 本模型适合的最小年龄为14周岁，14周岁以下制作时应当有家长陪同。
- 请勿吞食产品包装中的物品，包括但不限于零件、说明书、包装袋等。
- 将零件取出后应立即丢弃包装袋，请勿将包装袋置于口鼻处或套在头上，以免引起窒息。
- 请勿将本产品置于明火或者高温源附近。

Caution

- This model kit is for user aged 14 or above. User under 14 should be accompanied by parents when building this kit.
- Don't swallow any items in the package, including but not limited to parts, stickers, manual and vinyl bags.
- Please throw the vinyl bags away once you unpacked parts. Don't put the bags onto mouth, nose or over the head to avoid suffocation.
- Keep this product away from fire or high temperature source.

使用工具 Tools recommended

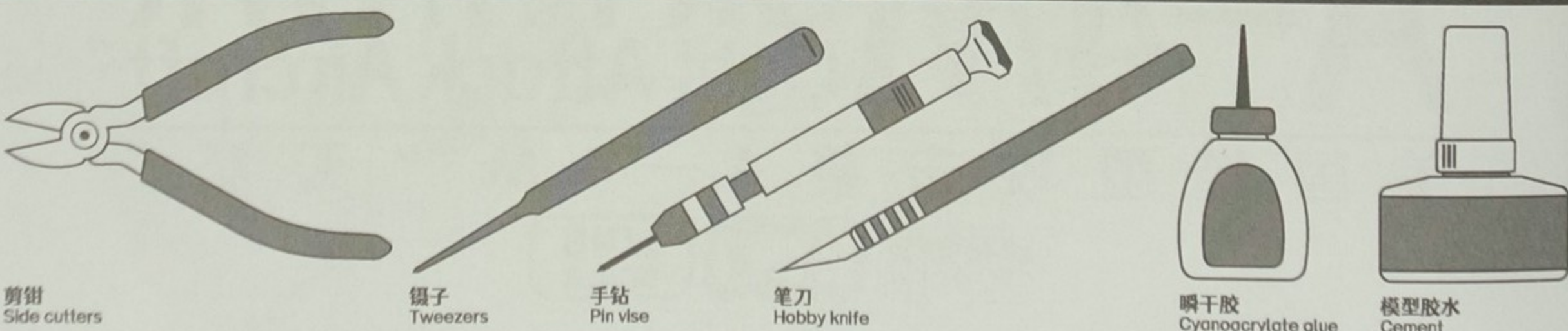

图标说明 Icon



优先制作
Assemble first



对称制作
Both sides

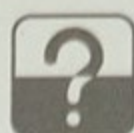

选择其一
Choose one



使用贴纸
Apply decal



使用瞬干胶
Apply CA cement



钻孔
Drill hole

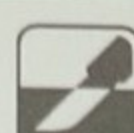

切除
Cut

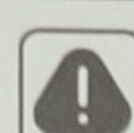

注意
Caution

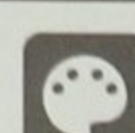

需要上色
Paint

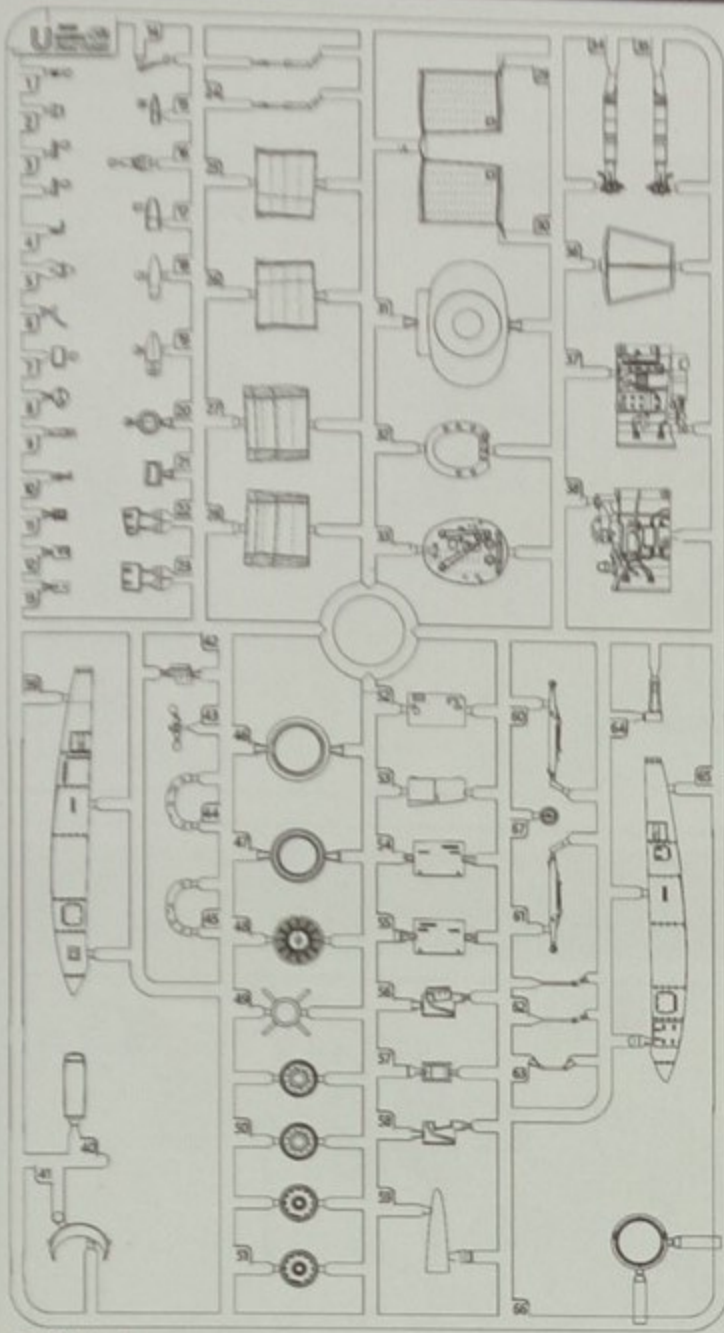

板件U x1
Parts U x1

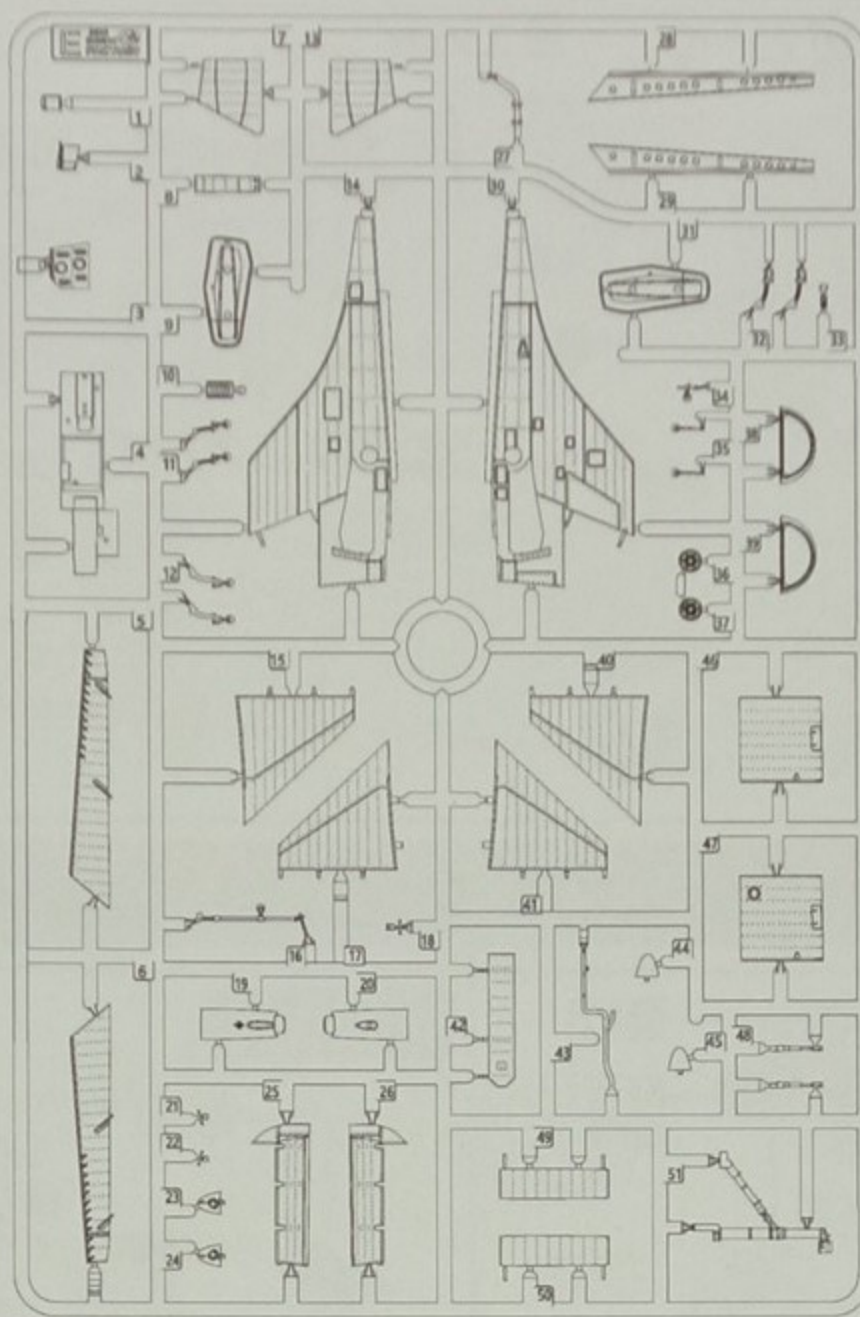

板件E x1
Parts E x1

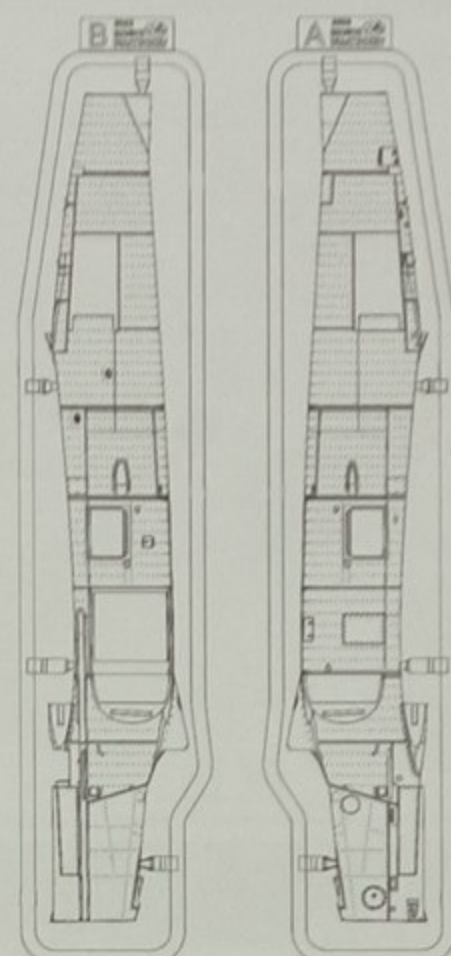

板件B x1
Parts B x1

板件A x1
Parts A x1

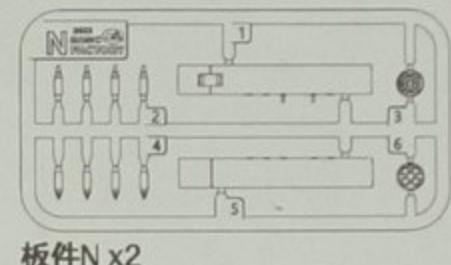

板件N x2
Parts N x2

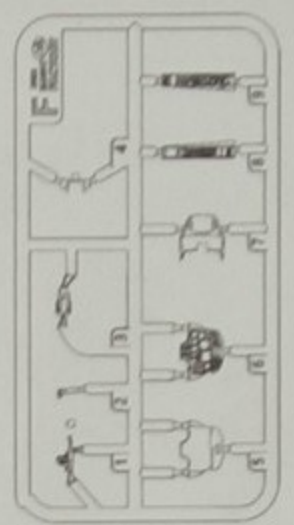

板件F x1
Parts F x1

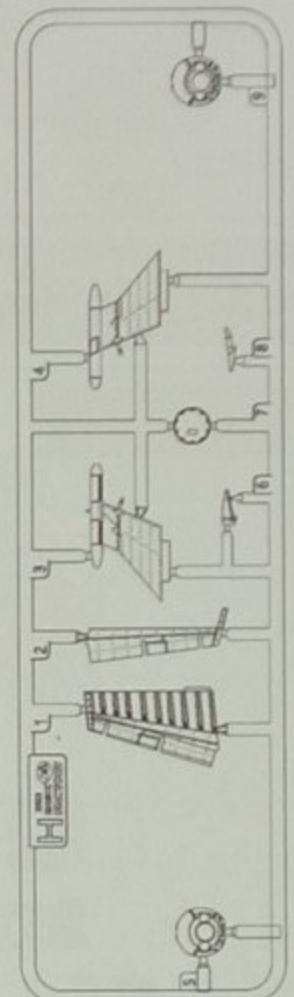

板件H x1
Parts H x1

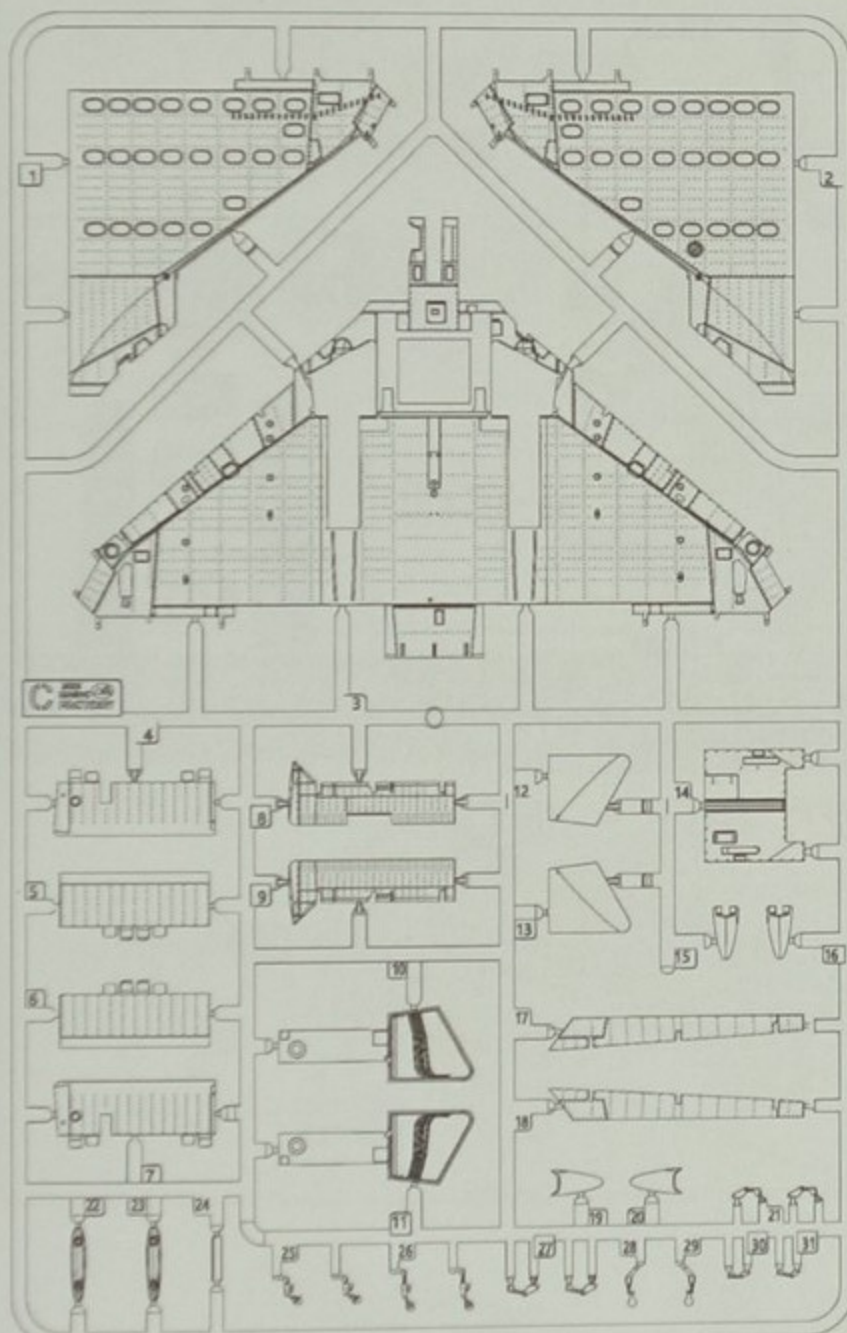

板件C x1
Parts C x1

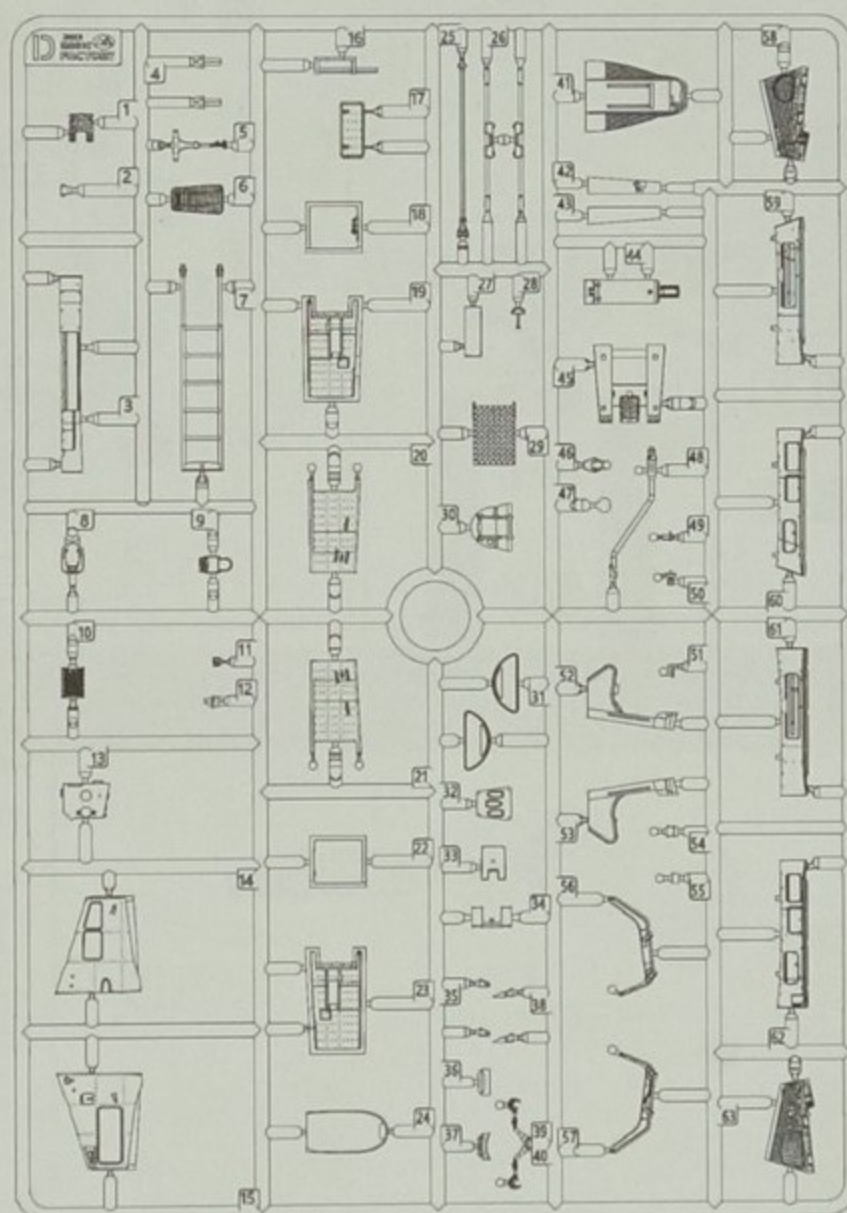

板件D x1
Parts D x1

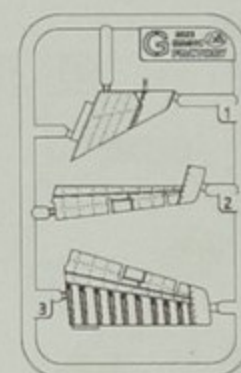

板件G x1
Parts G x1



前起落架轮 x1
Front Wheel x1

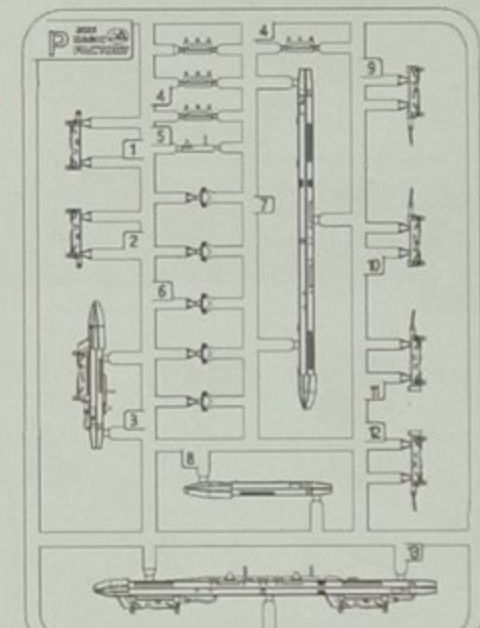

板件P x2
Parts P x2

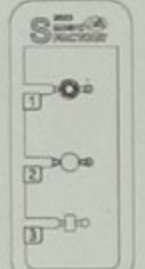

板件S x1
Parts S x1

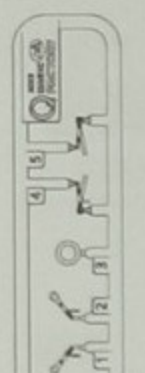

板件Q x1
Parts Q x1

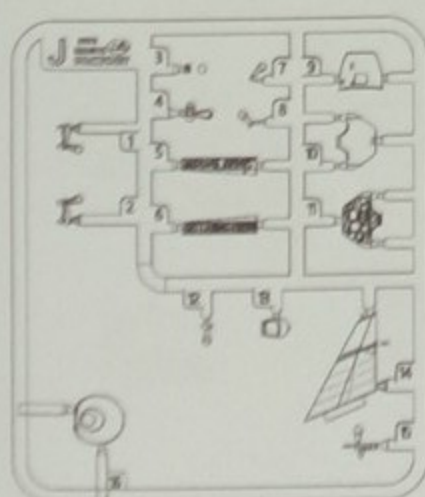

板件J x1
Parts J x1

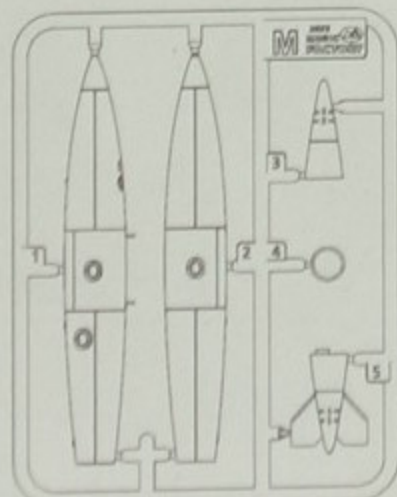

板件M x2
Parts M x2

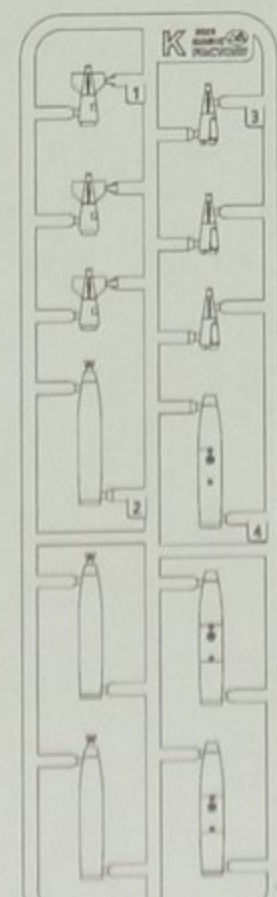

板件K x2
Parts K x2

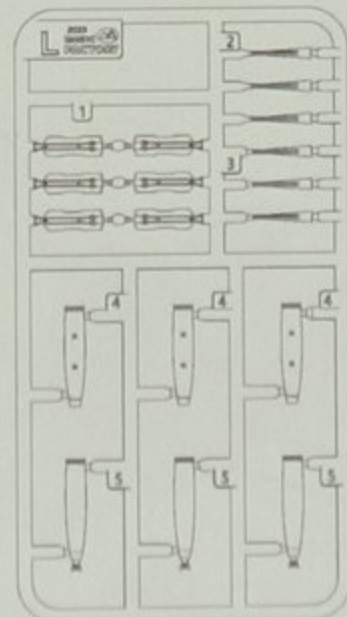

板件L x2
Parts L x2

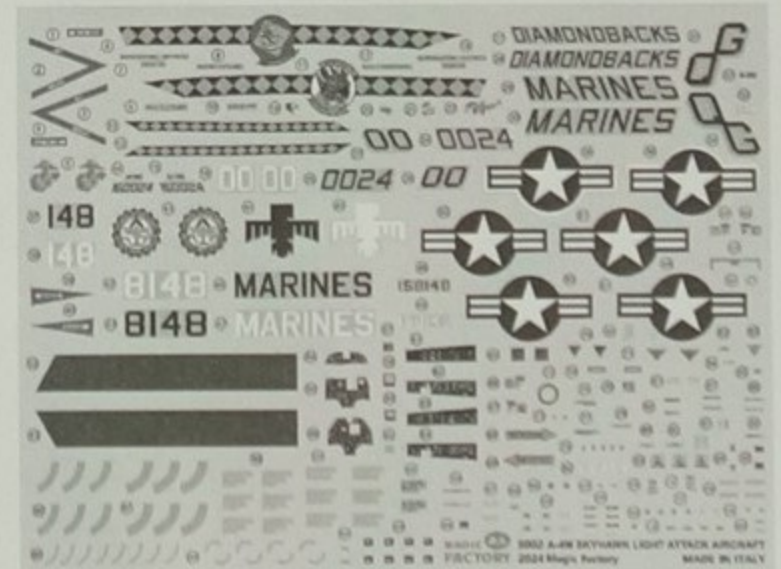

水贴 x1
Decal x1

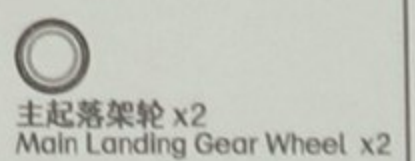

主起落架轮 x2
Main Landing Gear Wheel x2

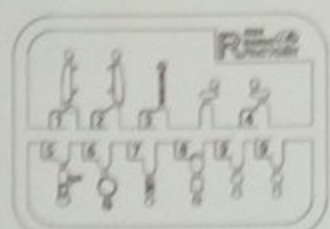

板件R x1
Parts R x1

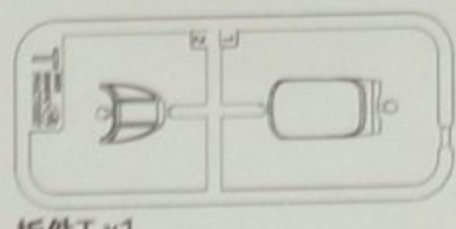

板件T x1
Parts T x1



PE x1
PE x1



遮盖贴 x1
Mask Sticker x1

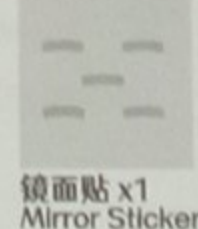

镜面贴 x1
Mirror Sticker x1

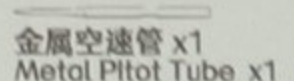

金属空速管 x1
Metal Pitot Tube x1

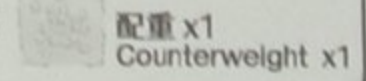

配重 x1
Counterweight x1

1. 弹射座椅组装 Ejection Seat Assembly

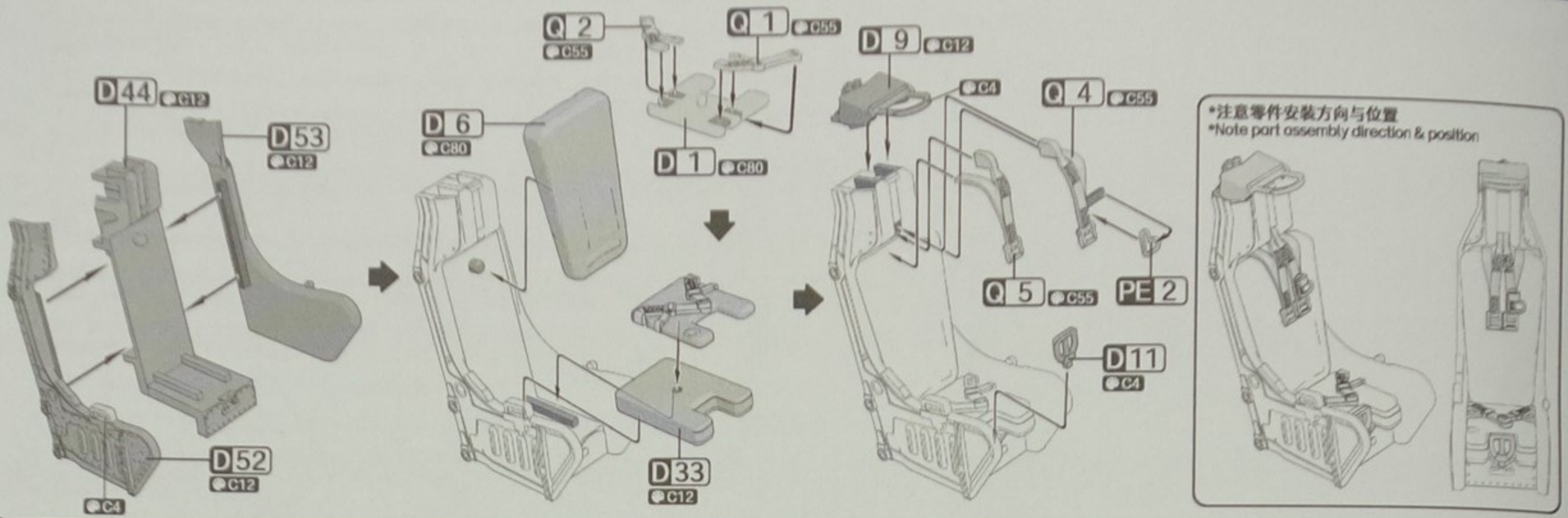

2. 座舱组装 Cockpit Assembly

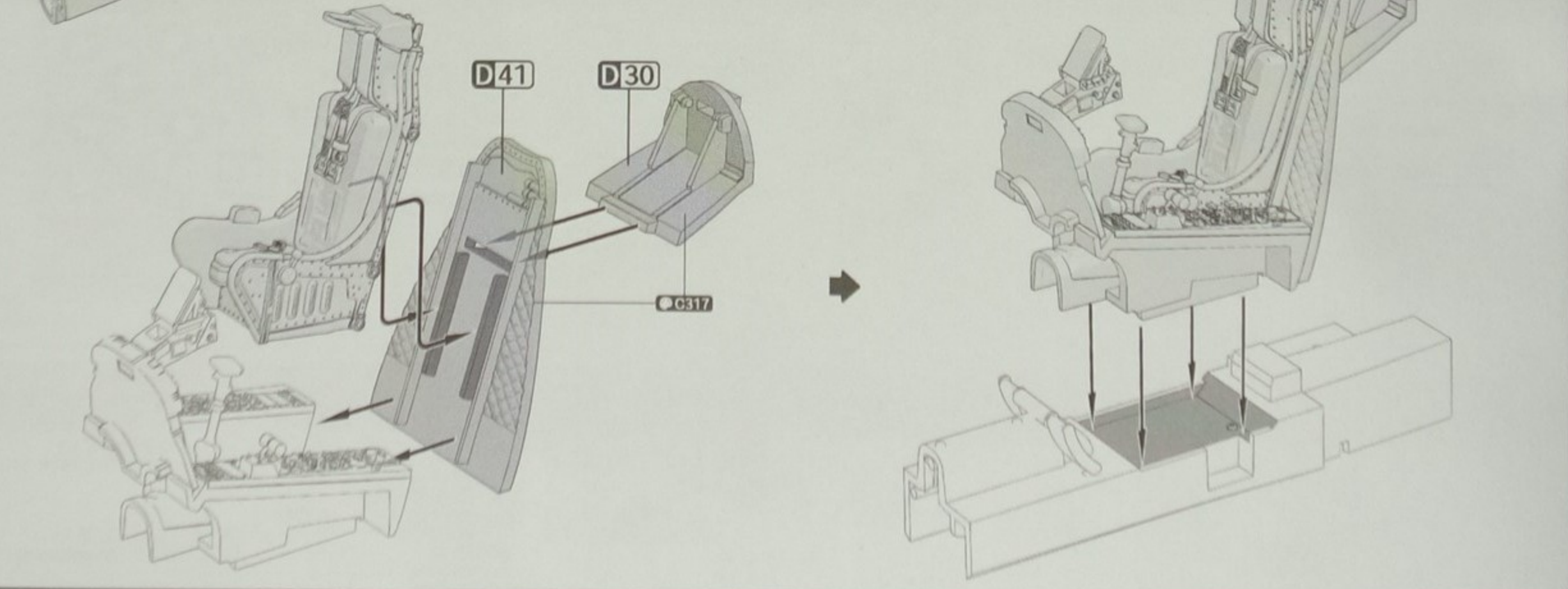
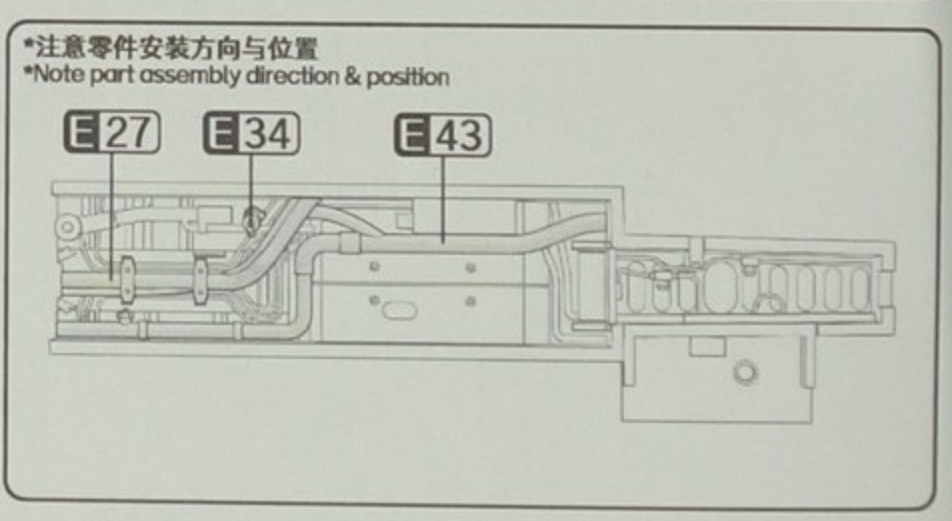
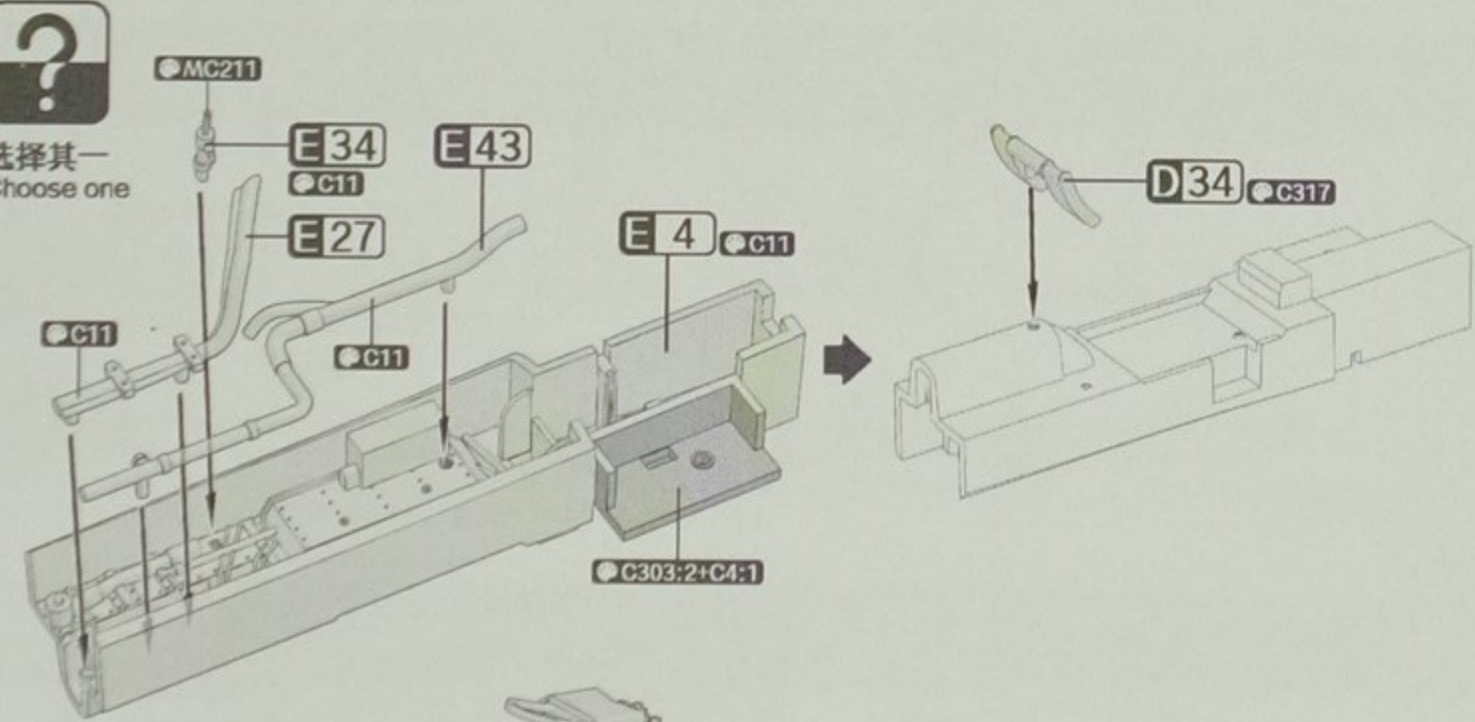
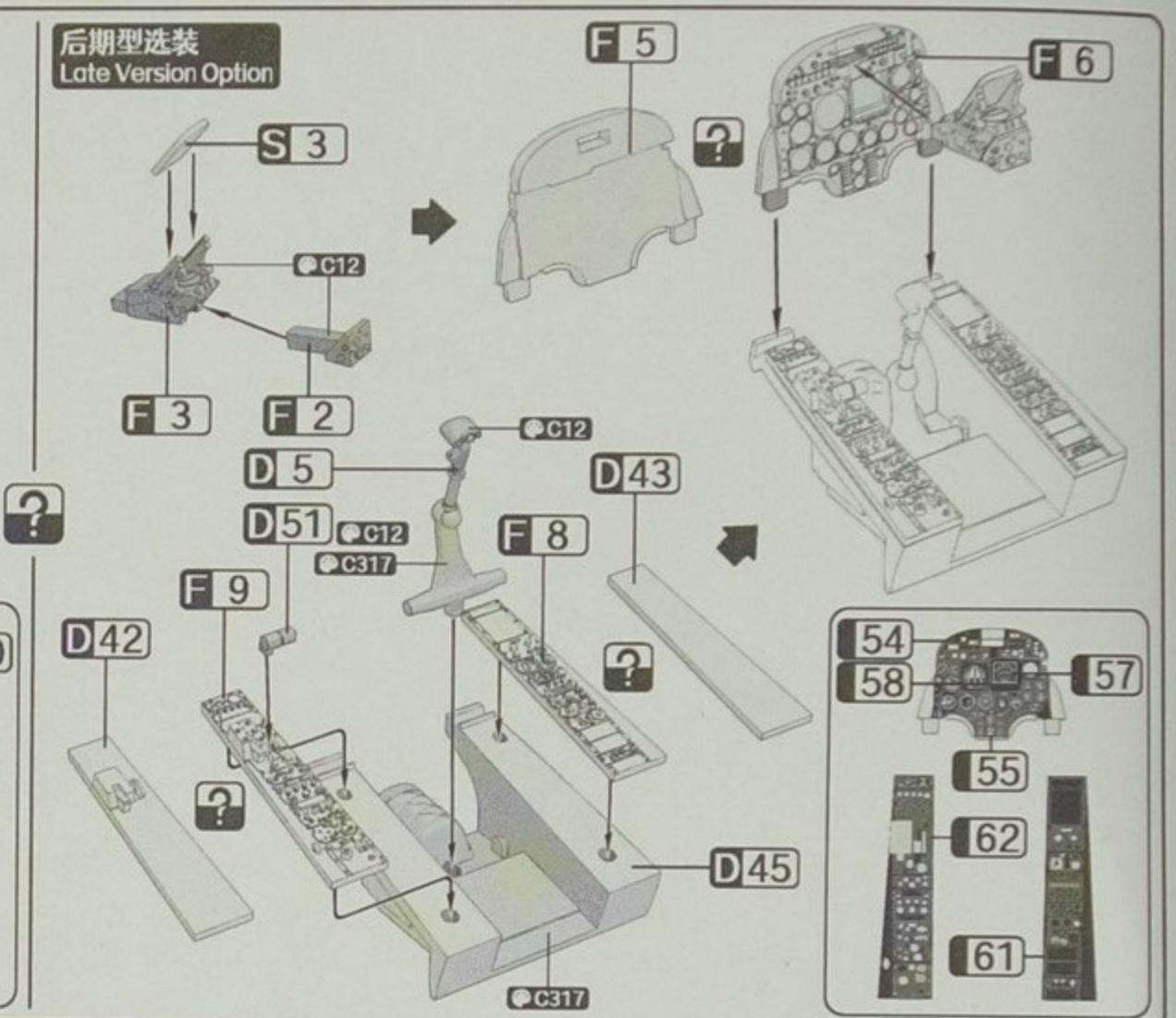
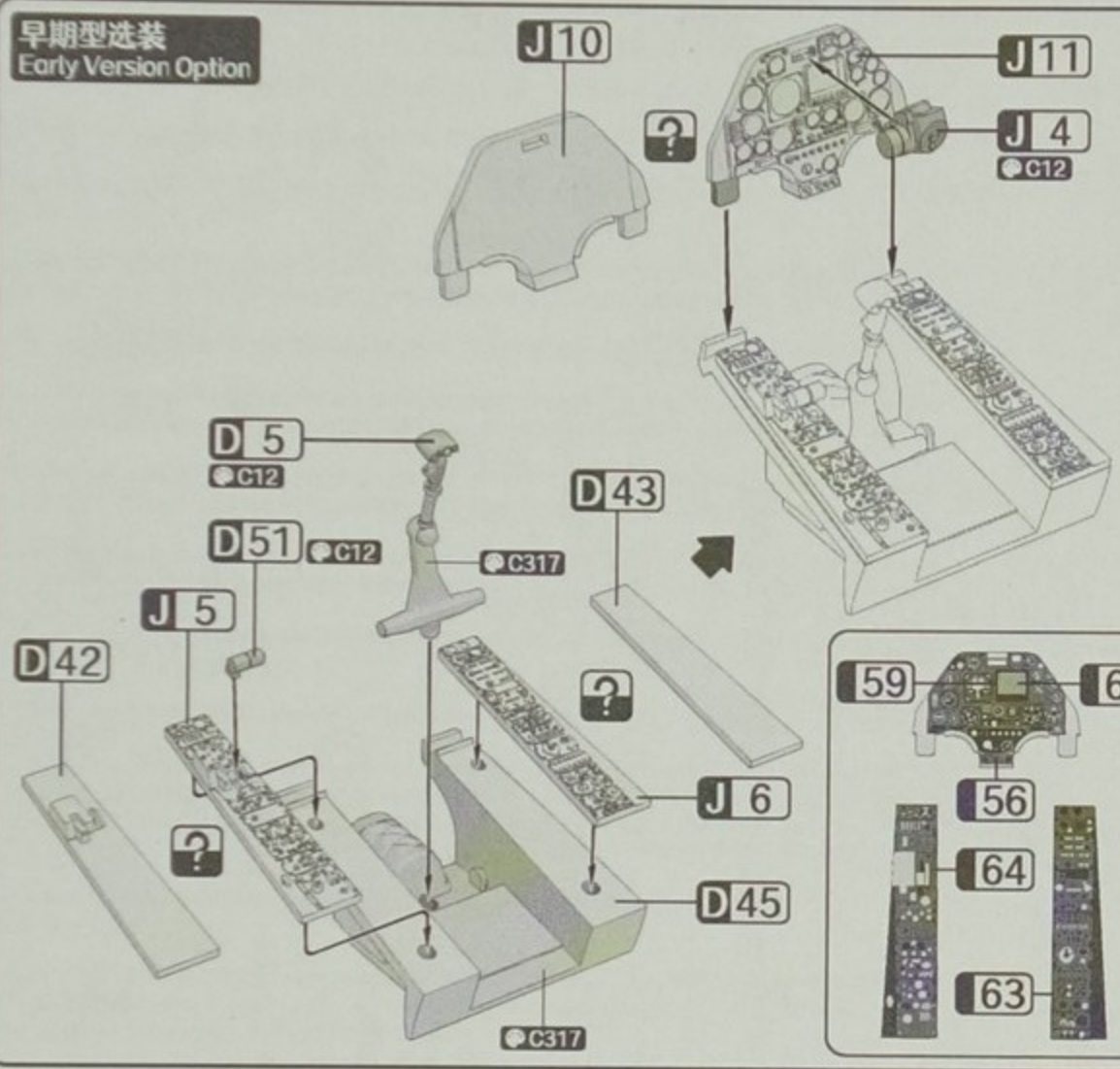

3. 机身附件组装 Fuselage Accessories Assembly

注意打孔
Drill Hole

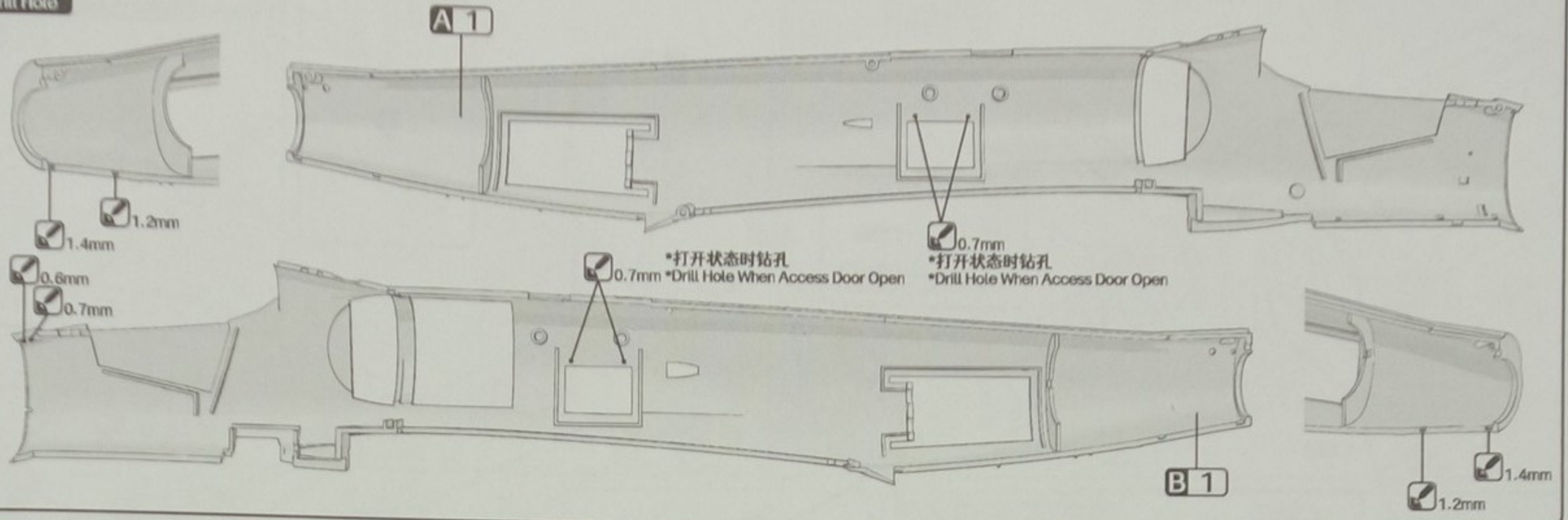

 钻孔
Drill hole
  选择其一
Choose one

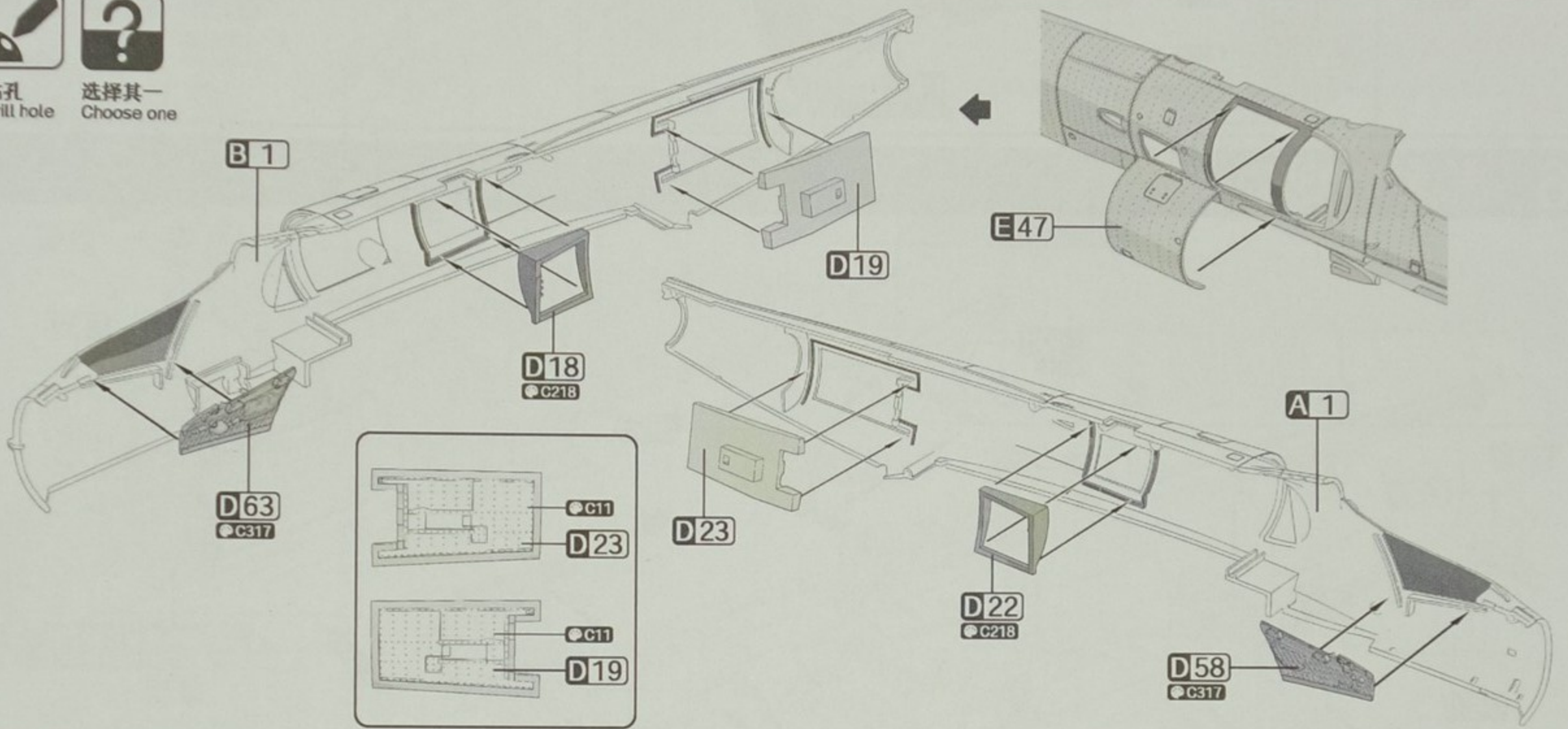

4. 机身组合 Fuselage Assembly

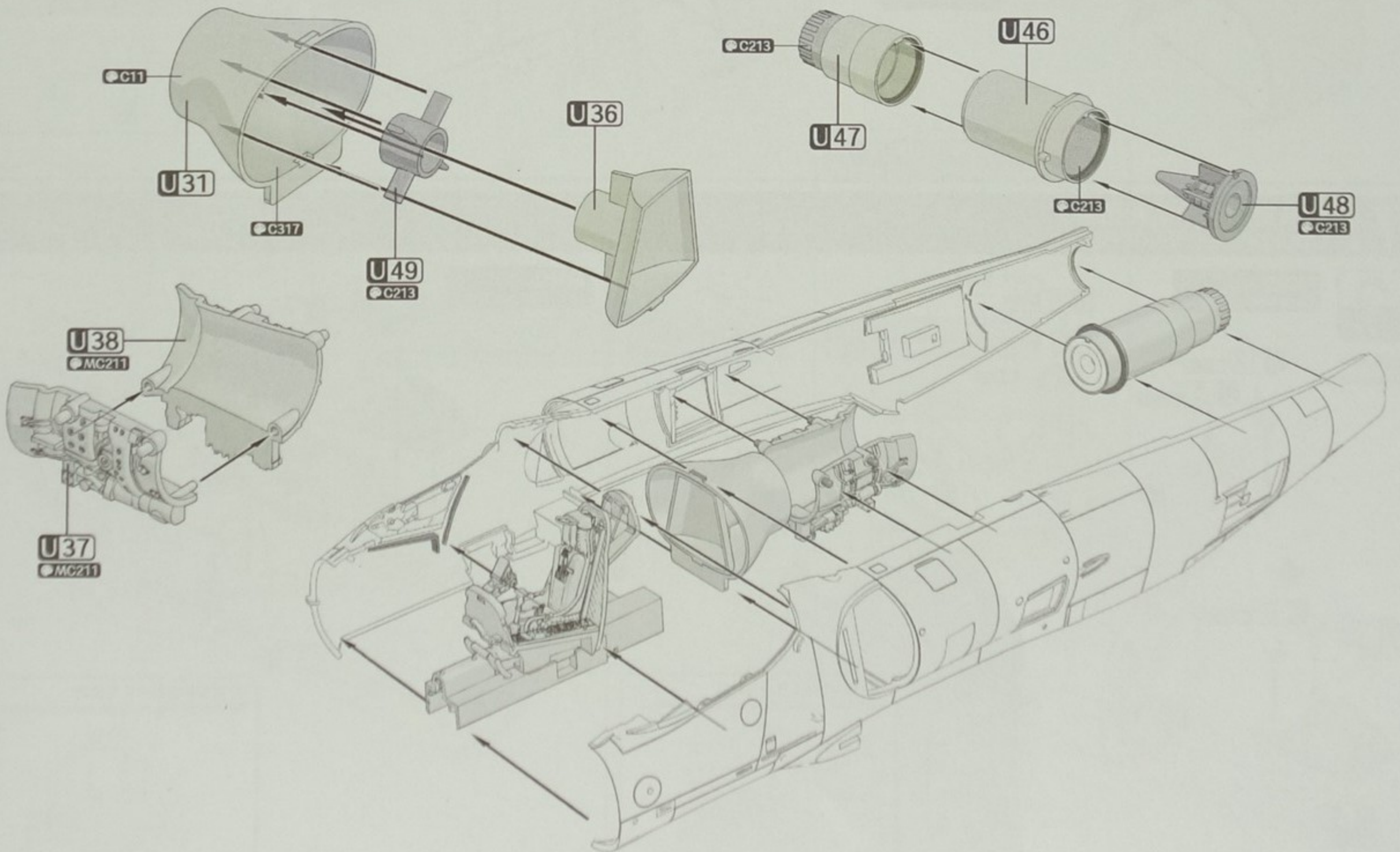

5. 机身附件组装 Fuselage Accessories Assembly

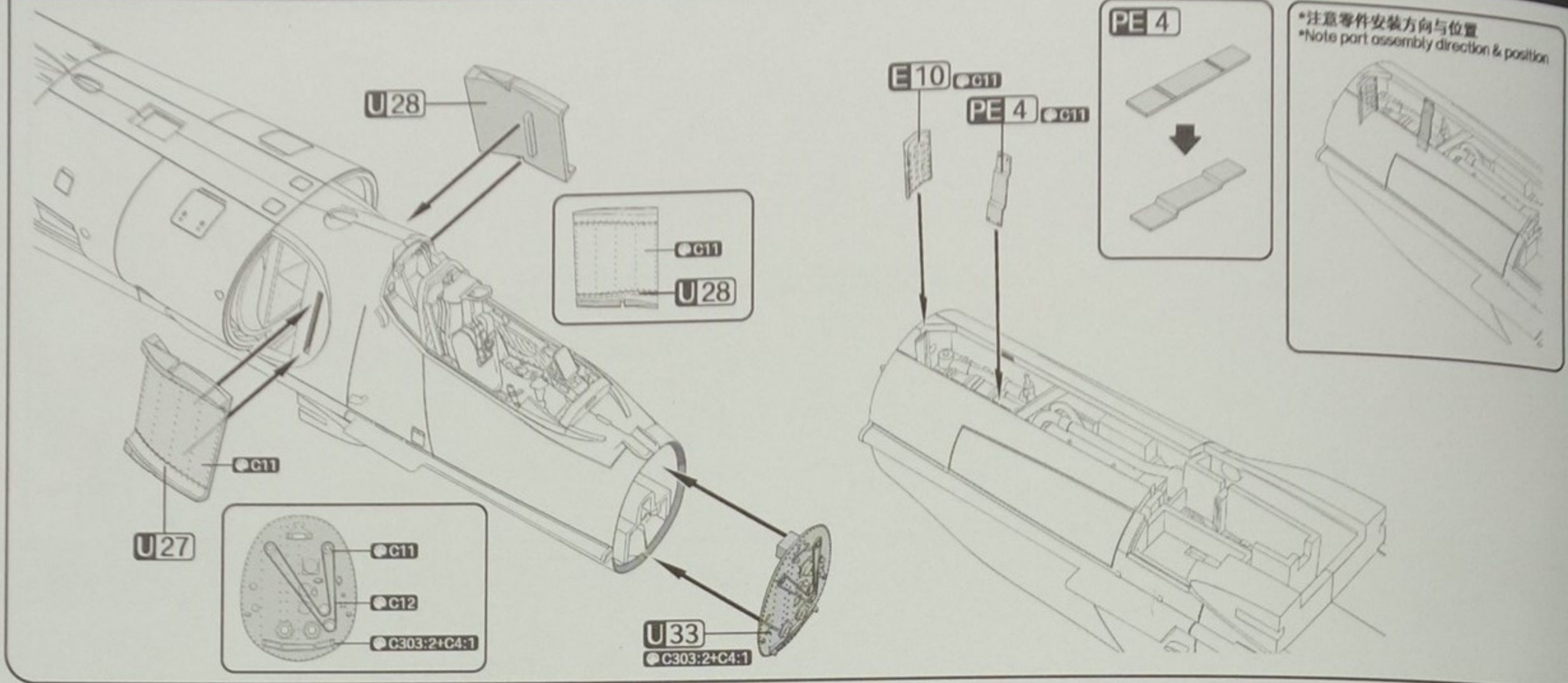

6. 进气道组装和组合 Inlet Duct Assembly

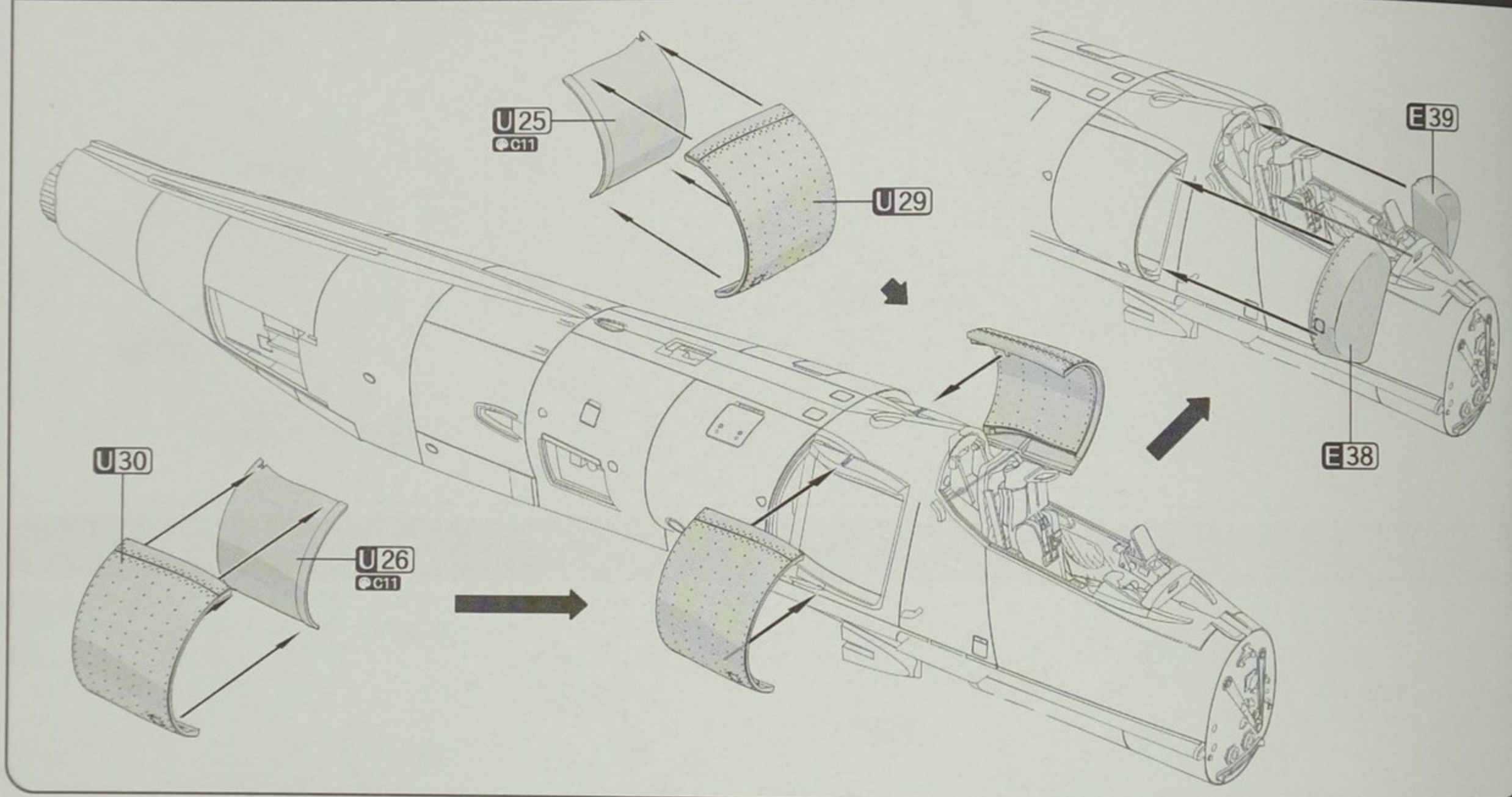

7. 仪表遮阳板组装和组合 Cockpit Sun Visor Assembly

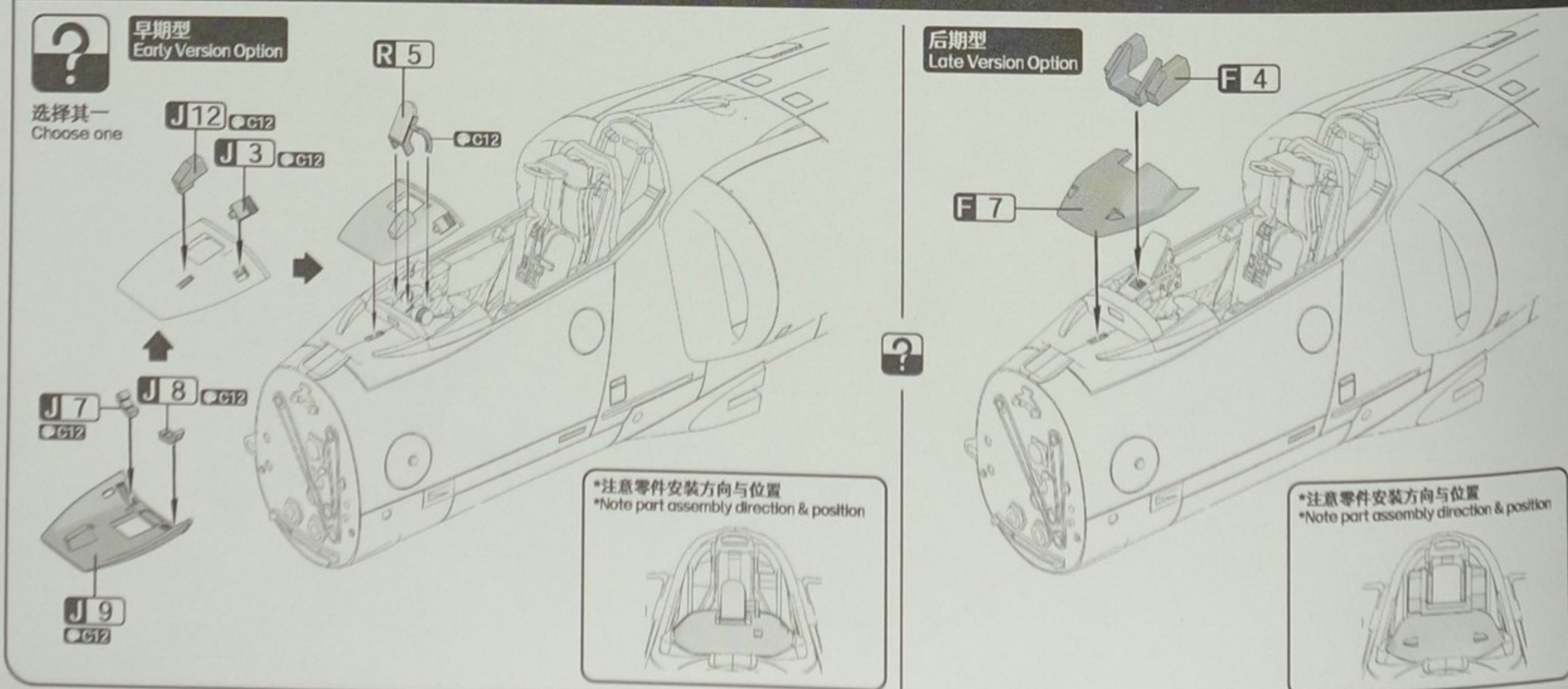

8. 机翼组装与组合 Wings Assembly

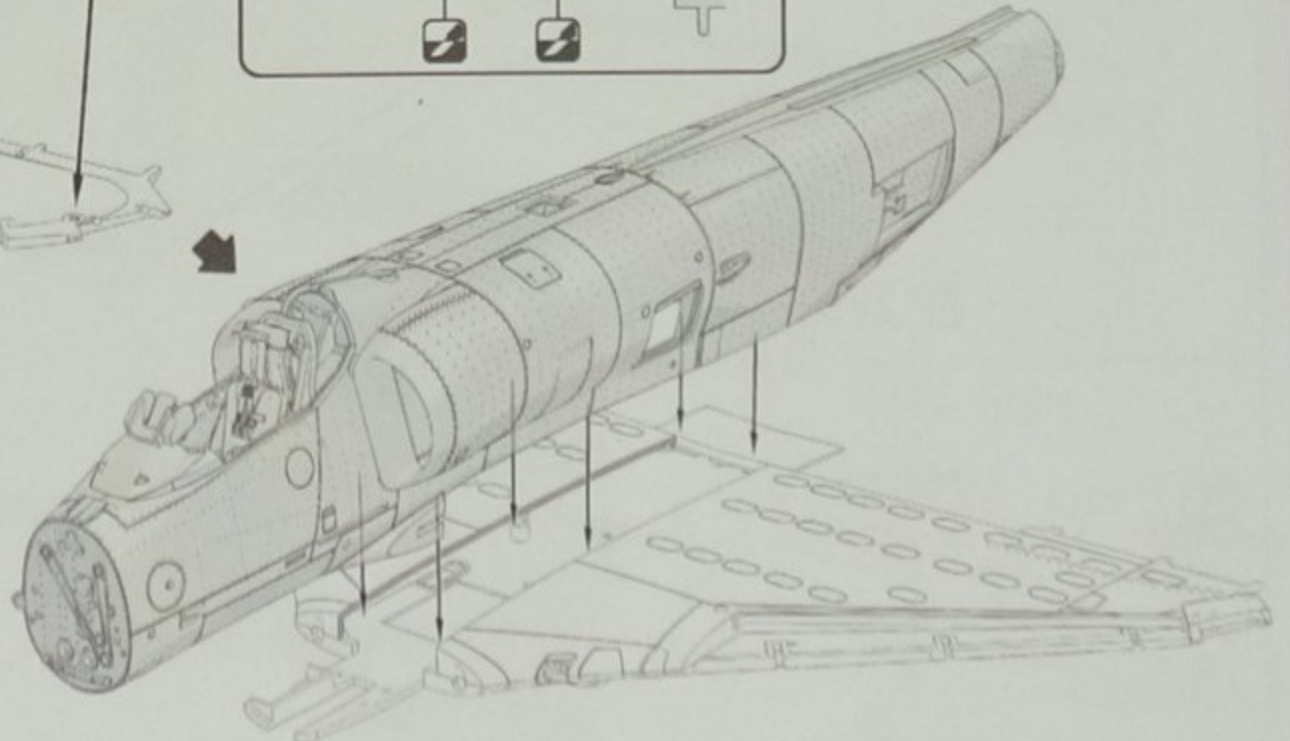
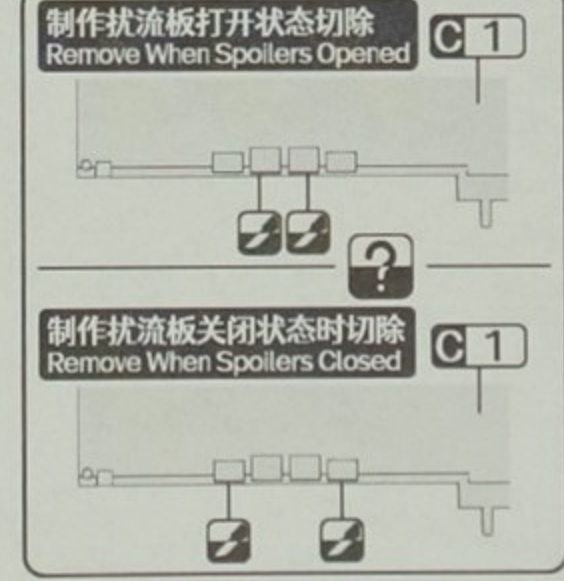
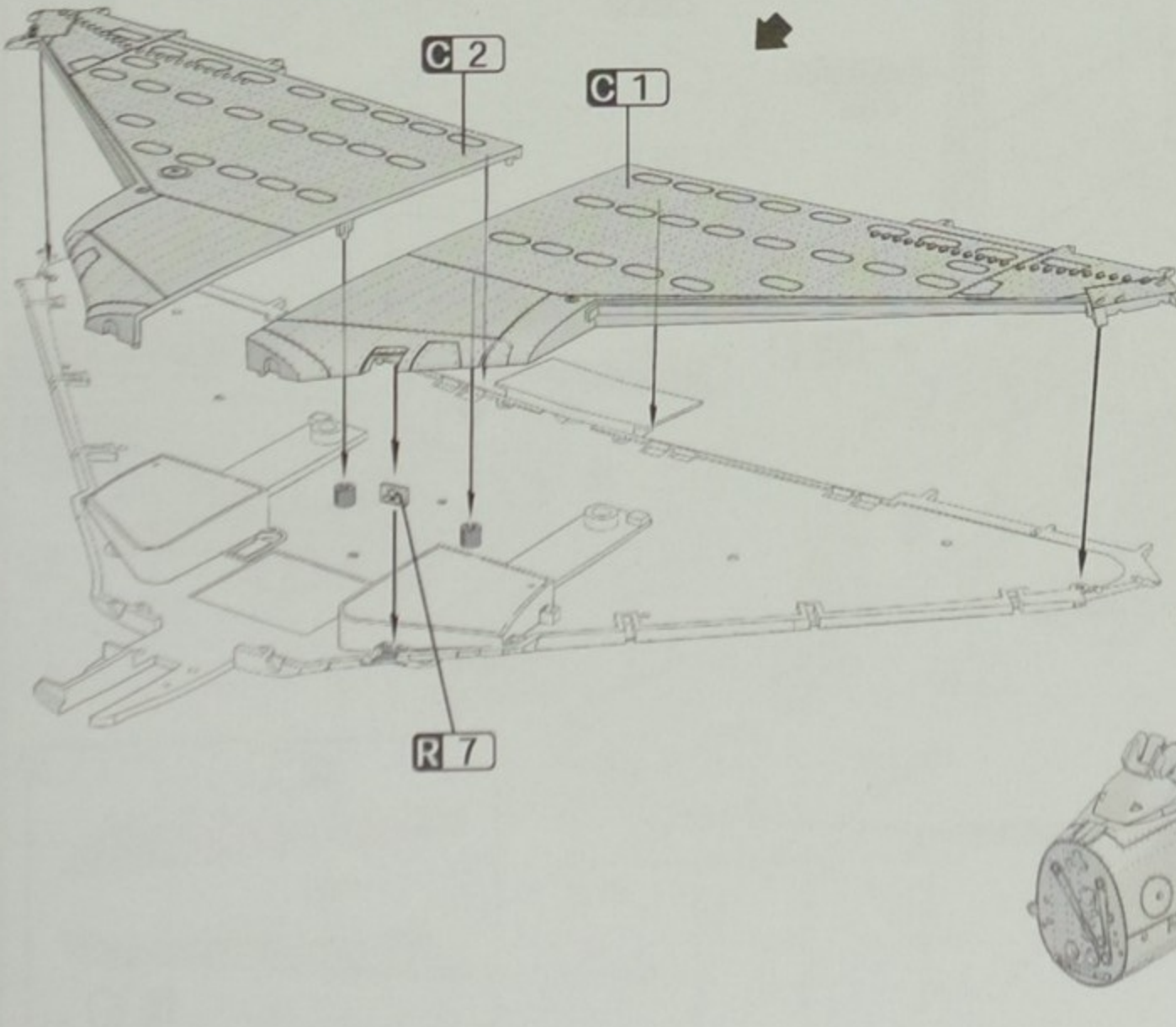
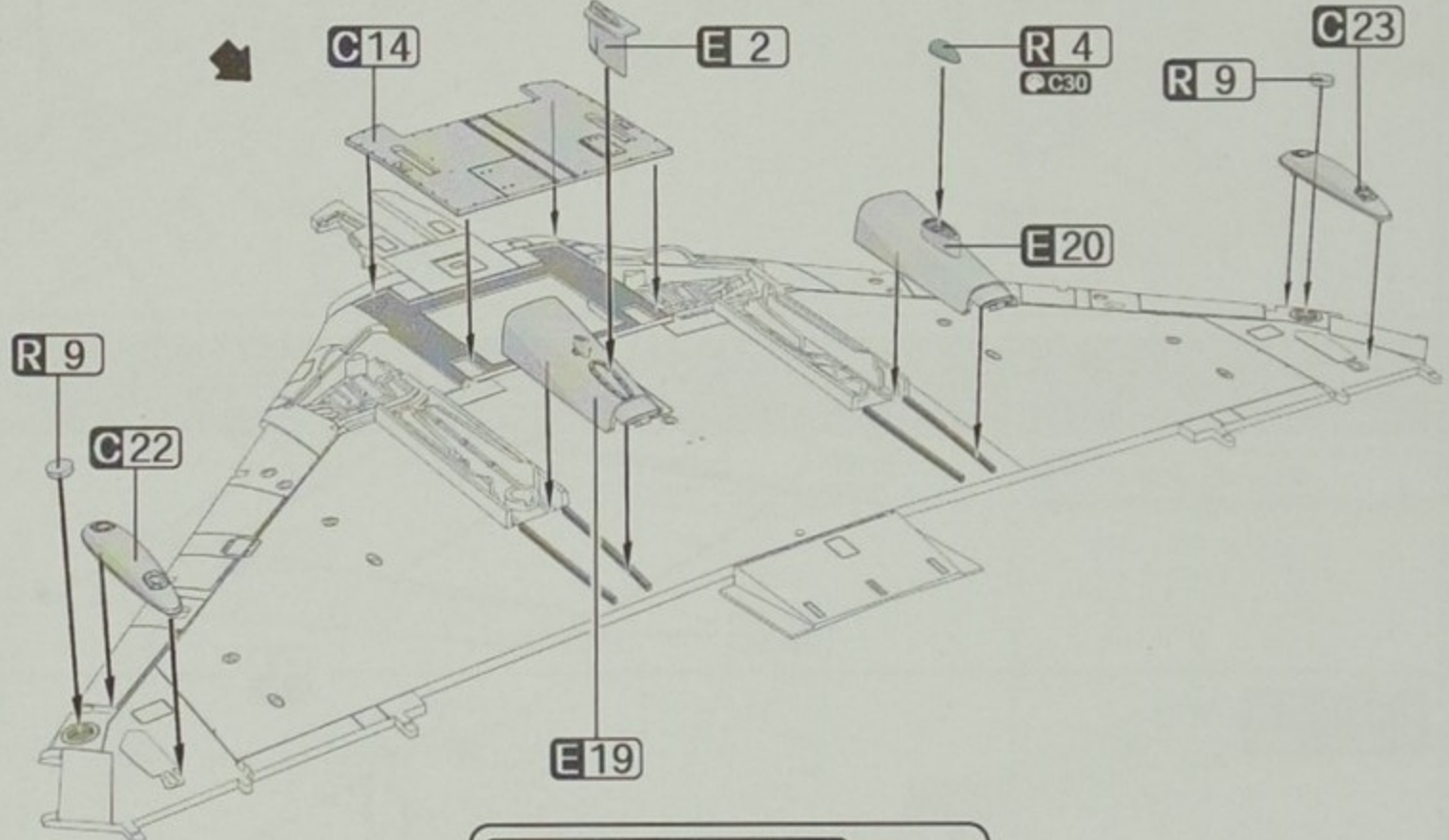
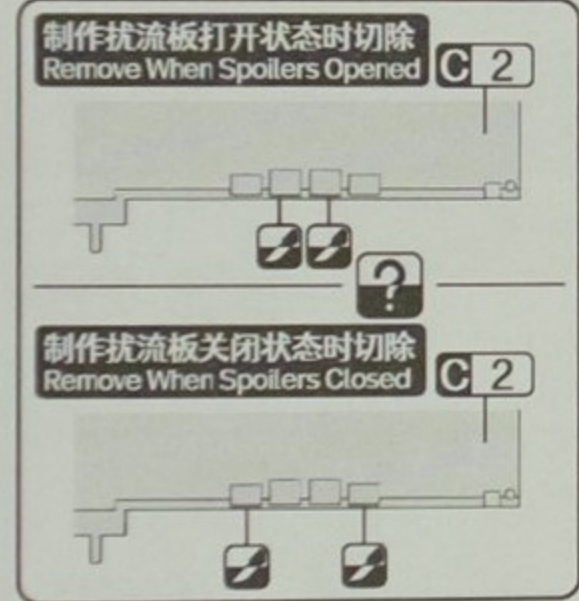
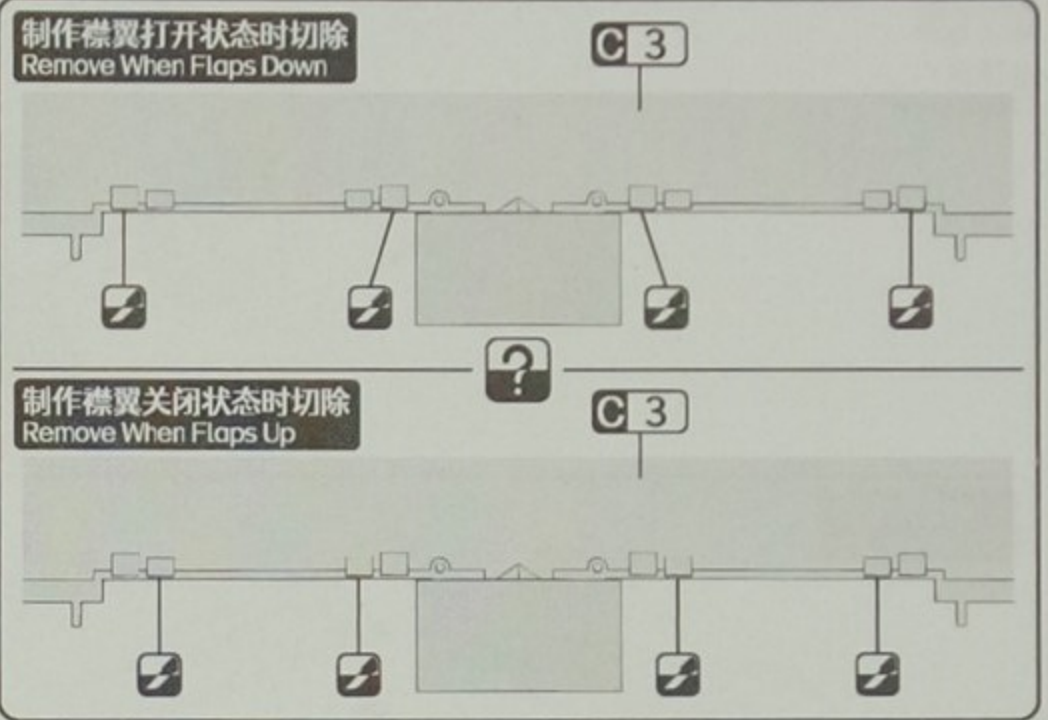
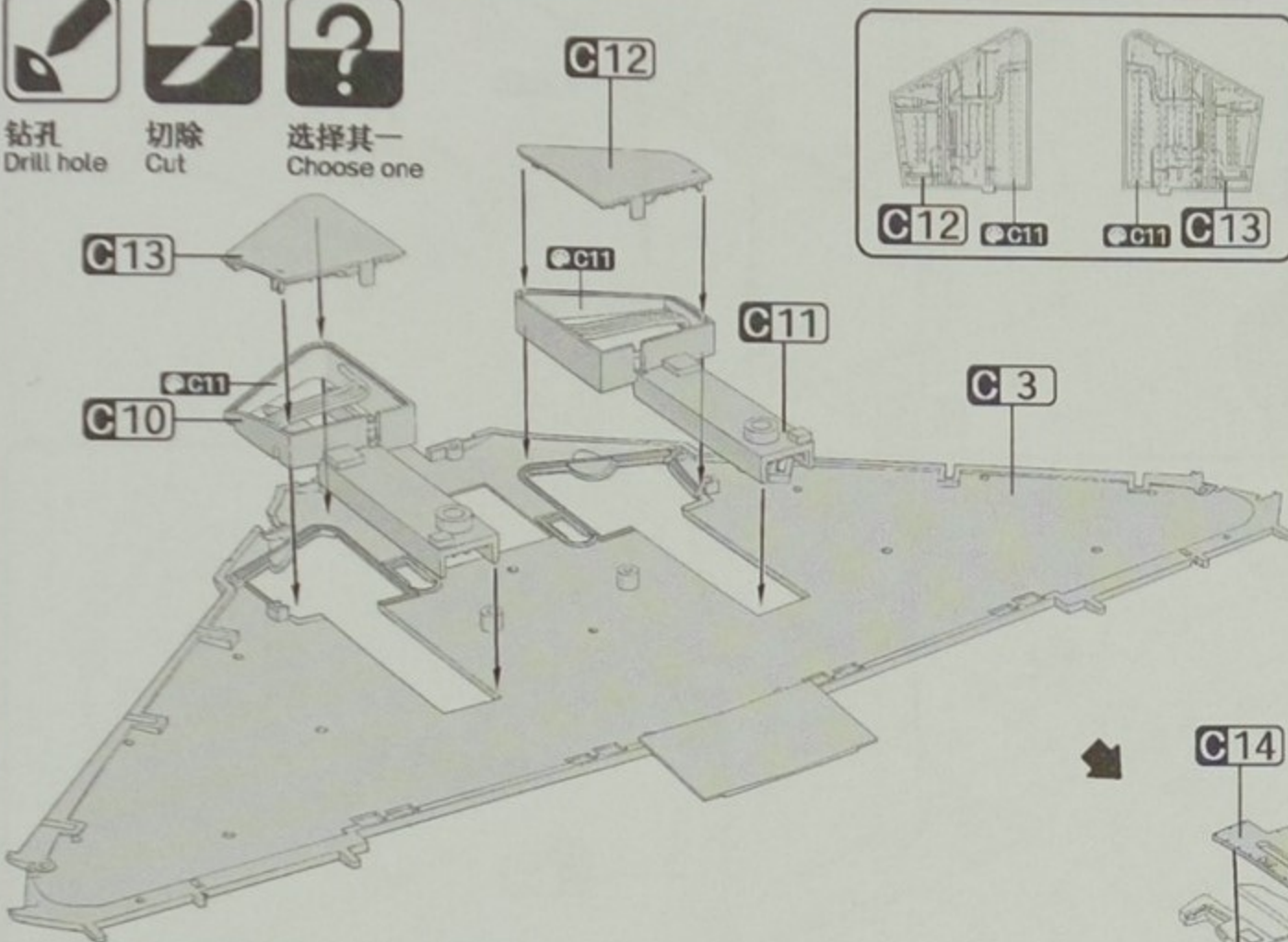
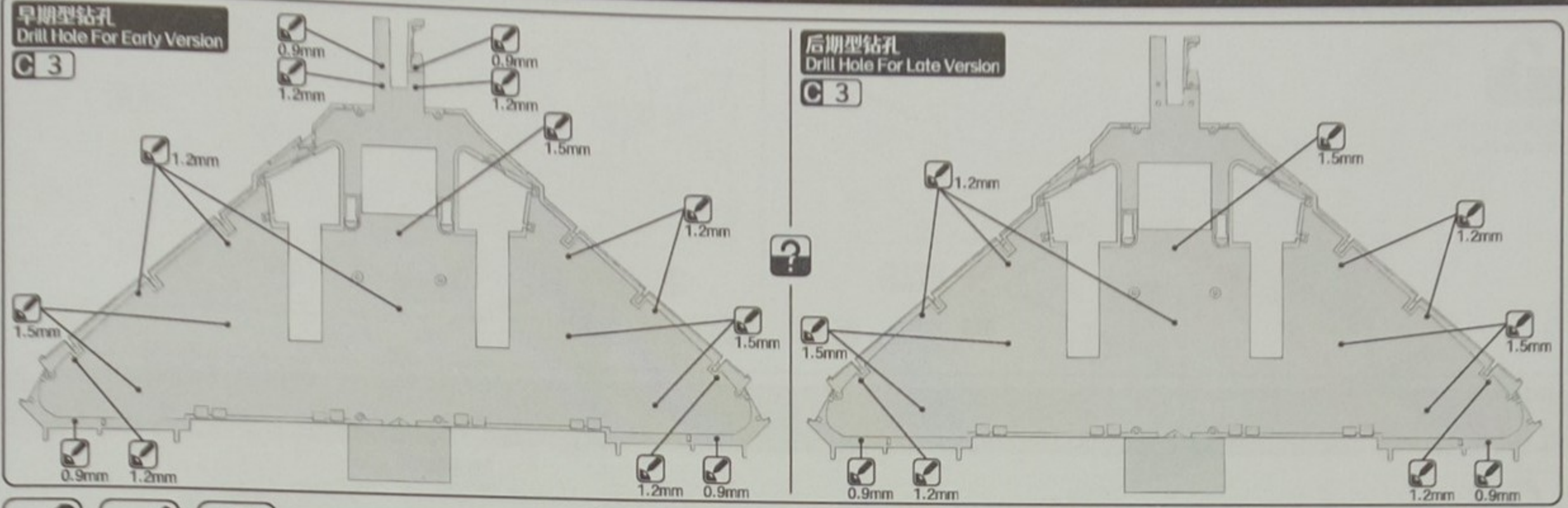

9. 机炮组合 Cannon Assembly



选择其一
Choose one

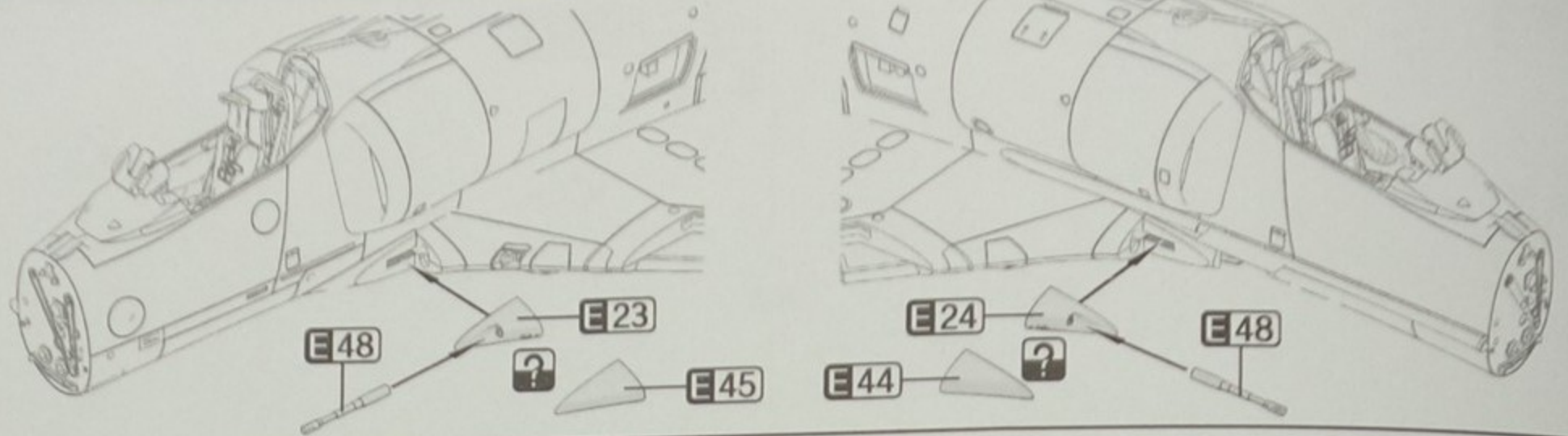

10. 尾喷管及前缘缝翼组装与组合 Jet Pipe Exhaust Nozzle And Slats Assembly

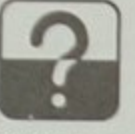

选择其一
Choose one

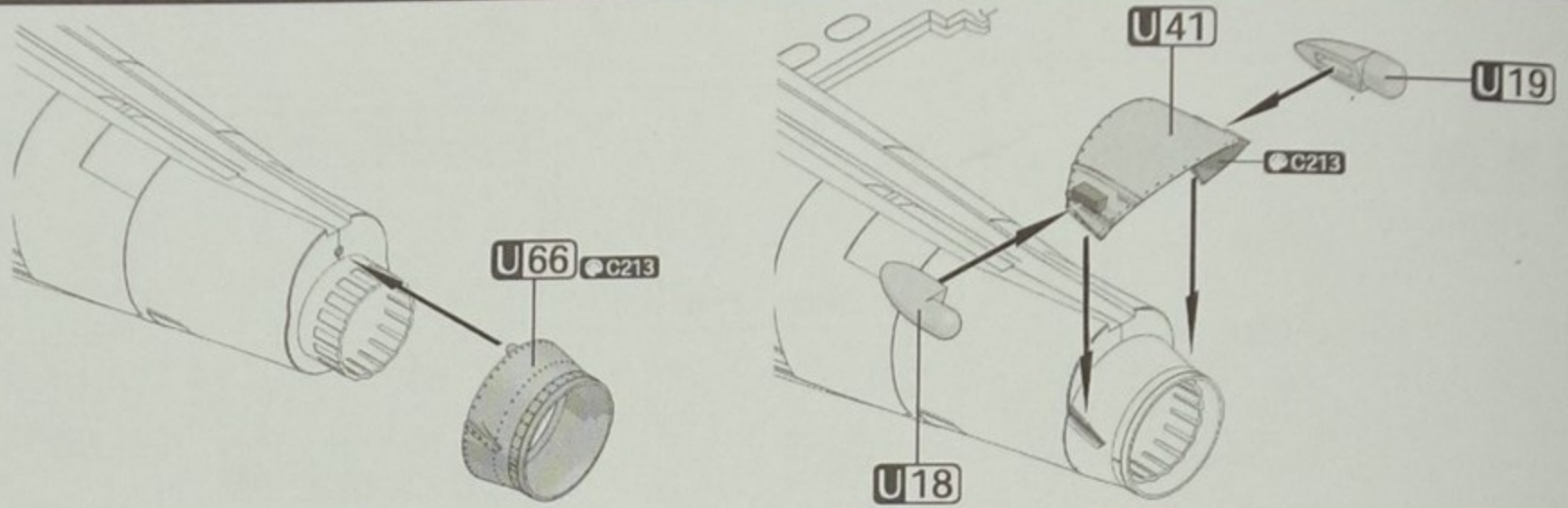

关闭状态选装
Slats Retracted

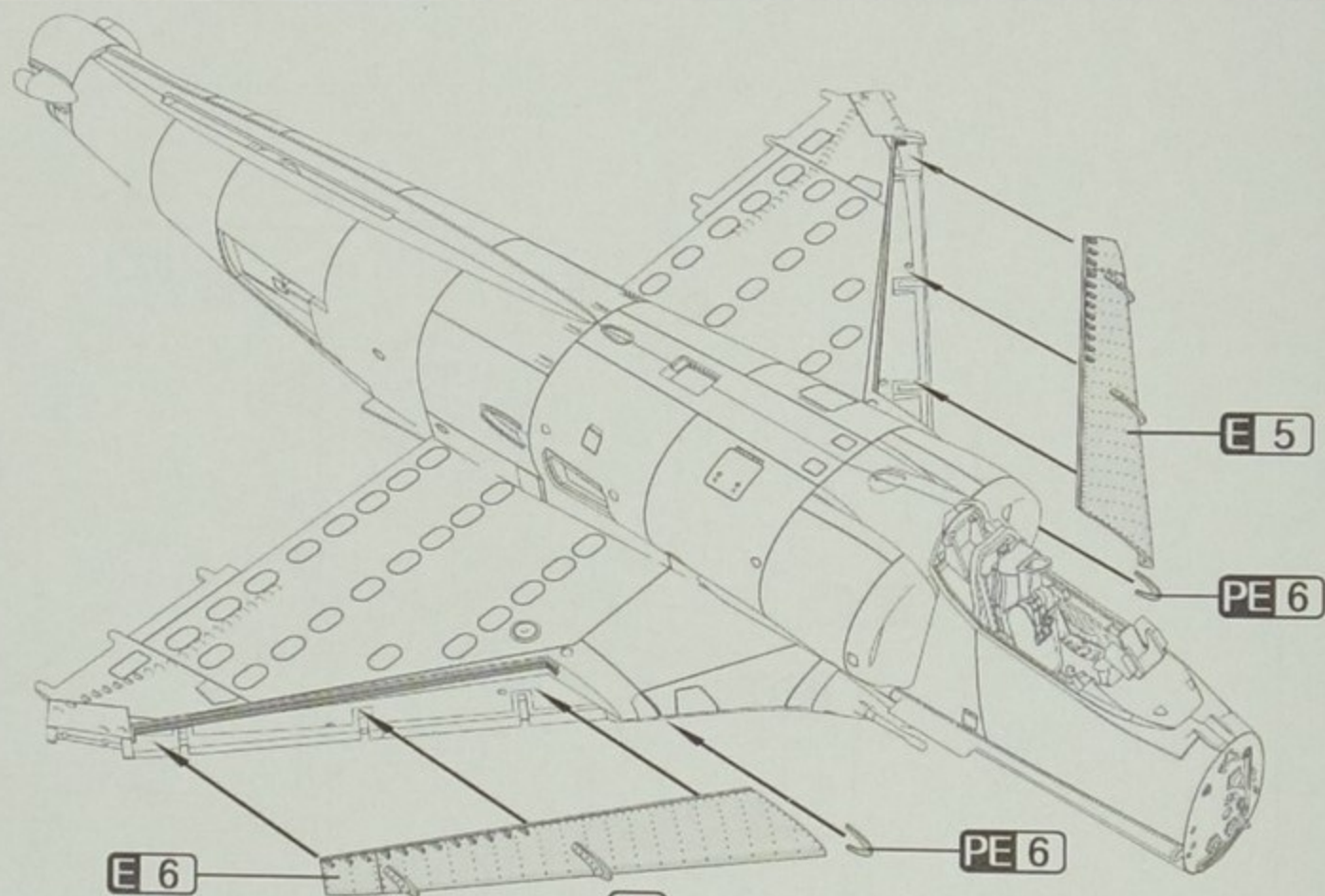

打开状态选装
Slats Deployed

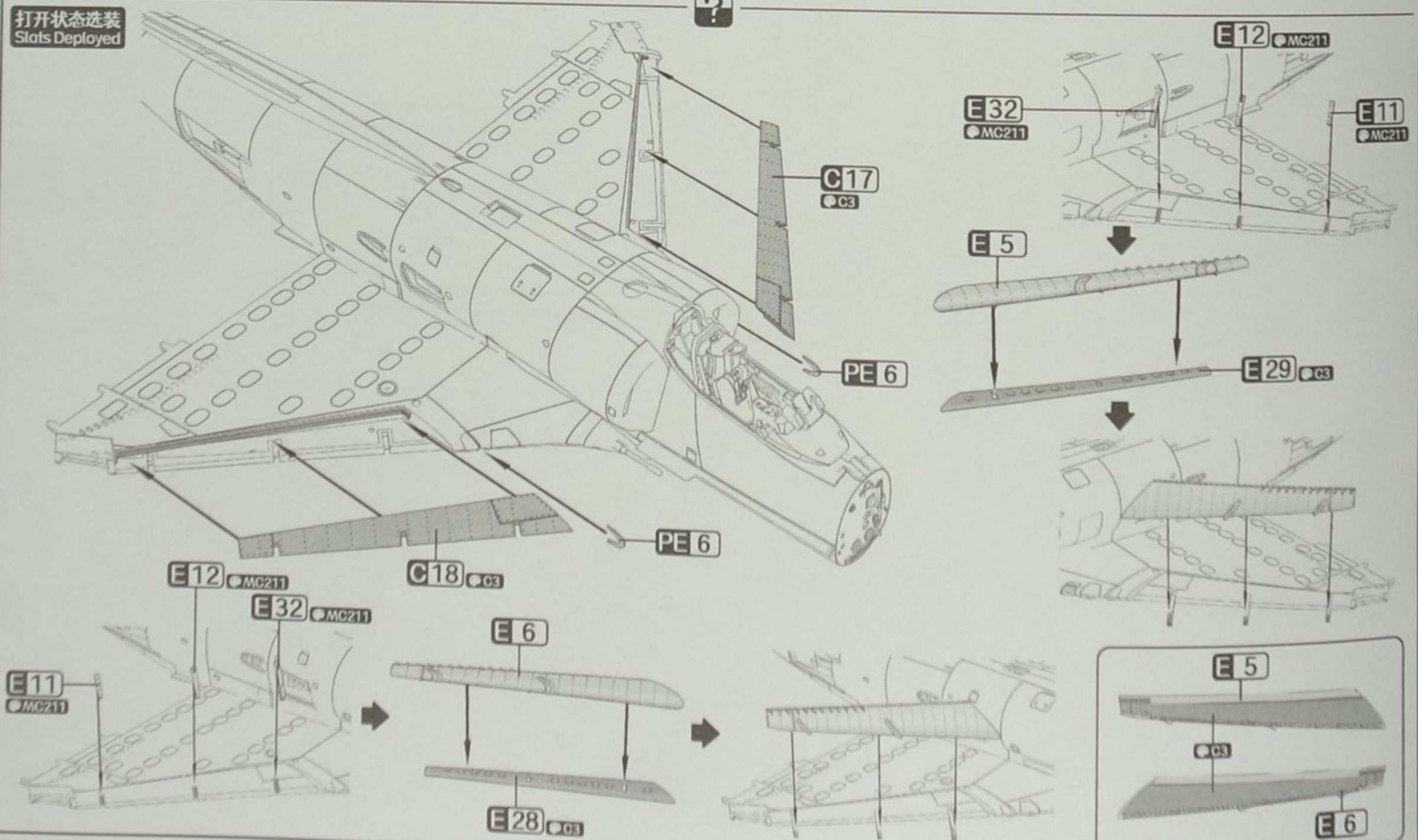

11. 水平尾翼组合 Elevators Assembly

需要切除
Cut

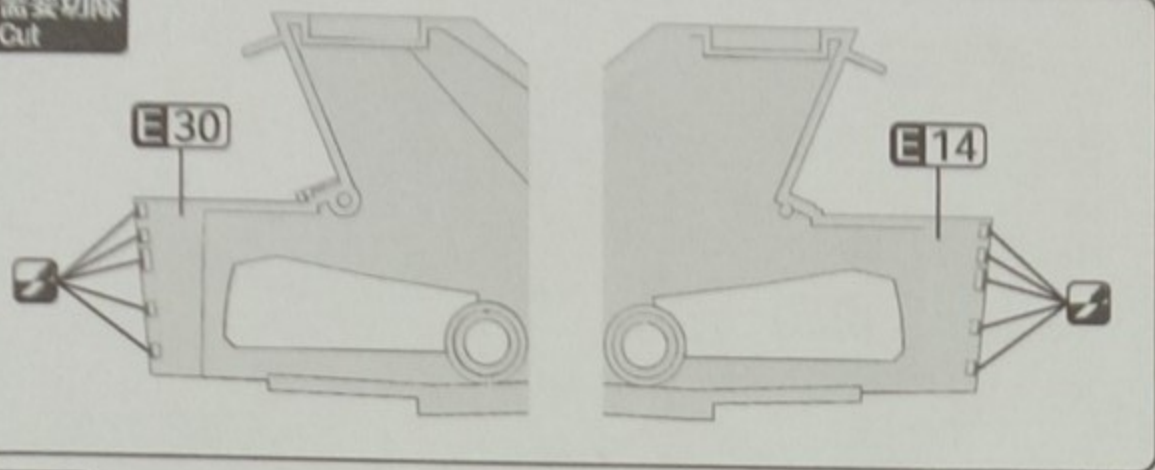

切除
Cut

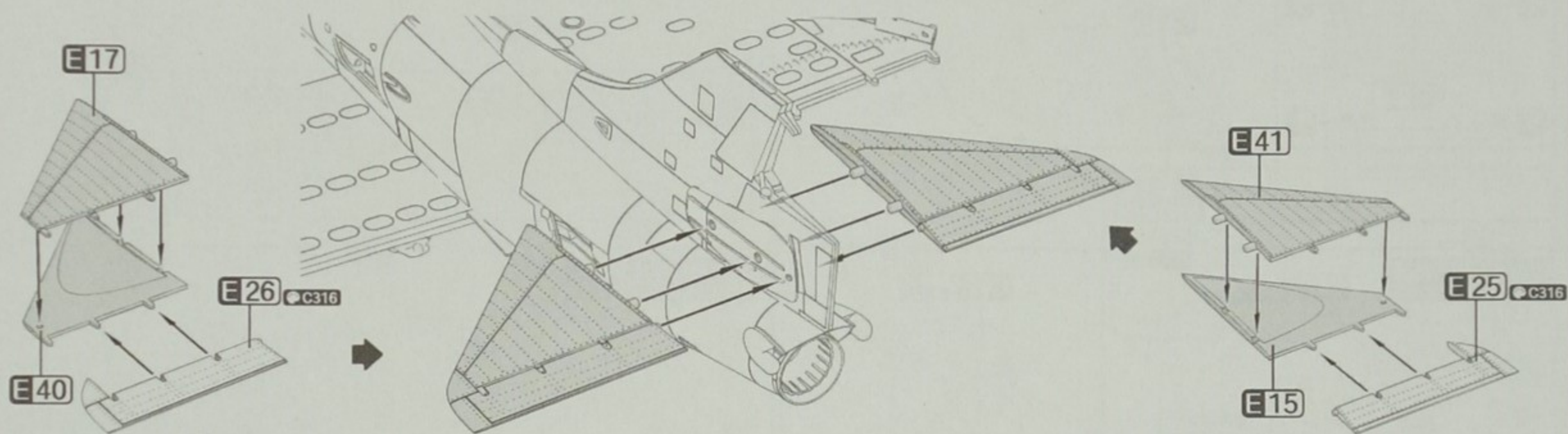
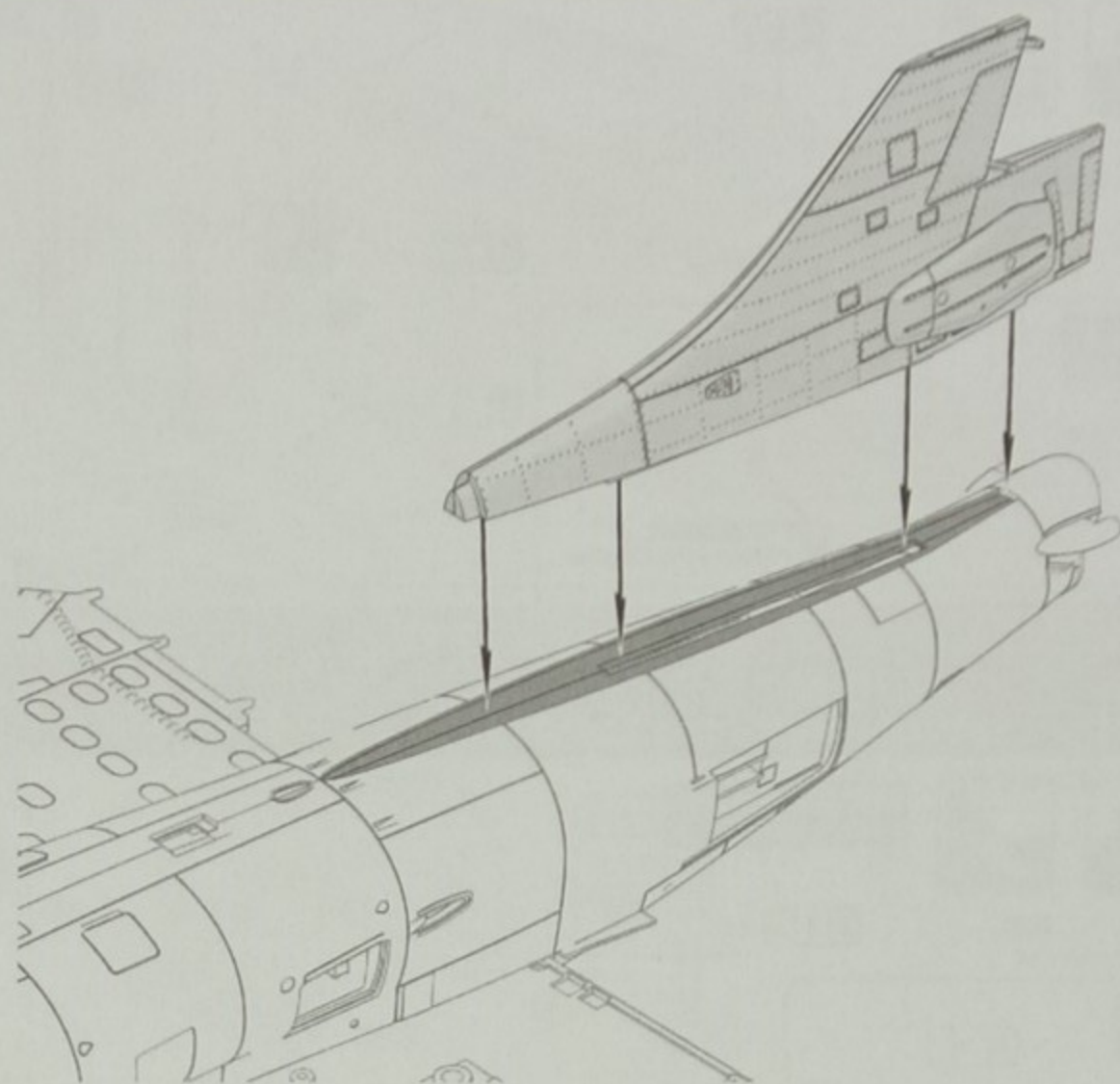
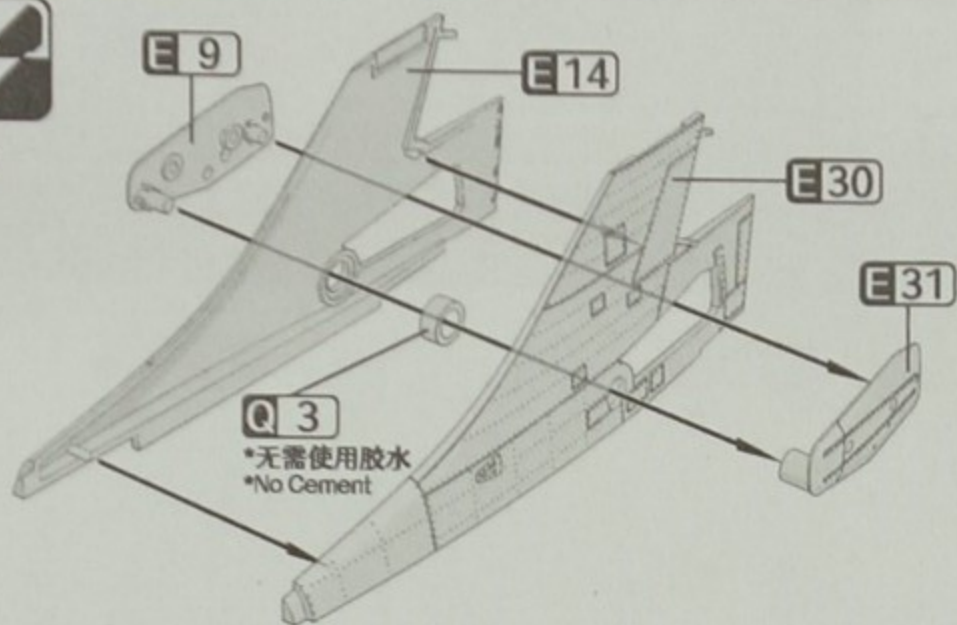

12. 垂直尾翼组合 Rudder Assembly

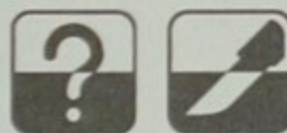

选择其一 切除
Choose one Cut

早期型选装
Early Version Option

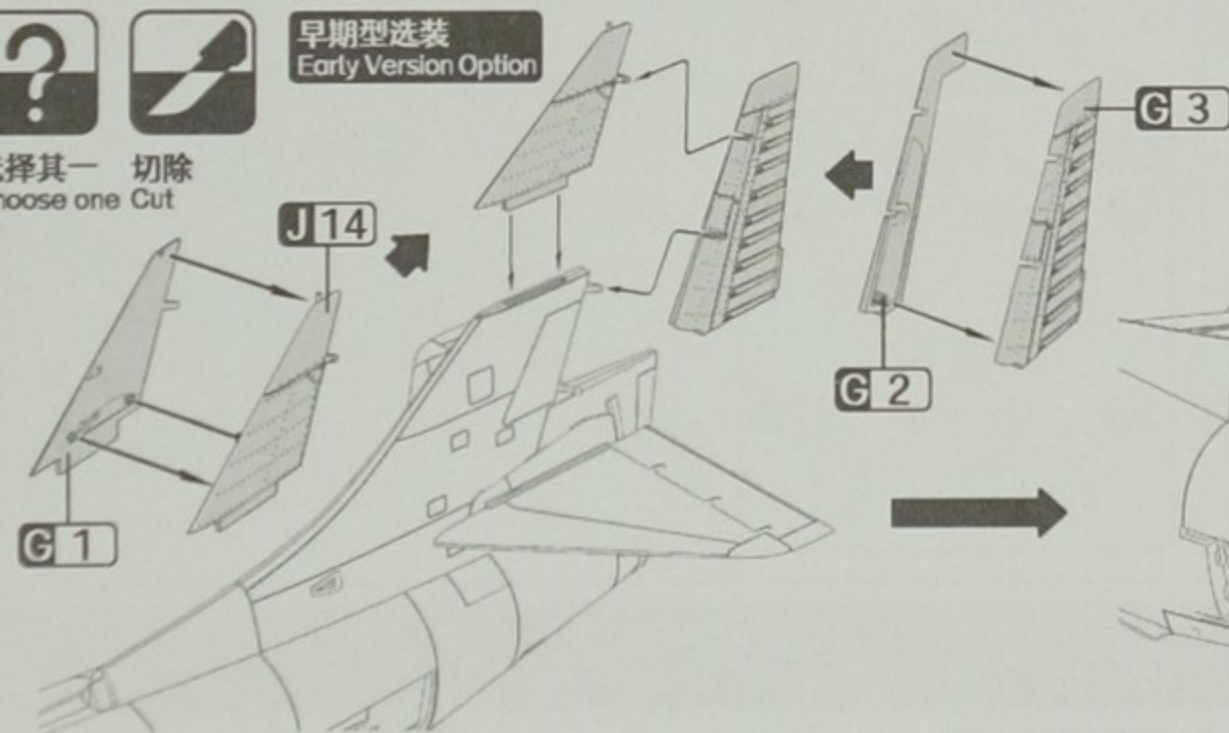

*注意零件安装方向与位置
*Note part assembly direction & position

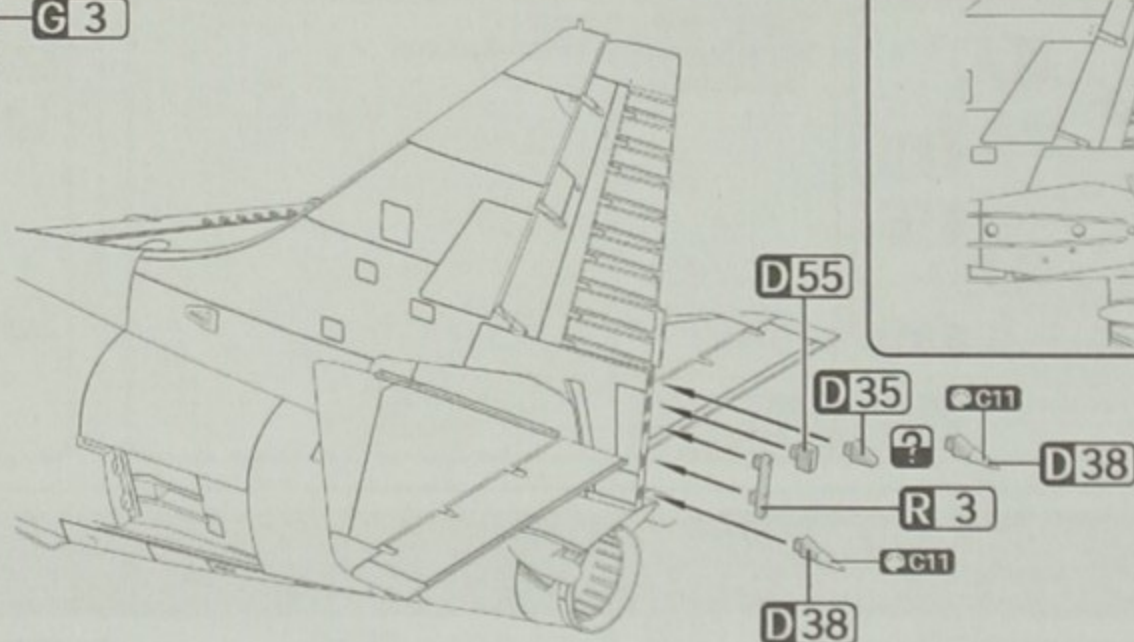
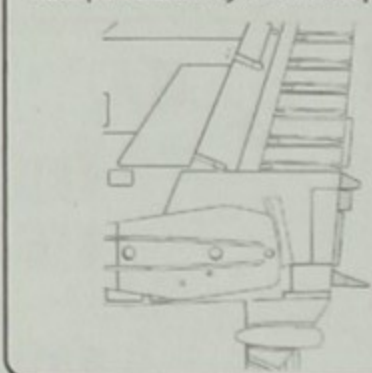

后期型选装
Late Version Option

需要切除
Cut

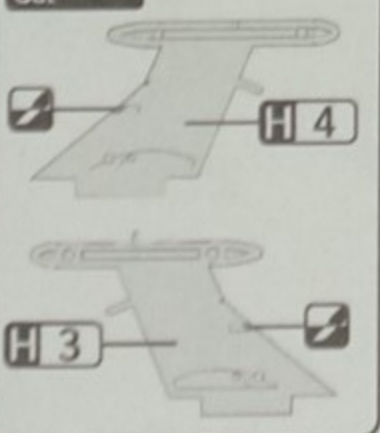

金属空簧管
Metal Pilot Tube

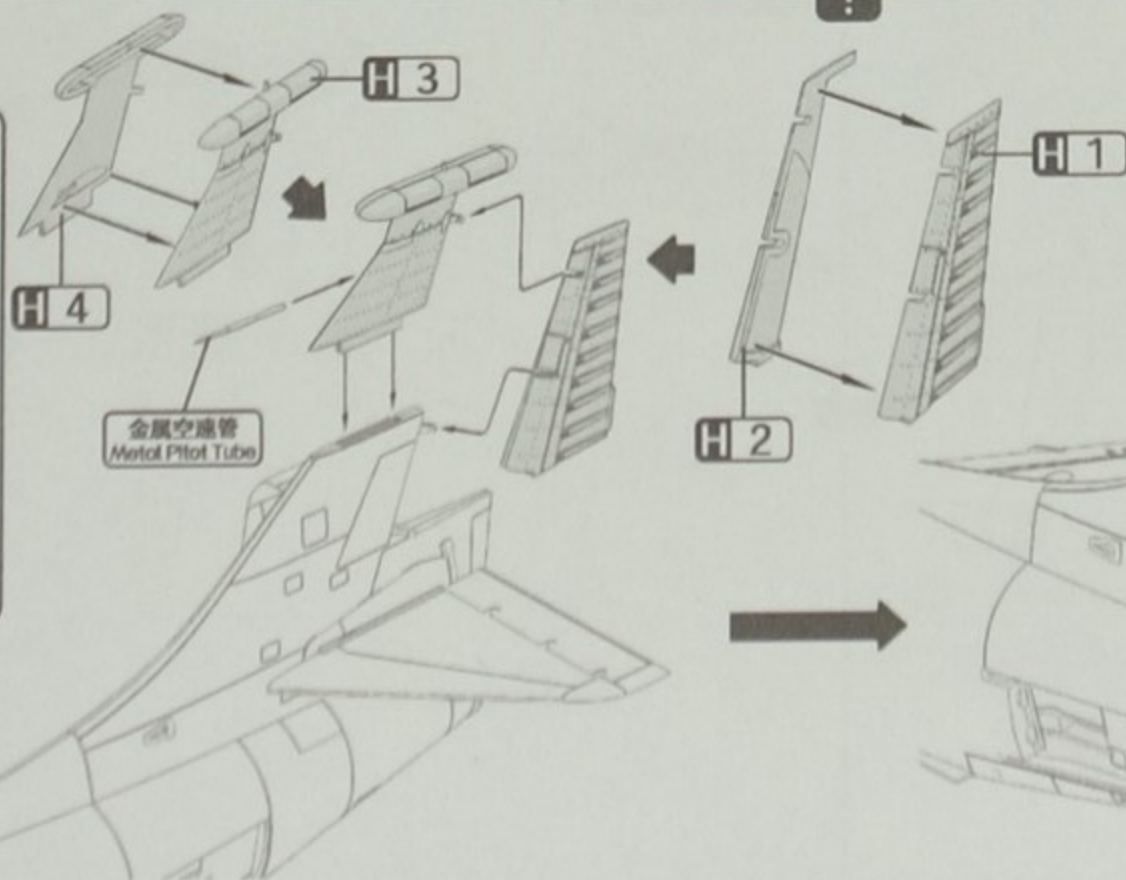

*注意零件安装方向与位置
*Note part assembly direction & position

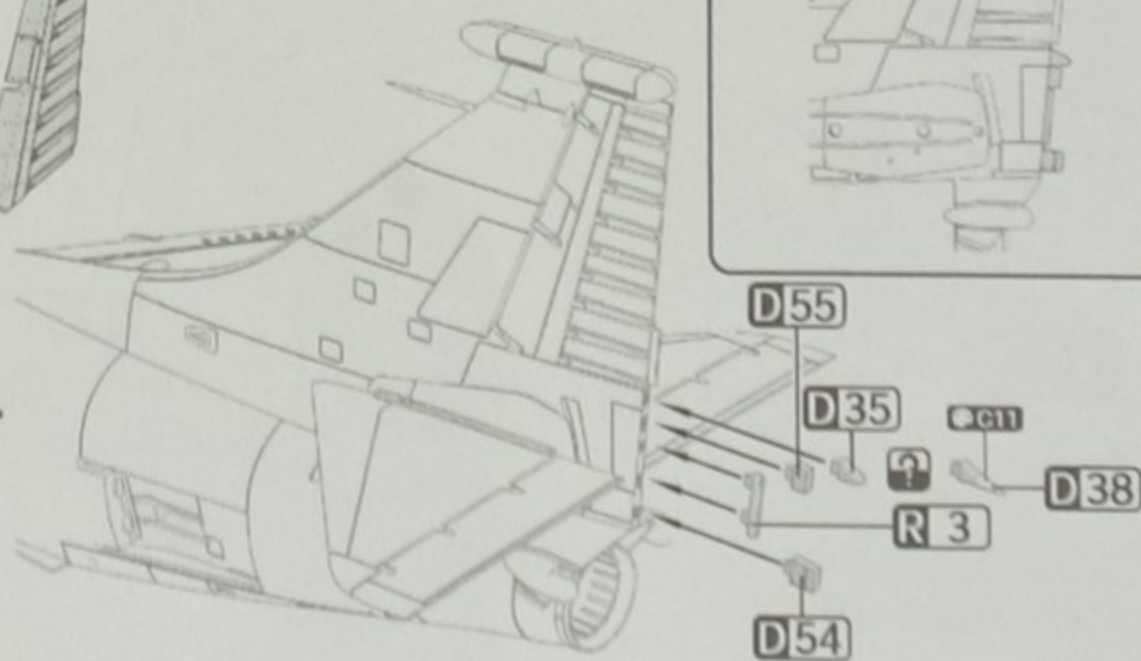
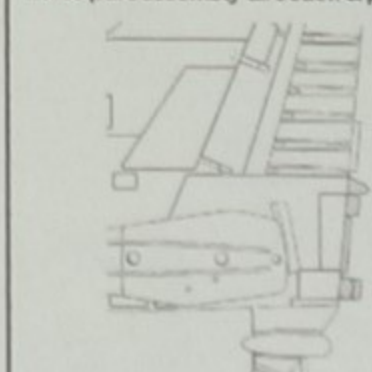

13. 机背电子舱组装与组合 Upper Avionics Package

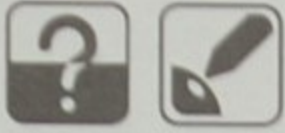

选择其一 钻孔
Choose one Drill hole

需要钻孔
Drill Hole

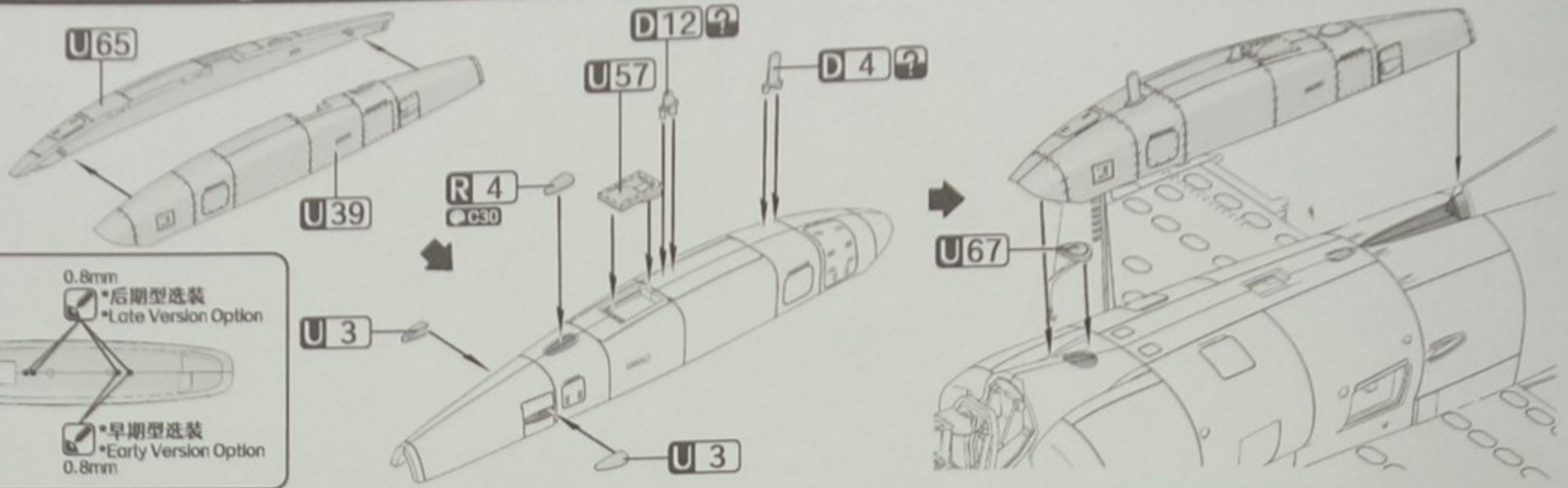
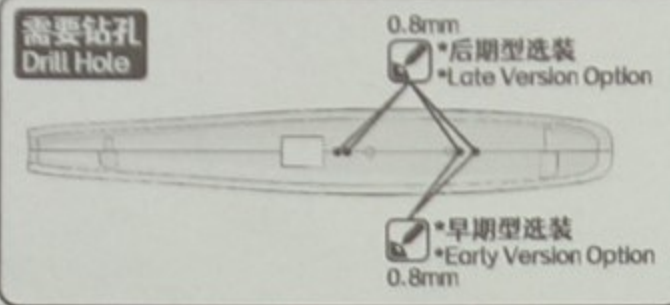

14. 扰流板/襟翼组装及组合 Spoilers And Flaps Assembly

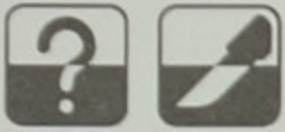

选择其一 切除
Choose one Cut

切除
Cut

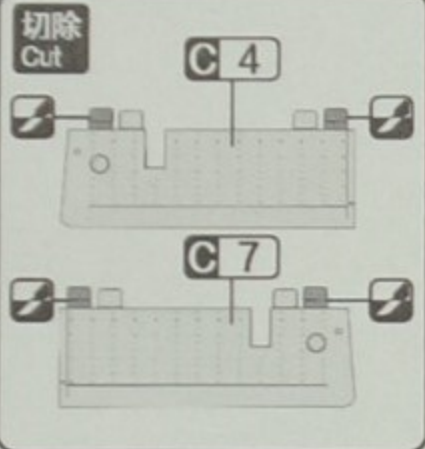

襟翼收起状态选装
Flaps Up Status

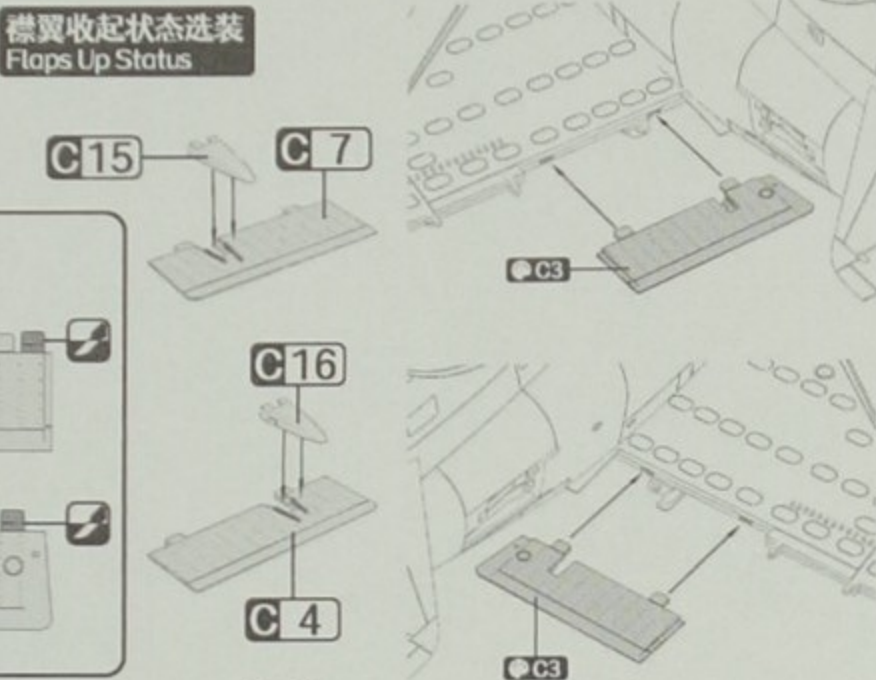

扰流板关闭状态选装
Spoilers Closed Status

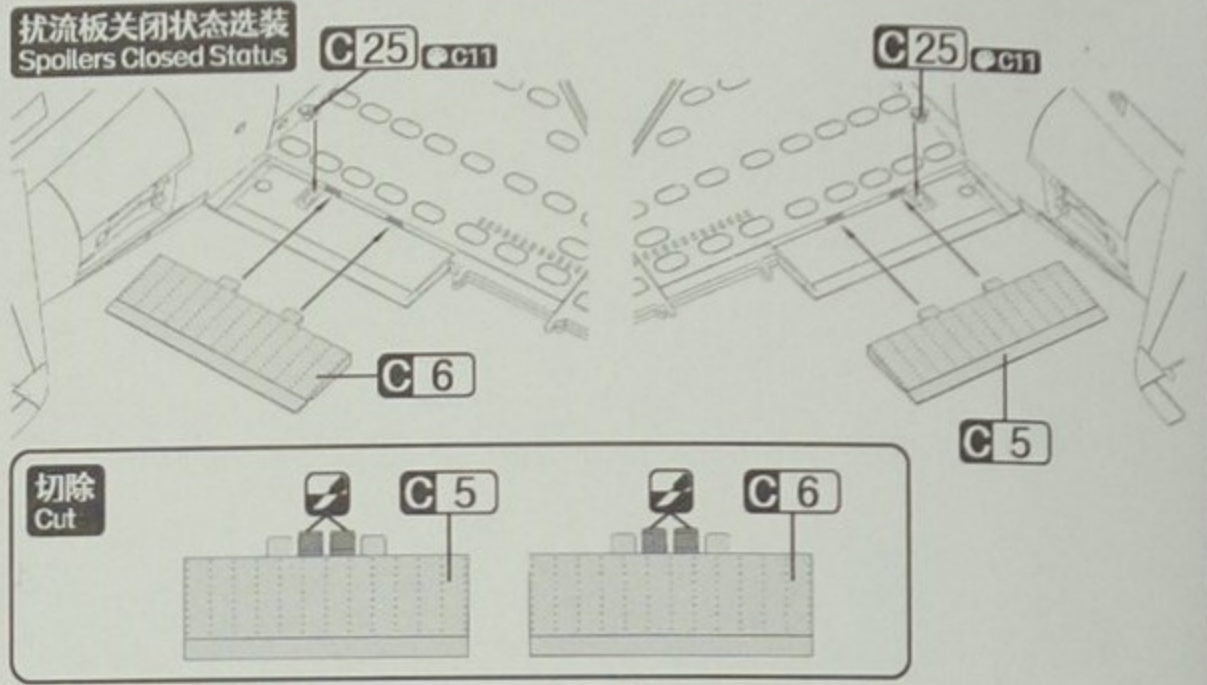

襟翼放下状态选装
Flaps Down Status

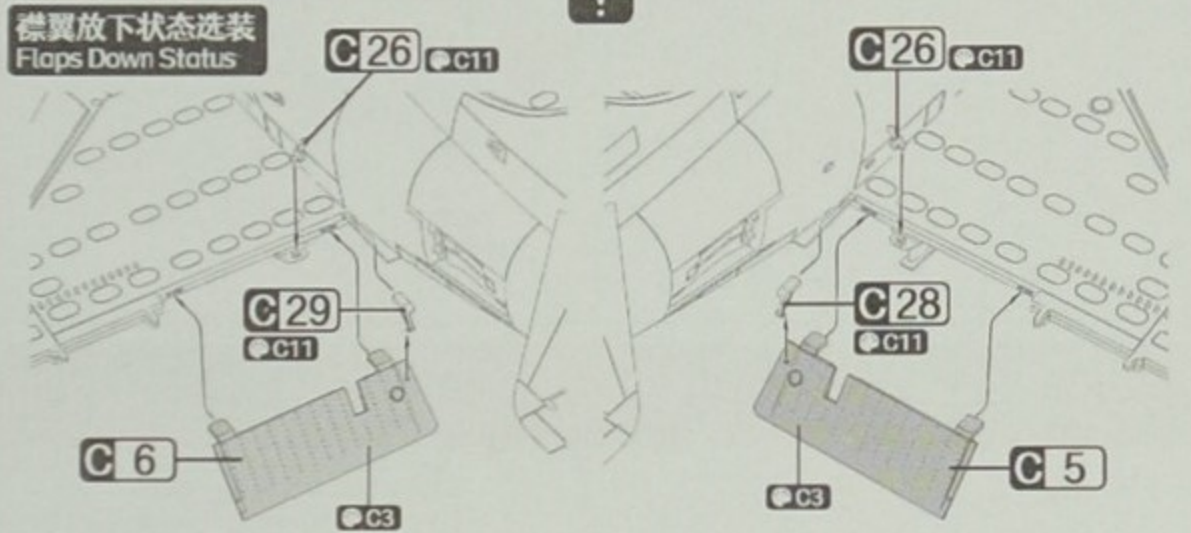

扰流板打开状态选装
Spoilers Opened Status

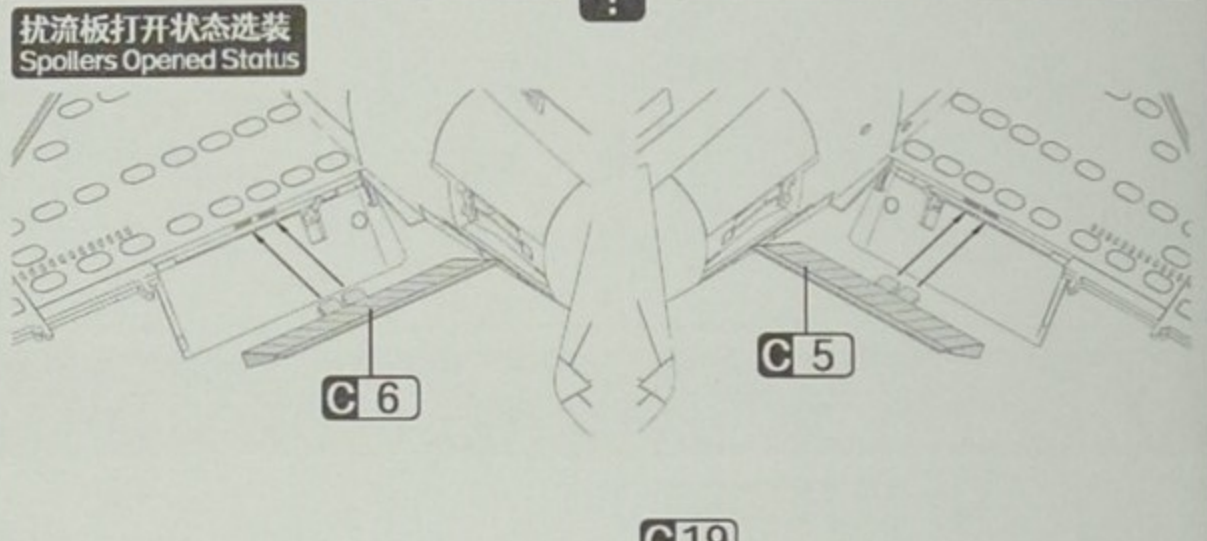

切除
Cut

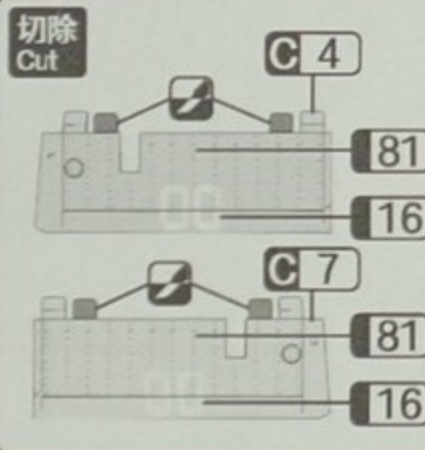

*注意零件安装方向与位置
*Note part assembly direction & position

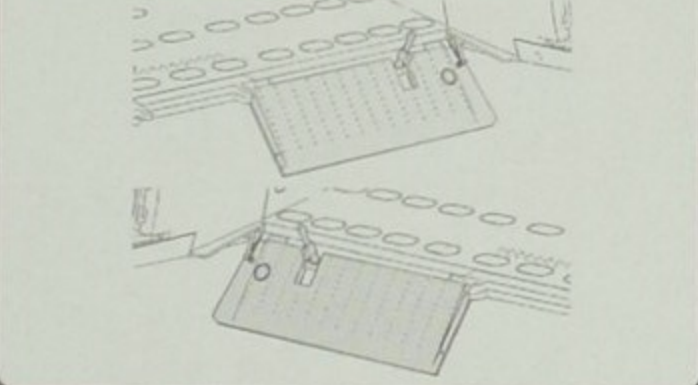

切除
Cut

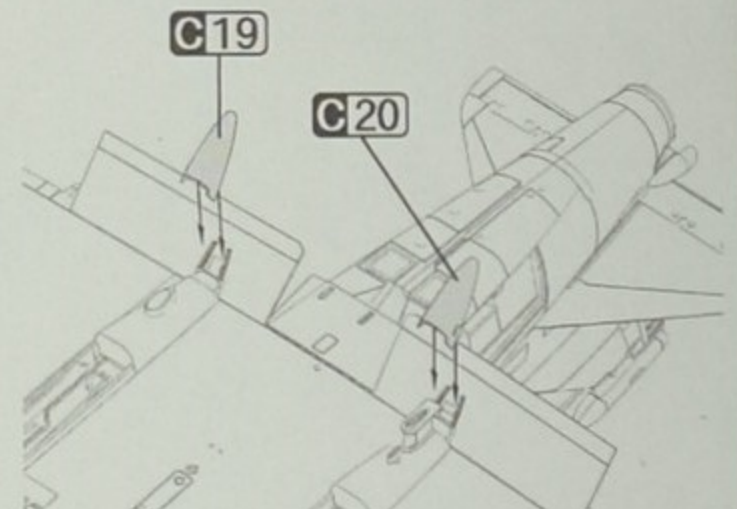
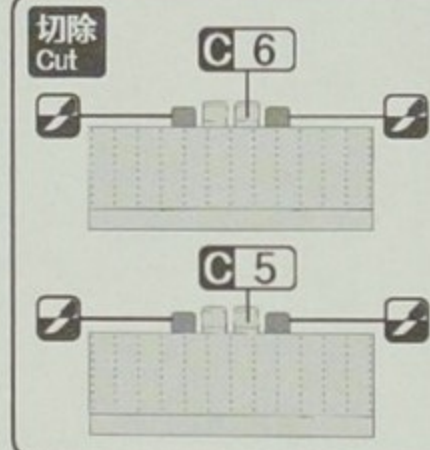

15. 副翼组装与组合 Aileron Assembly



选择其一
Choose one

平直状态选装
Aileron Neutral

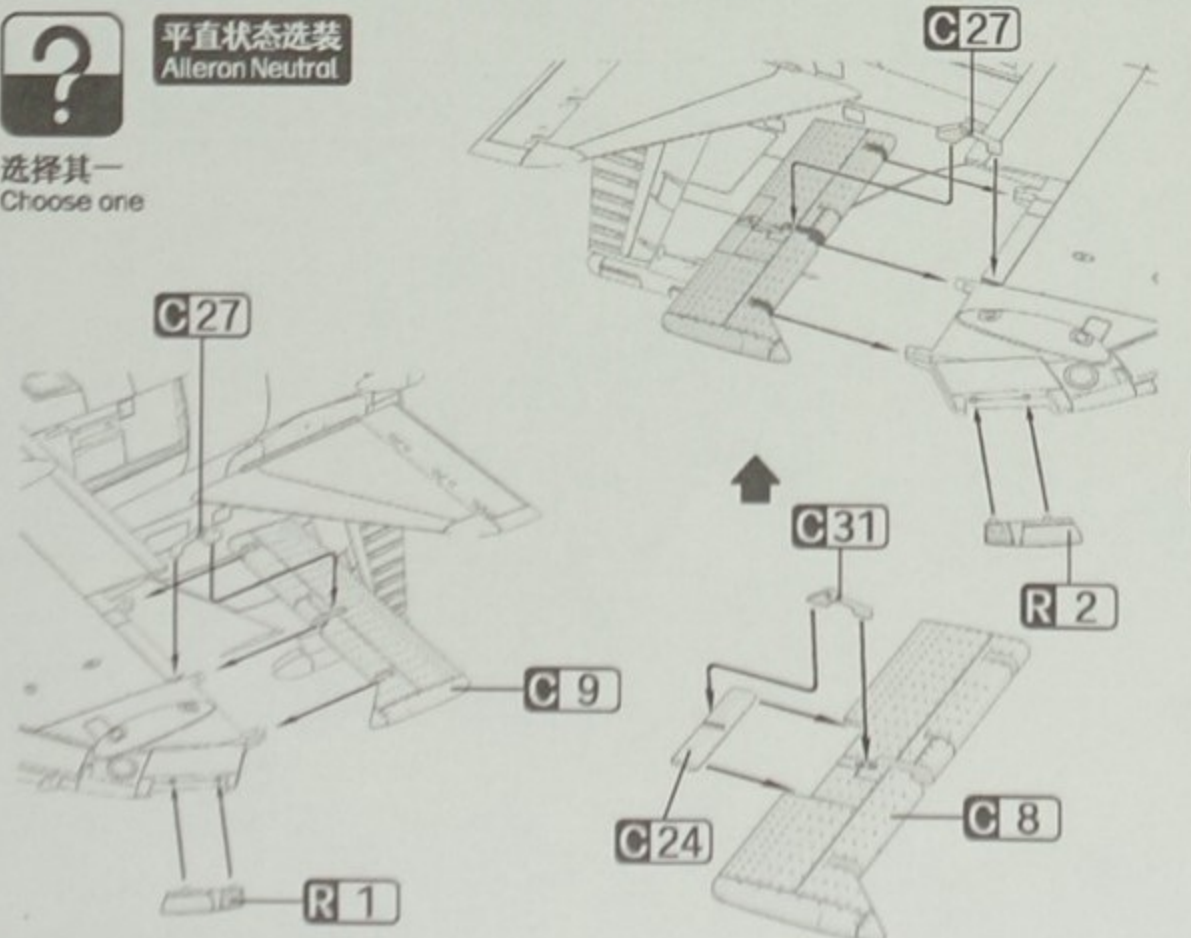

翻折状态选装
Aileron Deflected

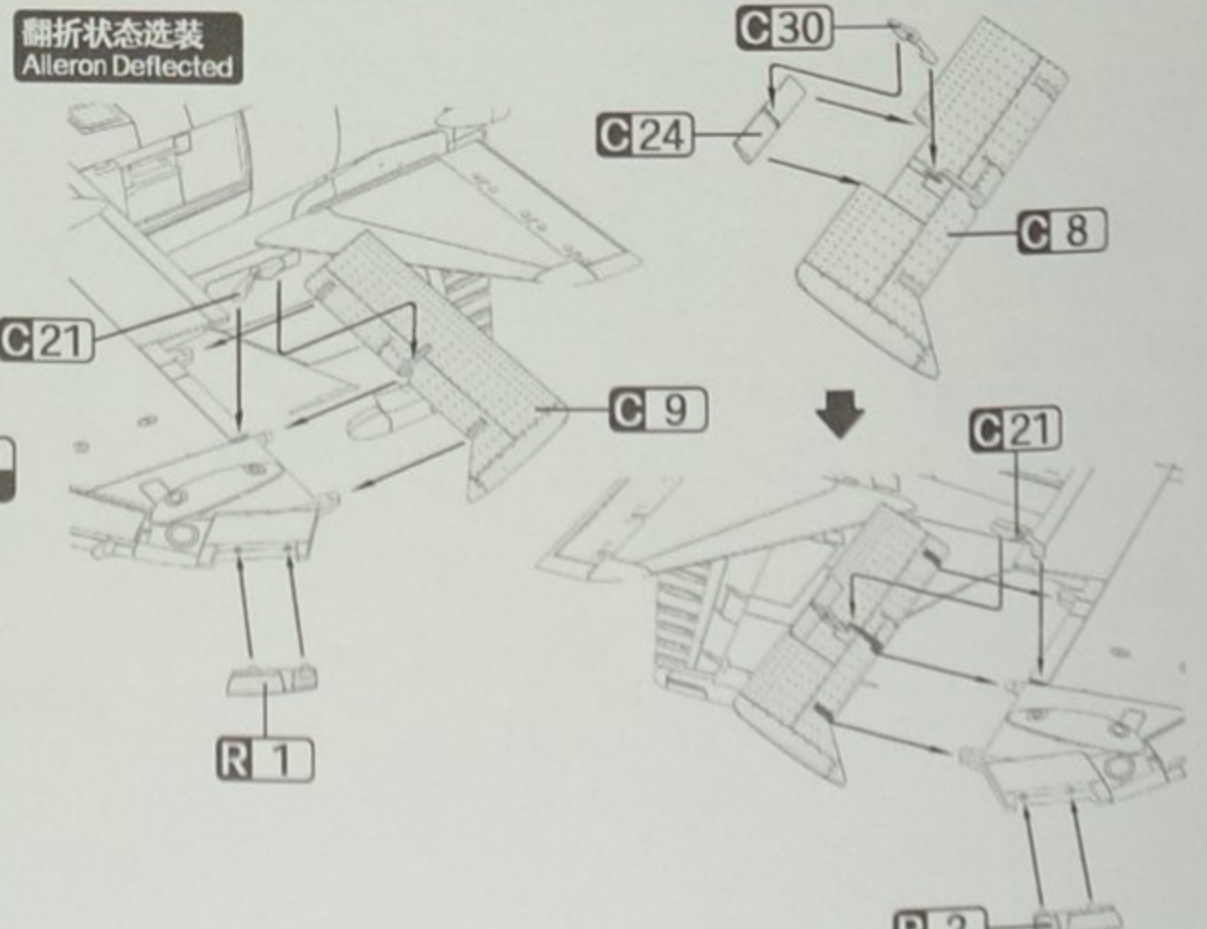

16. 着陆钩组装与组合 Tailhook Assembly



优先制作
Assemble first

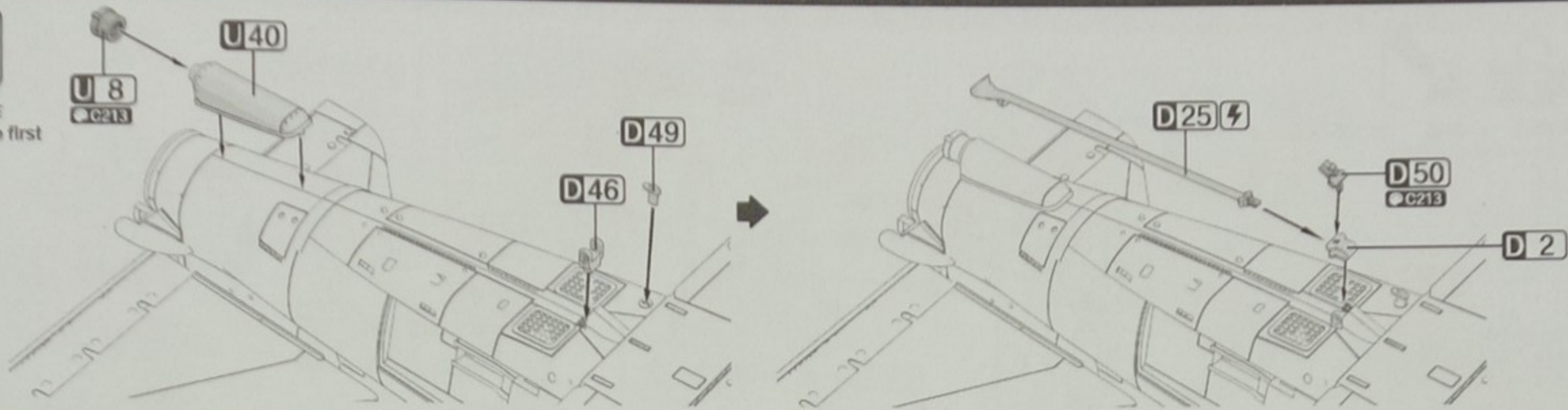

17. 起落架安装 Landing Gear Assembly

RAT关闭状态选装
RAT Closed Option

RAT打开状态选装
RAT Opened Option

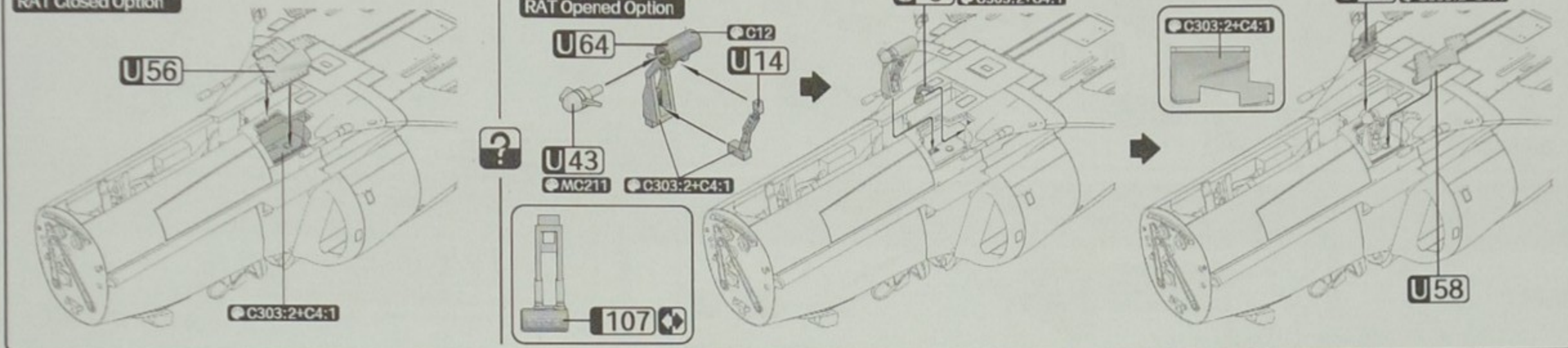

选择其一 对称制作
Choose one Both sides

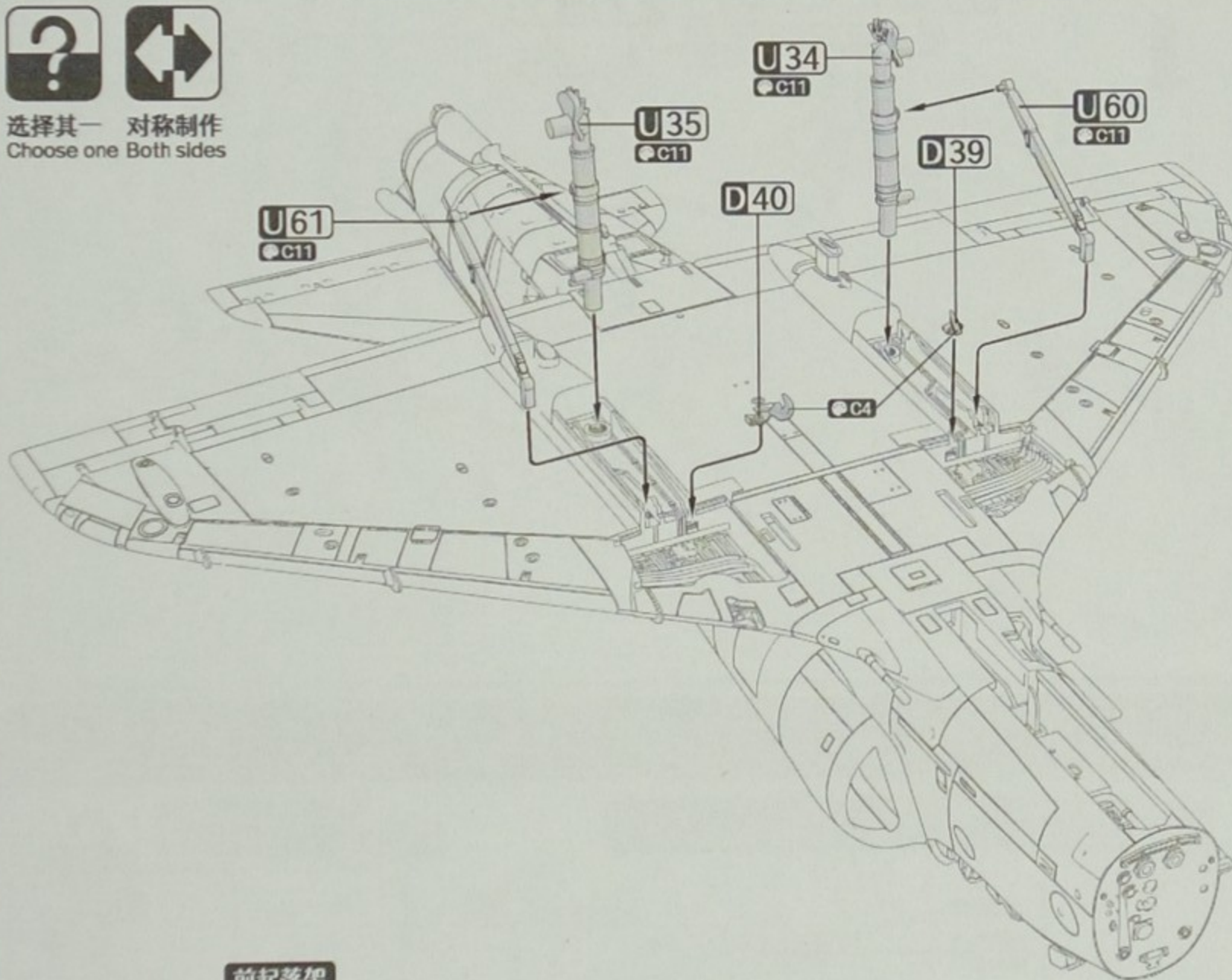

前起落架
Nose Gear

PE 5

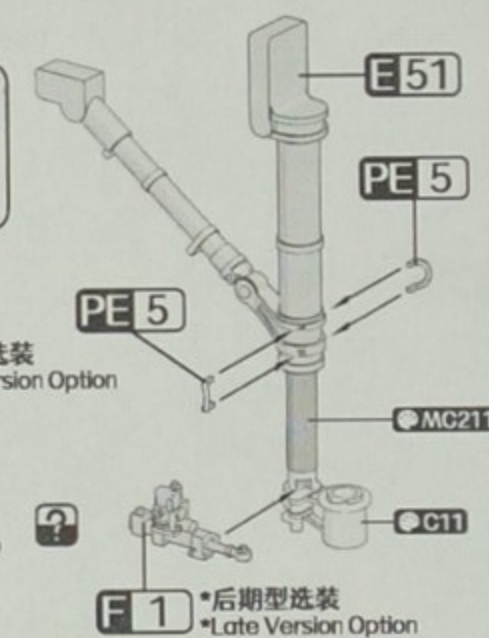

前起落架轮
Front Wheel

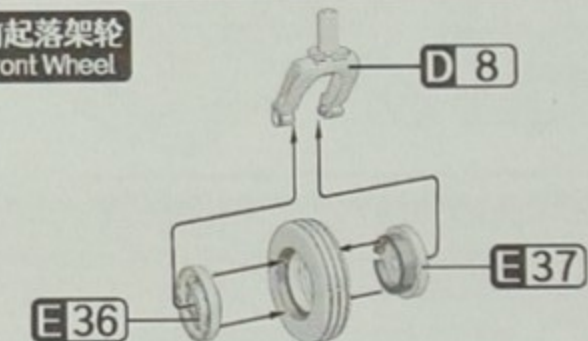

主起落架轮
Main Landing Gear Wheel

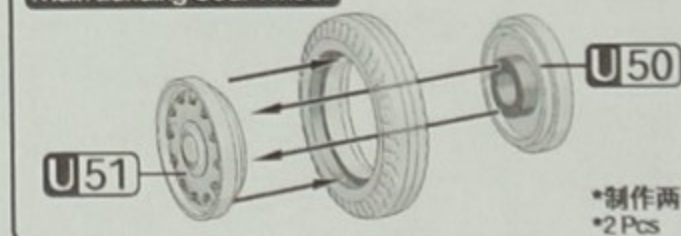

前起落架
Nose Gear

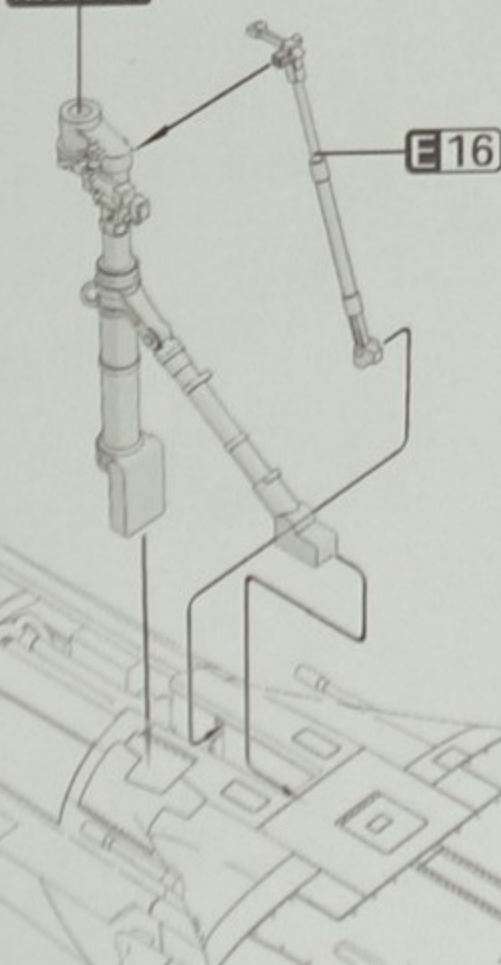

主起落架轮
Main Landing Gear Wheel

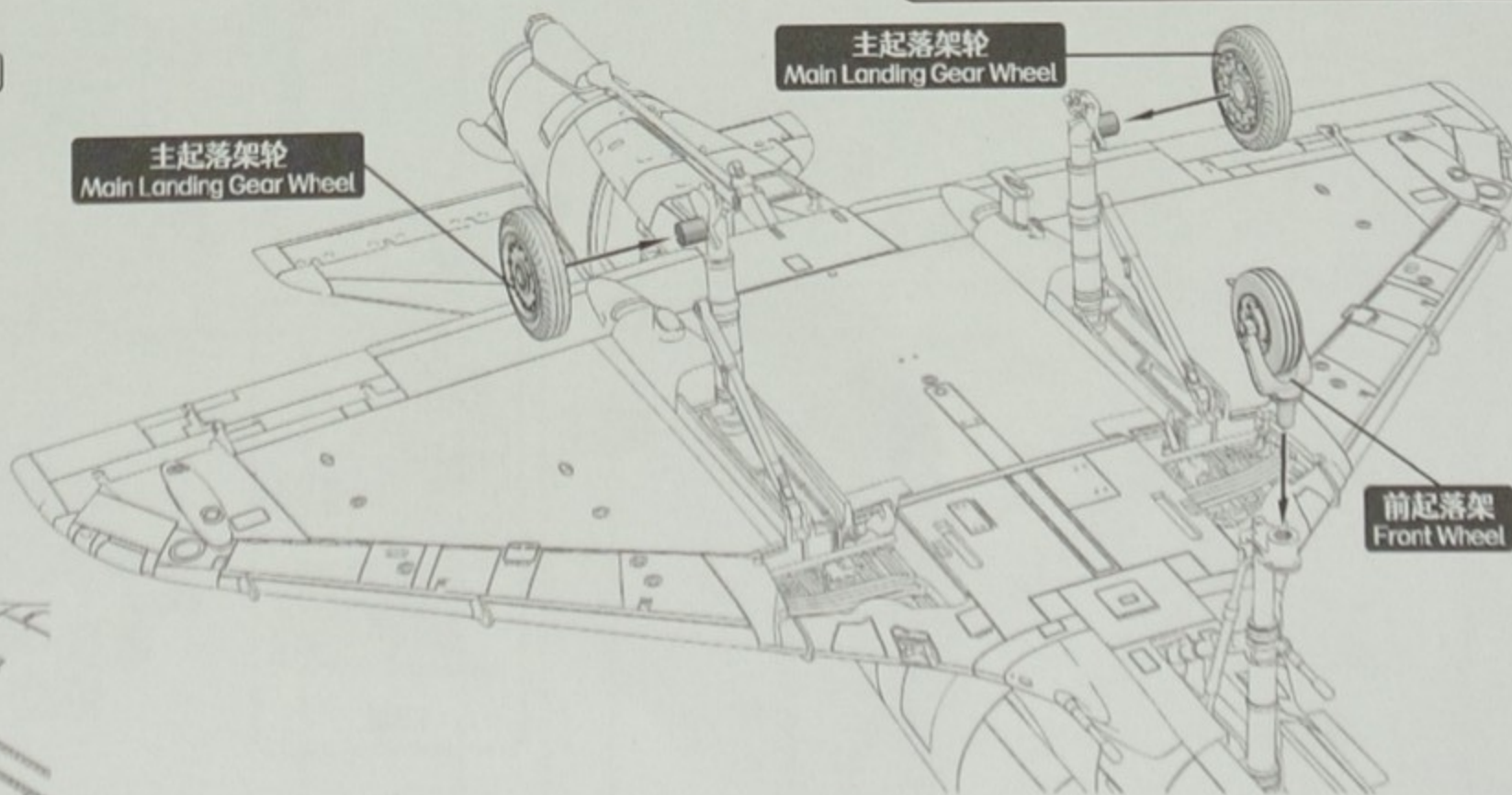

主起落架轮
Main Landing Gear Wheel

前起落架
Front Wheel

18. 起落架舱盖组装 Main Landing Gear Door Assembly

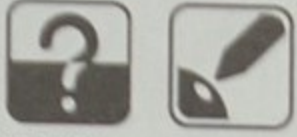

选择其一 钻孔
Choose one Drill hole

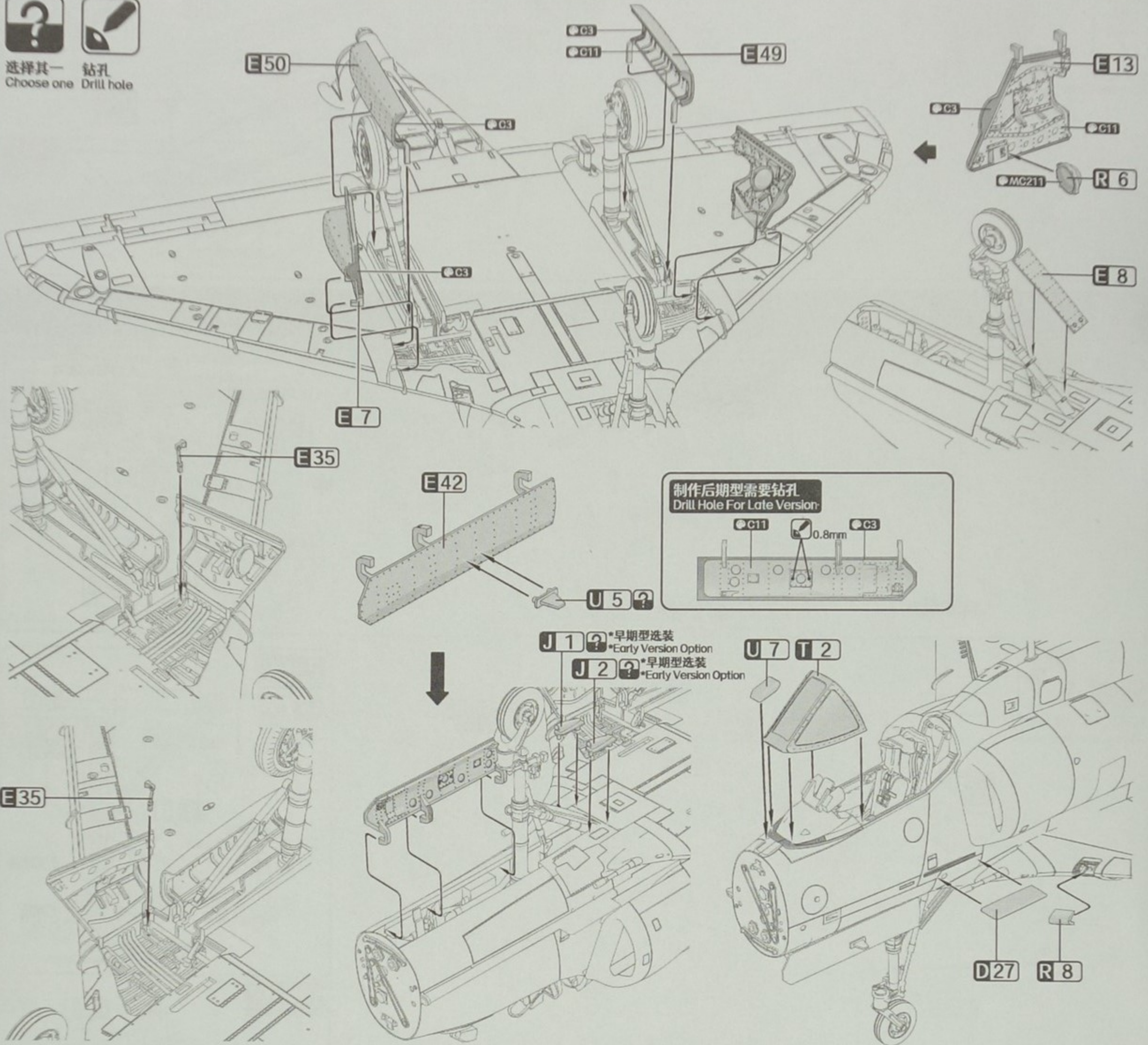

19. 发动机检修口与减速板组合 Engine Access Door and Speedbrake Assembly



关闭状态选装
Engine Access Door and Speedbrake Closed

选择其一
Choose one

打开状态选装
Engine Access Door and Speedbrake Opened

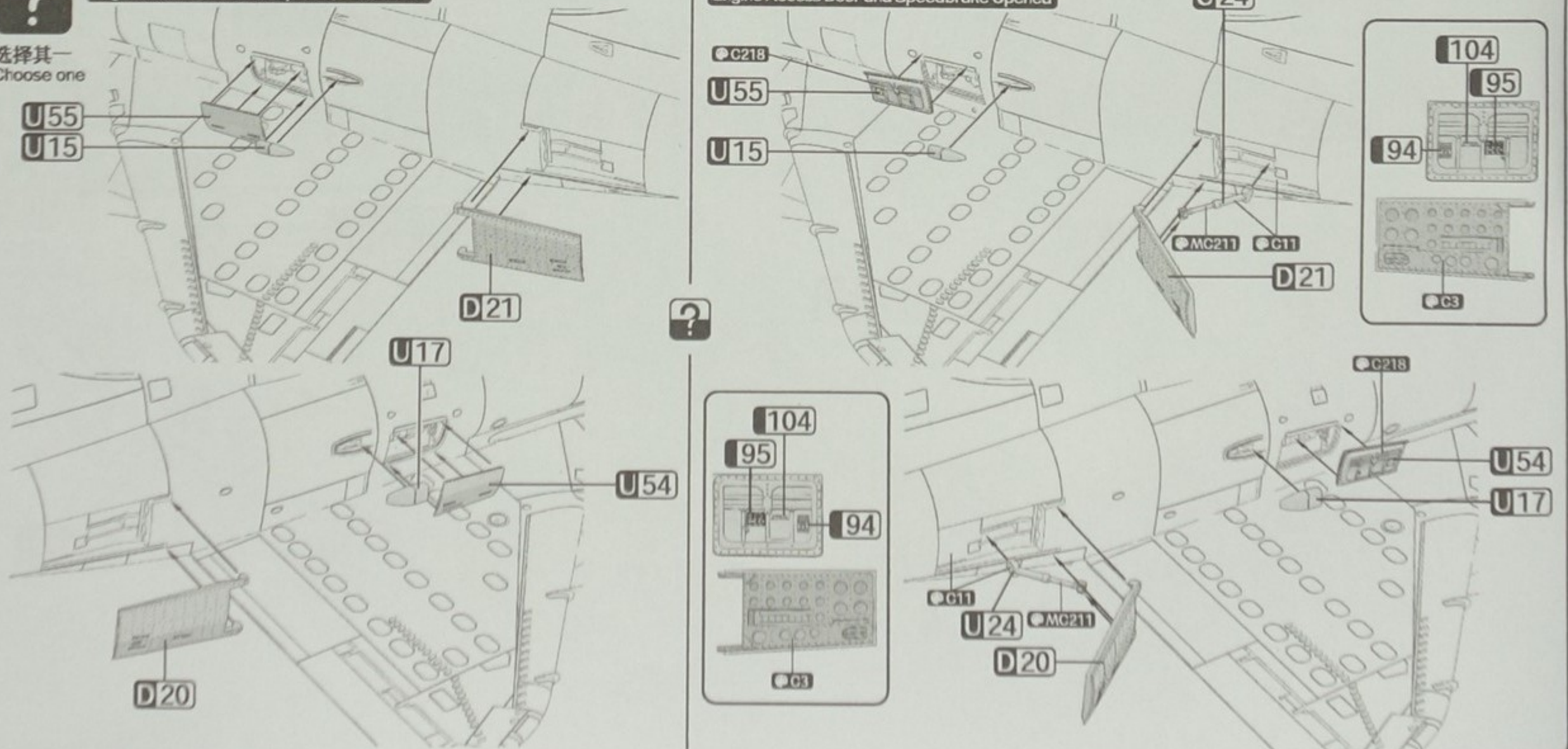

20. 机头电子舱组装与组合 Nose Sec. Elec. Equip. Compartment Assembly

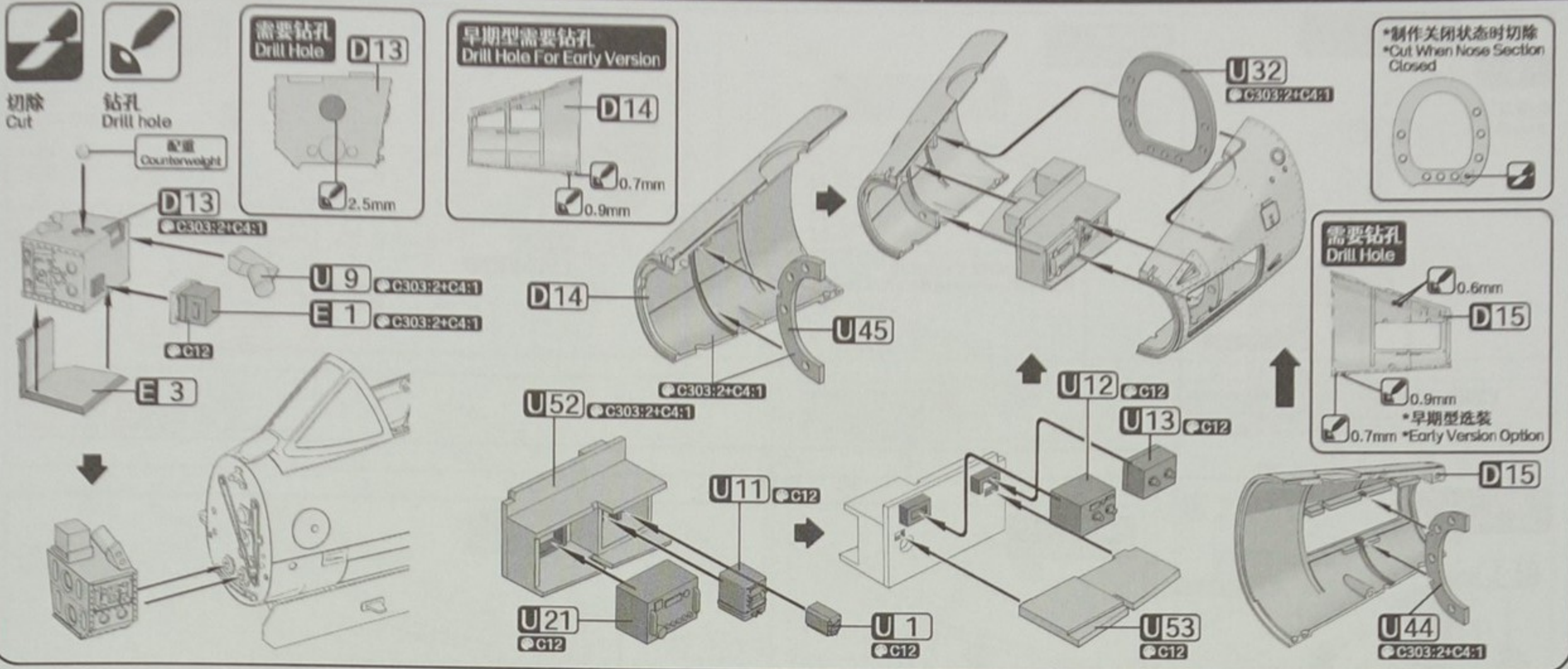

21. 电子舱舱门组合 Nose Section Doors Assembly

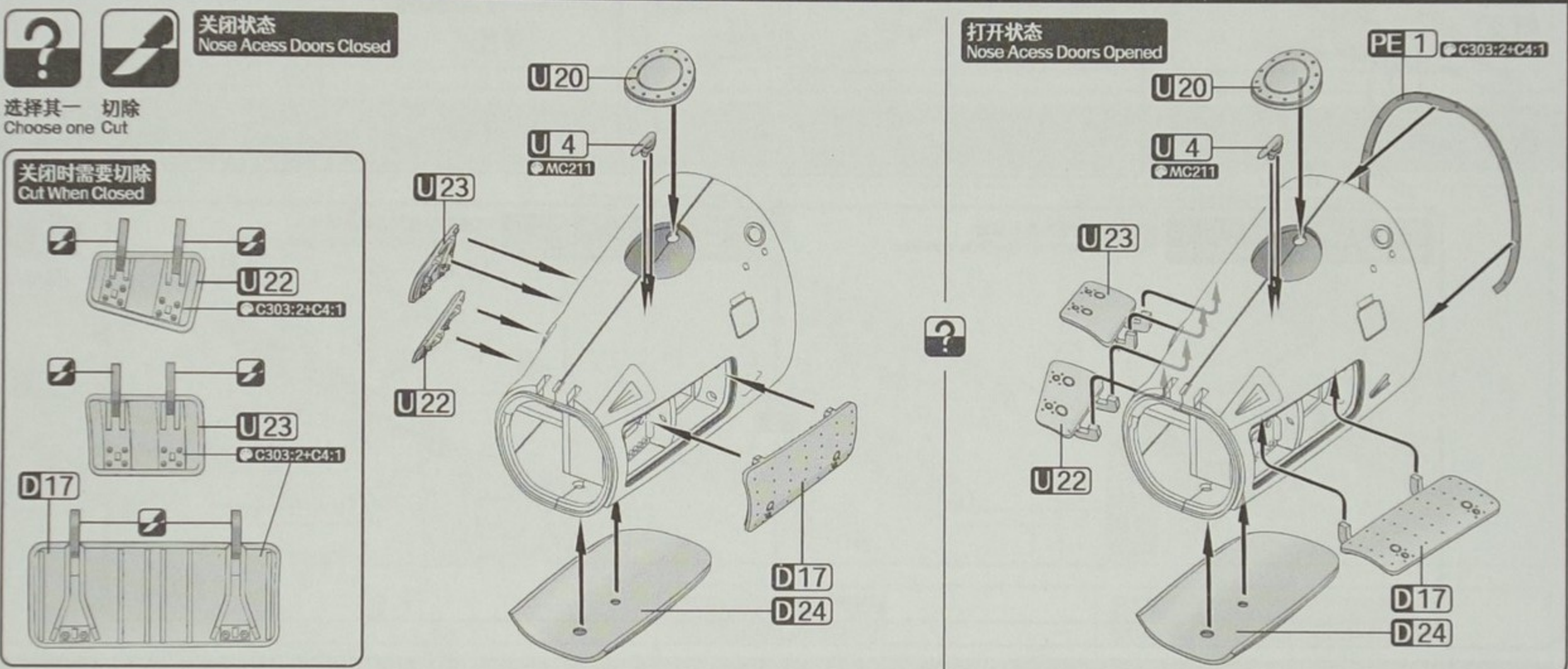

22. 机头组合 Nose Section Assembly

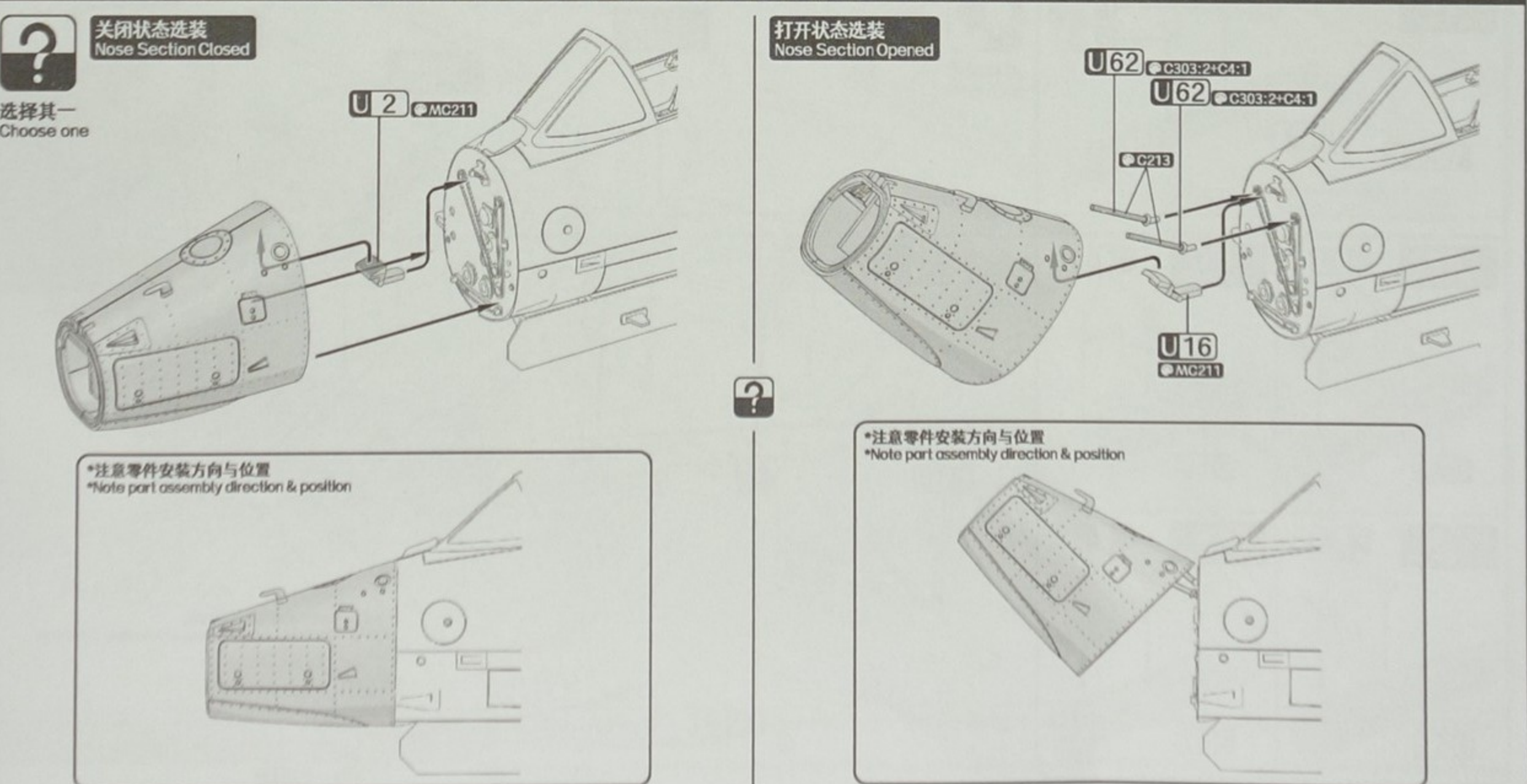

23. 机鼻安装 Radome Assembly



早期型
Early Version Option

选择其一
Choose one

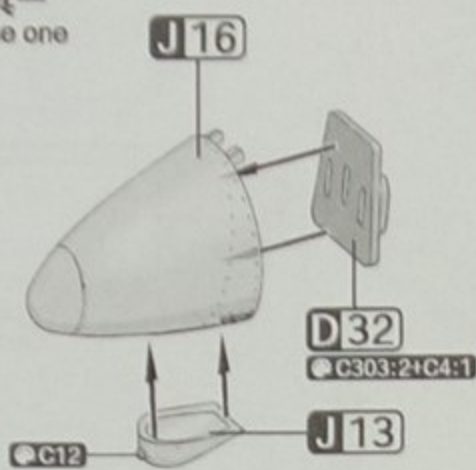

关闭状态
Radome Closed



打开状态
Radome Opened

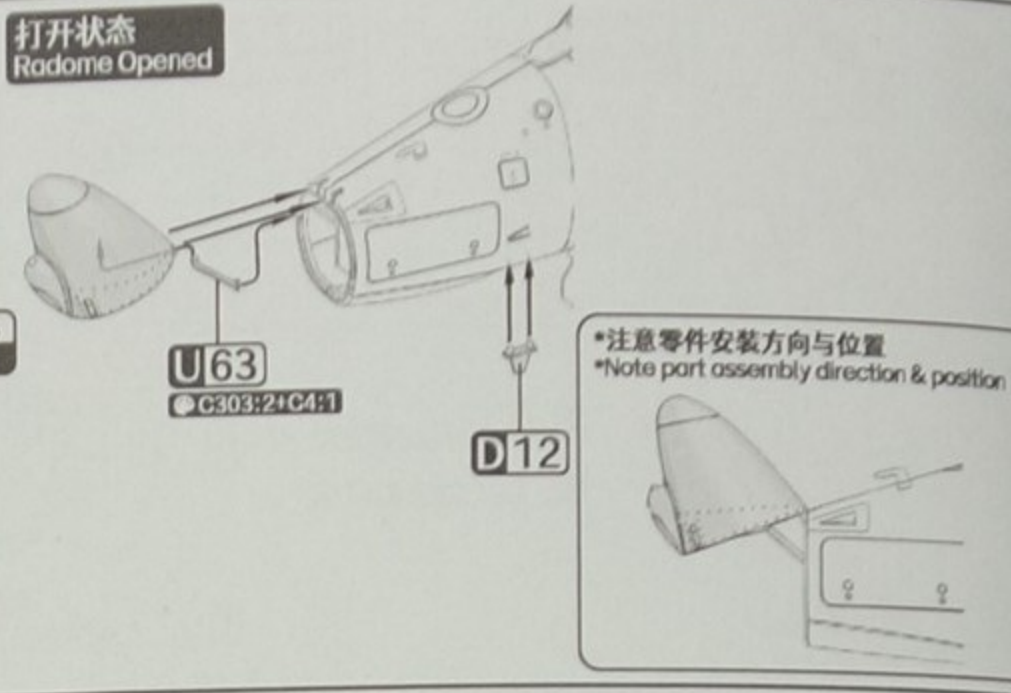

后期型
Late Version Option

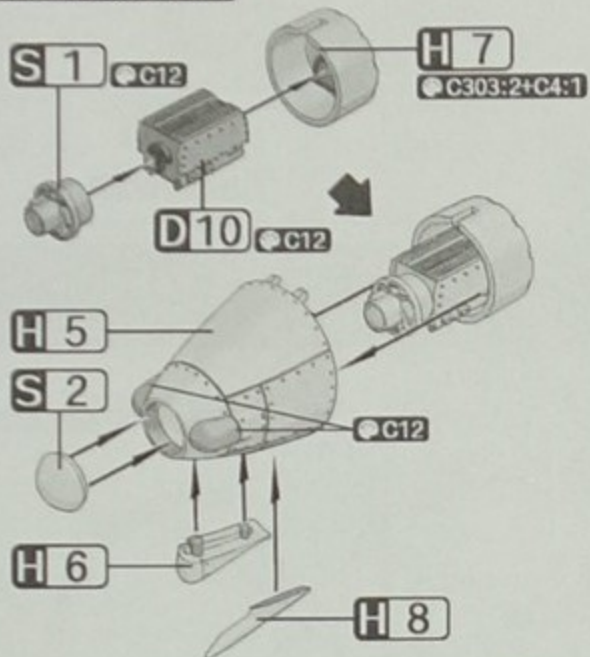

关闭状态
Radome Closed

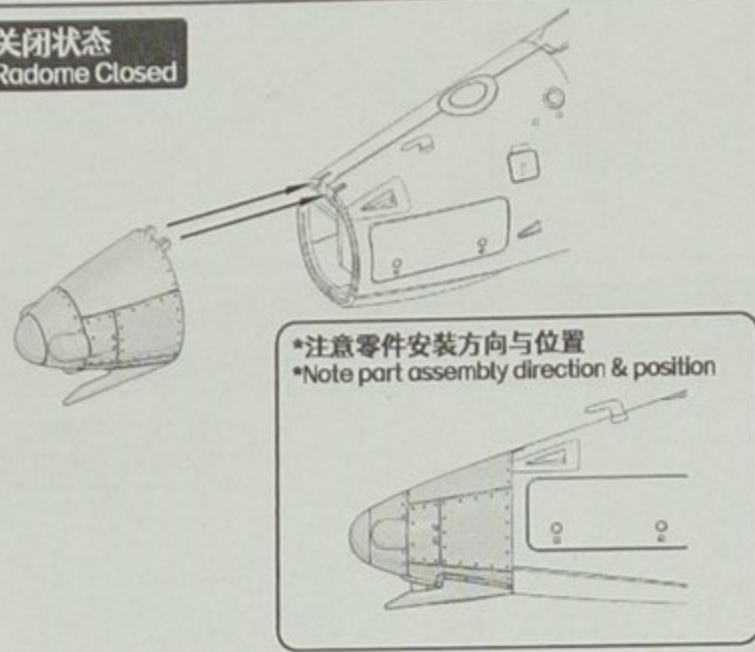

打开状态
Radome Opened

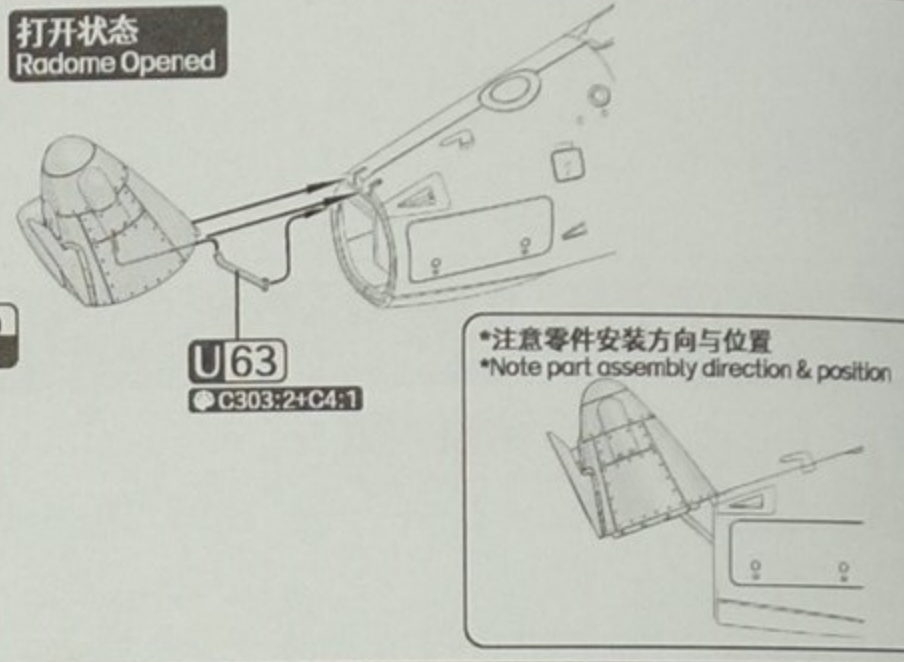

完全打开状态
Nose Section and Radome Opened

*注意零件安装方向与位置
*Note part assembly direction & position

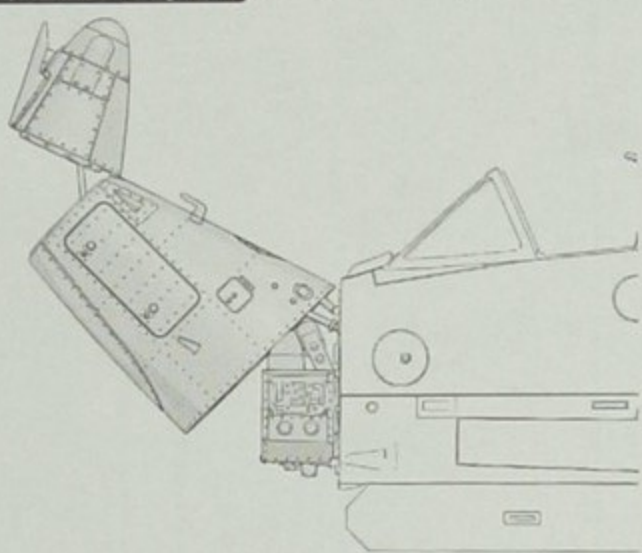

完全关闭状态
Nose Section and Radome Closed

*注意零件安装方向与位置
*Note part assembly direction & position

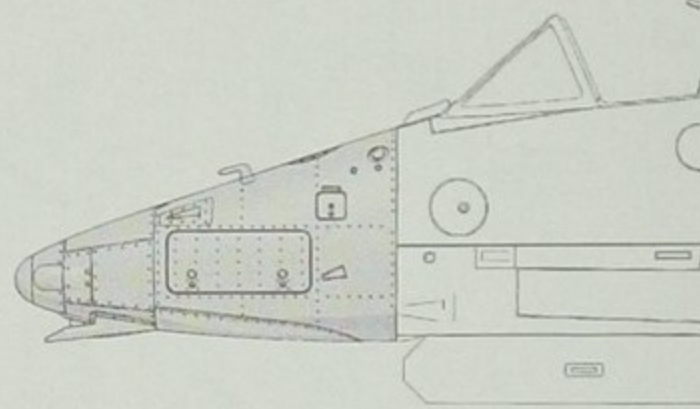

24. 挂架组合 Racks Assembly

3号挂架
STA.3 Rack

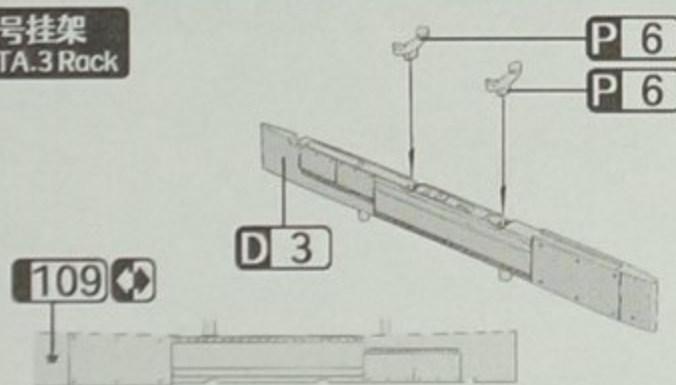

1号挂架
STA.1 Rack

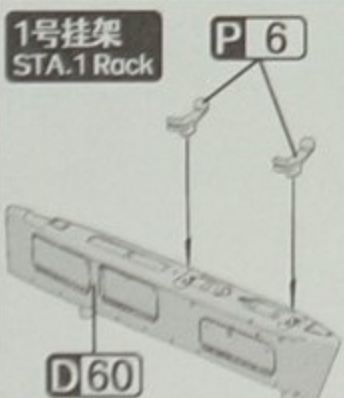

5号挂架
STA.5 Rack

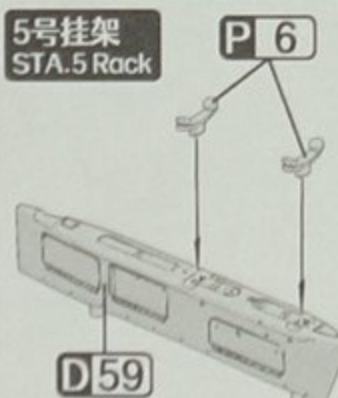

2号挂架
STA.2 Rack

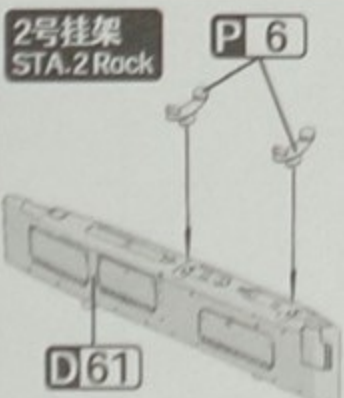

4号挂架
STA.4 Rack

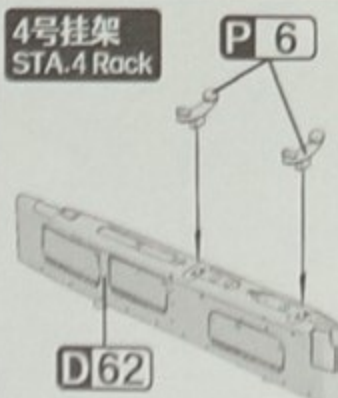

对称制作
Both sides

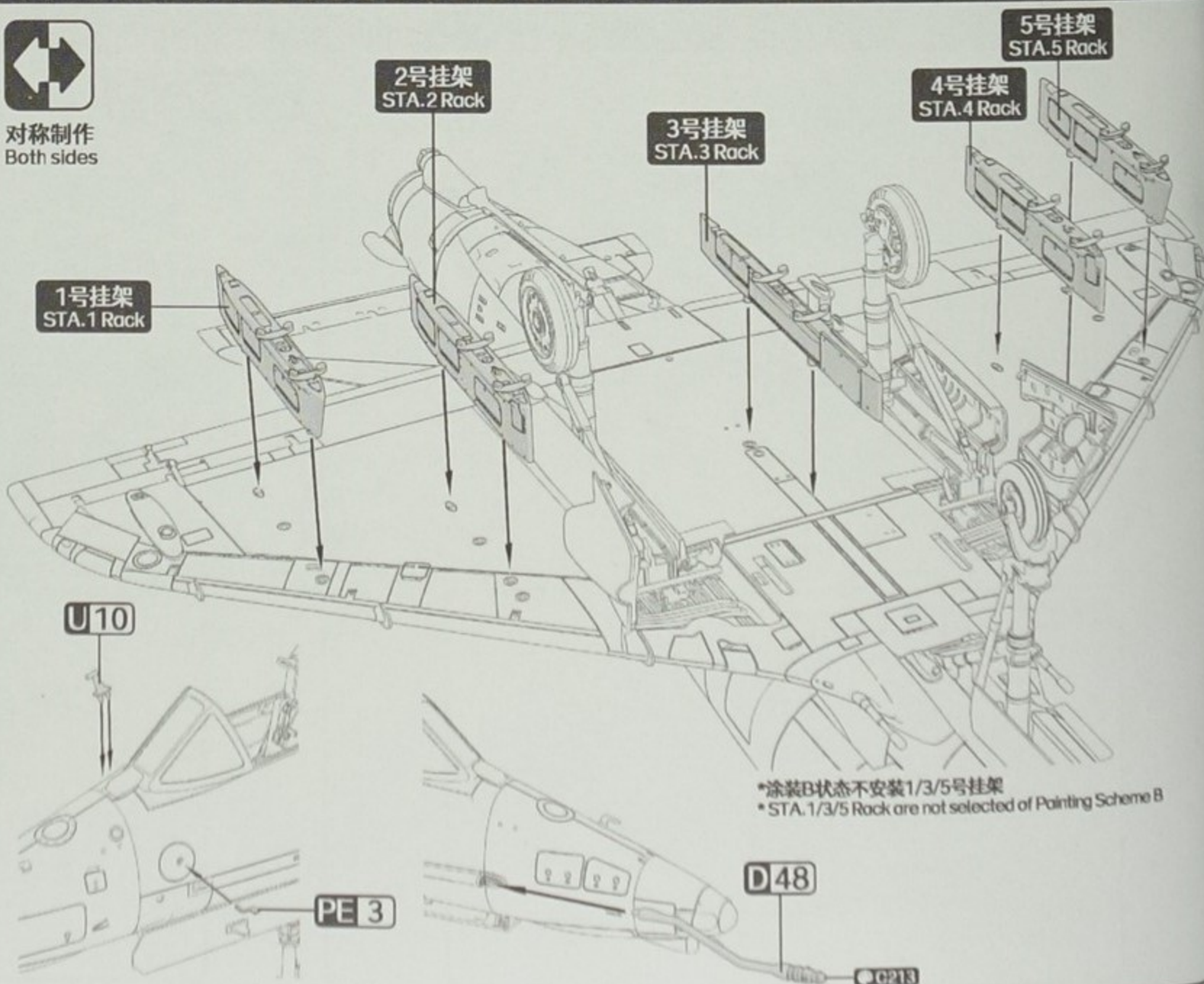

25. 弹药、挂载组装 Loadouts Assembly



选择其一
Choose one



优先制作
Assemble first

副油箱
Drop Tank

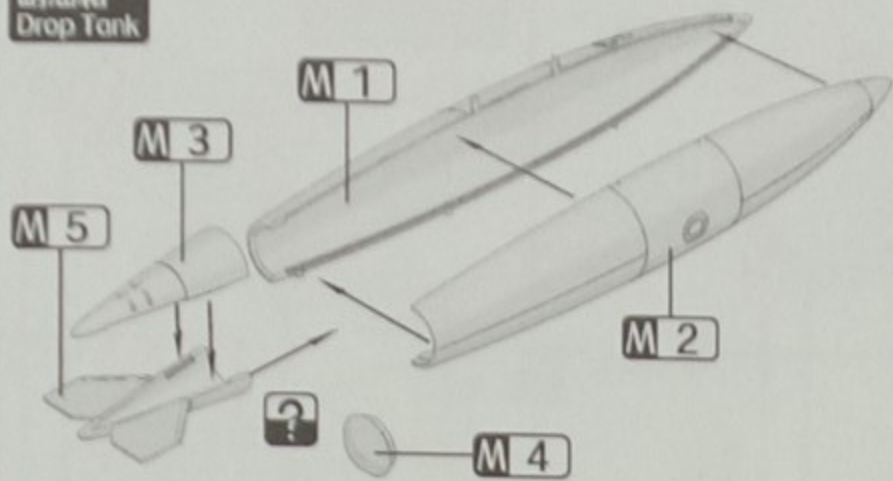

2、4号挂架挂载时
For STA.2/STA.4 Rack



3号挂架挂载时
For STA.3 Rack



LAU-10/A 火箭发射巢
LAU-10/A ZUNI Rocket Pods

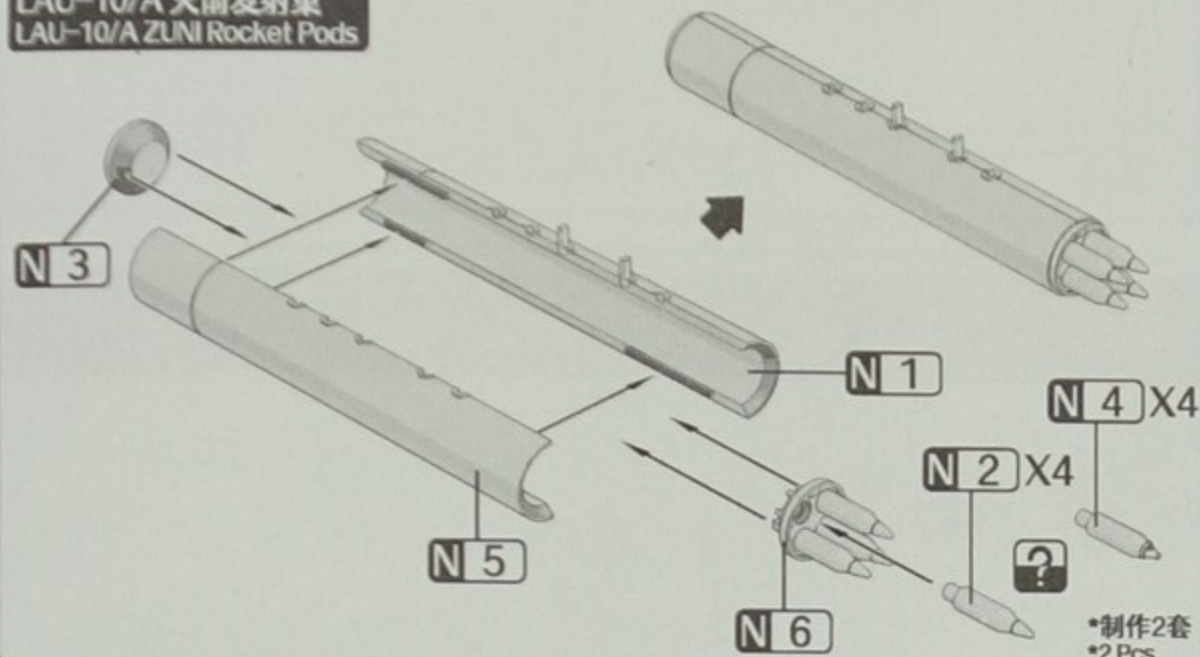

MK 82高爆炸弹
MK 82 500-lb Bomb

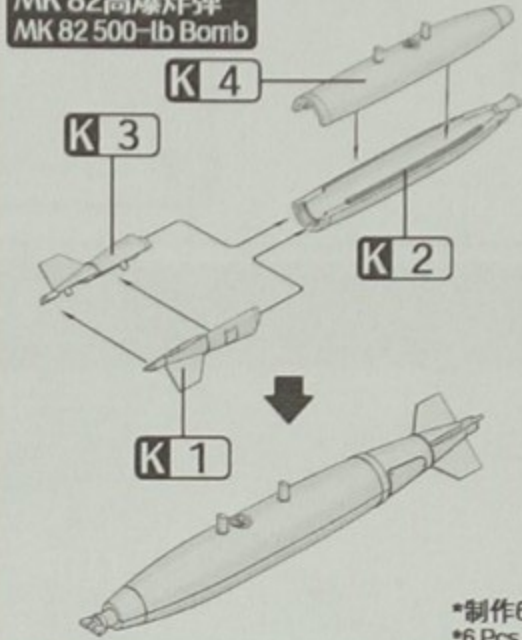

MK 81 "蛇眼" 减速炸弹
MK 81 "Snakeye" 250-lb Bomb

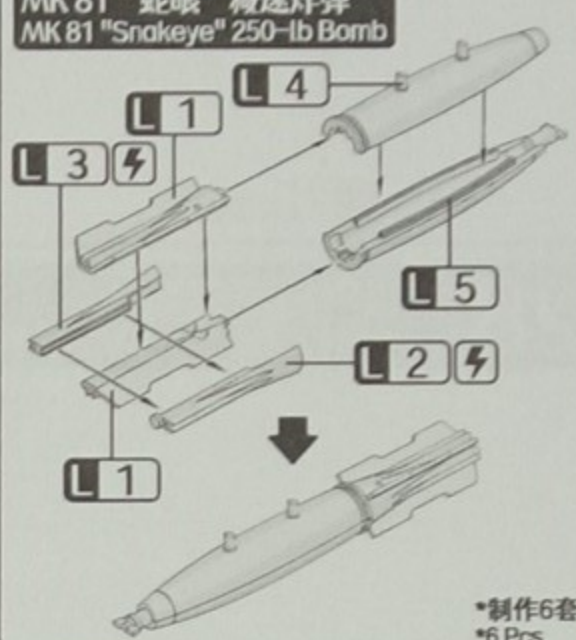

26. MER/TER挂架组装及组合 MER/TER Ejector Rack Assembly



选择其一
Choose one

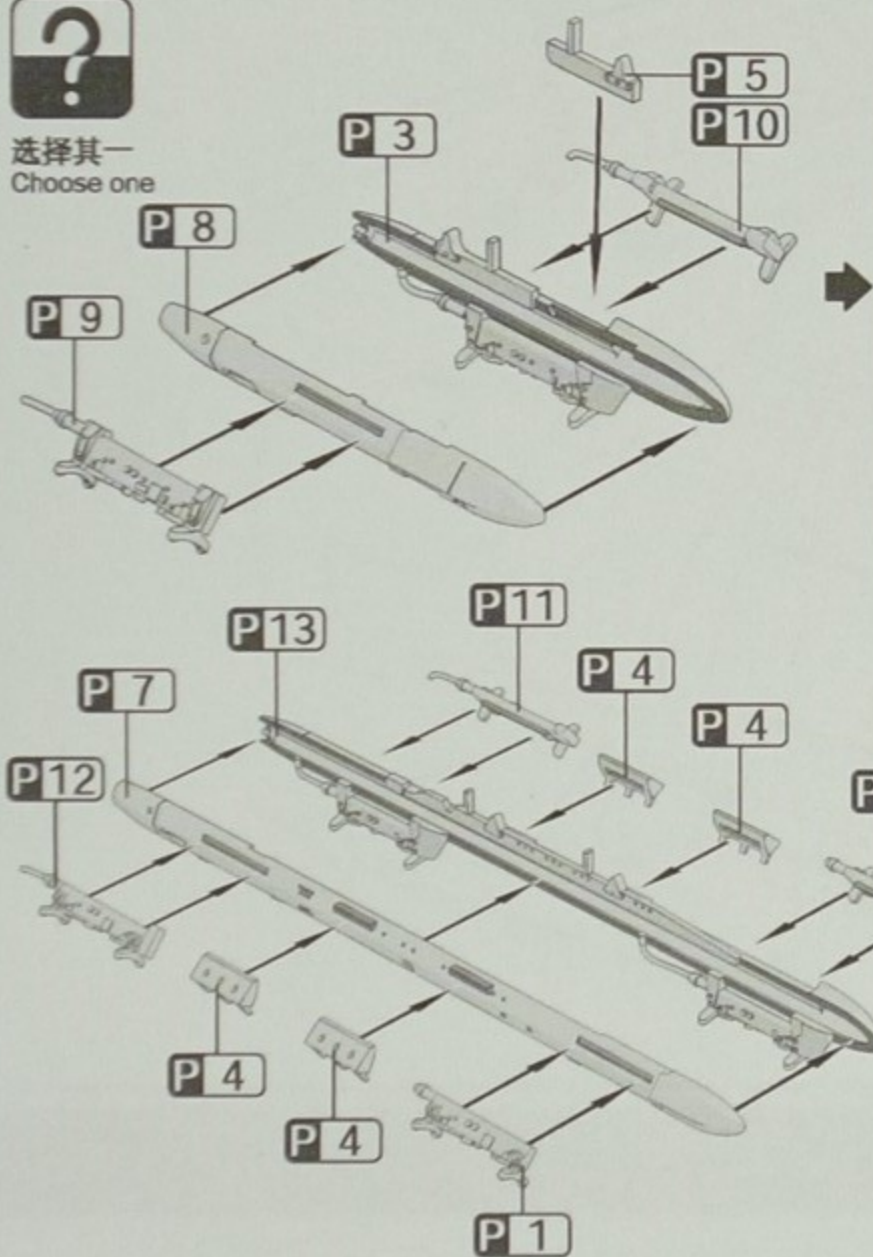

选装TER挂载MK 82
MK 82 500-lb Bomb On TER

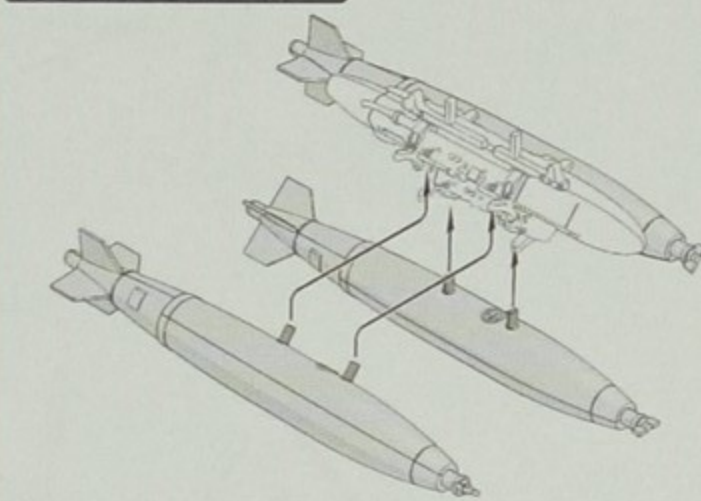

选装TER挂载MK 81 "蛇眼"
MK 81 "Snakeye" 250-lb Bomb On TER

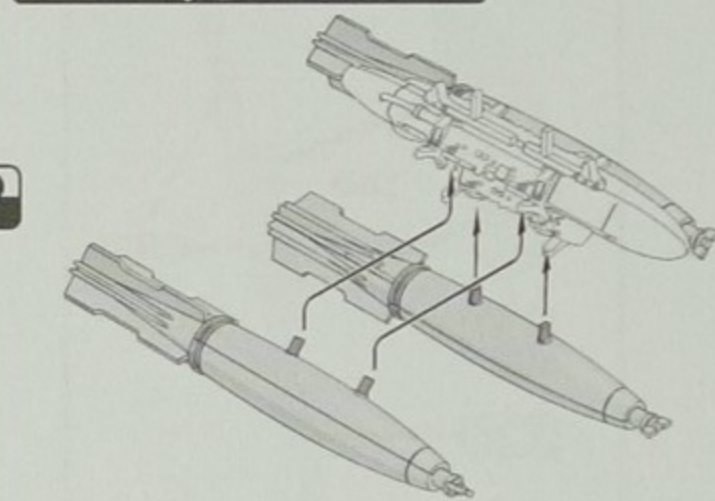

选装MER挂载MK 82
MK 82 500-lb Bomb On MER

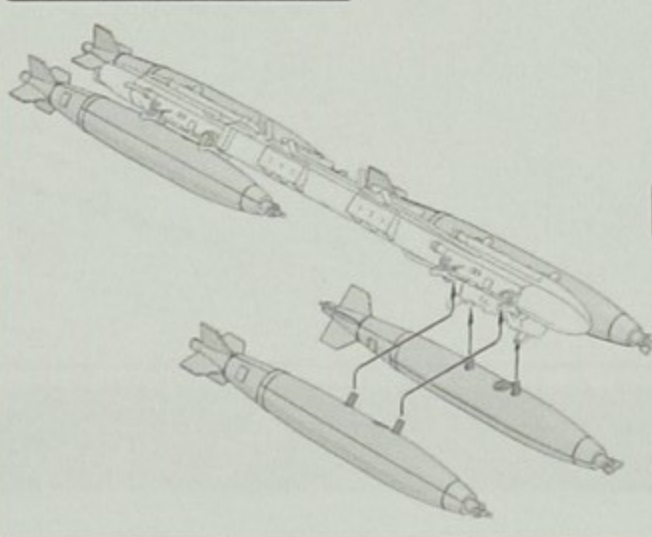

选装MER挂载MK 81 "蛇眼"
MK 81 "Snakeye" 250-lb Bomb On MER

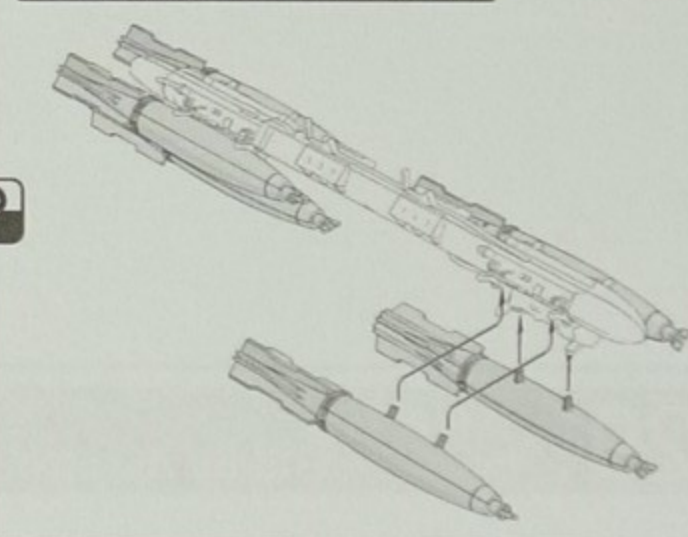

挂载实例1
Loadout Sample1

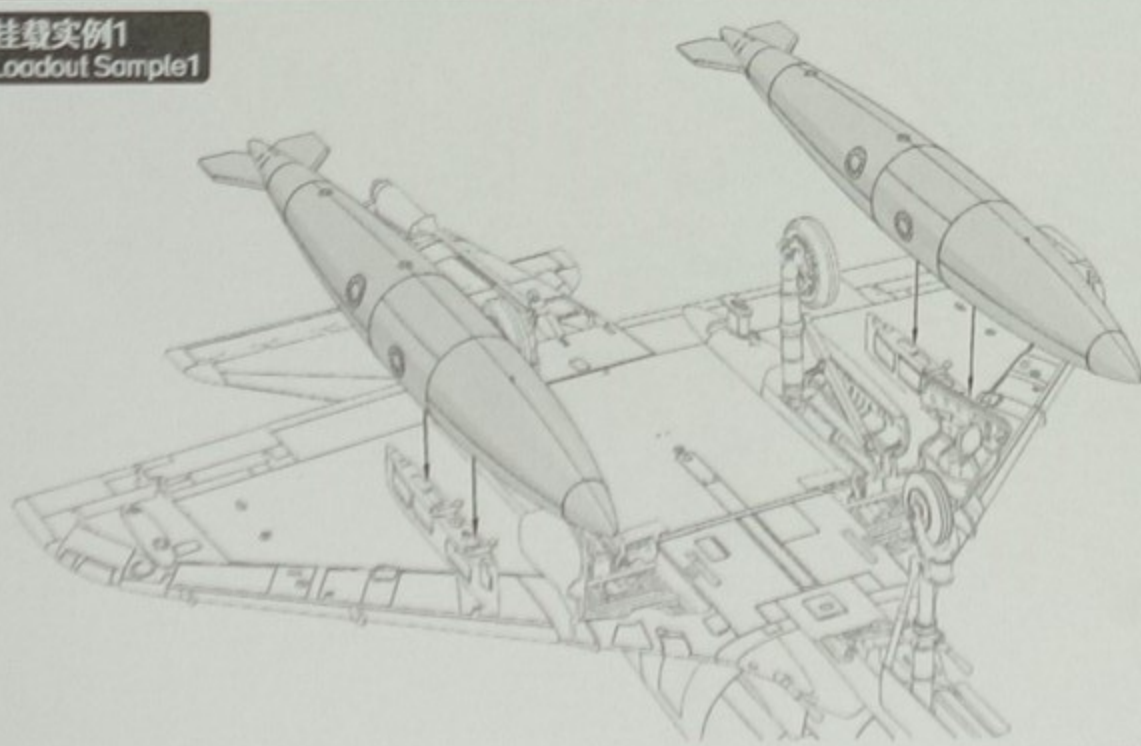

挂载实例2
Loadout Sample2

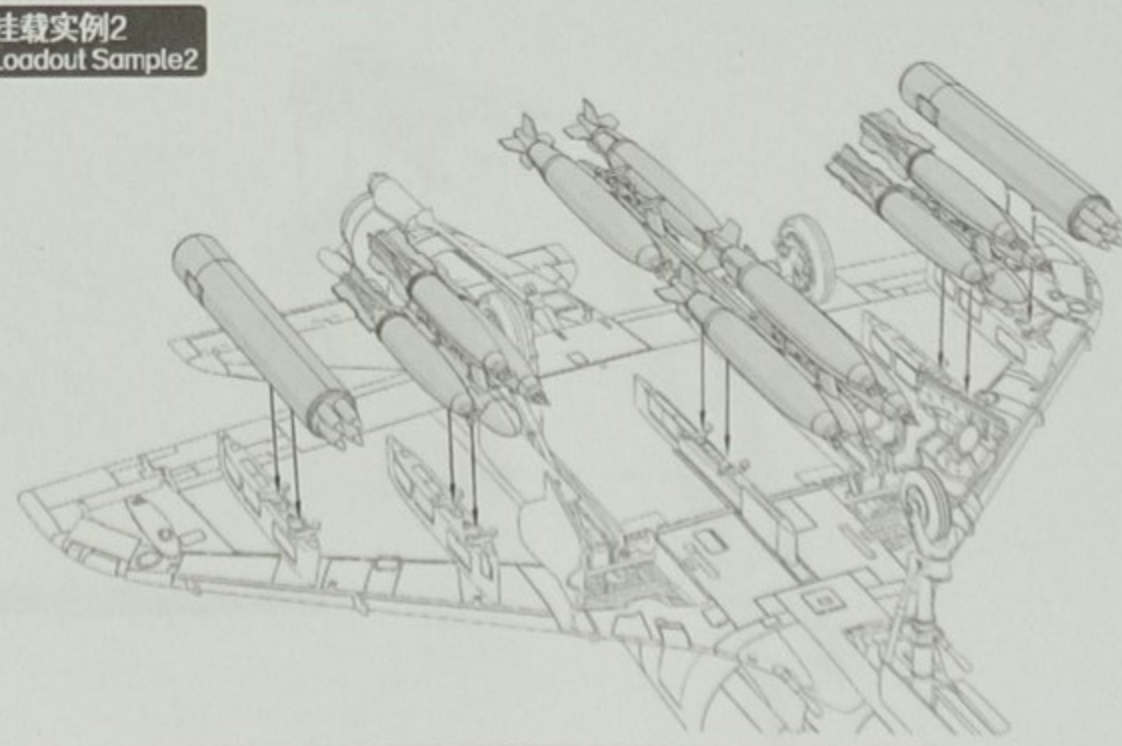

可根据需要制作挂架及变更挂载方案
Could Change Loadouts According To Different Loading Status

*由于机翼内侧挂架靠近机身主起落架门，因此两种组合挂架的内侧挂点一般不安装挂载。而且由于每种炸弹都有其固定尺寸与弹道，因此不同型号的炸弹在同一个挂架的混合挂载是不被允许的。

* Since the No.2/No.4 STA are close to the main landing gear doors, the Inboard loading side of MER/TER will not usually be used. And different type of bombs in same rack is also not allowed.

27. 座舱盖组装及组合 Canopy Assembly

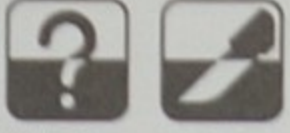

选择其一 切除
Choose one Cut

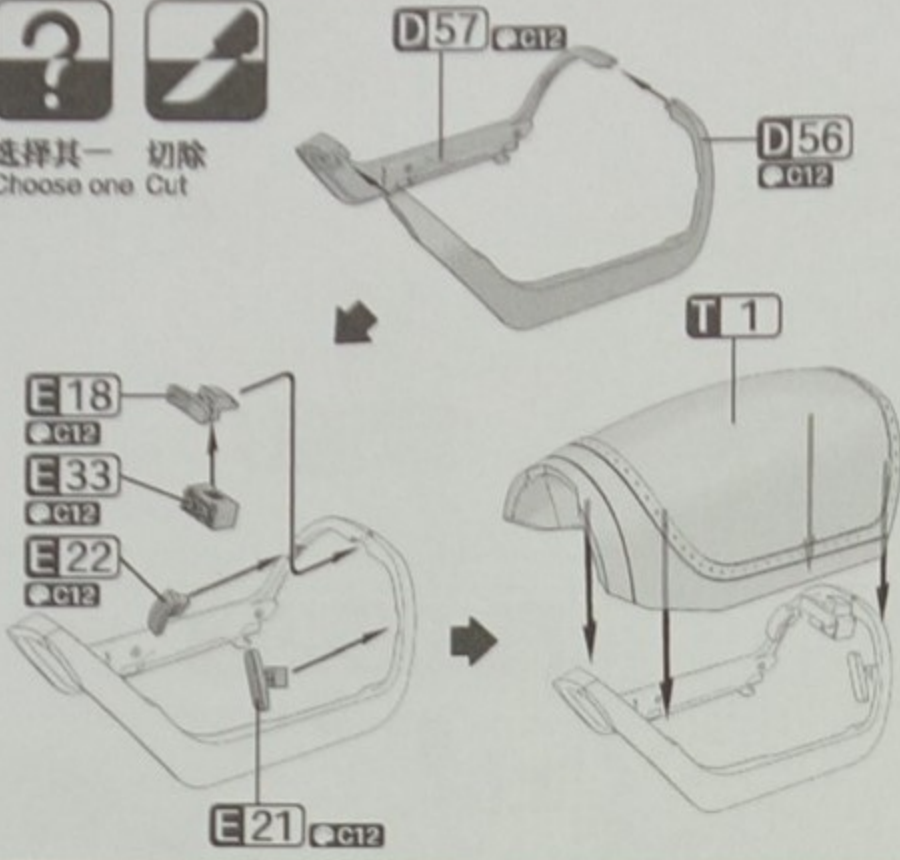

舱盖关闭状态
Canopy Closed

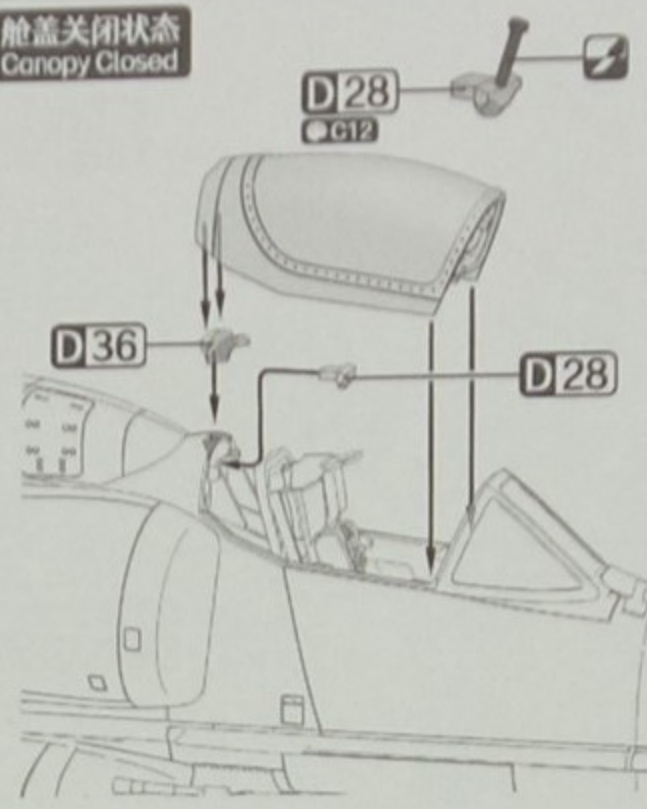

舱盖打开状态
Canopy Opened

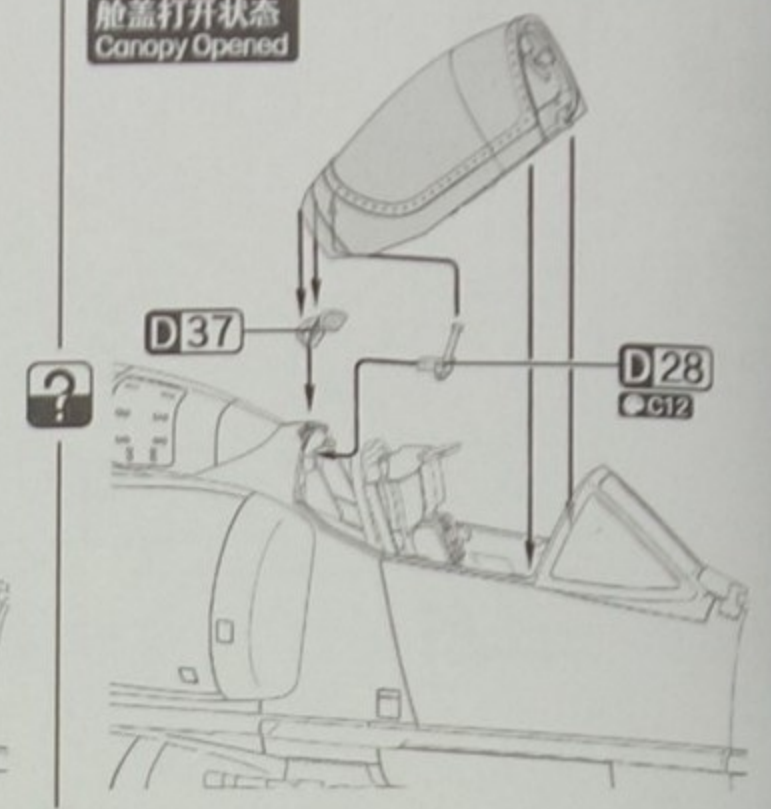

28. 进气道堵盖制作 Inlet Covers Assembly

进气道堵盖
Inlet Covers

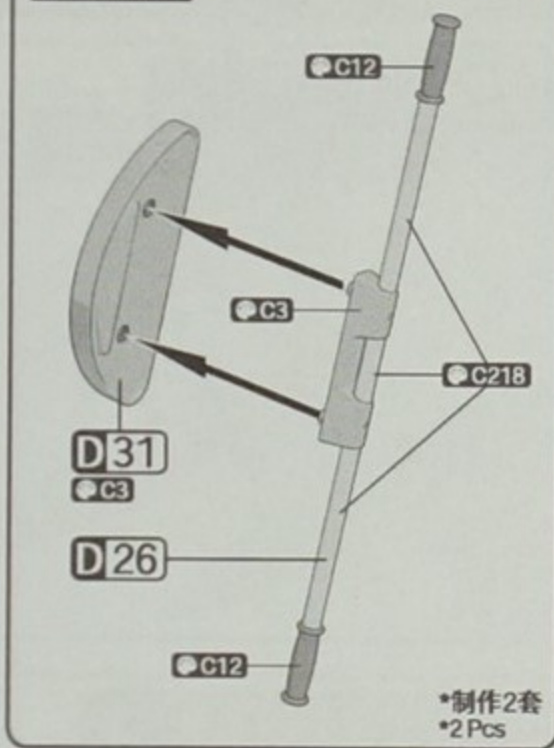

D47
C3

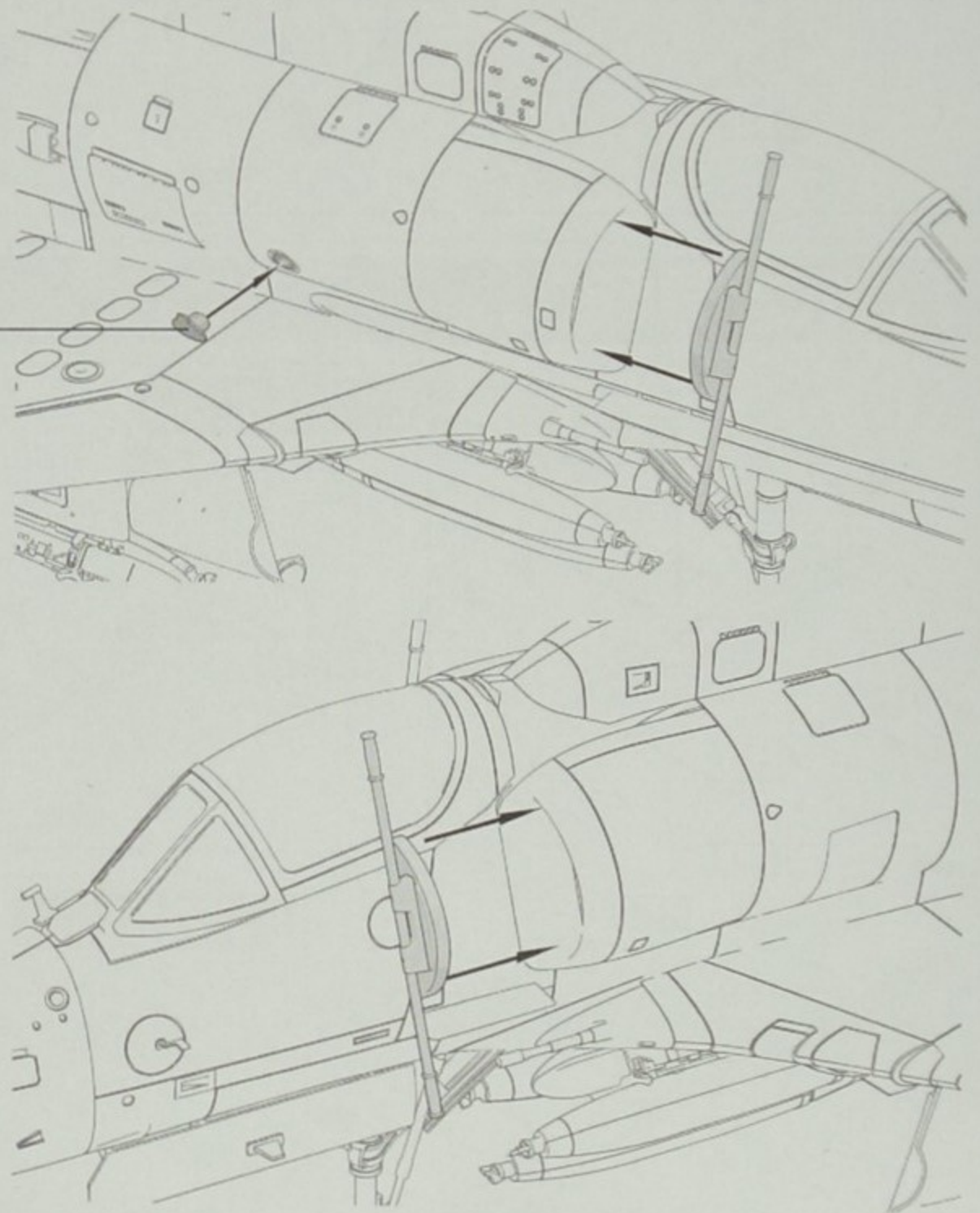

29. 登机梯制作 Boarding Ladder Assembly

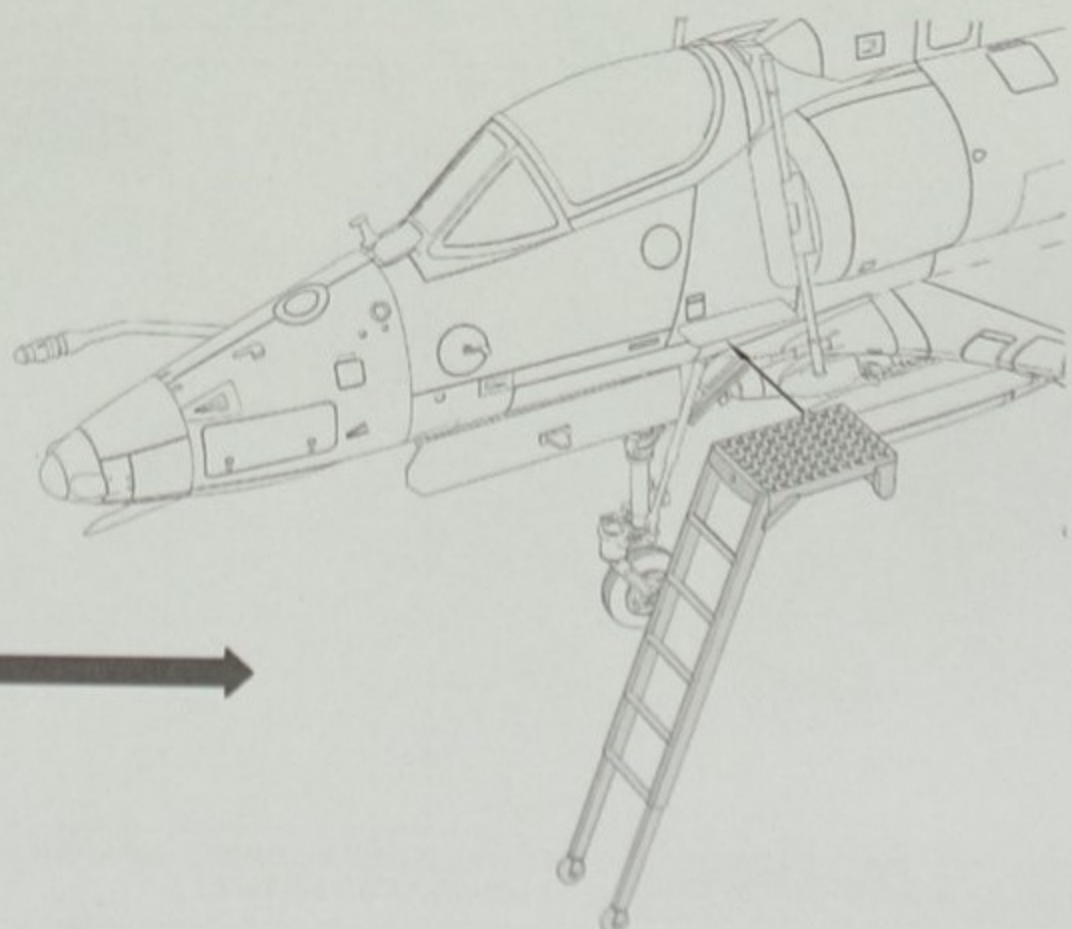
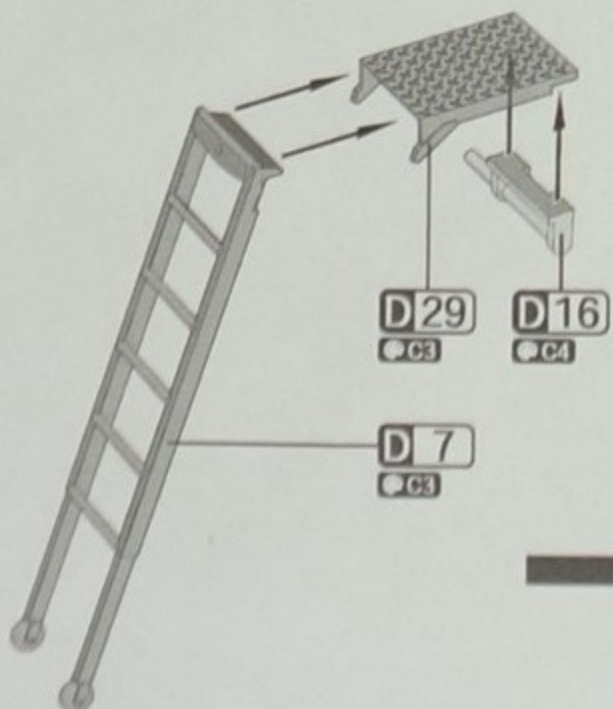

30. 使用镜面贴纸与遮盖贴纸 Use Mirror Stickers And Mask Stickers

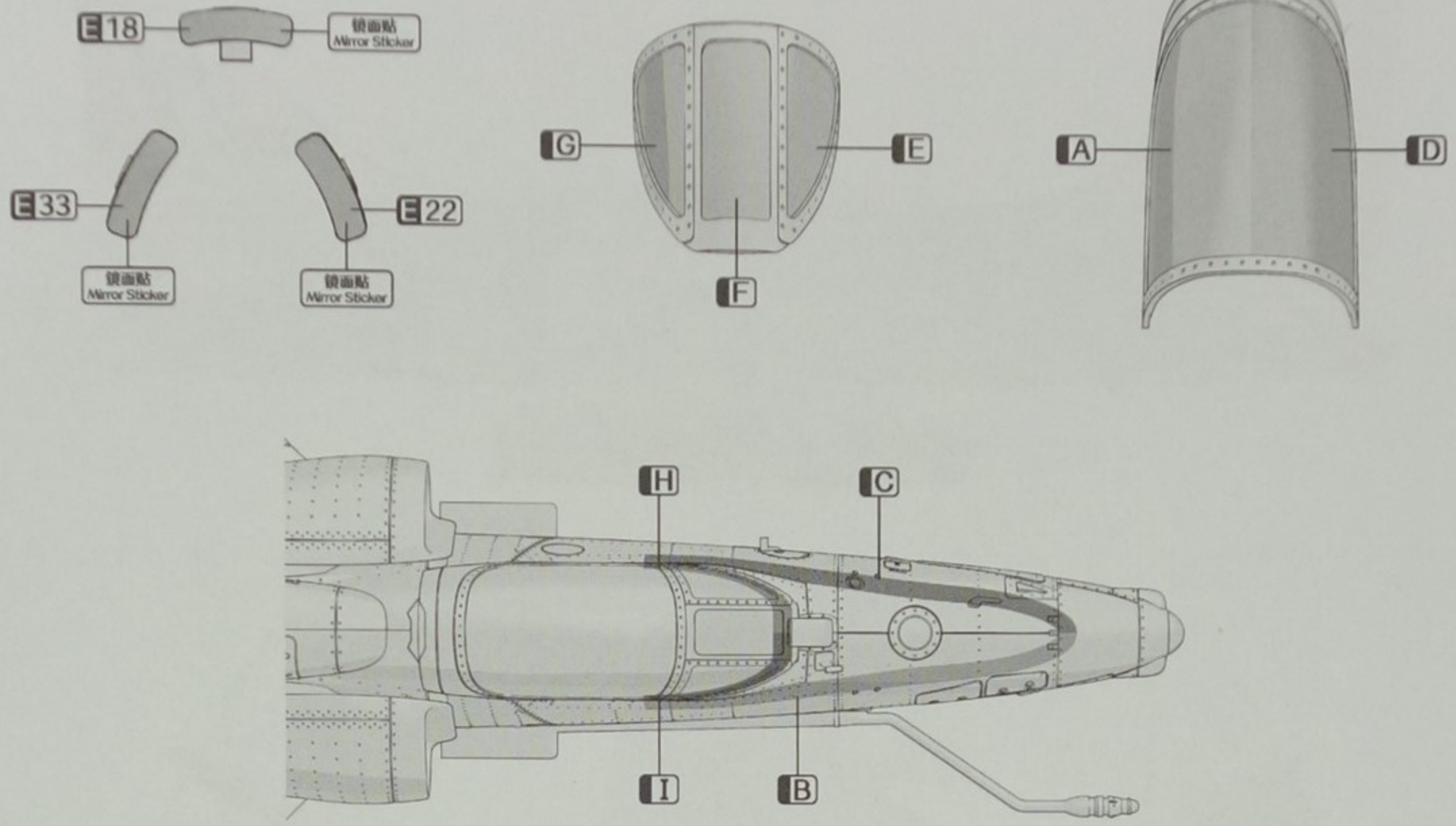

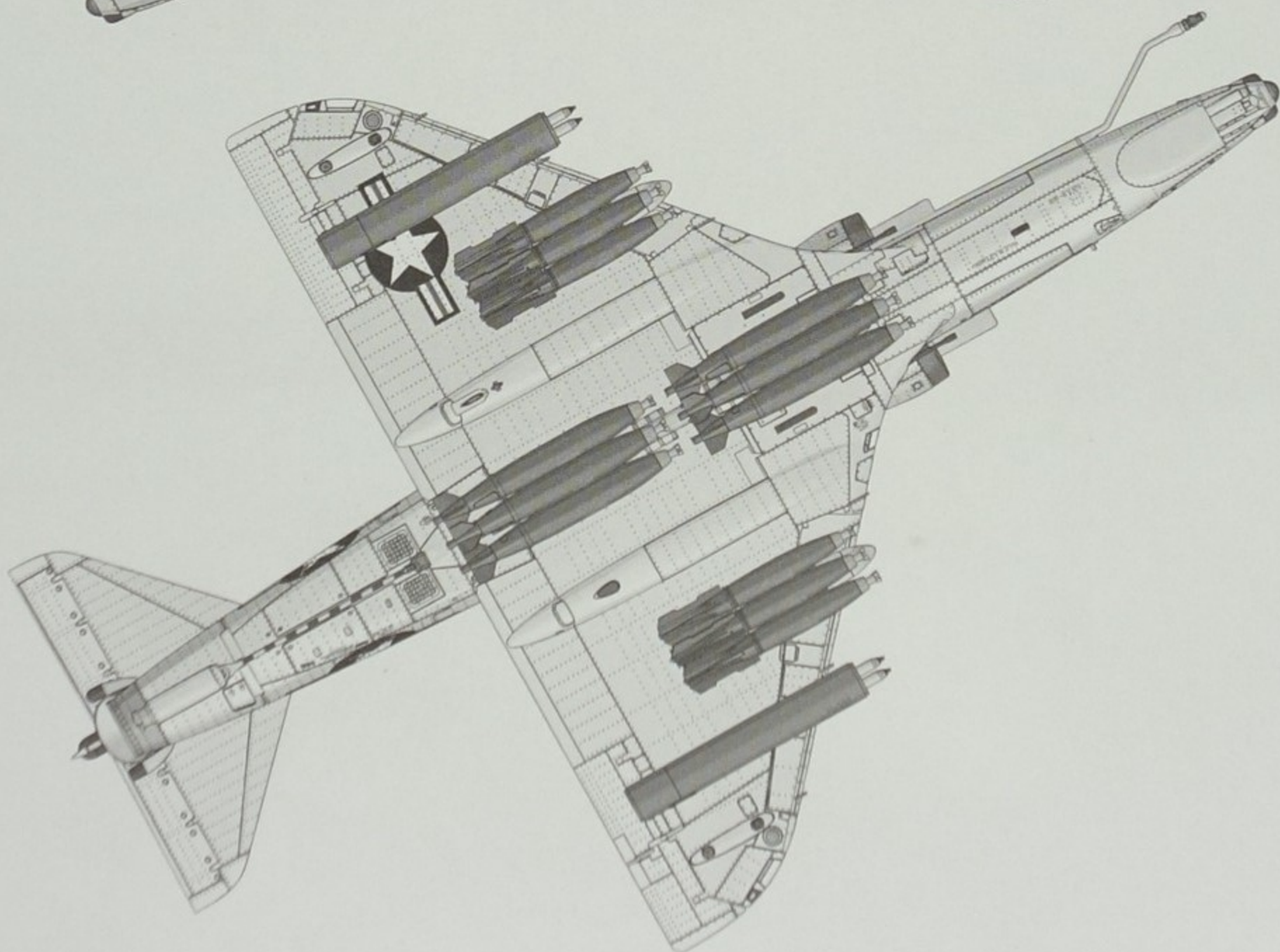
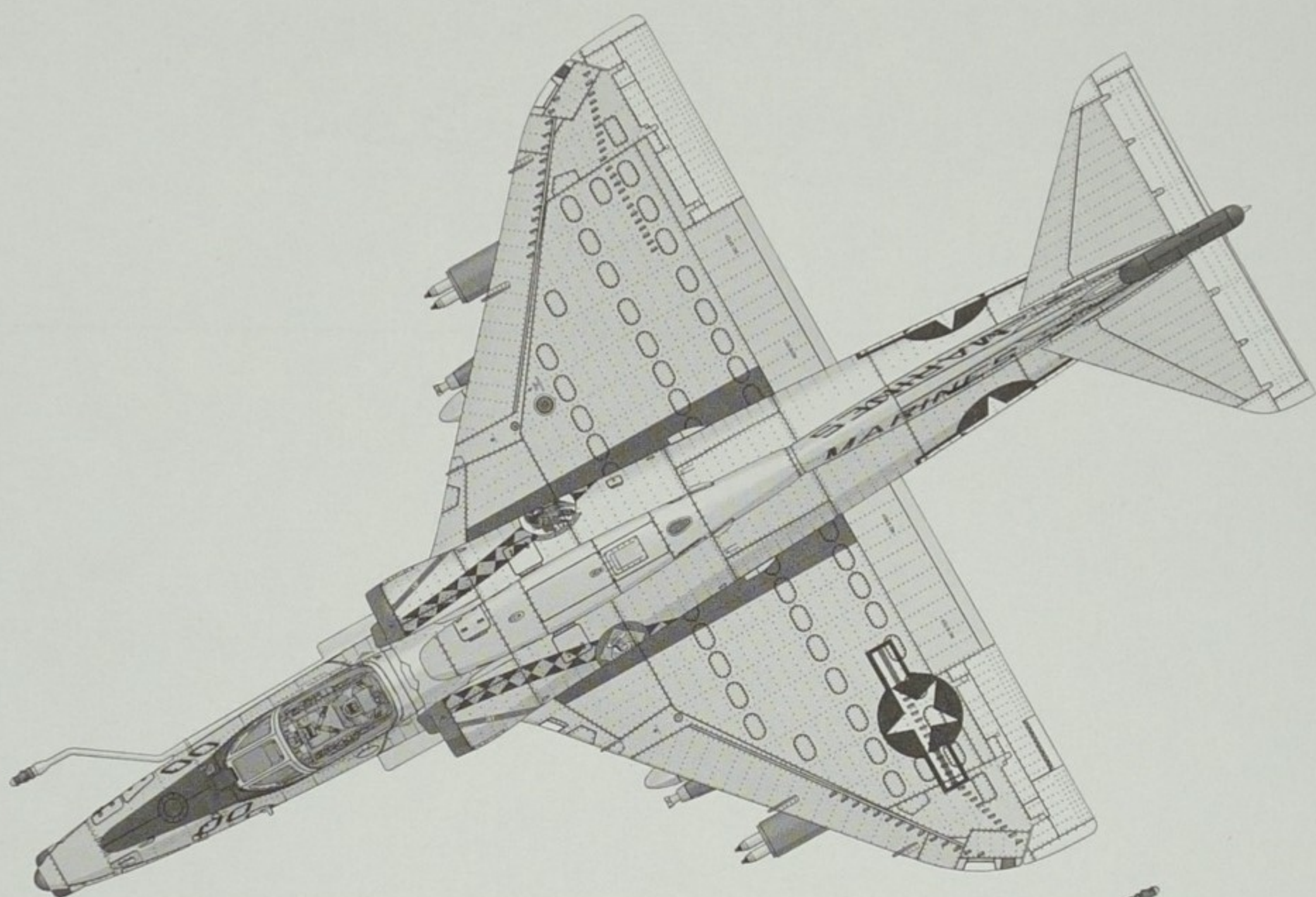
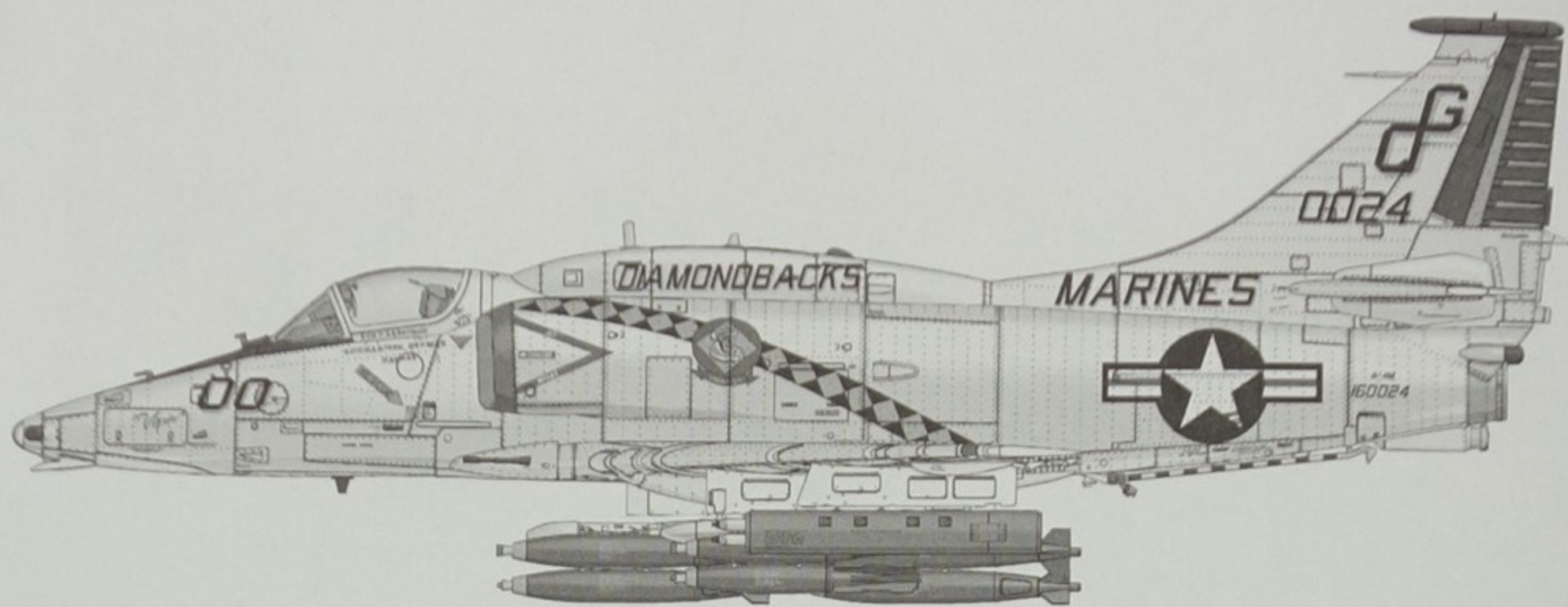

美国海军陆战队VMA-131攻击机中队，宾夕法尼亚州威洛格罗夫海军航空站，1994年6月22日
US Marine Corps - Marine Attack Squadron 131 (VMA-131) Naval Air Station Joint Reserve Base Willow Grove, June 22, 1994

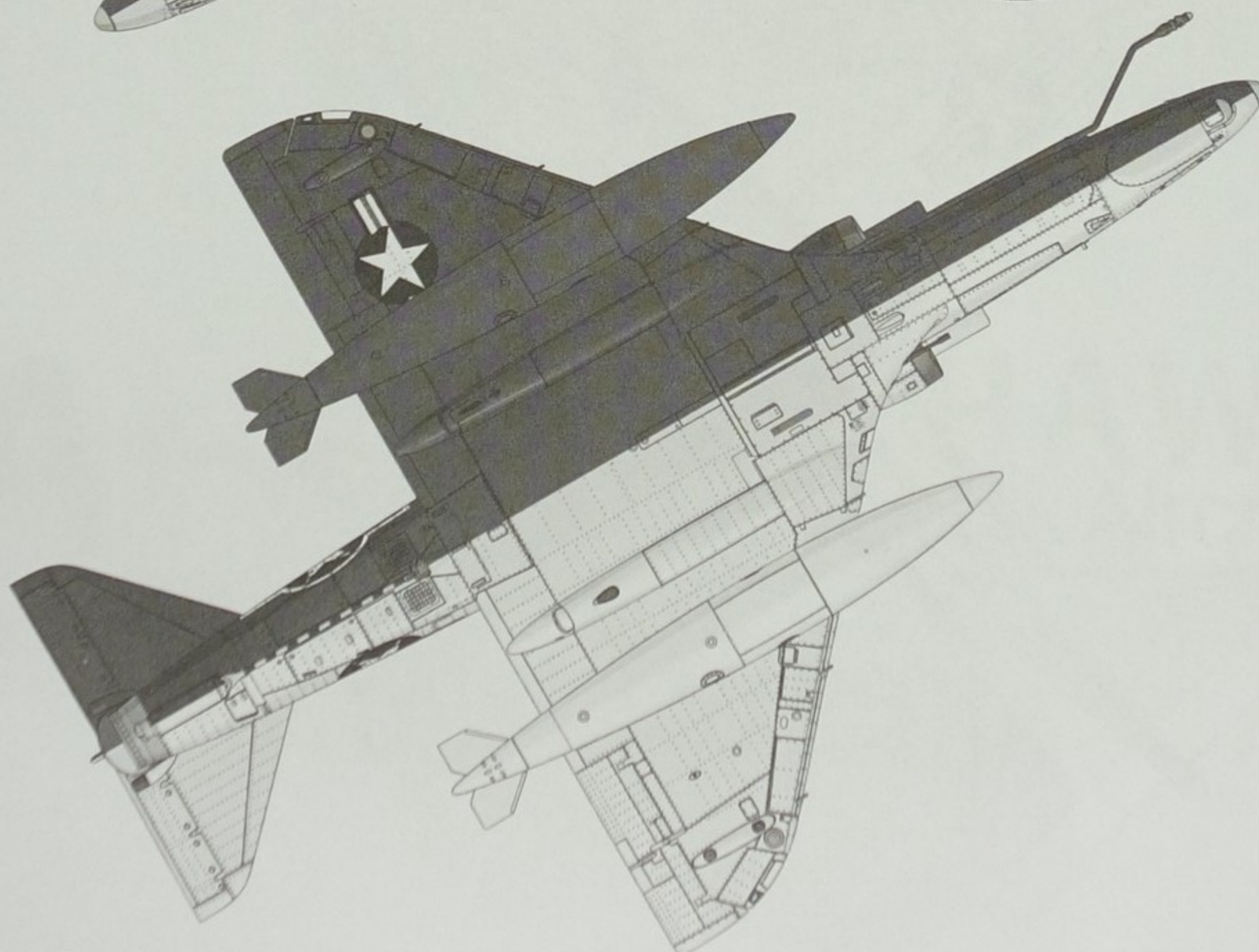
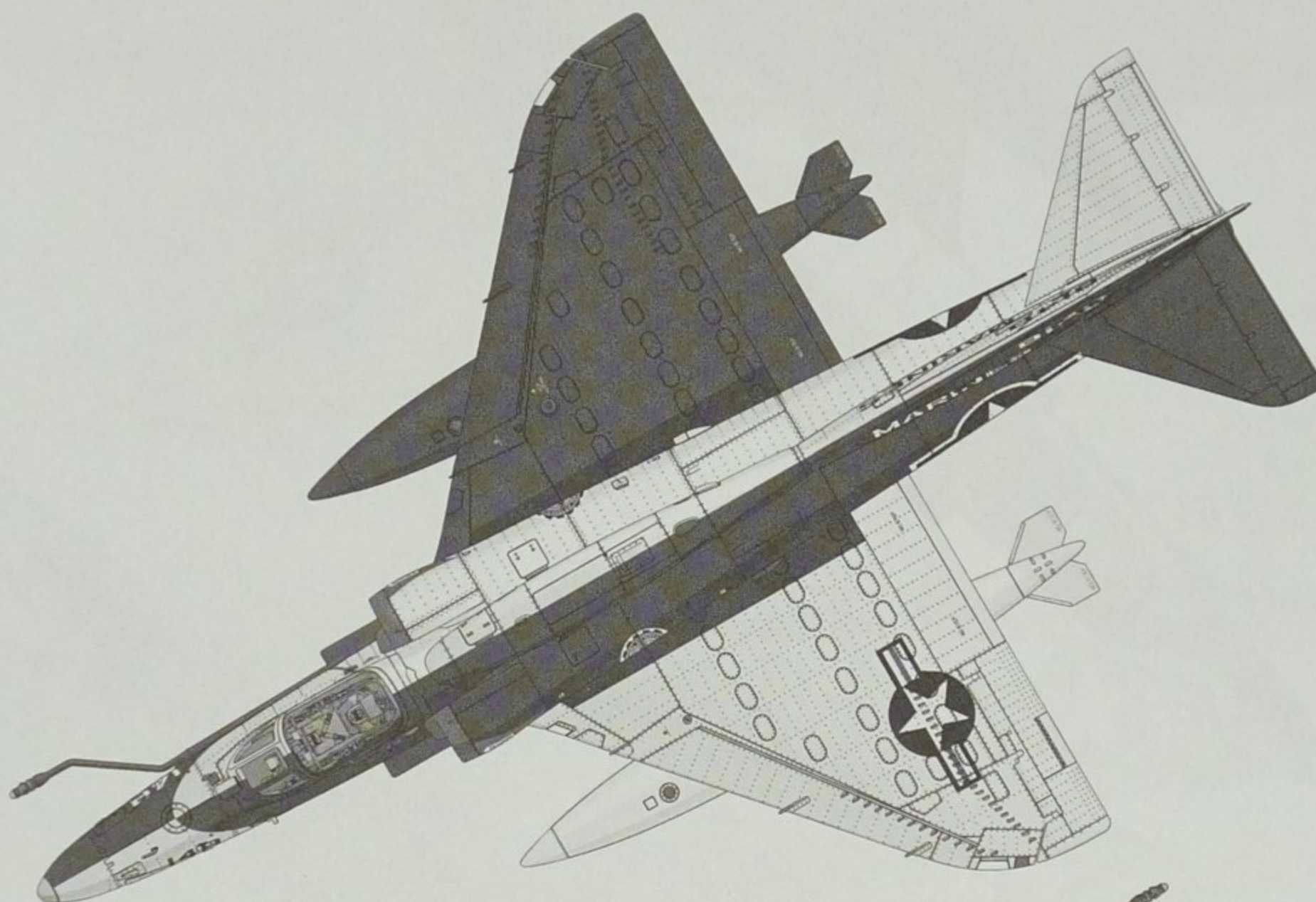
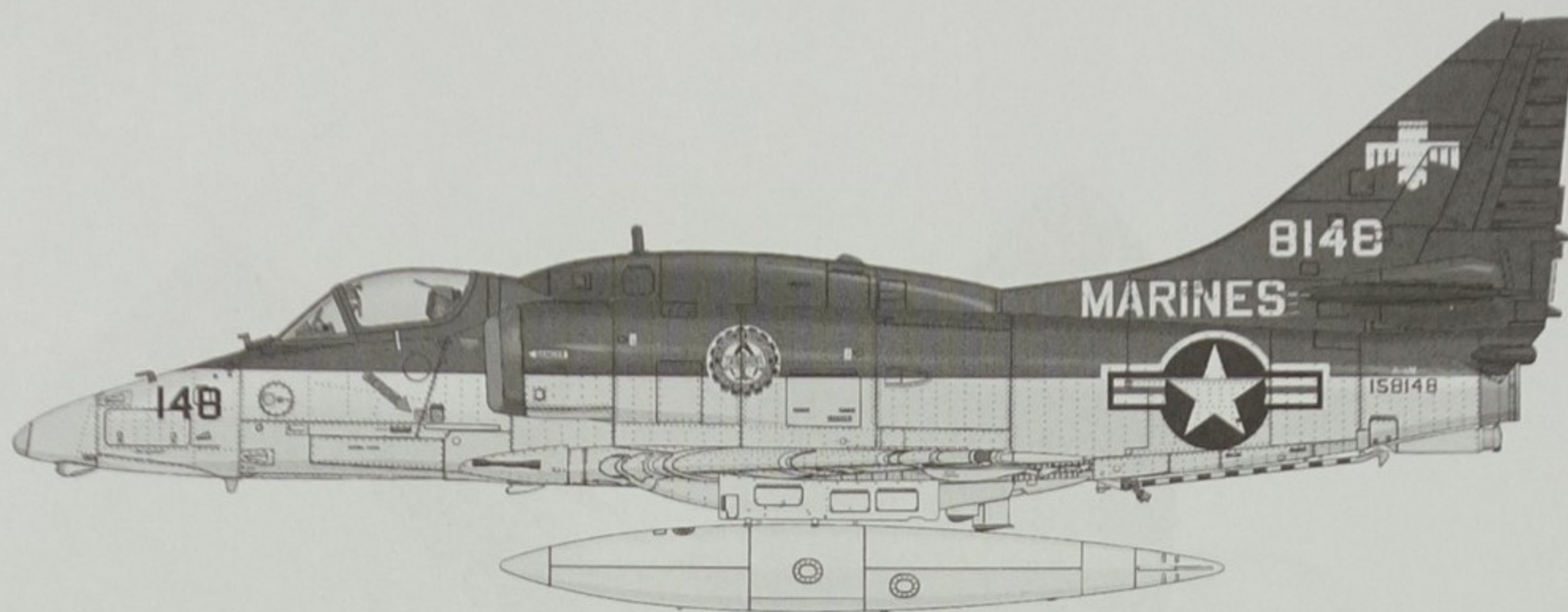

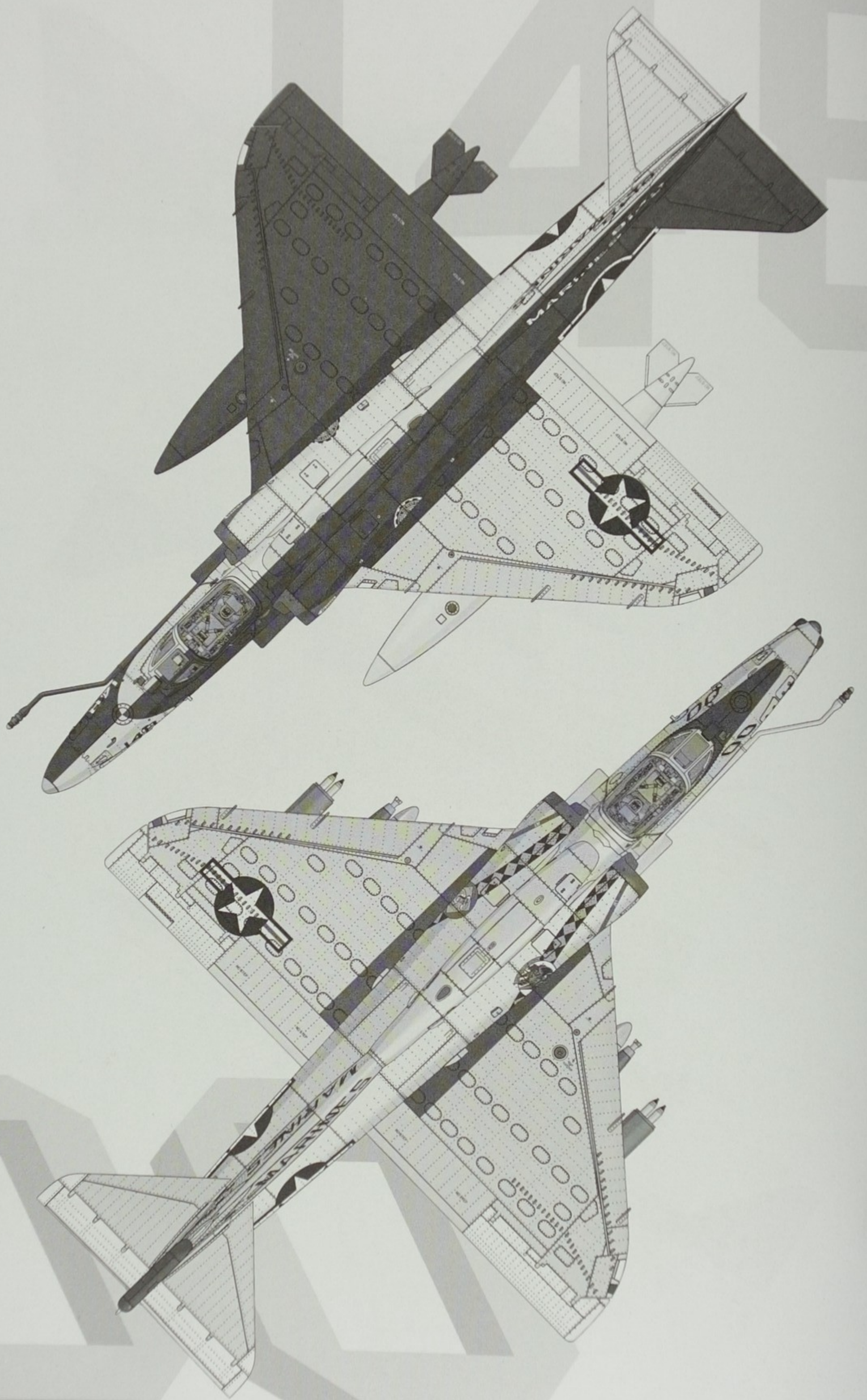

cartograf

2 IN 1

1/48
SCALE

moxing.NET