

# **MAINTRACK MODELS**

79 Queens Road, Hastings, East Sussex. TN34 1RL  
Telephone: 0424 437428

## **Clear-fix Decals**

# **Phantom FG1 FGR2**

SUITABLE FOR THE HASEGAWA 1:48 SCALE

BRITISH PHANTOM KITS

MARKINGS INCLUDED FOR: Nos 2, 6, 14, 17, 19,  
23, 29, 31, 41, 43, 54, 56, 92, 111 Squadrons  
228 O.C.U. 767, 892 Squadrons, R.N. 700P Sqn  
Phantom Training Flight.

## **D483**

Instructions for use:

Using sharp pointed blade, cut out decal to be affixed, and position tacky-side down against surface of model. When you are certain the decal is correctly positioned, release backing sheet by placing a drop of water on the backing paper. After a few seconds, the backing paper may be wiped away.

**IMPORTANT:** Once the decal is wetted, it is fixed on the surface of the model and cannot be moved. Ensure position is correct before releasing the backing paper. Protect the tacky surface of the sheet when not in use, to prevent accumulation of dirt.

**48 scale**



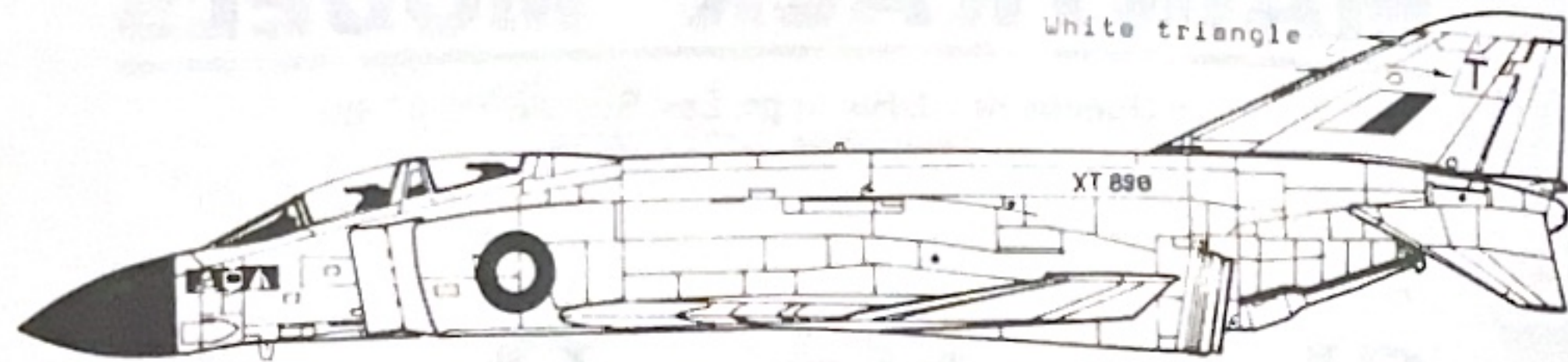

White triangle  
 FGR.2 2 Sqn circa 1976 Note use of white on black details  
 XT 898 'T' Standard Camouflage

438

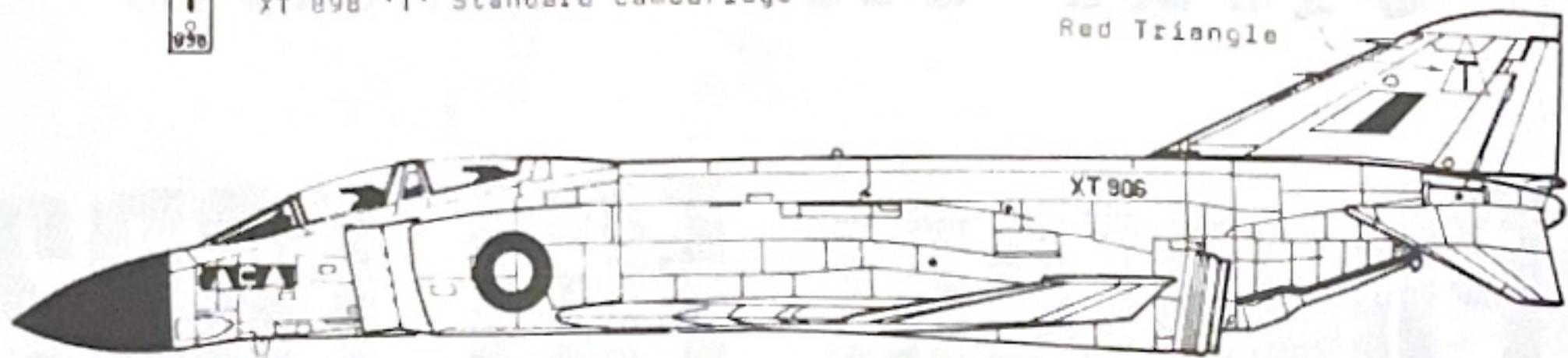

Red Triangle  
 FGR.2 2 Sqn circa 1975 Note use of red on black details  
 XT 906 'T' Standard Camouflage scheme

439

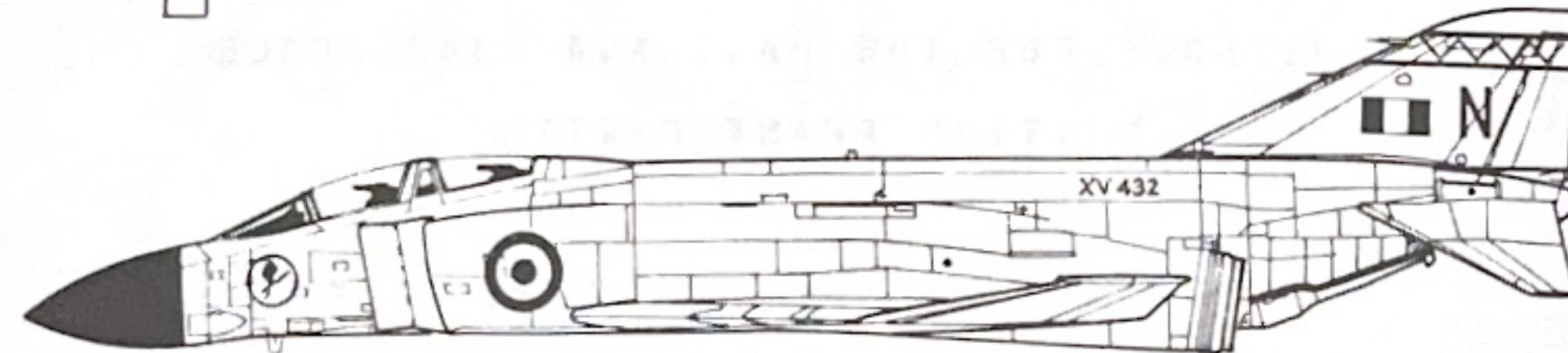

FGR.2 6 Sqn circa 1970 High-viz roundels  
 XV 432 'N' Standard Camouflage scheme

432

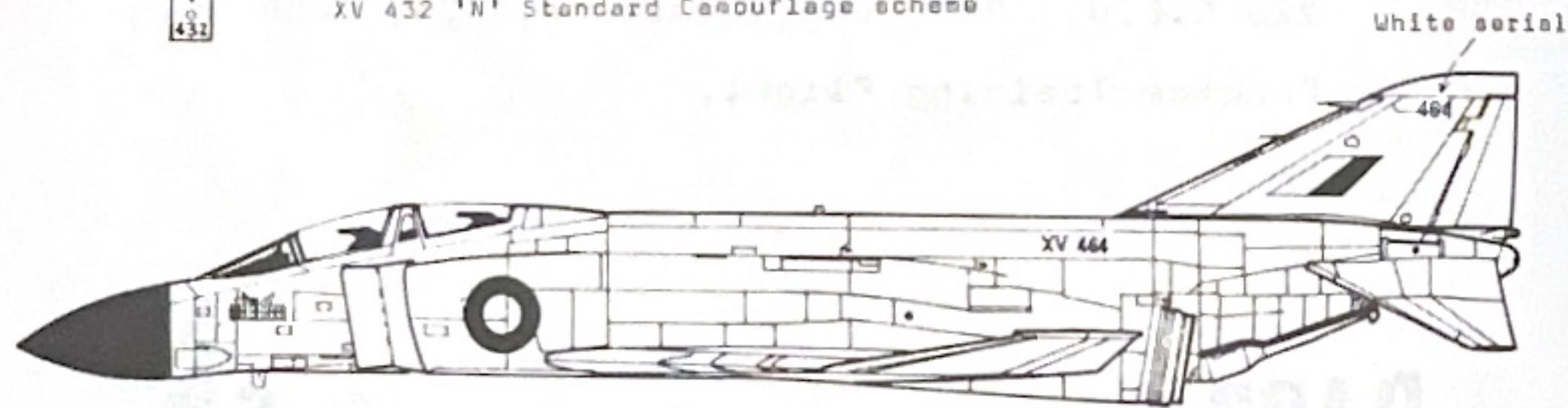

White serial  
 FGR.2 14 Sqn  
 XV 464 Standard Camouflage scheme

424

White No. on door

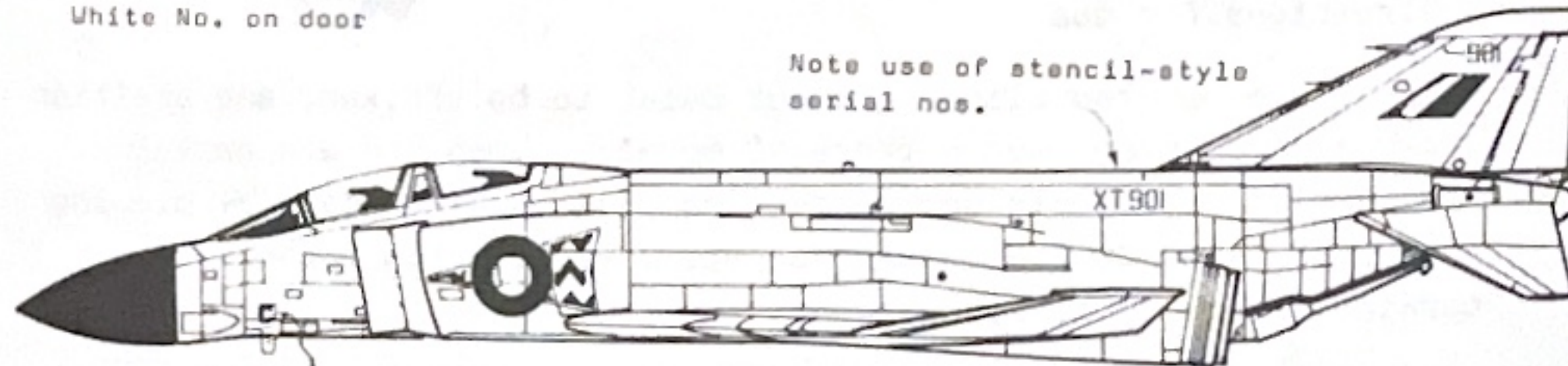

Note use of stencil-style serial nos.  
 FGR.2 17 Sqn circa 1972  
 XT 901 Standard Camouflage scheme

430

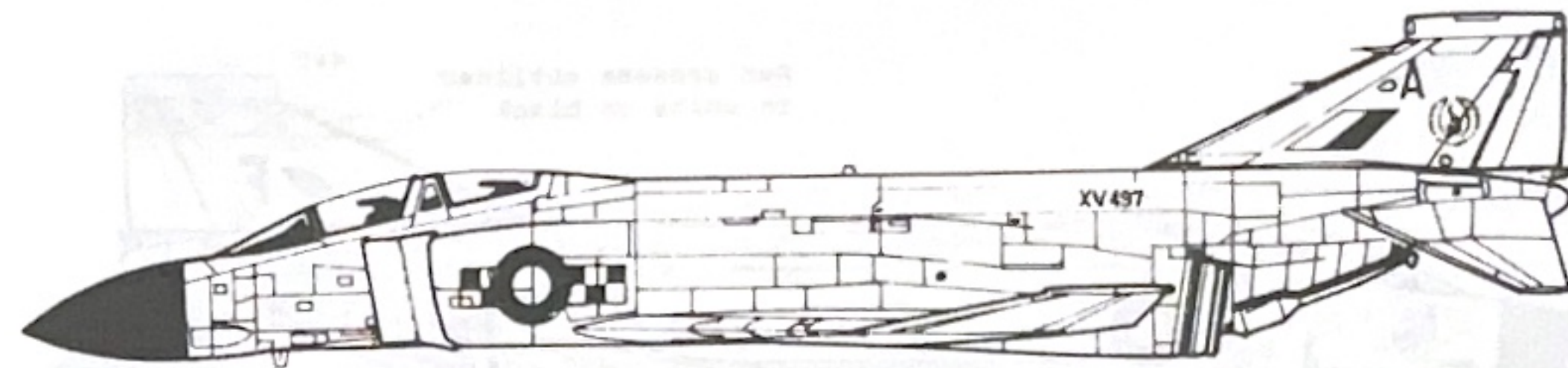

FGR.2 19 Sqn circa 1977  
 XV 497 'A' Standard Camouflage scheme  
 German Rescue markings

437

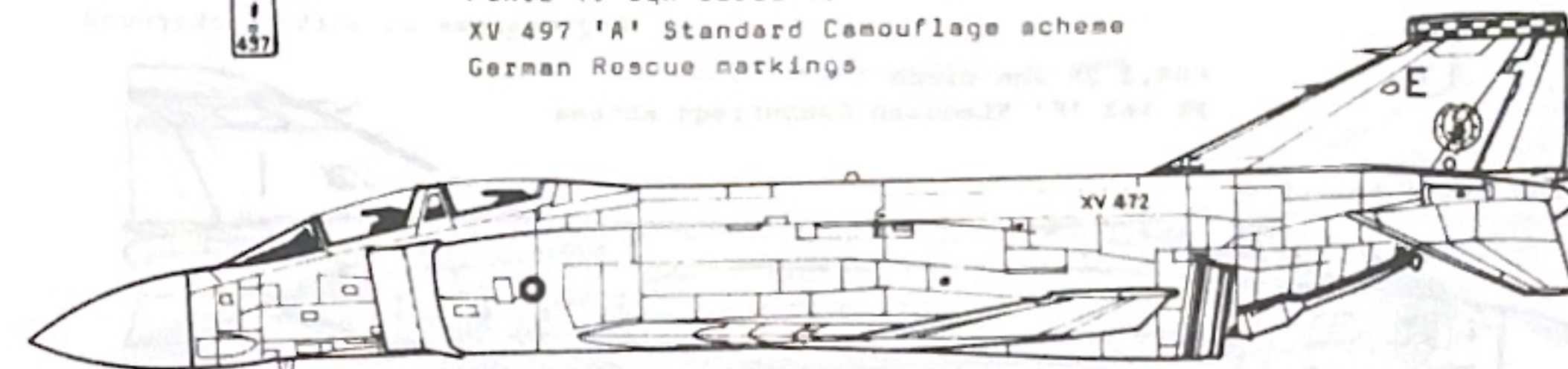

FGR.2 19 Sqn 1987  
 XV 472 'E' Low-viz scheme  
 German Rescue markings

436

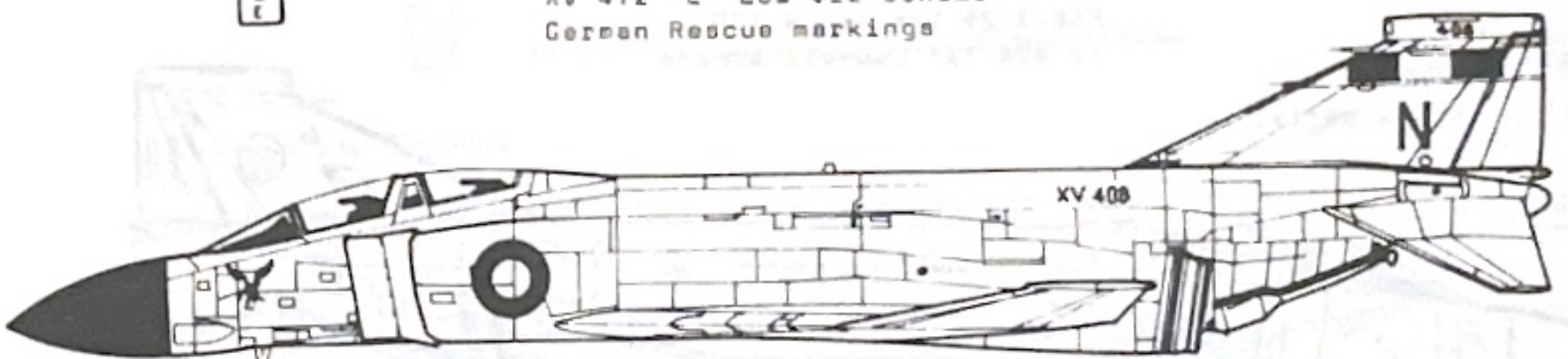

FGR.2 23 Sqn circa 1977  
 XV 408 'N' Standard Camouflage scheme

408

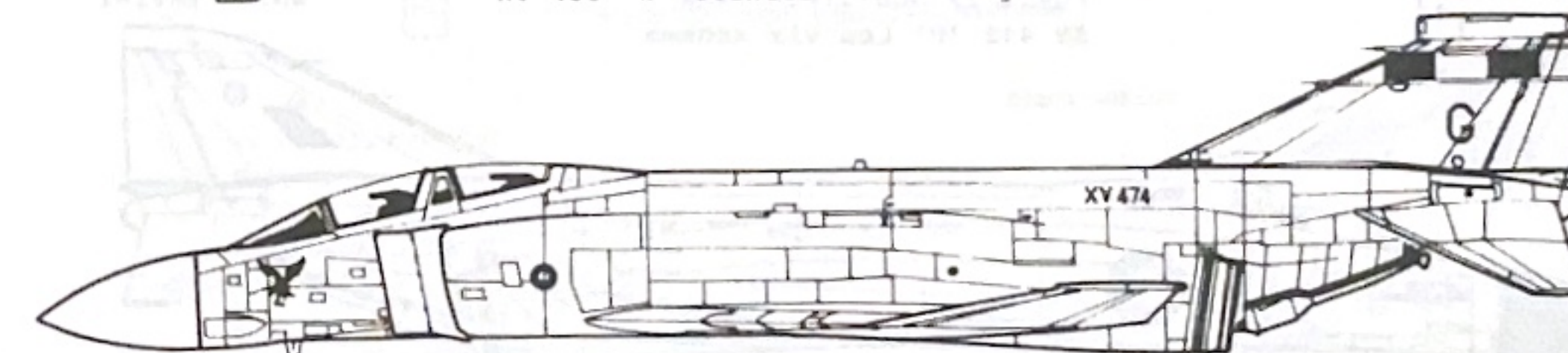

FGR.2 23 Sqn circa 1982  
 XV 474 'G' Low-viz scheme

474

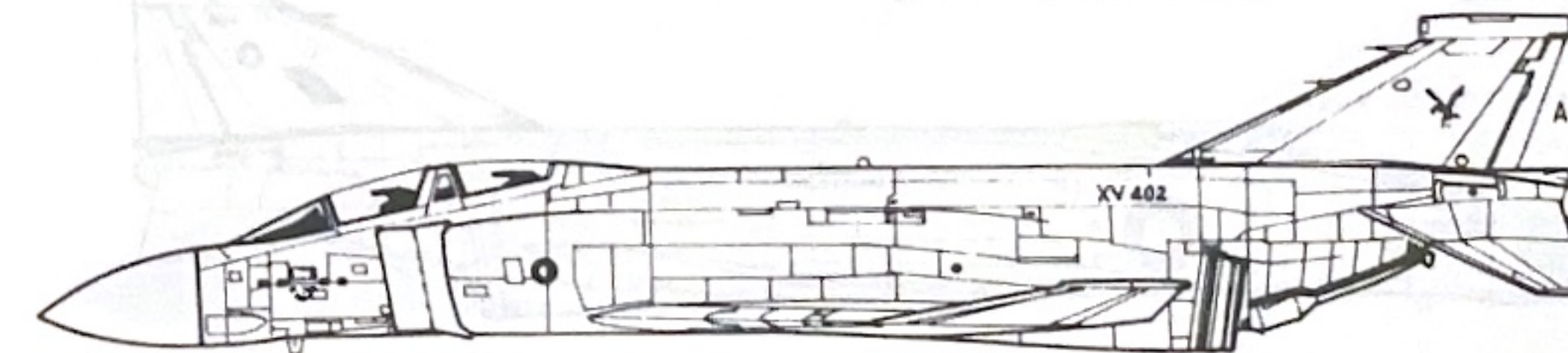

FGR.2 23 Sqn (Falkland Is) 1985  
 XV 402 'A' Low-viz scheme

402



Red crosses outlined  
in white on black

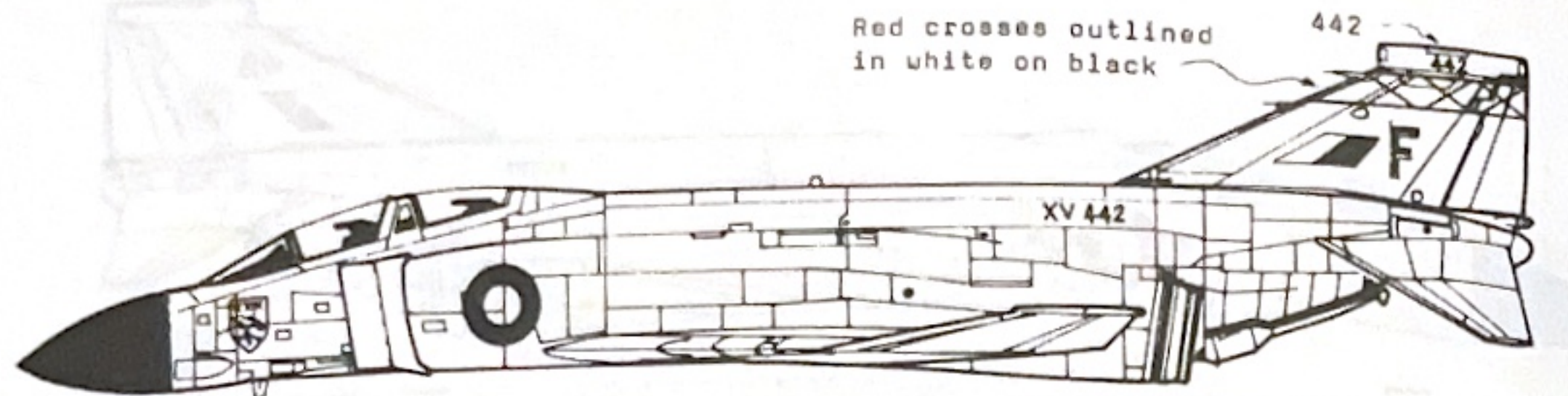

Red Crosses on white background

FGR.2 29 Sqn circa 1981  
XV 442 'F' Standard Camouflage scheme

Squadron badge as above

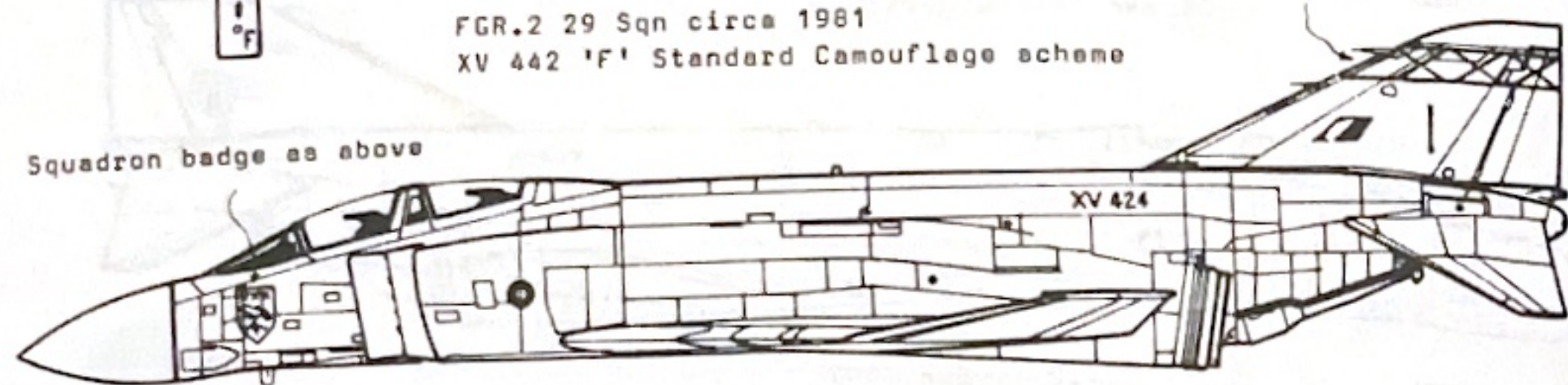

FGR.2 29 Sqn circa 1982  
XV 424 'I' Low-viz scheme

Black serial

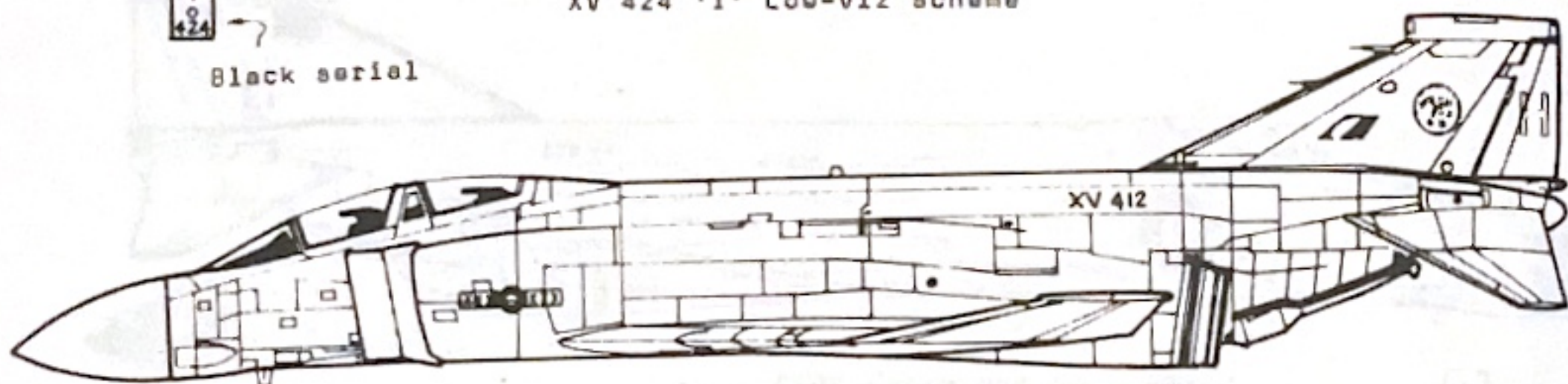

FGR.2 29 Sqn circa 1984  
XV 412 'H' Low viz scheme

Solid yellow star

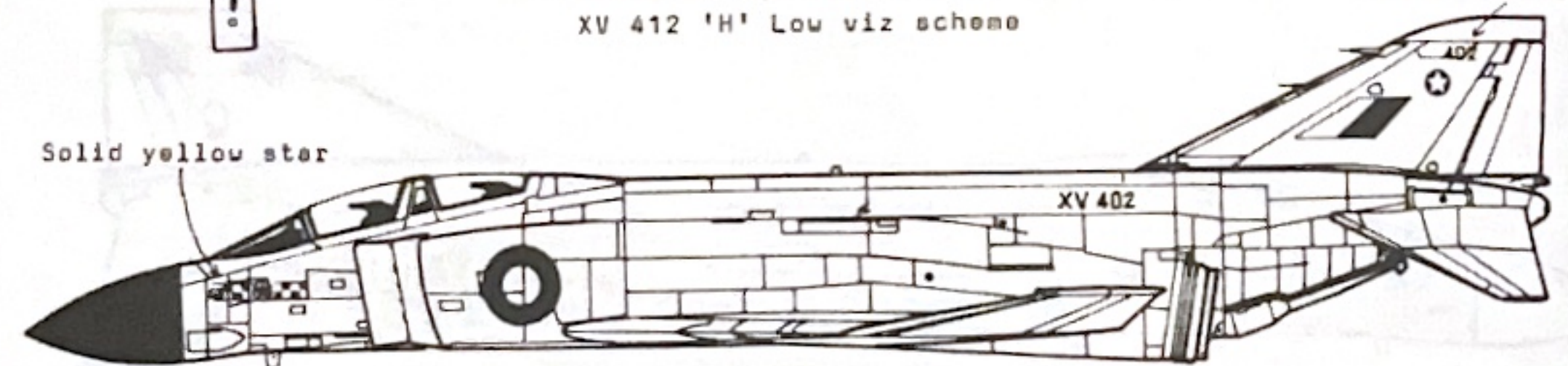

FGR.2 31 Sqn  
XV 402 Standard Camouflage Scheme  
German Rescue markings

'Shadowed' Yellow star

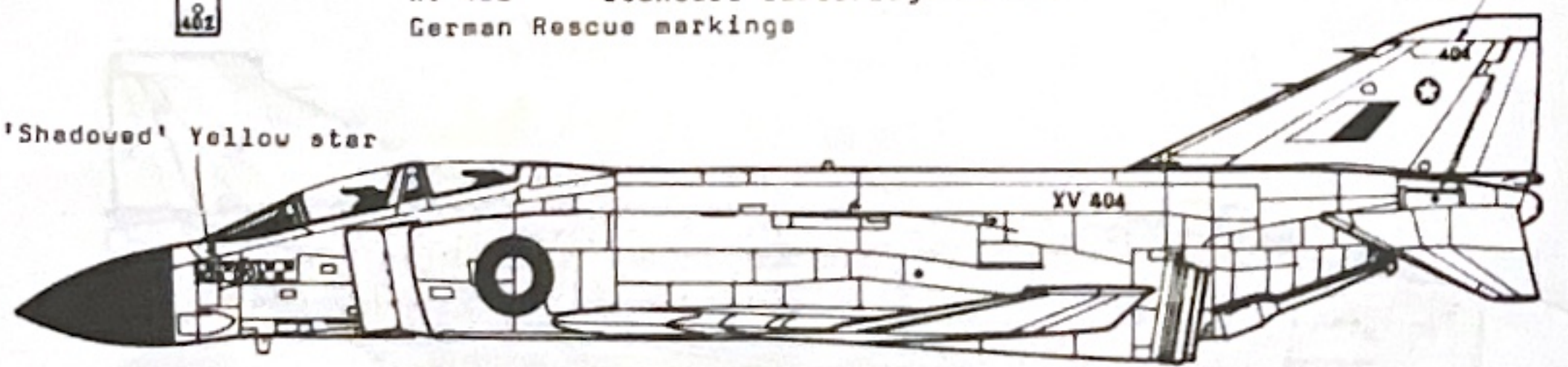

FGR.2 31 Sqn  
XV 404 Standard Camouflage scheme  
German Rescue markings

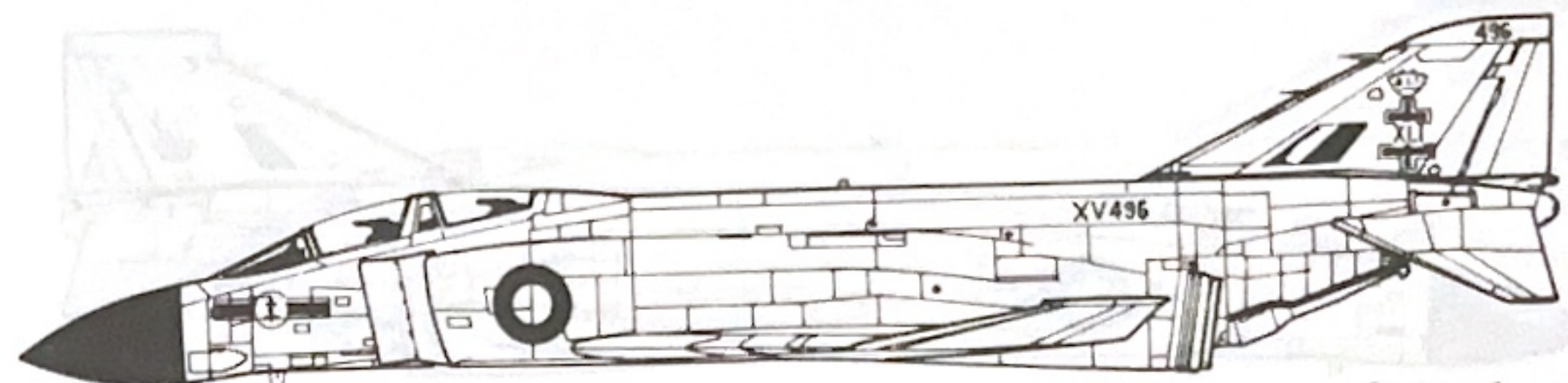

Cockerel on  
white disc

FGR.2 41 Sqn  
XV 496 Standard Camouflage scheme

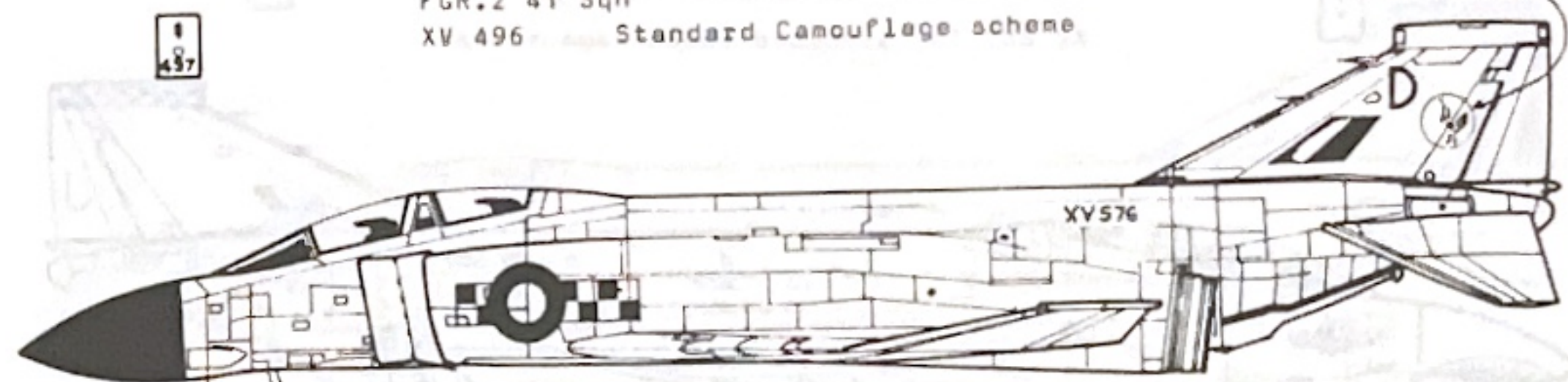

FG.1 43 Sqn 1978  
XV 576 'D' Standard Camouflage scheme

Non-standard roundel  
and flesh

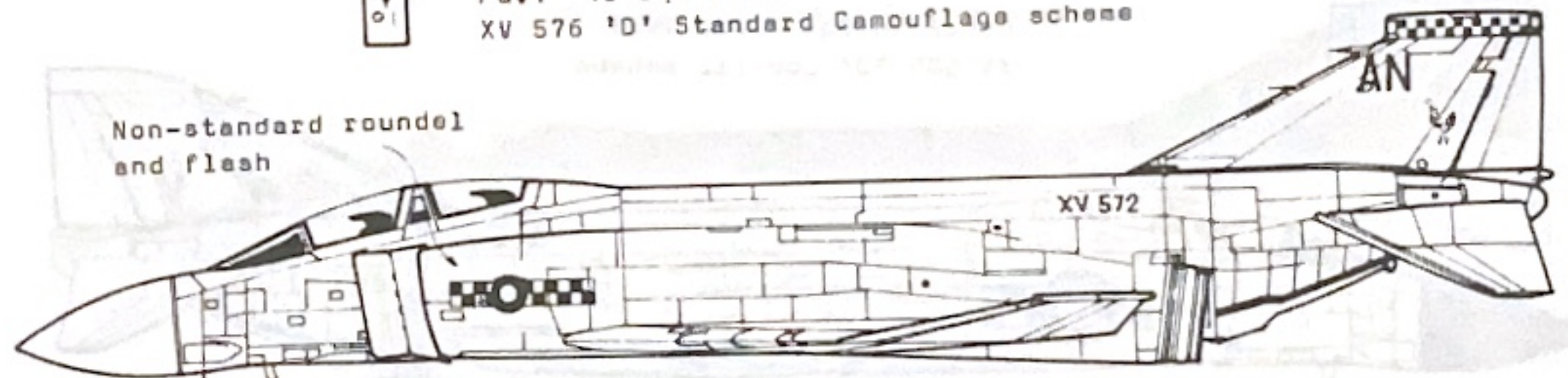

FG.1 43 Sqn 1987  
XV 572 'AN' Low viz scheme

Non-standard roundel  
and flesh

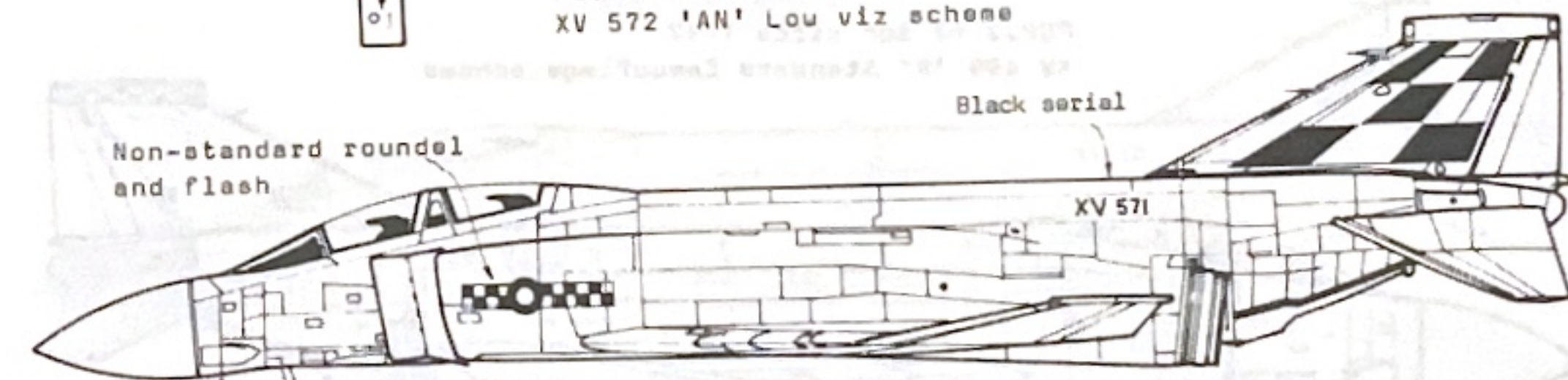

FG.1 43 Sqn C.O.'s special  
XV 571 Low viz scheme

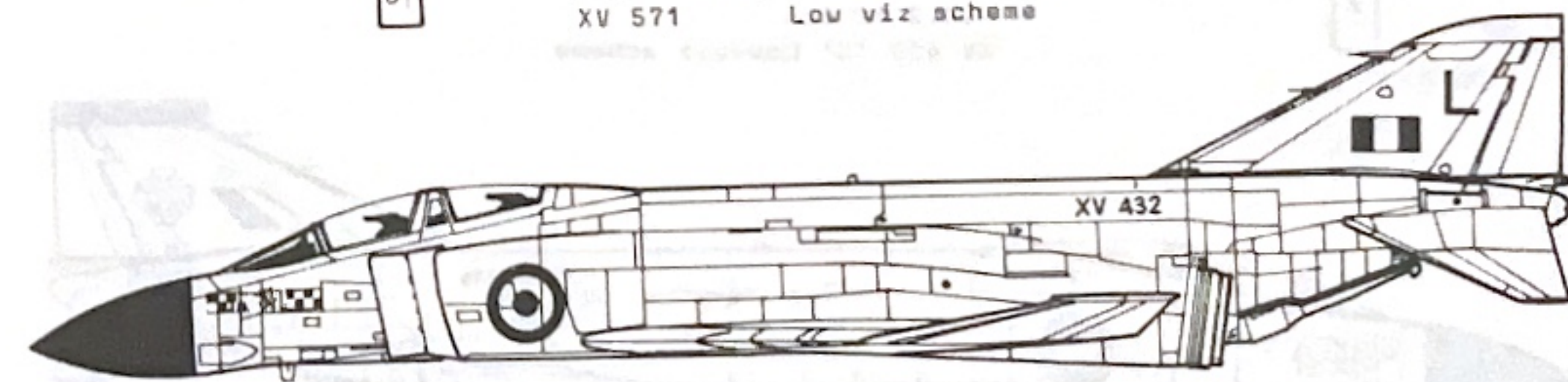

FGR.2 54 Sqn circa 1971  
XV 432 'L' Standard Camouflage scheme High-viz roundels



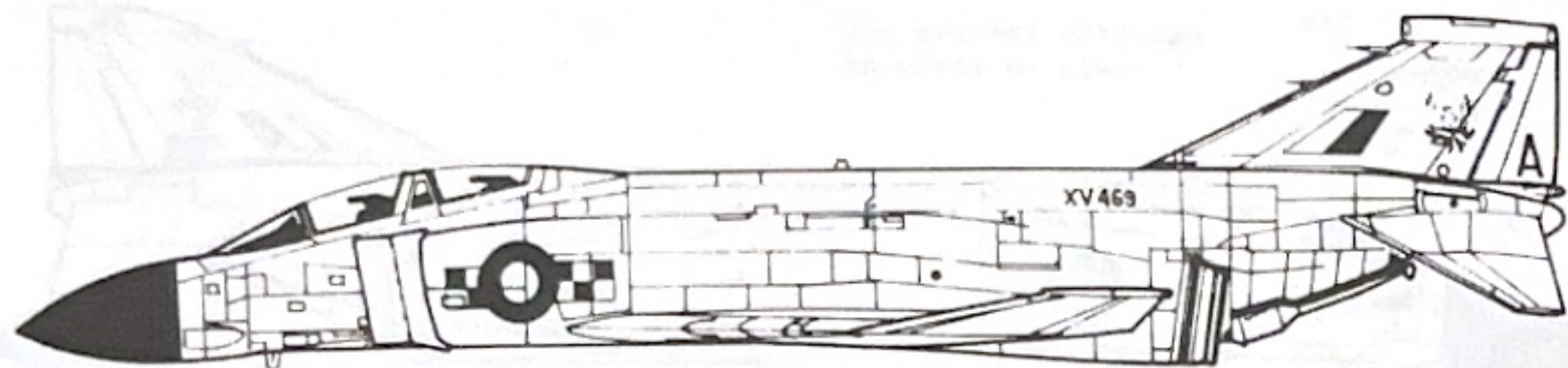

FGR.2 56 Sqn circa 1979  
XV 469 'A' Standard Camouflage scheme

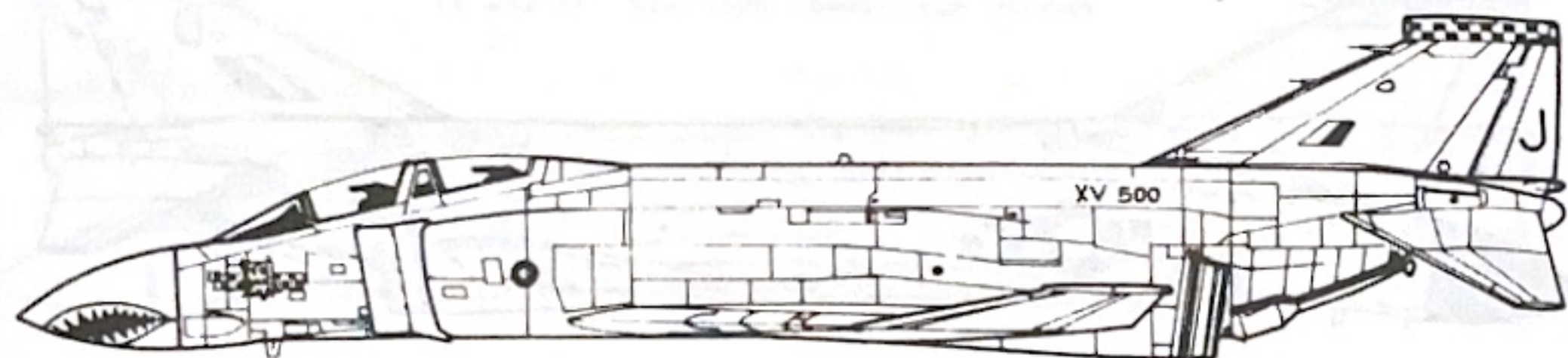

FGR.2 56 Sqn circa 1984  
XV 500 'J' Low-viz scheme

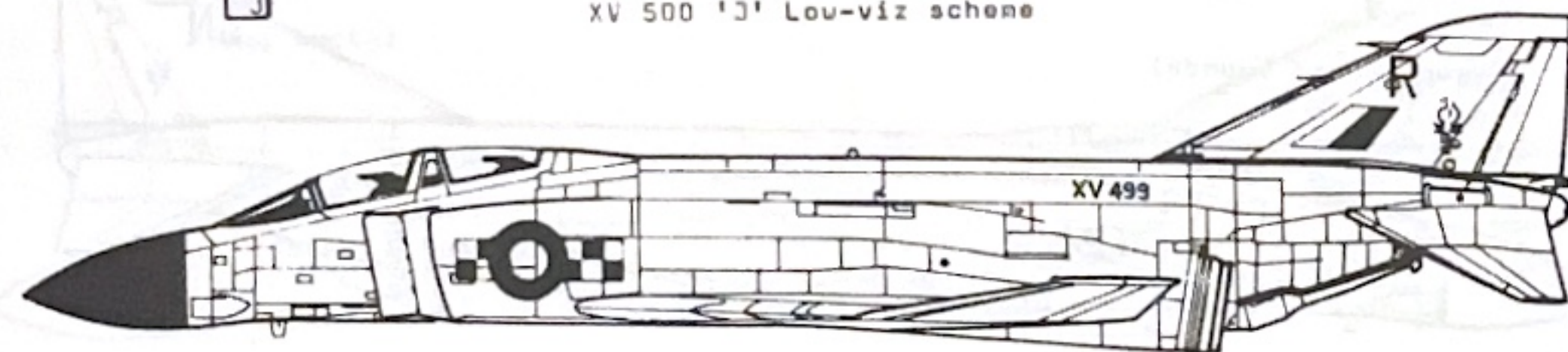

FGR.2 92 Sqn circa 1977  
XV 499 'R' Standard Camouflage scheme

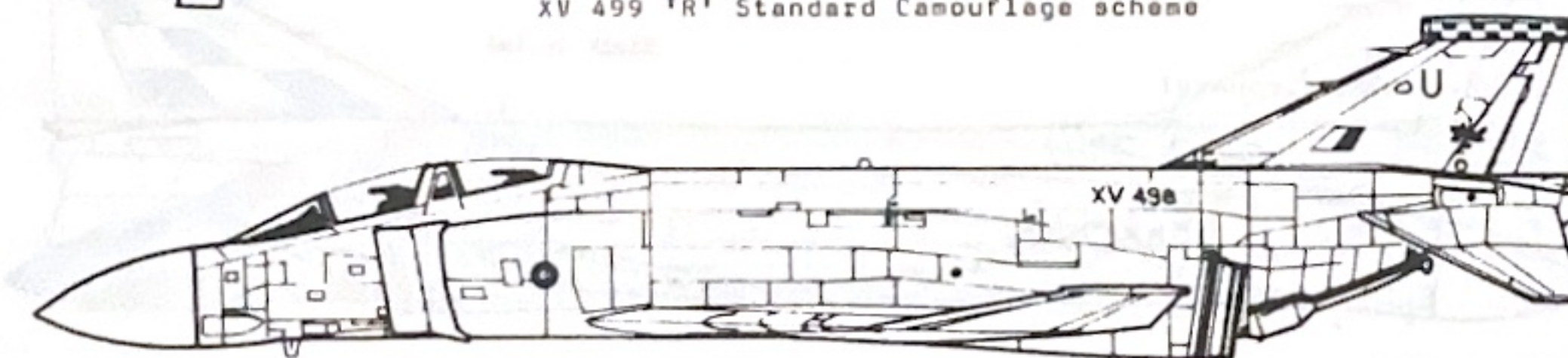

FGR.2 92 Sqn  
XV 498 'U' Low-viz scheme

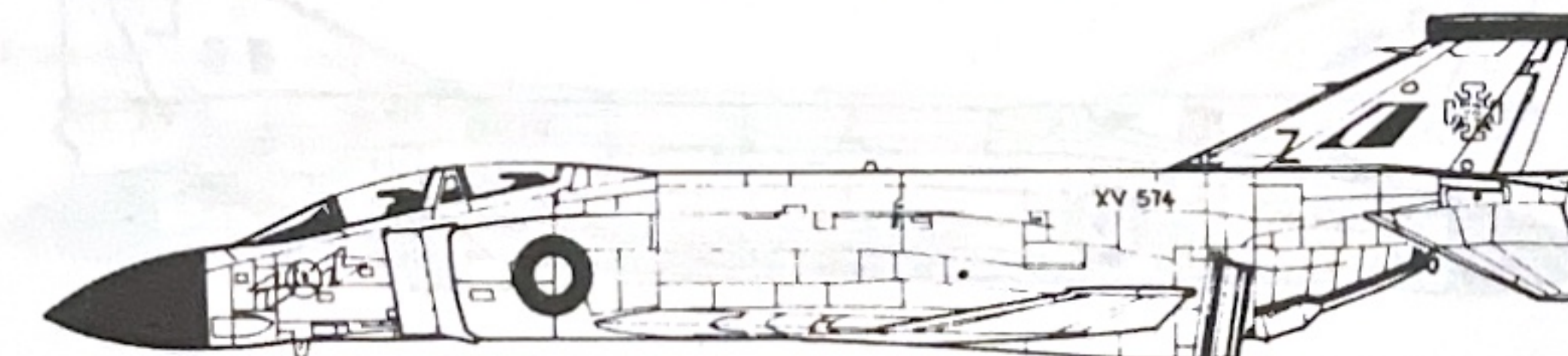

FG.1 111 Sqn  
XV 574 'Z' Standard Camouflage scheme

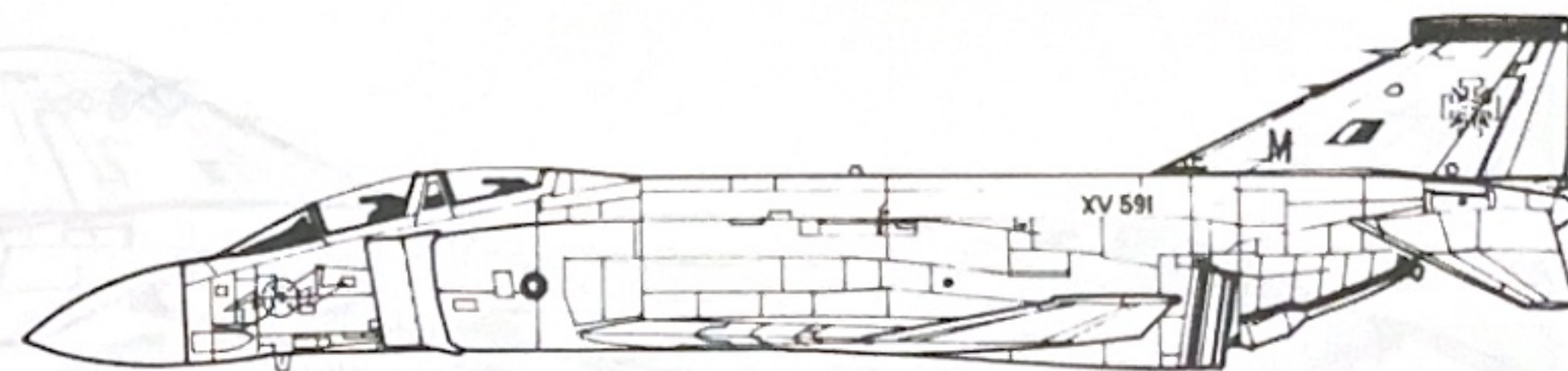

FG.1 111 Sqn circa 1982  
XV 591 'M' Low-viz scheme

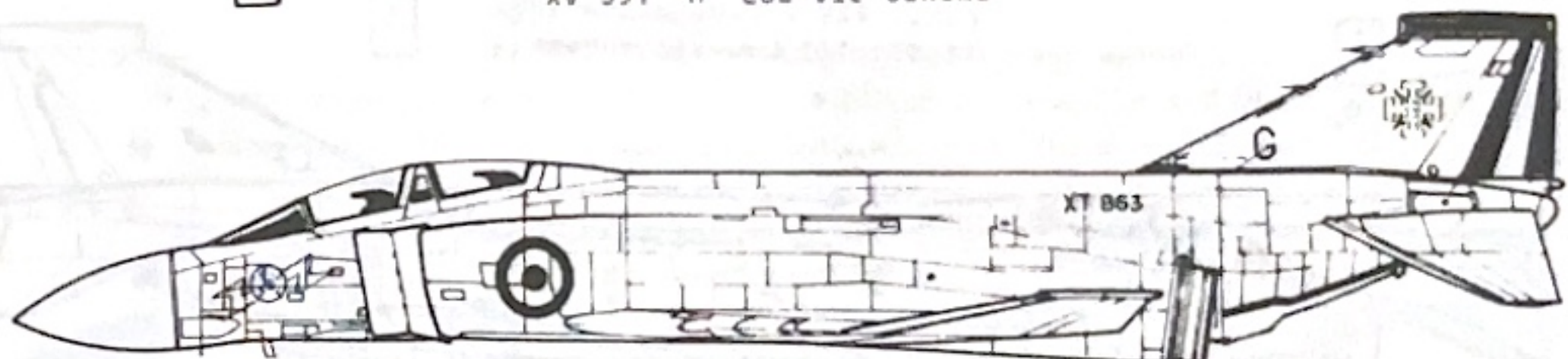

FG.1 111 Sqn 1983  
XT 863 'G' Low-viz scheme  
High-viz roundels, Rudder stripes

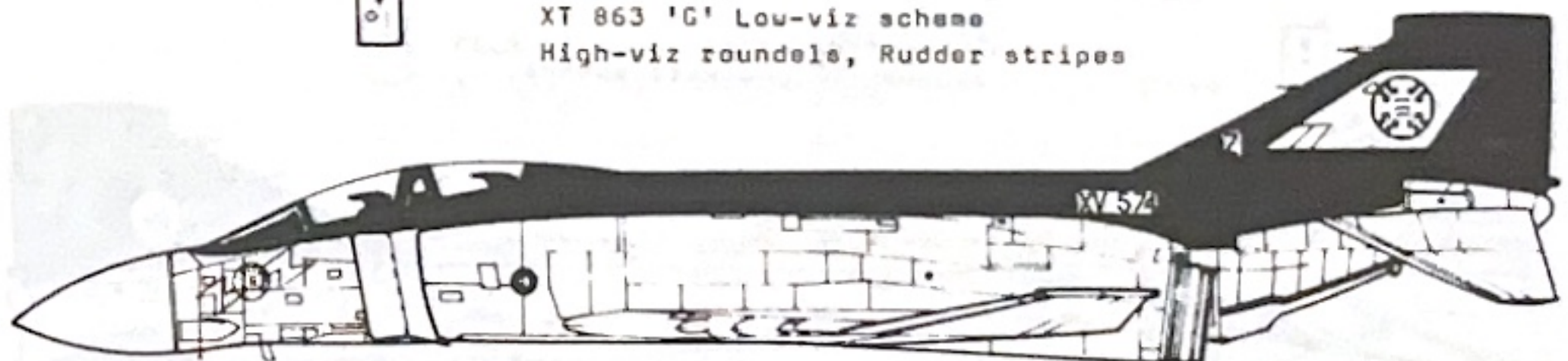

FG.1 111 Sqn circa 1986  
XV 574 'Z' Low-viz scheme  
Black tail and spine

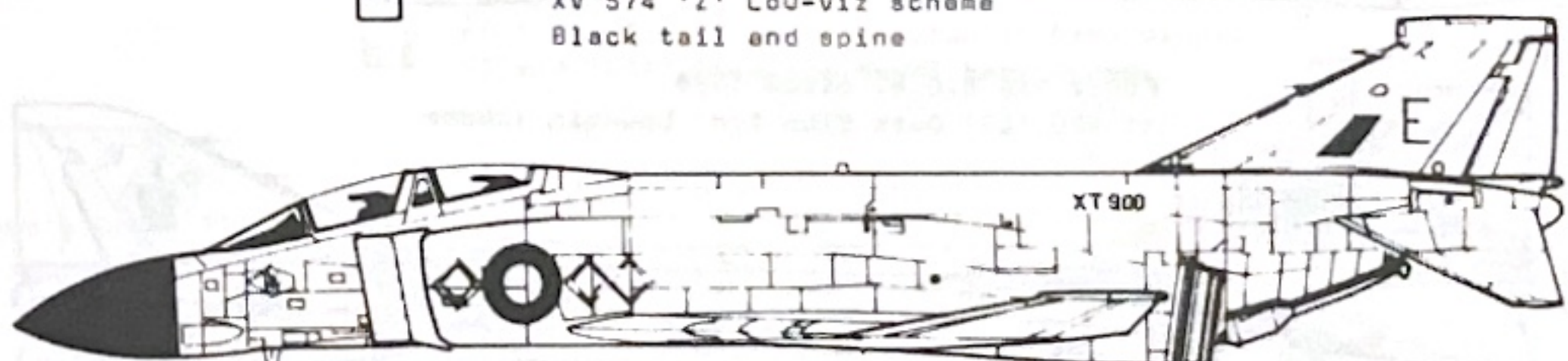

FGR.2 228 O.C.U. circa 1982  
XT 900 'C' Standard Camouflage scheme

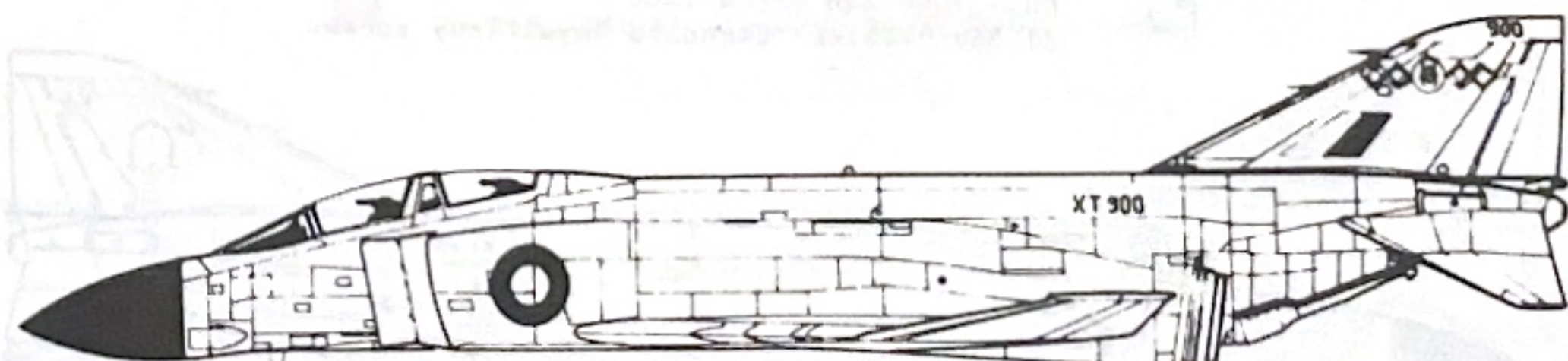

FGR.2 228 O.C.U. circa 1969  
XT 900 Standard Camouflage scheme



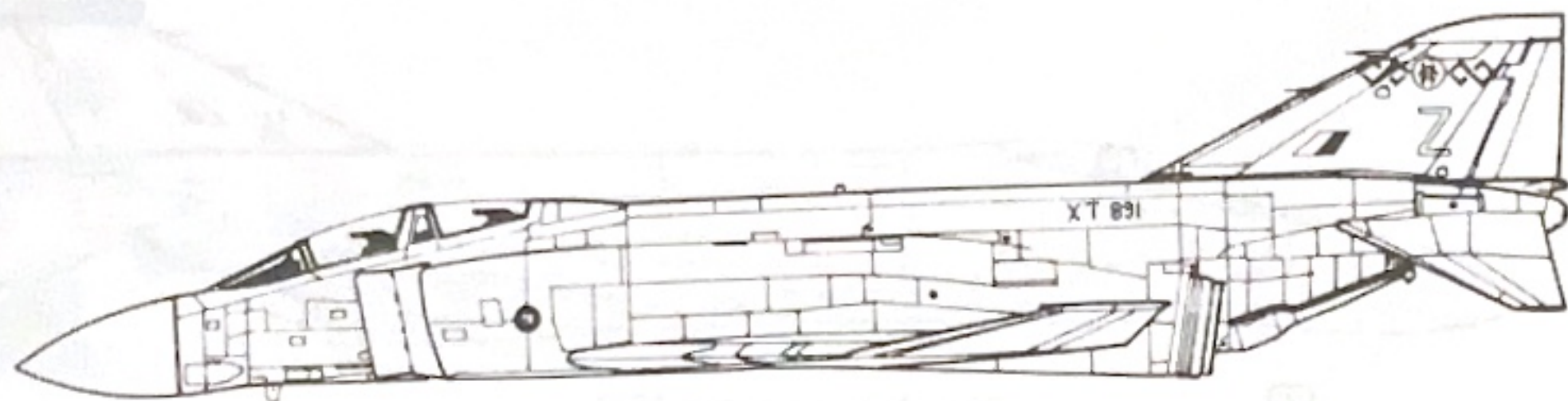

FGR.2 228 D.C.U. circa 1982  
XT 891 'Z' Low-viz scheme

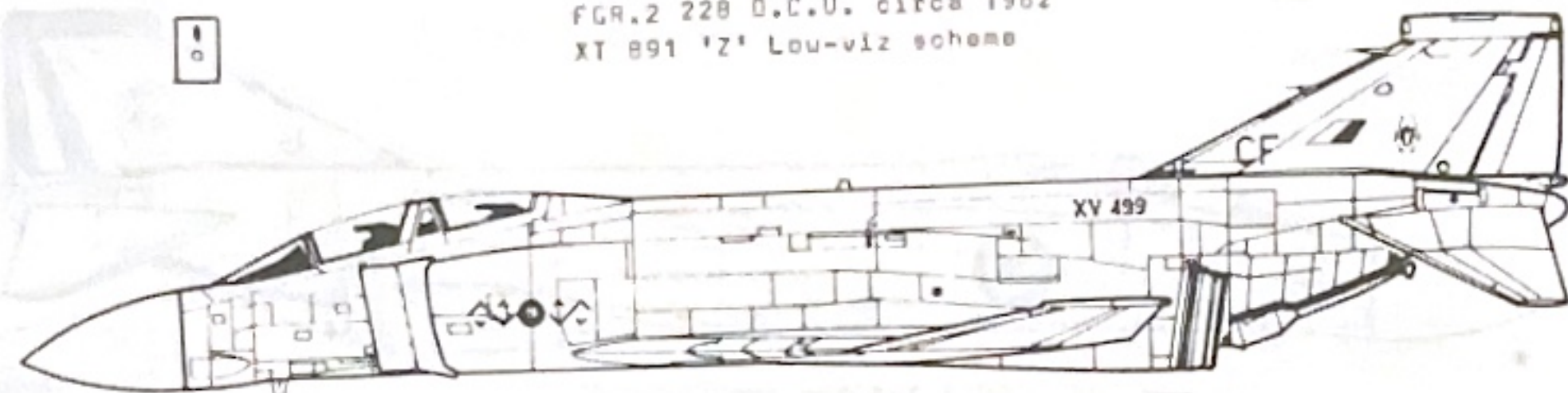

FGR.2 228 D.C.U.  
XV 499 'CF' Low-viz scheme

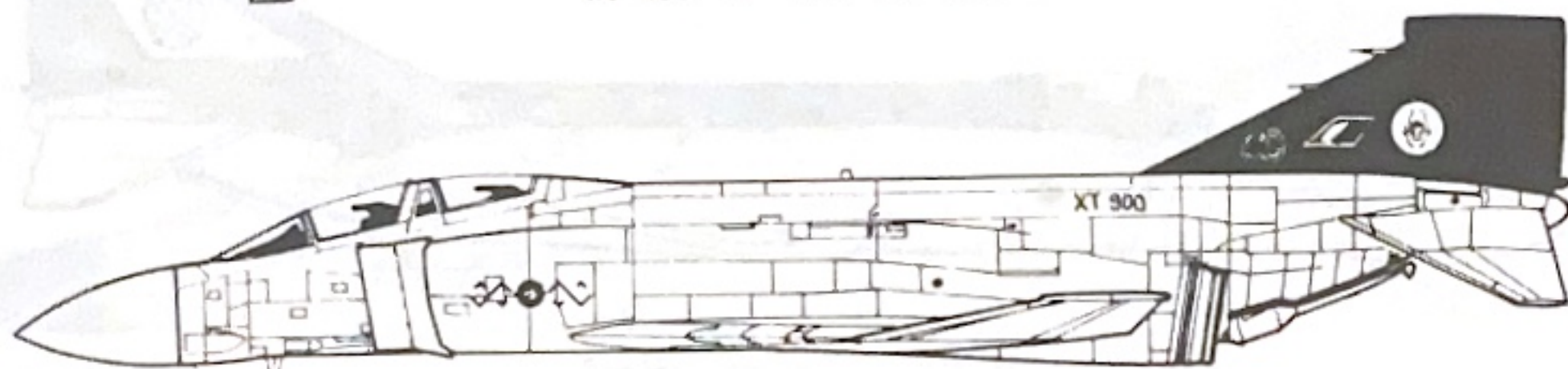

FGR.2 228 D.C.U. circa 1988  
XT 900 'CO' Dark Blue fin Low-viz scheme

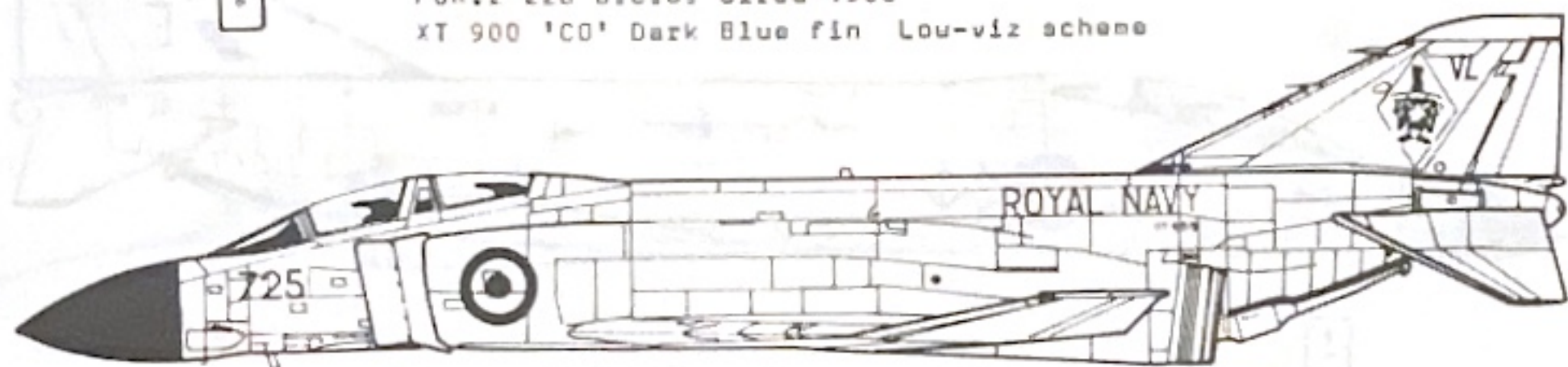

FG.1 700P Sqn circa 1968  
XT 859 '725:VL' Standard Royal Navy scheme

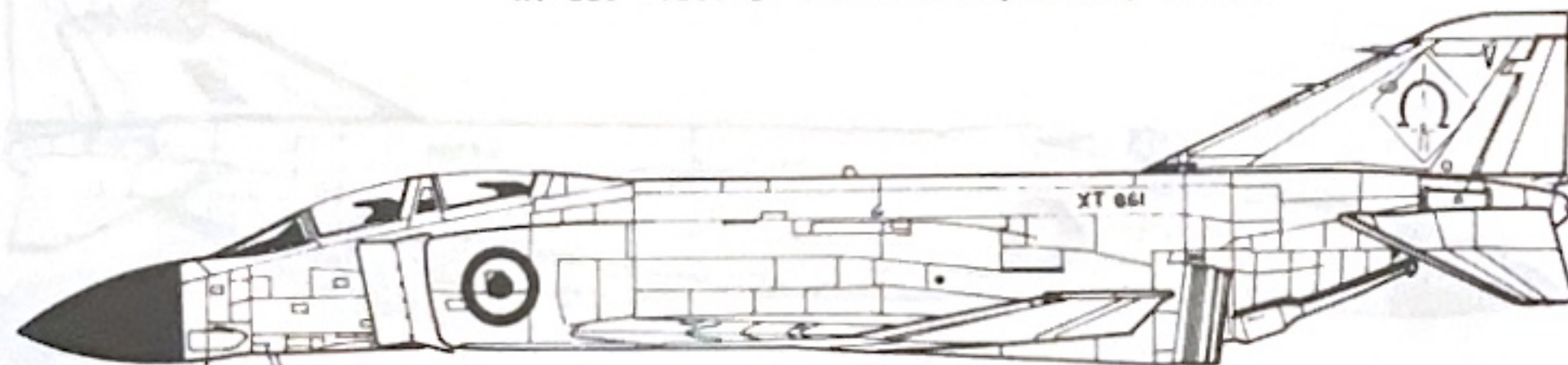

FG.1 Phantom Training Flight  
XT 861 'V' Standard Royal Navy scheme  
without 'Royal Navy' titles

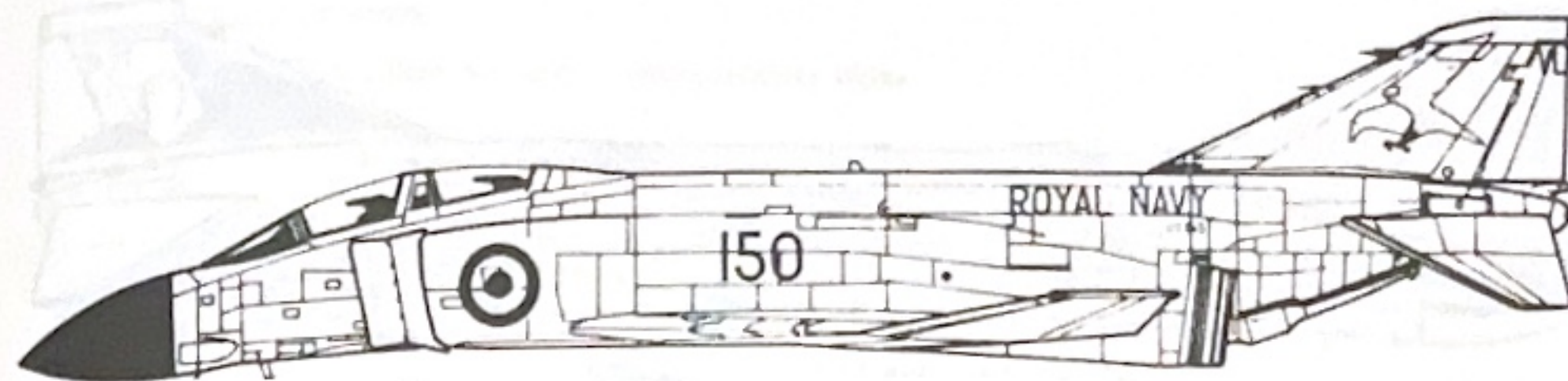

FG.1 767 Sqn  
XT 863 '150' Standard Royal Navy scheme

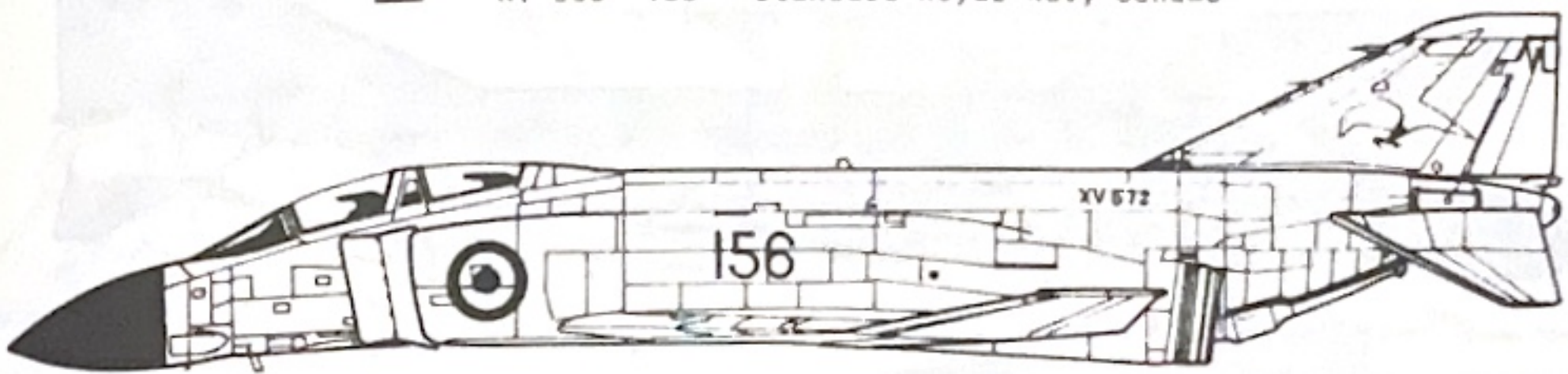

FG.1 767 Sqn (on loan from RAF)  
XV 572 '156' Standard RAF Camouflage scheme

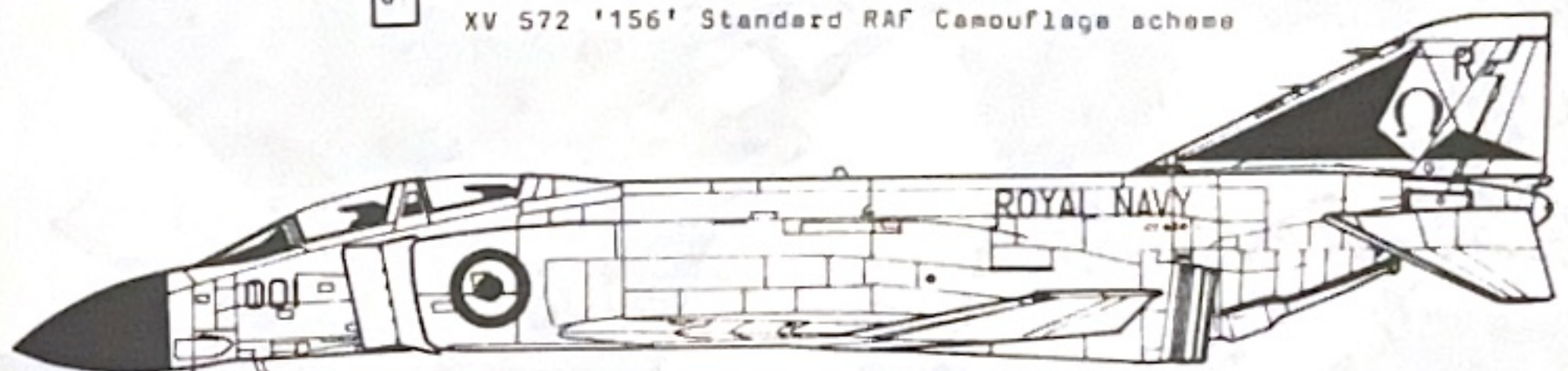

FG.1 892 Sqn (1969 Transatlantic Race Winner)  
XT 858 '001' Standard Royal Navy scheme

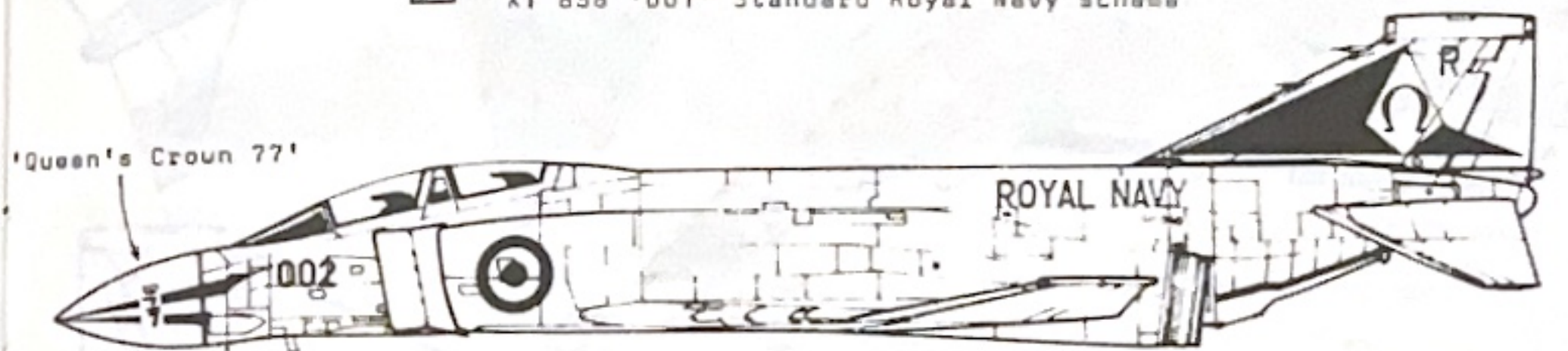

FG.1 892 Sqn (1977 Jubilee scheme - Queen's Crown)  
XV 568 '002:R' Standard Royal Navy scheme

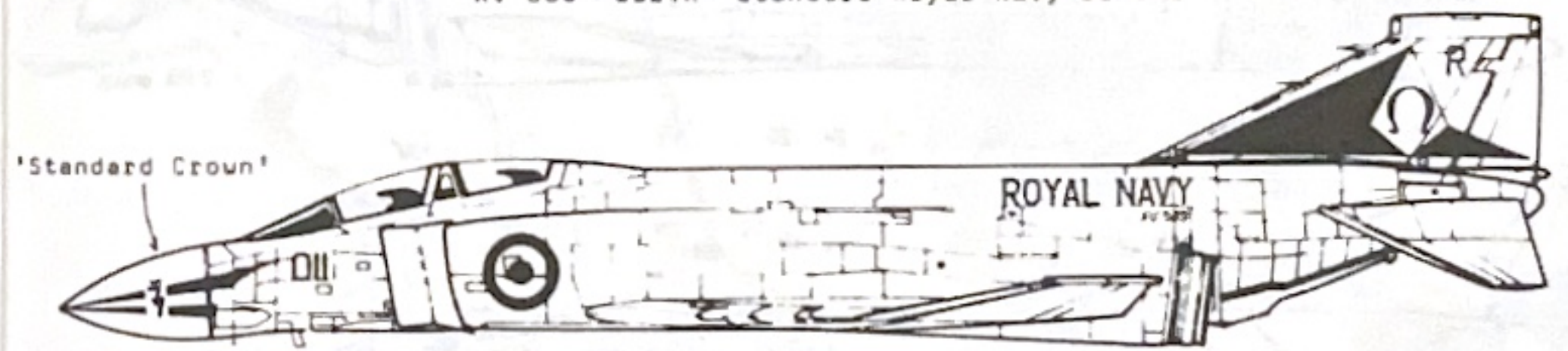

FG.1 892 Sqn (1977 Jubilee scheme)  
XV 589 '011' Standard Royal Navy scheme



Squadron Badge & Flash

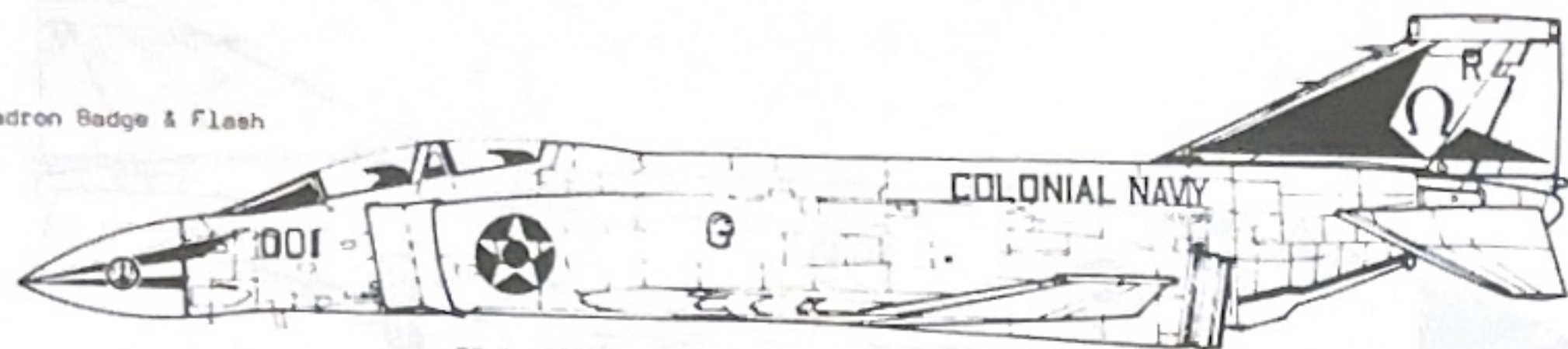

FG.1 892 Sea circa 1975

XV 590 '001.R' Standard Royal Navy Scheme  
'Colonial' replaces 'Royal'

Note early US Navy style roundels on fuselage

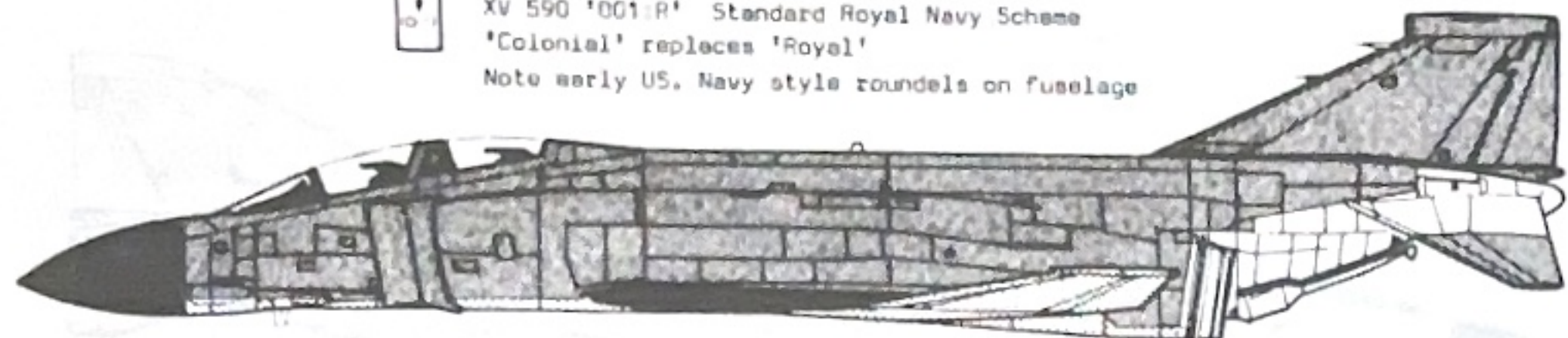

Upper surfaces: Harlequin Grey, Medium Sea Grey

Undersurfaces: Light Aircraft Grey

ROYAL AIR FORCE LOW-VIZ SCHEME

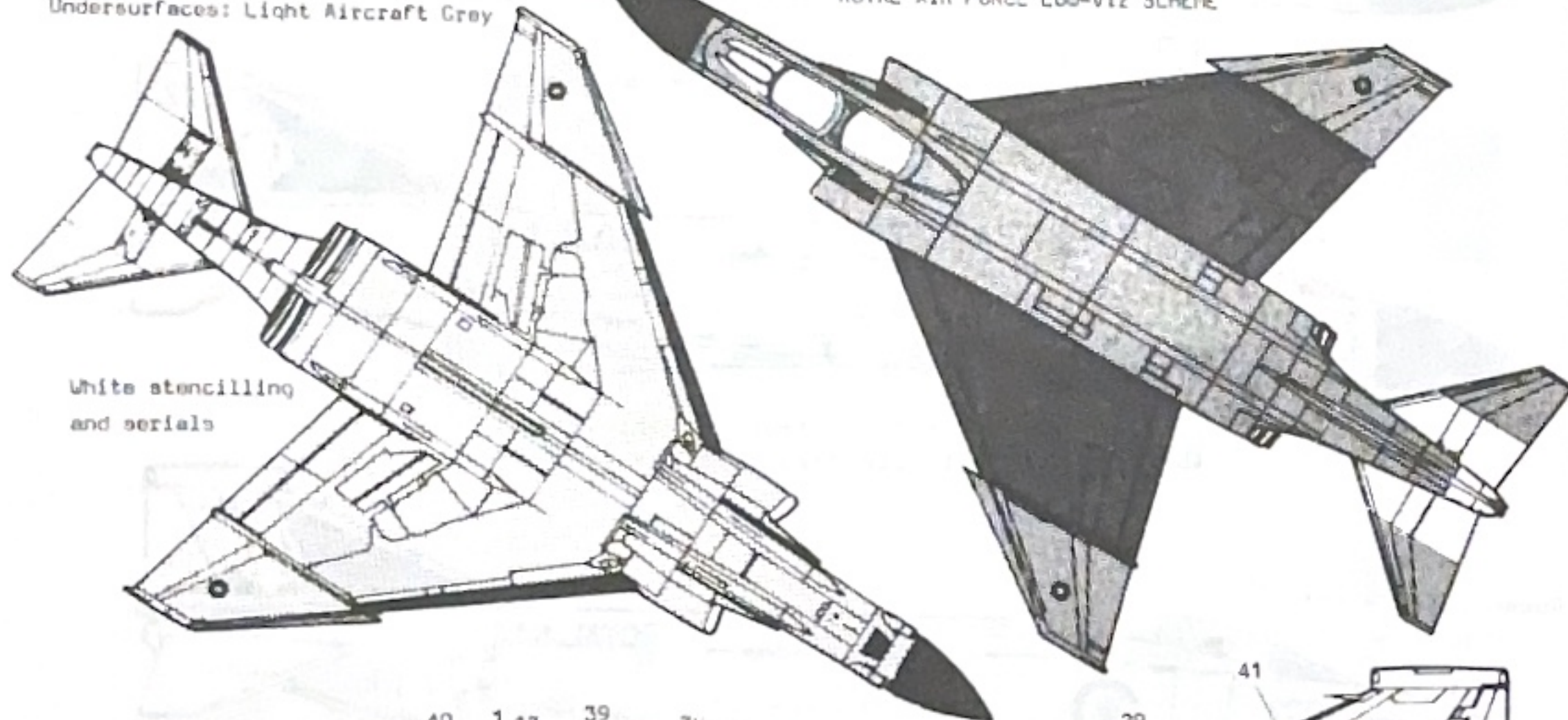

White stencilling  
and serials

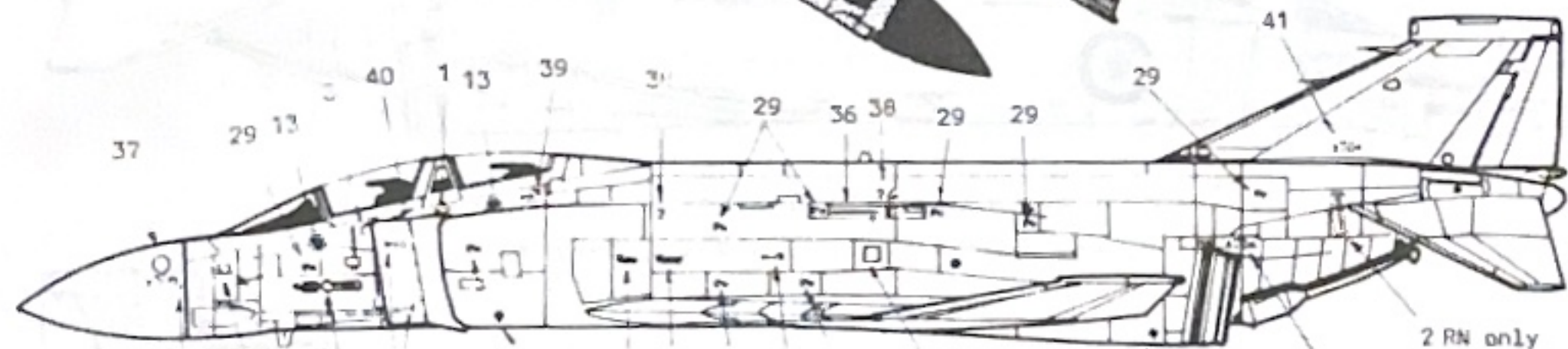

2 RN only

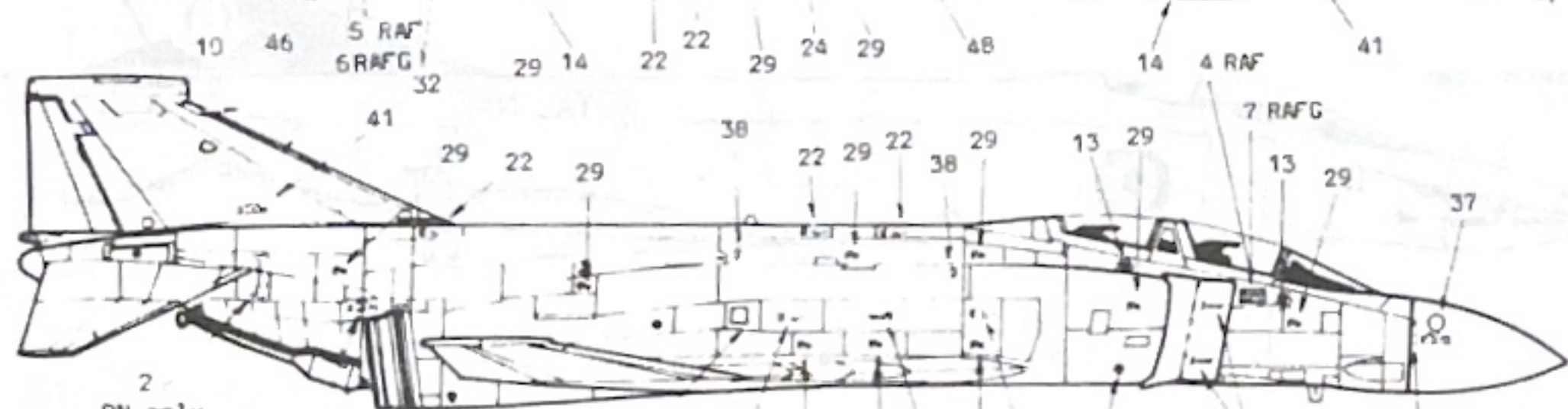

2  
RN only

ROYAL NAVY COLOUR SCHEME

Upper surfaces: Extra Dark Sea Grey Undersurfaces: White

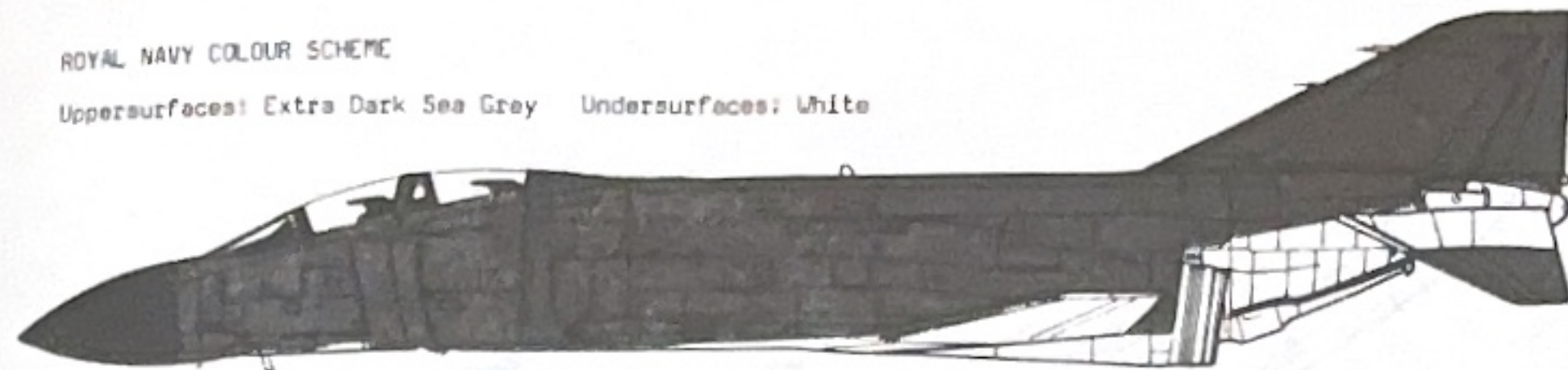

Black stencilling

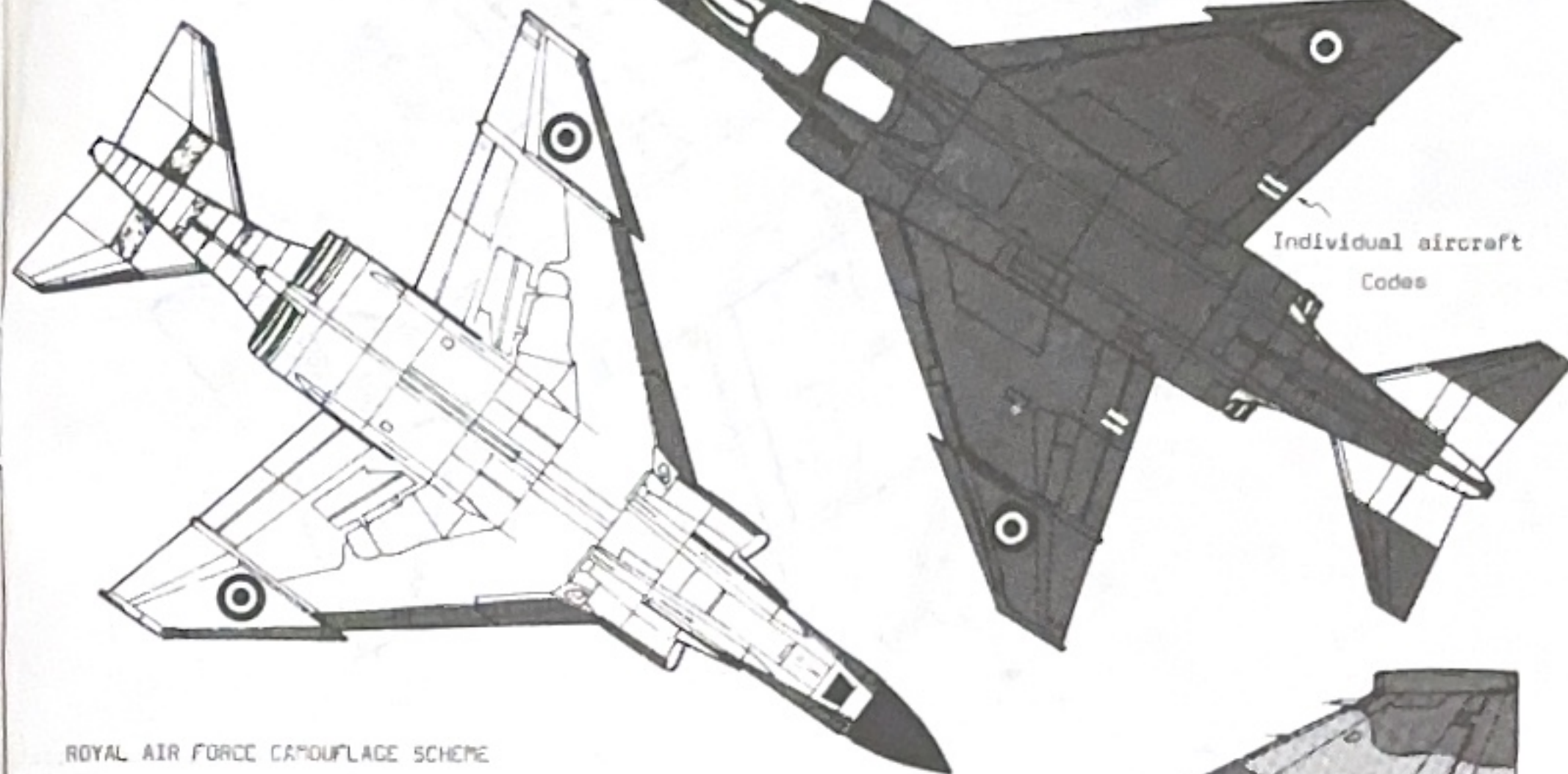

Individual aircraft  
Codes

ROYAL AIR FORCE CAMOUFLAGE SCHEME

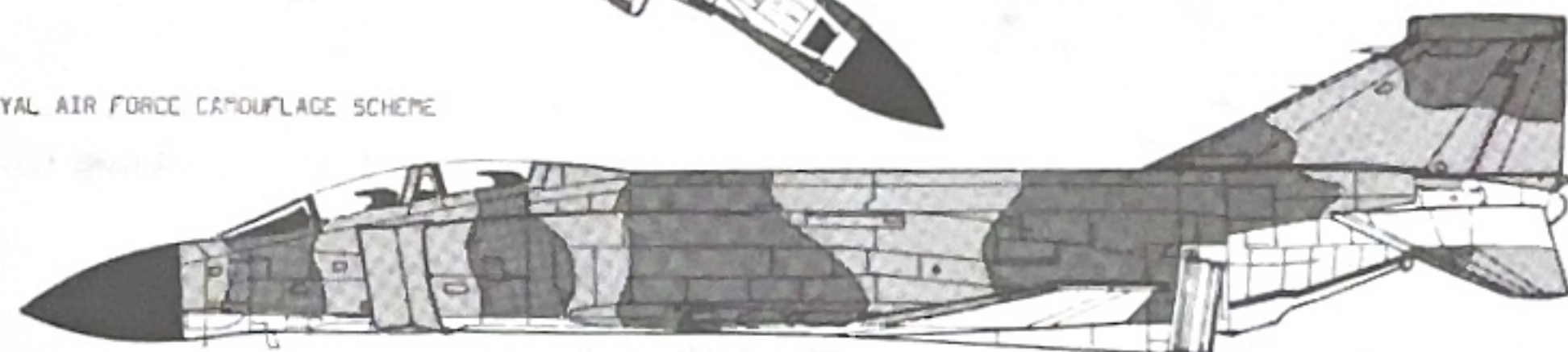

Black stencilling and serials

Upper surfaces: Dark Green; Dark Sea Grey

Undersurfaces: Light Aircraft Grey

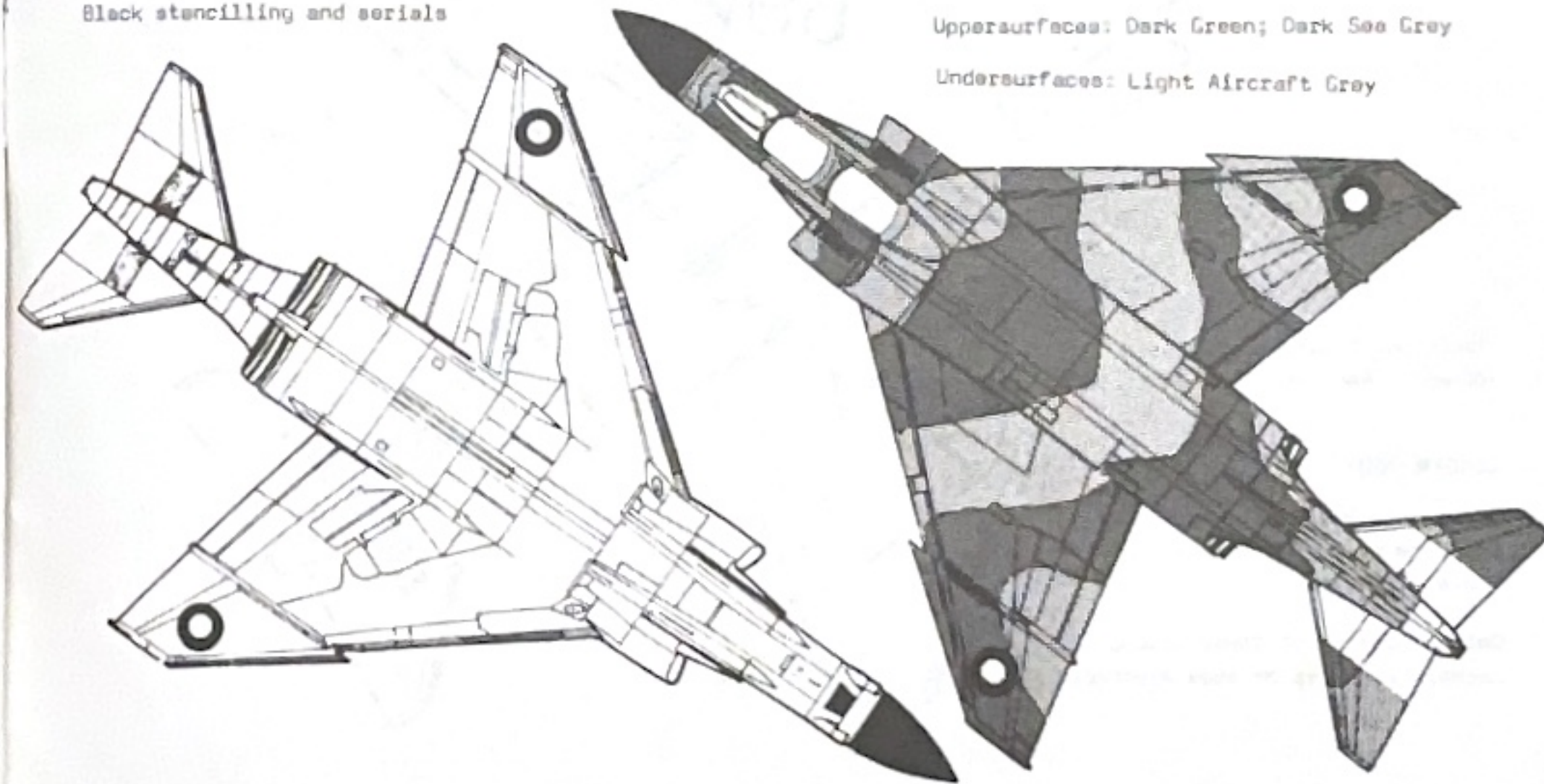



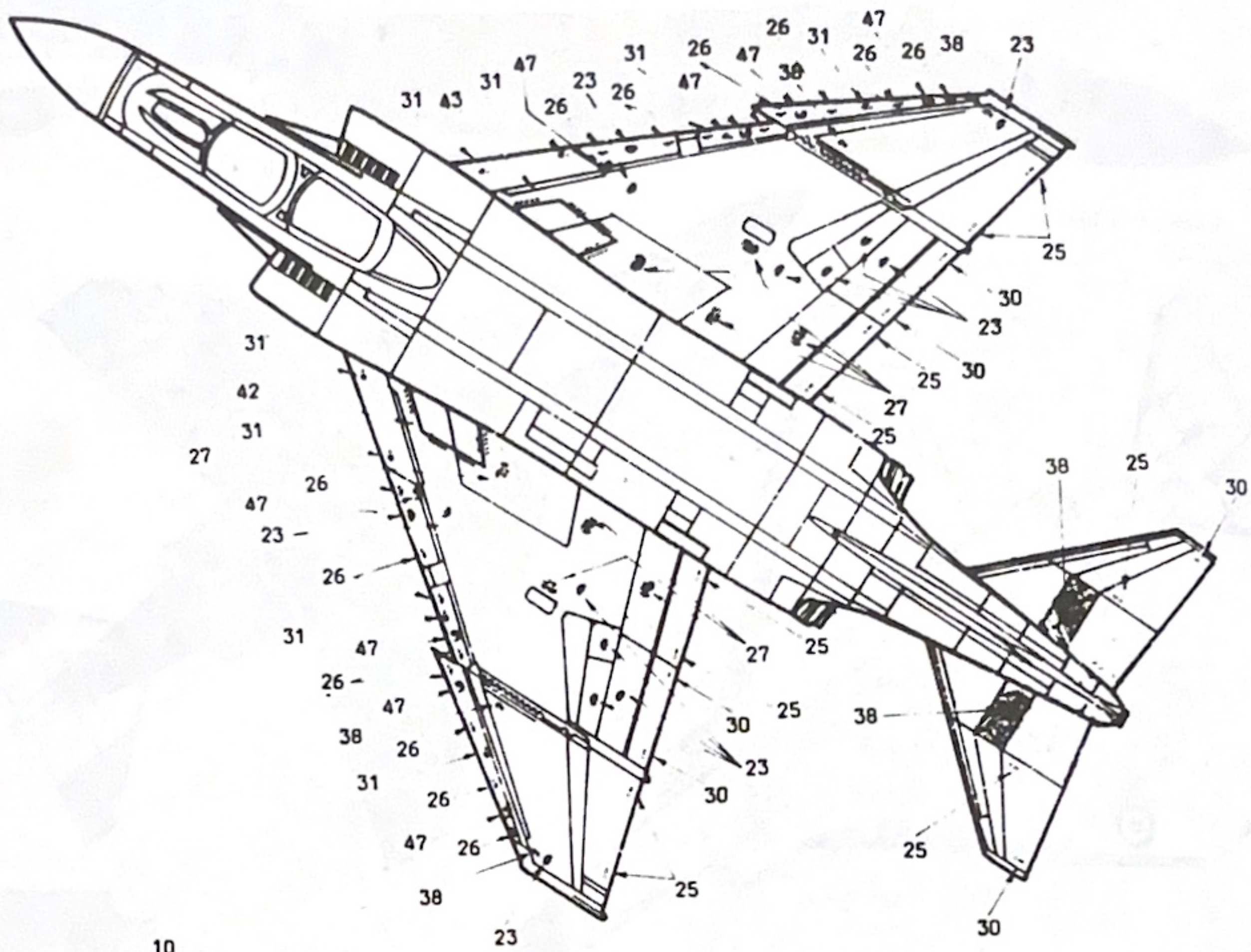

Designed & Drawn by Peter Hazleton  
 MAINTRACK PRODUCTIONS 1988

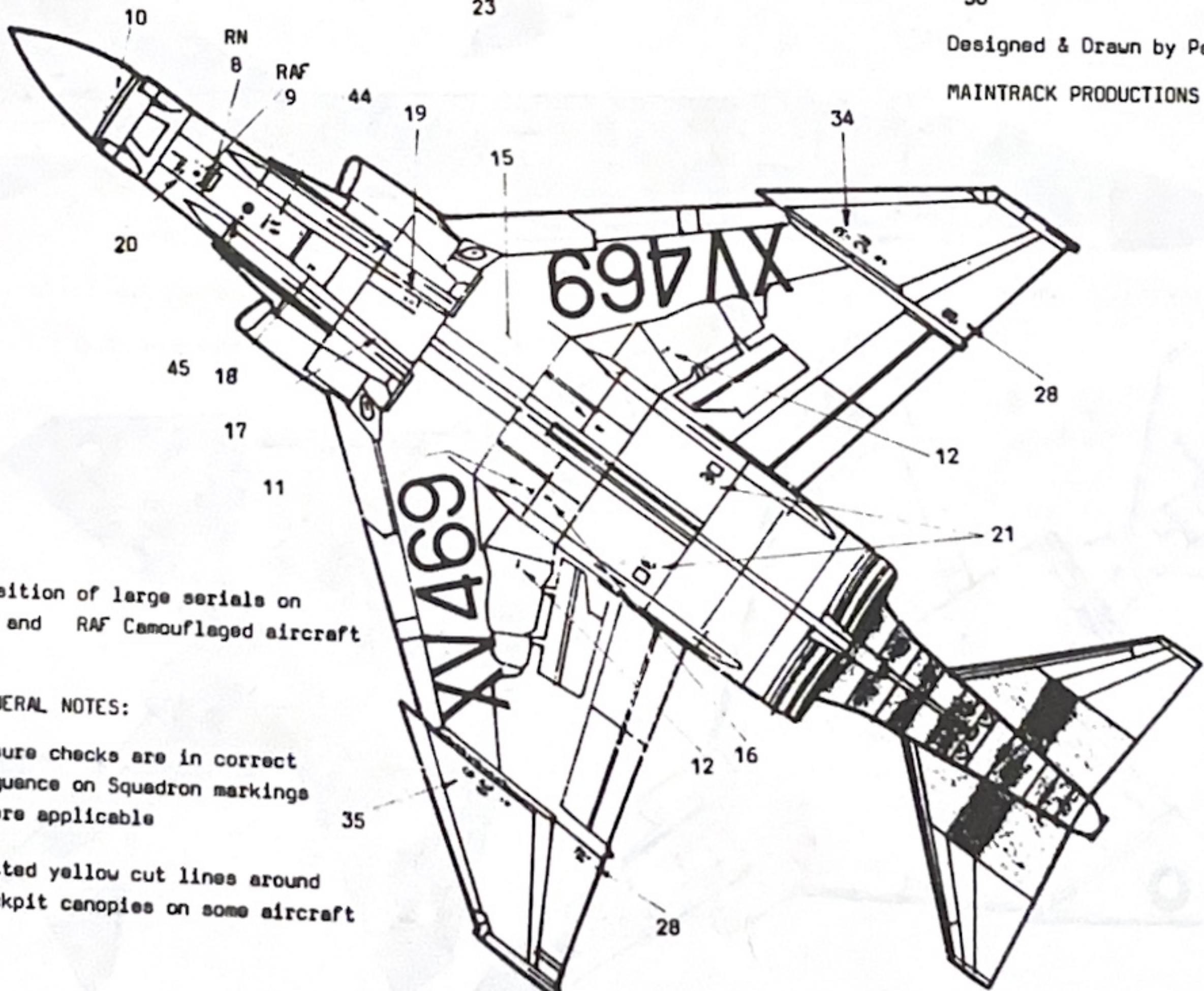

Position of large serials on  
 RN and RAF Camouflaged aircraft

GENERAL NOTES:

Ensure checks are in correct  
 sequence on Squadron markings  
 where applicable

Dotted yellow cut lines around  
 cockpit canopies on some aircraft