

Revell VOLVO 760 GLE

H-7292-0389

©1988 BY REVELL INC.

PRINTED IN W. GERMANY

DEUTSCH: ACHTUNG: Vor dem Zusammensetzen die Bauanleitung gut durchlesen. Jedes Teil ist nummeriert. Reihenfolge der Montageschritte beachten. Benötigte Werkzeuge: Messer und Feile zum Entfernen und Entgraten der Teile. Gummiband, Klebeband und Wäscheklammern zum Zusammenhalten der geklebten Einzelteile. Plastikteile in einer milden Waschlösung reinigen und an der Luft trocknen, damit der Farbanstrich und die Abziehbilder besser haften. Vor dem Ankleben prüfen, ob die Teile passen; Klebstoff sparsam auftragen. Chrom und Farbe an den Klebeflächen entfernen. Kleine Teile anstreichen, bevor sie vom Rahmen entfernt werden. Farben gut durchtrocknen lassen, erst dann den Zusammenbau fortsetzen. Jedes Abziehbildmotiv einzeln ausschneiden und ca. 20 Sekunden in warmes Wasser tauchen. Das Motiv an der bezeichneten Stelle vom Papier abschleiben und mit Lösspapier andrücken.

ENGLISH: ATTENTION: Carefully read instruction sheet before assembling. Each part is numbered. Consider succession of assembly steps. Required tools: knife and file to remove and trim parts; rubber band, adhesive tape and clothes pegs to hold parts after cementing. Wash plastic in mild detergent solution, rinse and let air dry for better paint and decal adhesion. Scrape chrome and paint at area to be glued. Paint small parts on runner before removing. Allow paint to dry thoroughly before continuing assembly. Cut out each decal one by one and dip it in warm water for approx. 20 secs.; slide decal from the paper at the marked position and dab with blotting-paper.

FRANÇAIS: ATTENTION: lire soigneusement la fiche d'instructions avant d'assembler. Chaque pièce est numérotée. Suivre la succession des étapes de montage. Outils nécessaires: couteau et lime pour détacher et ébarber les pièces, élastiques, papier adhésif et pinces à linge pour maintenir ensemble les pièces après collage. Laver le plastique dans une solution détergente légère, rincer et laisser sécher à l'air libre pour une meilleure adhérence de la peinture et des décalés. Ajuster les pièces ensemble avant de coller. Employer la colle Revell pour plastique exclusivement. Utiliser très peu de colle à chaque fois. Gratter le chrome ou la peinture sur les surfaces à coller. Peindre les petites pièces sur le support avant de les détacher. Laisser la peinture sécher totalement avant de continuer l'assemblage. Découper chaque décalé séparément et le plonger dans l'eau chaude environ 20 secondes. Faire glisser le décalé du papier à l'endroit du décor et tamponner avec du papier buvard.

NEDERLANDS: OPGELET: alvorens te beginnen met het in elkaar zetten, eerst de handleiding goed doorlezen. Elk onderdeel is genummerd. Aandacht besteden aan de volgorde van montage. Het benodigde gereedschap: mesje en vijl voor het verwijderen en het afbramen van de onderdelen, elastiek, plakband en wasknijpers gebruiken voor het bij elkaar houden van de gelijnde onderdelen. De plastic onderdelen met een zacht wasmiddel schoonmaken en laten drogen zodat de verf en de transfers beter hechten. Alvorens te lijmen, eerst vaststellen of de onderdelen

passen; de lijm zuinig opbrengen. Chrom en verf van de op elkaar te lijmen delen verwijderen. Kleine onderdelen verven vóór deze van het gietraam verwijderd worden. De verf goed laten drogen en eerst dan verder gaan met de bouw. Elk transfer apart uitknippen en ca. 20 seconden in lauw/warm water leggen. Het transfer op de juiste plaats van het papier schuiven op het model en met vloeipapier aandrukken.

SVENSKA: VIKTIGT: Läs noggrant igenom instruktionerna innan du börjar bygga. Varje del är numrerad. Tänk igenom ordningsföljden för de olika momenten. Följande verktyg krävs: kniv och fil för att ta loss och putsa detaljerna, gummiband, tejp och klädnypon för att hålla detaljerna på plats medan limmet torkar. Tvätta alla plastdetaljerna i mild tvålösning, skölj och låt lufttorka för att få färg och dekalerna att fästa bättre. Proppassa alltid detaljerna innan du limmar. Använd endast Revells plastlim. Använd sparsamt med lim. Skrapa bort krom och färg från den yta som ska limmas: måla smådetaljerna innan du skär loss dem. Låt all färg torka ordentligt innan du fortsätter byggandet. Skär ut varje dekal för sig och blöt den i ljust varmt vatten i ungefär 20 sekunder, och låt dekalen glida av papperet och ner på det markerade läget: sug sedan försiktigt upp det mesta vattnet med löspapper eller en tygtrasa.

ITALIANO: Attenzione: Leggere attentamente le istruzioni prima dell'assemblaggio. Ogni pezzo è numerato. Tener presente la successione delle fasi di assemblaggio. Attrezzi necessari: coltello e lima per rimuovere e rifinire le parti elastiche nastro adesivo e spilli per tenere le parti dopo averle incollate. Lavare la plastica con un detergente delicato, sciacquare e lasciar asciugare all'aria per una migliore adesione della vernice e delle 'decal'. Accoppiare le parti da incollare. Usare solamente 'Revell plastic cement'. Usare poco collante. Grattare la cromatura e la vernice nei punti da incollare. Dipingere i piccoli accessori sul supporto prima di rimuoverli. Far seccare bene la vernice prima di continuare nell'assemblaggio. Ritagliare una per una le 'decal' ed immergerle in acqua tiepida per circa 20 secondi. Applicare ogni 'decal' nella posizione segnata e tamponare con della carta assorbente.

ESPAÑOL: ATENCIÓN: cuidadosamente lean la hoja de instrucciones antes del montaje. Cada pieza es numerada, consideren la sucesión de las operaciones de montaje. Herramientas requeridas: cuchilla y lima para quitar y desbarbar las piezas, banda de caucho, cinta adhesiva y pinzas para sujetar las piezas, después de engomarlas. Lavar el plástico en solución detergente suave, aclarar y dejar que se seque al aire para una mejor adhesión de la pintura y la calcomanía. Adaptar las piezas bien juntas antes de encolar. Solamente utilizar pegamento plástico Revell. Utilizar el pegamento cuidadosamente y sin exceso. Raspar el cromado y la pintura en la zona que ha de ser encolada: Pintar las piezas pequeñas giratorias antes de sacarlas. Dejar que la pintura se seque totalmente antes de continuar el montaje. Cortar cada calcomanía una por una y sumergirla en agua caliente durante aproximadamente 20 segundos. Deslizar la calcomanía del papel en la posición marcada y golpearla suavemente con el papel secante.



Kleben
Glue
A coller
Lijmen
Limmas
Incollare
Engomar



Nicht kleben.
Don't glue.
A ne pas coller.
Niet lijmen.
Timmas ej.
Non incollare.
No engomar.



Anzahl der Arbeitsgänge.
Number of working steps.
Nombre d'étapes de travail
Het aantal der bouwhandelingen.
Antal arbetsmoment.
Numero di passaggi.
Numero de operaciones de trabajo.



Wahlweise
Optional
Facultatif
Ter keuze
Vallritt
Facoltativo
Opcional

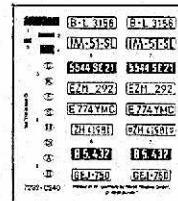

Abziehbild in Wasser einweichen und anbringen.
Soak and apply decals.
Mouiller et appliquer les décalés.
Transfer in water even laten weken en opbrengen.
Biedt and fast dekalerna.
Immergere in acqua ed applicare decal.
Remojar y aplicar las calcomanías.



Abbildung zusammengebauter Teile.
Shown assembled.
Vu assemblé.
Afbeelding van een gebouwd onderdeel.
Visas hopsatt.
Figura ensamblada.
Presentado montado.



Klarsichtteile
Clear parts
Pièces transparentes
Transparente onderdelen
Genomskinliga detaljer
Parte trasparente
Limpiar las piezas

A METALLIC GREY EISENFARBIG 01 GRIS METALLIQUE IJZERKLEUR JARRINGRA FERRO	B FIERY RED FEUERROT 31 ROUGE VERMILLON VURROOD ROSSO ACCESO	C WHITE WEISS 301 BLANC WIT VIT BIANCO	D GREEN GRÜN 48 VERT GRÖEN GRÖN VERDE	E ALUMINIUM ALUMINIUM 99 ALUMINIUM ALUMINIUM ALUMINIUM ALUMINIUM	F BRASS MESSING 02 CUIVRE JAUNE MESSING MANSING OTTONE	G ORANGE ORANGE 30 ORANGE ORANGE ORANGE ARANCIO
H BLACK SCHWARZ 302 NOIR ZWART SWART NERO	I MATT YELLOW MATT GELB 15 JAUNE MAT MAT GEEL MATT GUL GIALLO SMORTO	1. ALUMINIUM ALUMINIUM 99 ALUMINIUM ALUMINIUM ALUMINIUM ALUMINIUM	2. CLEAR FARBLOS 1 INCOLOR KLEURLOOS KLAR TRANSPARENTE	K MATT BLACK MATT SCHWARZ 8 NOIR MAT MAT ZWART MATT SWART NERO SMORTO	L SILVER SILBER 90 ARGENT ZILVER SILVER ARGENTO	M BLUE BLAU 52 BLEU BLAUW BLA BLU

Sollte es einmal vorkommen, daß ein Teil im Bausatz fehlt, bitte an REVELL PLASTICS GMBH, Postfach 2609+2620, Abteilung X, 4980 Bünde, schreiben und die Bauanleitung, auf der das fehlende Teil angekreuzt ist, mitschicken, sonst können wir keinen Ersatz leisten.

Should you find any missing parts, please write to REVELL PLASTICS GMBH, 2609 + 2620, department X, D-4980 Bünde, W. Germany, and we will send you these as quickly as possible with our compliments. Please indicate clearly with a cross on the instruction leaflet, which piece(s) are missing. Always remember to write your name and address clearly and in full.

Zou het voorkomen, dat er een deel in de bouwdoos ontbreekt, kunt U schrijven naar REVELL PLASTICS GMBH, Postbus 2609 + 2620, Afdeling X, D-4980 Bünde. De bouwbeschrijving waarop het ontbrekende deel aangekruist is, bijsluiten, anders kunnen wij U dit onderdeel niet vergoeden. Vergeet vooral niet Uw naam en adres duidelijk te vermelden.

Pour toute pièce manquante, écrivez à REVELL PLASTICS GMBH, Postbus 2609 + 2620, département X, D-4980 Bünde, et cet élément vous sera aussitôt envoyé et ce, gratuitement. Il vous suffit dans ce cas de marquer d'une croix la pièce manquante sur la feuille d'instruction du modèle choisi. N'oubliez surtout pas d'écrire clairement votre nom et adresse.

10

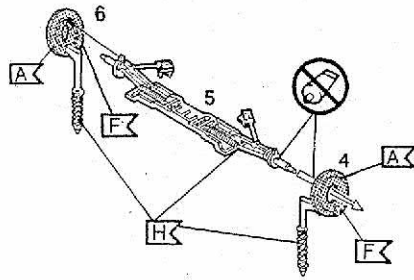



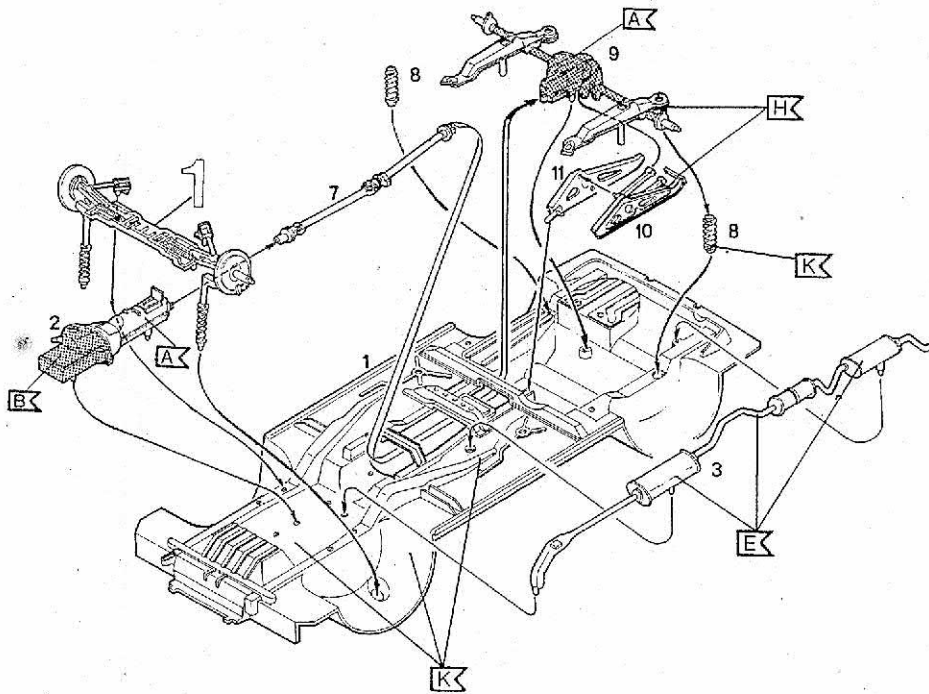



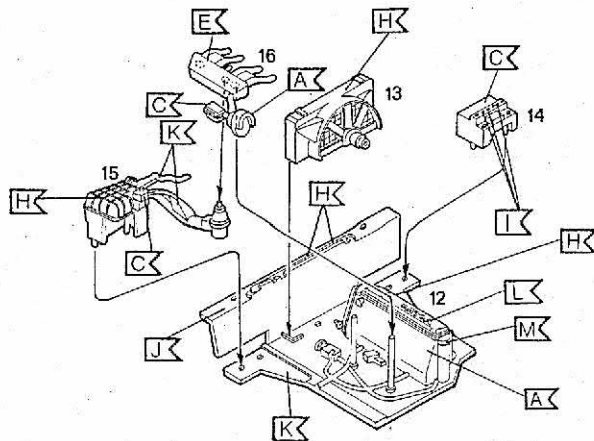

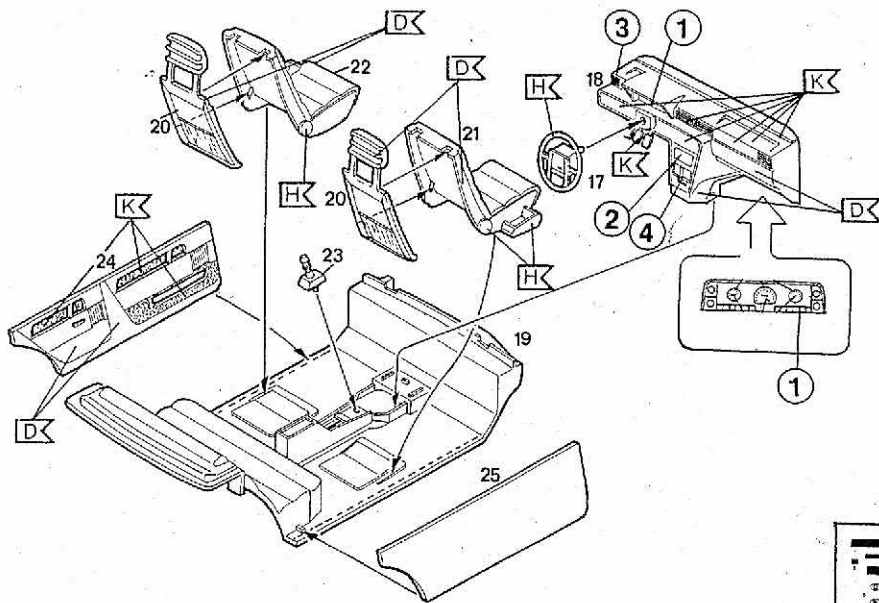







































20





30

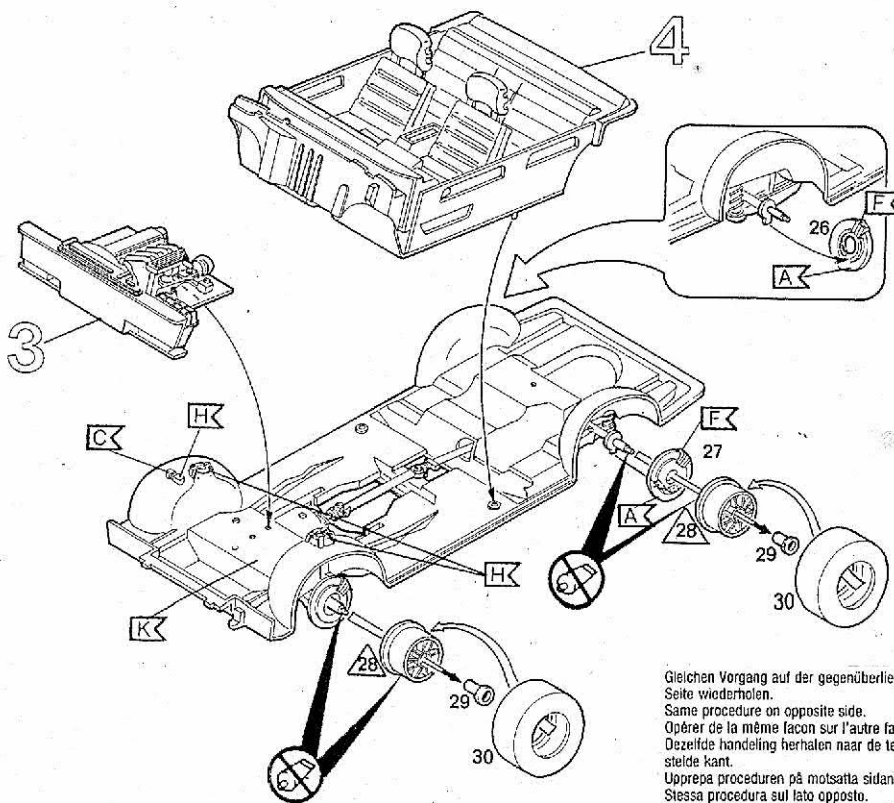

4 

	0-L 3158	0-L 3159
	0-L 3160	0-L 3161
	0-L 3162	0-L 3163
	0-L 3164	0-L 3165
	0-L 3166	0-L 3167
	0-L 3168	0-L 3169
	0-L 3170	0-L 3171
	0-L 3172	0-L 3173
	0-L 3174	0-L 3175
	0-L 3176	0-L 3177
	0-L 3178	0-L 3179
	0-L 3180	0-L 3181
	0-L 3182	0-L 3183
	0-L 3184	0-L 3185
	0-L 3186	0-L 3187
	0-L 3188	0-L 3189
	0-L 3190	0-L 3191
	0-L 3192	0-L 3193
	0-L 3194	0-L 3195
	0-L 3196	0-L 3197
	0-L 3198	0-L 3199
	0-L 3200	0-L 3201
	0-L 3202	0-L 3203
	0-L 3204	0-L 3205
	0-L 3206	0-L 3207
	0-L 3208	0-L 3209
	0-L 3210	0-L 3211
	0-L 3212	0-L 3213
	0-L 3214	0-L 3215
	0-L 3216	0-L 3217
	0-L 3218	0-L 3219
	0-L 3220	0-L 3221
	0-L 3222	0-L 3223
	0-L 3224	0-L 3225
	0-L 3226	0-L 3227
	0-L 3228	0-L 3229
	0-L 3230	0-L 3231
	0-L 3232	0-L 3233
	0-L 3234	0-L 3235
	0-L 3236	0-L 3237
	0-L 3238	0-L 3239
	0-L 3240	0-L 3241
	0-L 3242	0-L 3243
	0-L 3244	0-L 3245
	0-L 3246	0-L 3247
	0-L 3248	0-L 3249
	0-L 3250	0-L 3251

5 

Gleichen Vorgang auf der gegenüberliegenden Seite wiederholen.
 Same procedure on opposite side.
 Opérer de la même façon sur l'autre face.
 Dezelfde handeling herhalen naar de tegenovergestelde kant.
 Upprepa proceduren på motsatta sidan.
 Stessa procedura sul lato opposto.
 Realizar el mismo procedimiento en el lado opuesto.

6

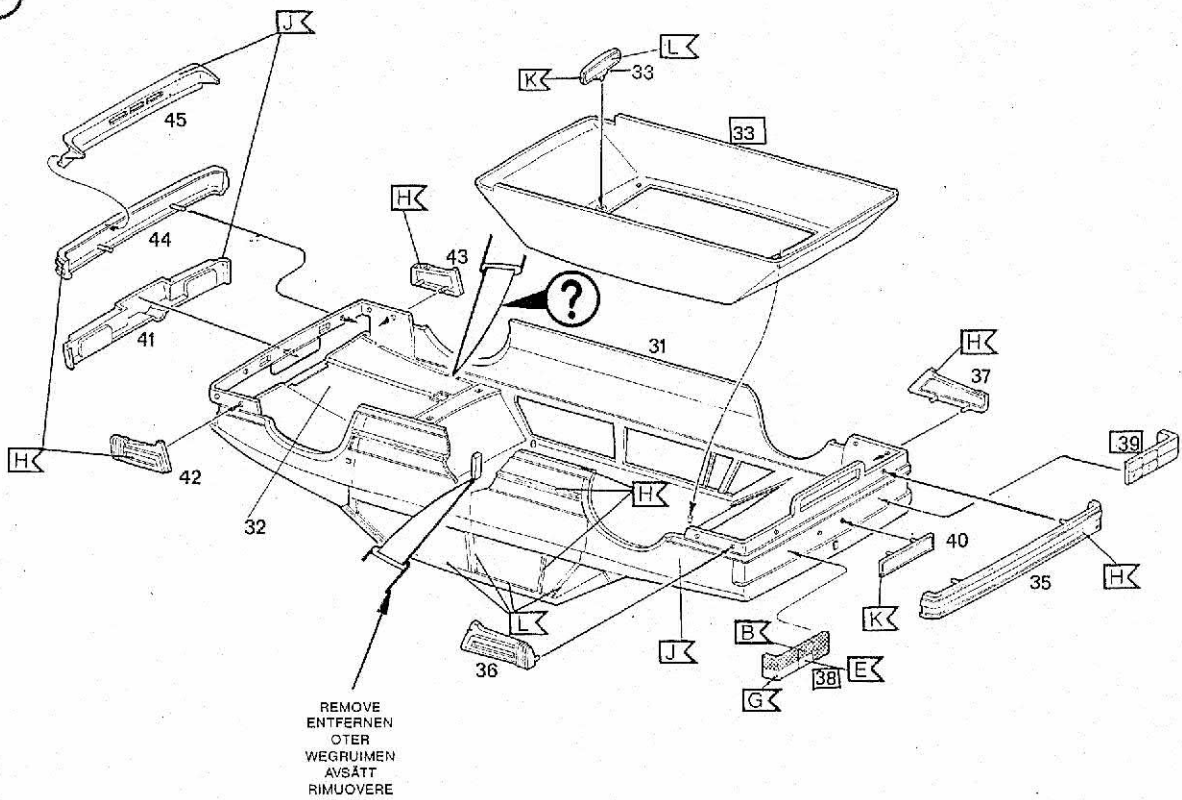

7

