

MIG-29A FULCRUM



With over 1,000 **MIG-29 Fulcrums** produced between 1977 and 1992, it must be recognized that the **MIG-29** is one of the three or four most important fighter aircraft in the air today. The **MIG-29** is frequently compared to the F-16 Fighting Falcon, while its companion interceptor/fighter the SU-27 shows greater similarity to the F-15 Eagle or F-18 Hornet

The **MIG-29** was designed in the early '70s to equal or surpass the performance of any known western block fighter. With its extreme agility, the **MIG-29** is Certainly an equal to the Falcon and probably its superior in many aspects such as twin-engine reliability and ease of maintenance. Five mechanics can remove and replace and test an engine in one hour or less! The **MIG-29** was designed for easy field maintenance with a minimum of skilled labor.

Powered by the RD-33 turbofan engines, a fully loaded **Fulcrum** can take off on one engine and subsequently air-start the second engine after lifting off. Armed with air-to-air AA-10, AA-11 or AA-8 missiles, the **Fulcrum** is more than equal in air-to-air combat. For the ground attack role, the **MIG-29** can carry the UB-32-57 rocket pods or the larger unguided S-8K rockets. Additionally, each **MIG** carries an internal 30mm cannon and 150 rounds of ammunition. The GSh-301 cannon is known for its very fine accuracy.

This model represents a late production version of the improved **MIG-29A**. Many significant improvements were incorporated into the design of the plane as it went through its production cycles. Each batch of aircraft was improved from earlier versions.

Flown by all former Soviet-bloc nations and many customer-client countries, the **MIG-29A** will be one of the most important fighters well into the 21st century.



Cement Parts
 Coller
 Kleben
 Pegar
 Incollare
 Colar
 Kleven



DO NOT cement
 Ne pas coller
 Nicht kleben
 No pegar
 Non incollare
 Nao colar
 Niet kleven



Cut away
 Couper
 Scheiden
 Cortar
 Tagliare
 Cortar
 Snijden



Optional parts
 Choix
 Auswahlmöglichkeit
 Eleccion
 Scelta
 Opcao
 Keuze



3

Repeat operation
 Répéter l'opération
 Vorgang wiederholen
 Repetir la operación
 Ripetere
 Repetir a operação
 Herhalen

1 ASSEMBLY OF COCKPIT AND FUSELAGE FRONT

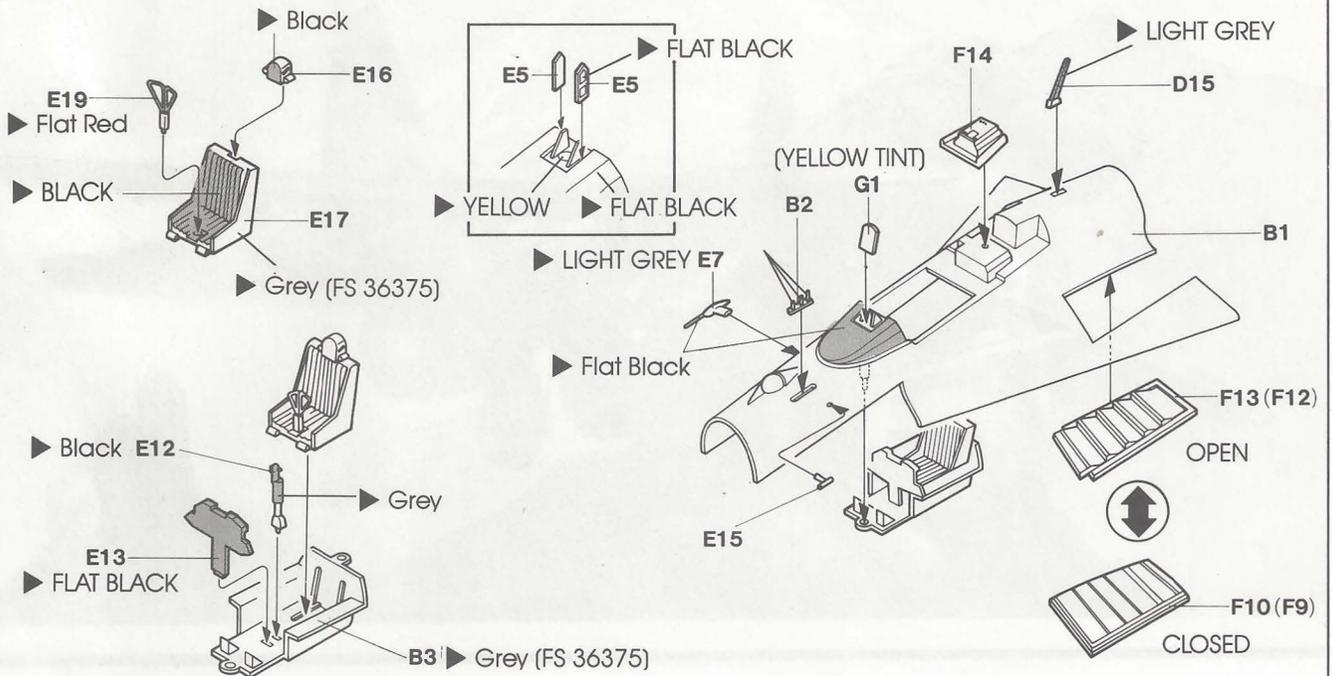

2 ASSEMBLY OF FUSELAGE

INTERIOR COLOR
 Grey (FS 36375)

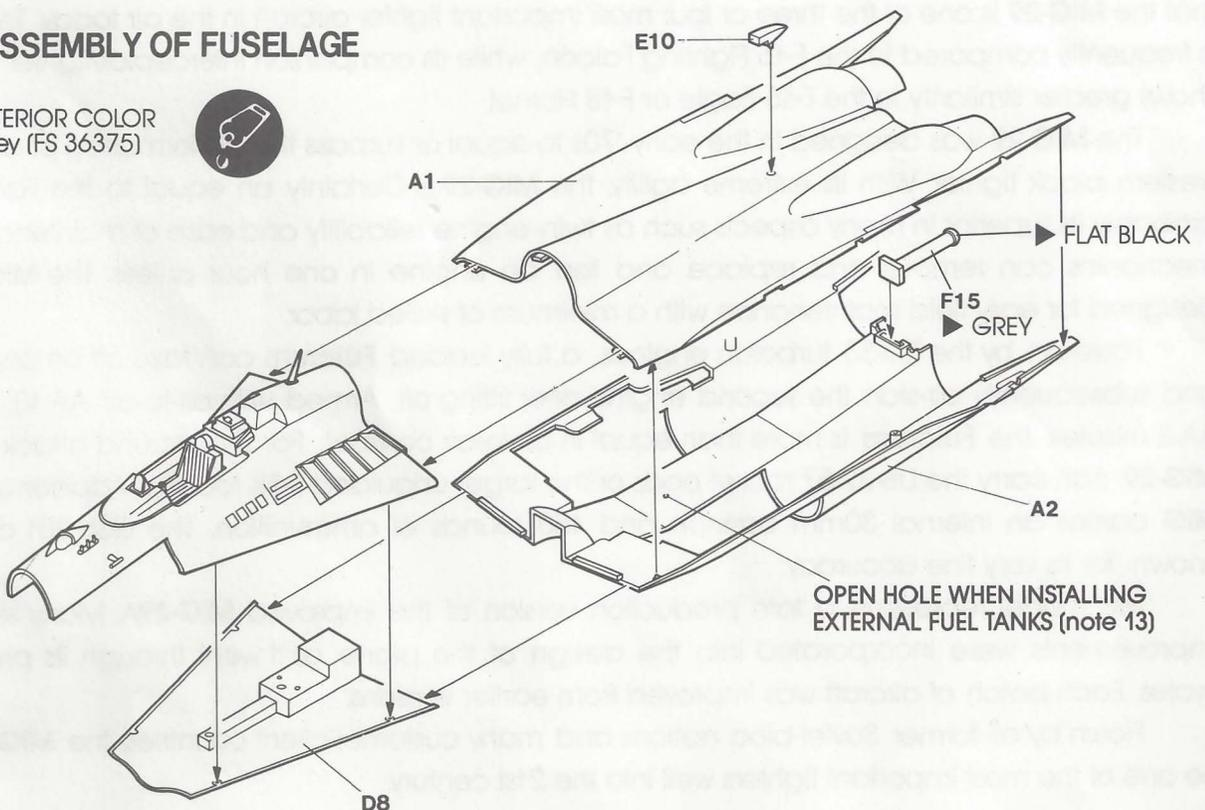

3 CANOPY INSTALLATION

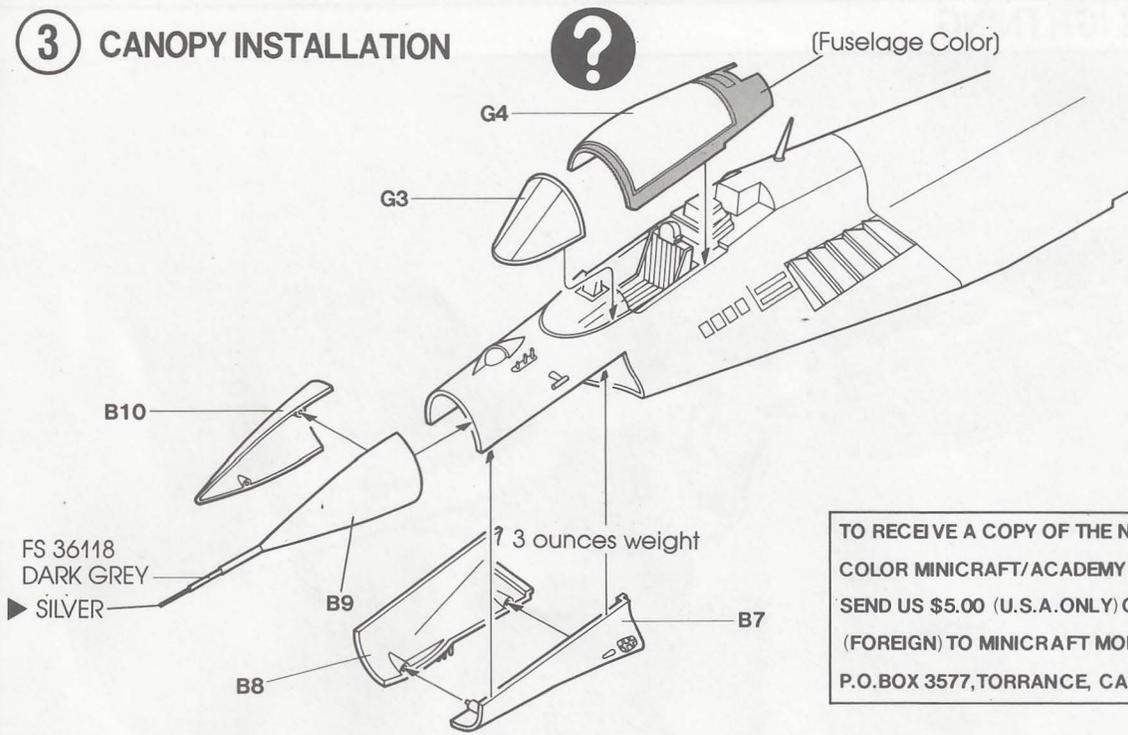

TO RECEIVE A COPY OF THE NEWEST FULL COLOR MINICRAFT/ACADEMY CATALOG, SEND US \$5.00 (U.S.A. ONLY) OR US \$6.00 (FOREIGN) TO MINICRAFT MODELS, INC. P.O. BOX 3577, TORRANCE, CALIF 90510

4 ASSEMBLY OF LANDING GEAR BAY

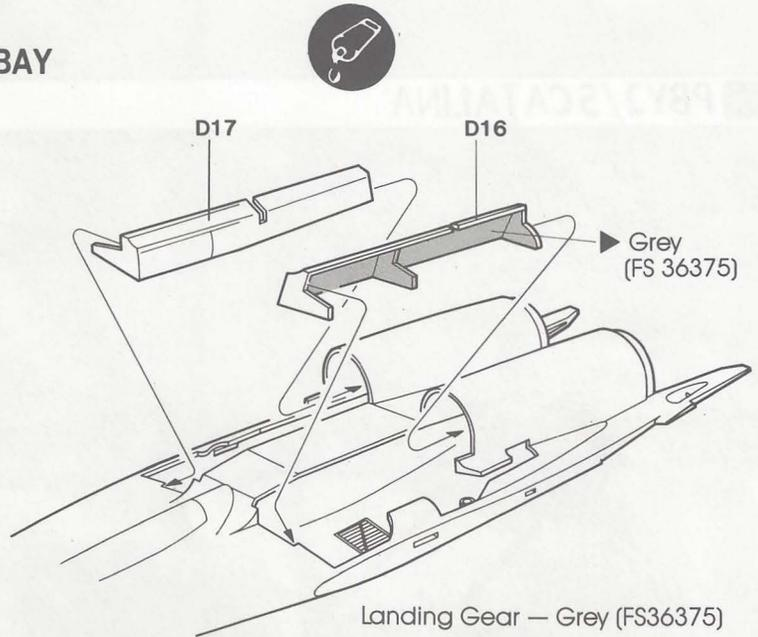

Landing Gear — Grey (FS36375)
Wheel Hubs-Dark Green (FS 34226)

5 ASSEMBLY OF LANDING GEAR I

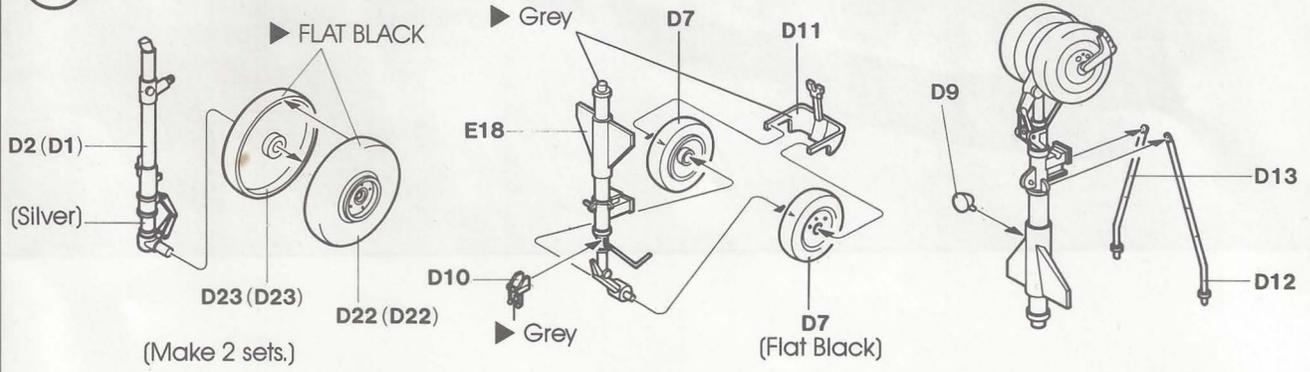

6 ASSEMBLY OF LANDING GEAR II

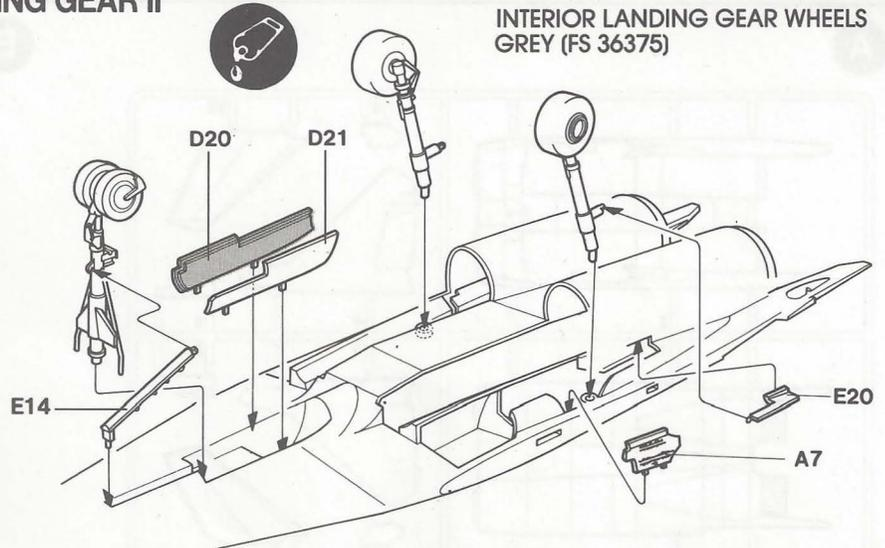
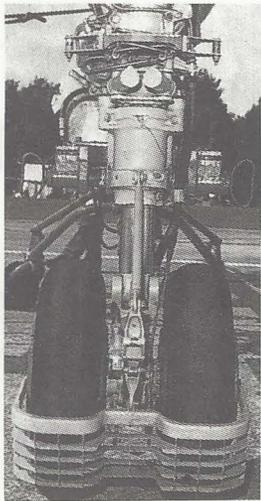

7 ASSEMBLY OF AIR INTAKE

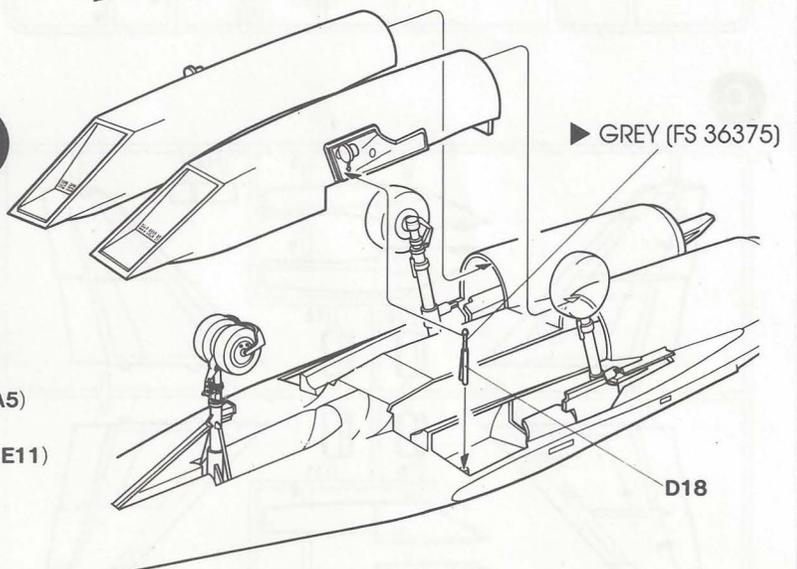
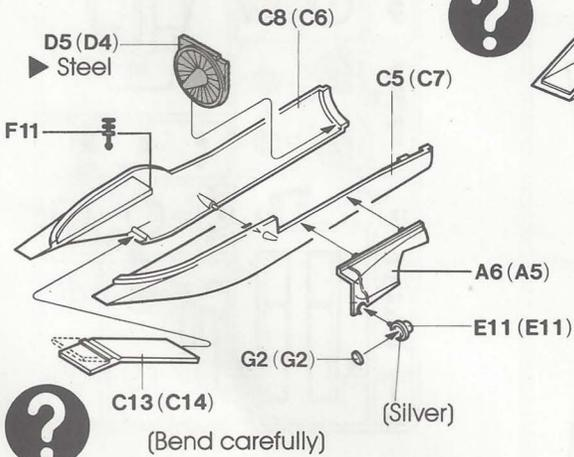

8 ASSEMBLY OF AIR BREAK

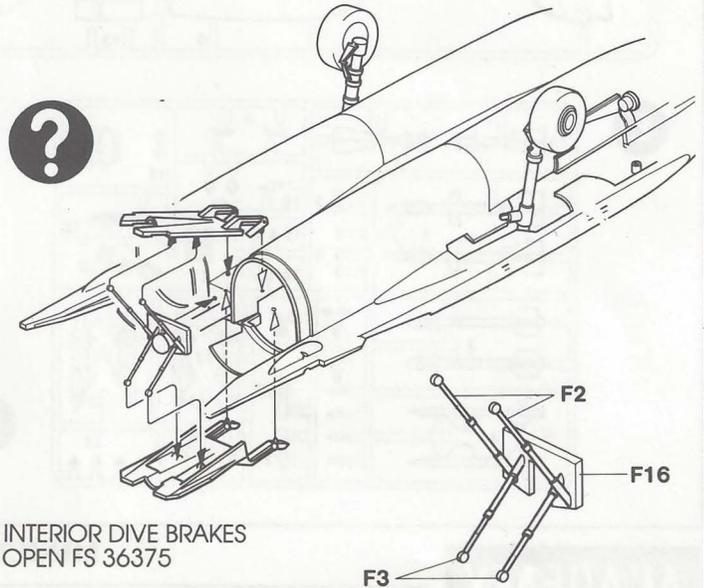
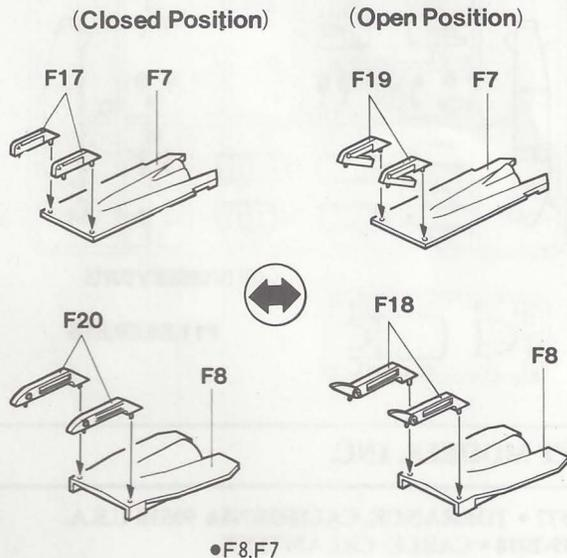

DO NOT ASSEMBLE WHEN IN CLOSED POSITION

9 ASSEMBLY OF EXHAUST CONE

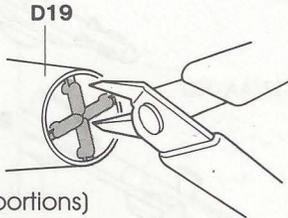
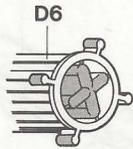

(Remove the useless portions)

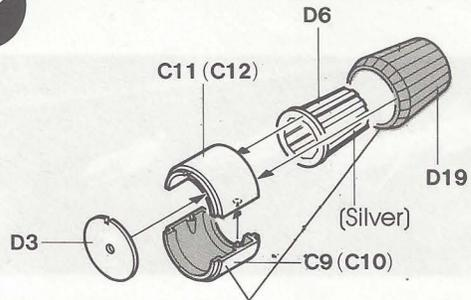

(Make 2 sets)

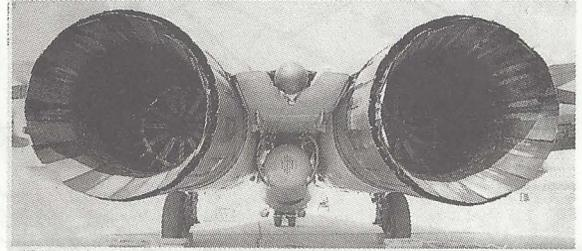
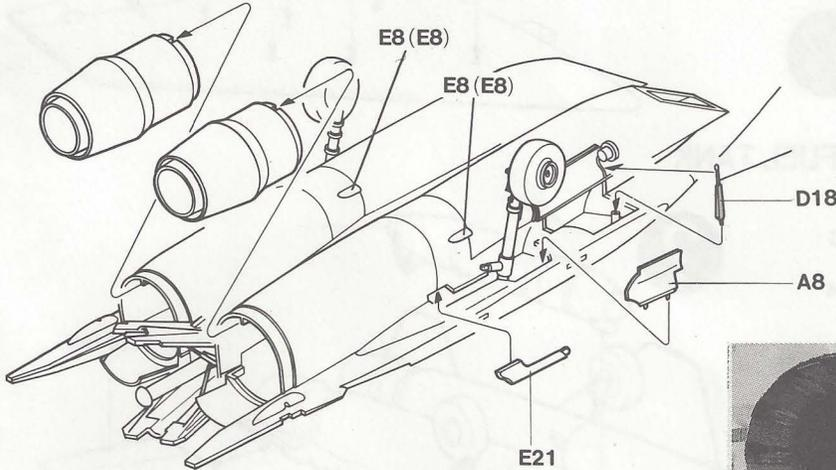

10 ASSEMBLY OF WING

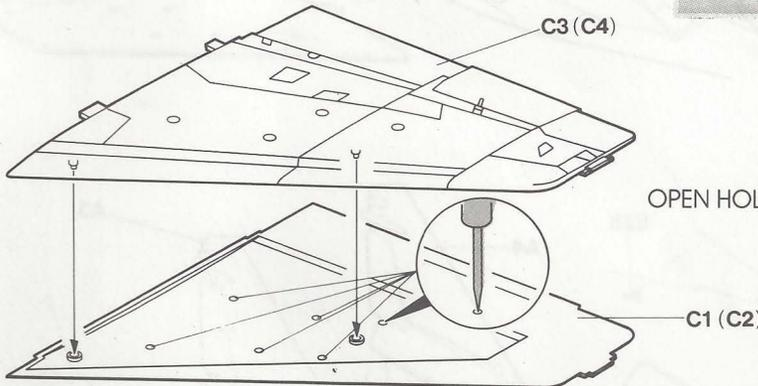

OPEN HOLES IF INSTALLING PYLONS



■ R-60MK/AA-8

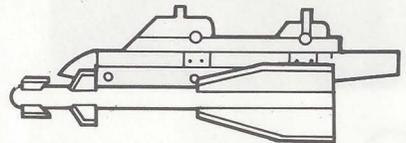

11 ASSEMBLY OF MISSILES I



■ R-27/AA-10D

■ R-73/AA-11

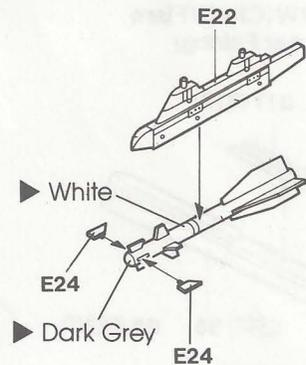
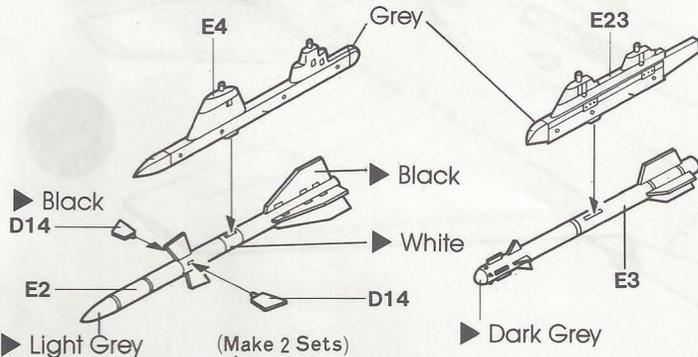

12 ASSEMBLY OF MISSILES II

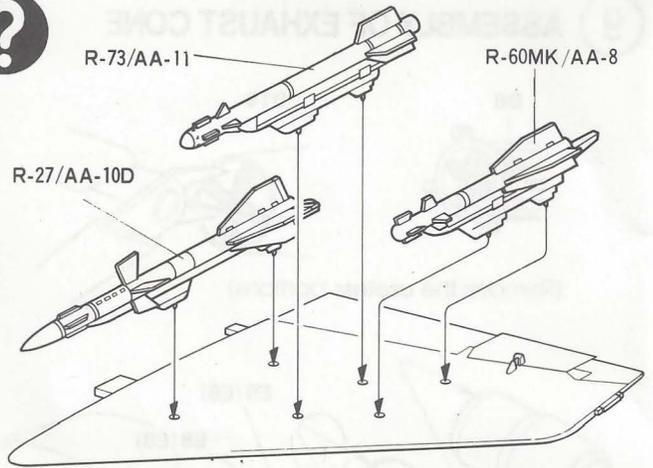
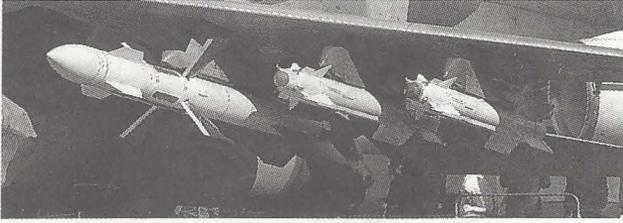

13 ASSEMBLY OF EXTERNAL FUEL TANK

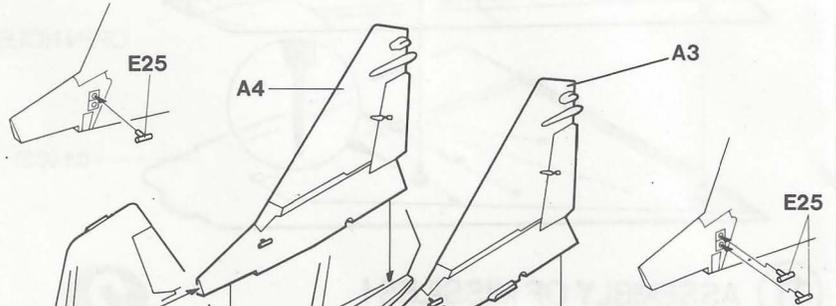
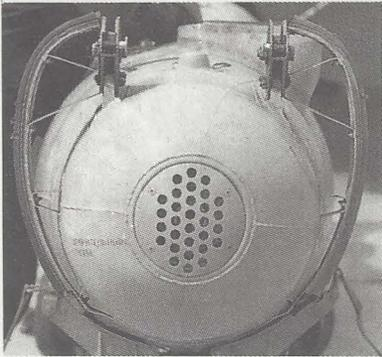
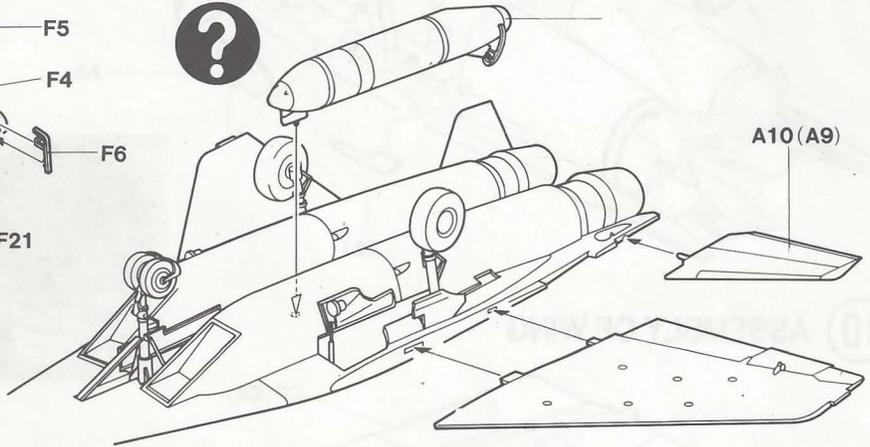
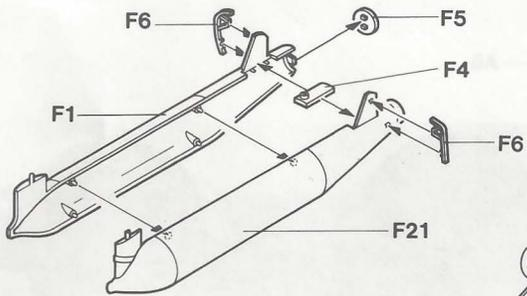

14 ASSEMBLY OF RUDDER

■ ASO-2W (Chaff/Flare Dispenser Fairing)

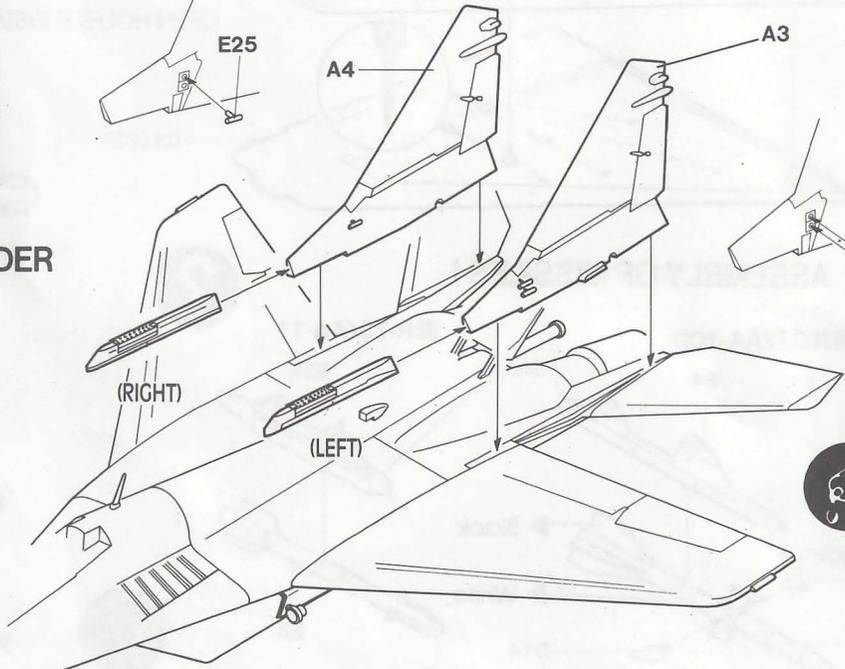
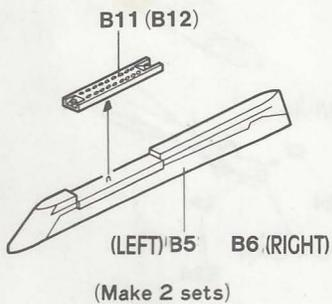

PARTS LOCATOR

A

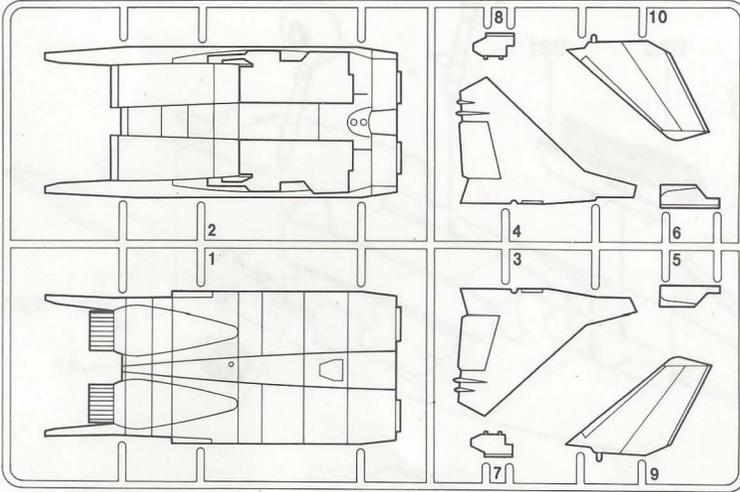

B

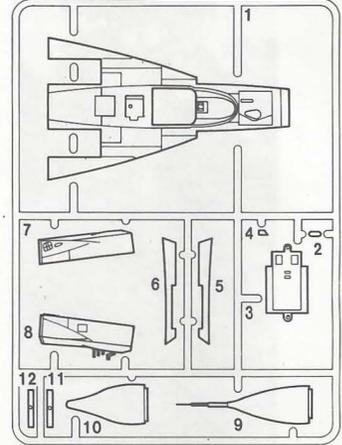

C

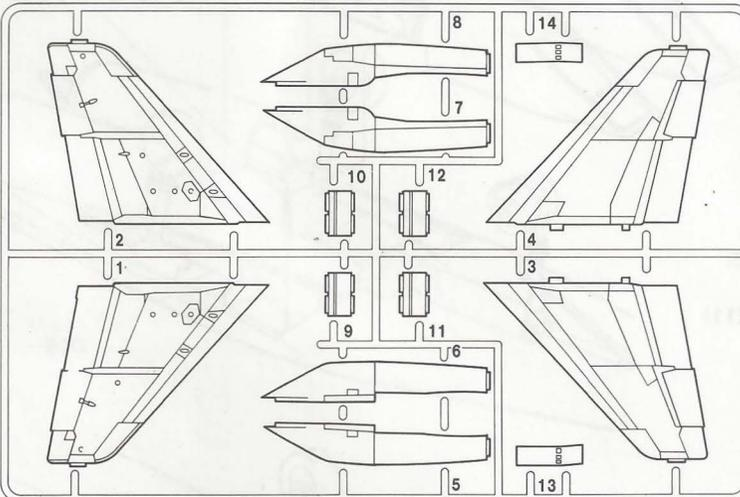

D

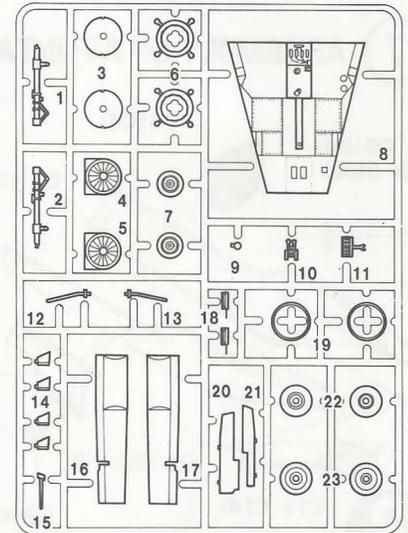

E

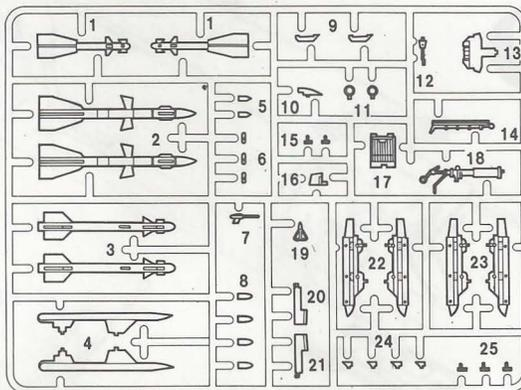

F

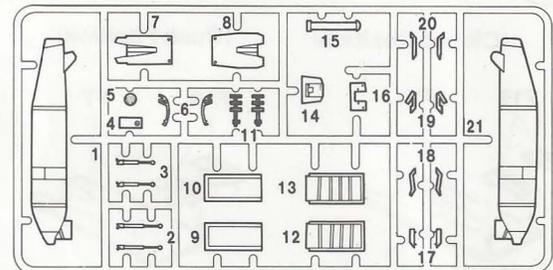

un necessary parts

G

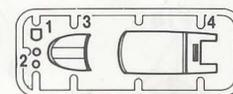

F11,E6,E9,E15

**ACADEMY
MINICRAFT**

MINICRAFT MODELS, INC.

1510 WEST 228 TH ST. • P.O. BOX 3577 • TORRANCE, CALIFORNIA 90510 U.S.A.
TEL: (213) 775-8836/7 • FAX: (310) 539-2018 • CABLE: CALAMTINT

■ P38J/L LIGHTNING

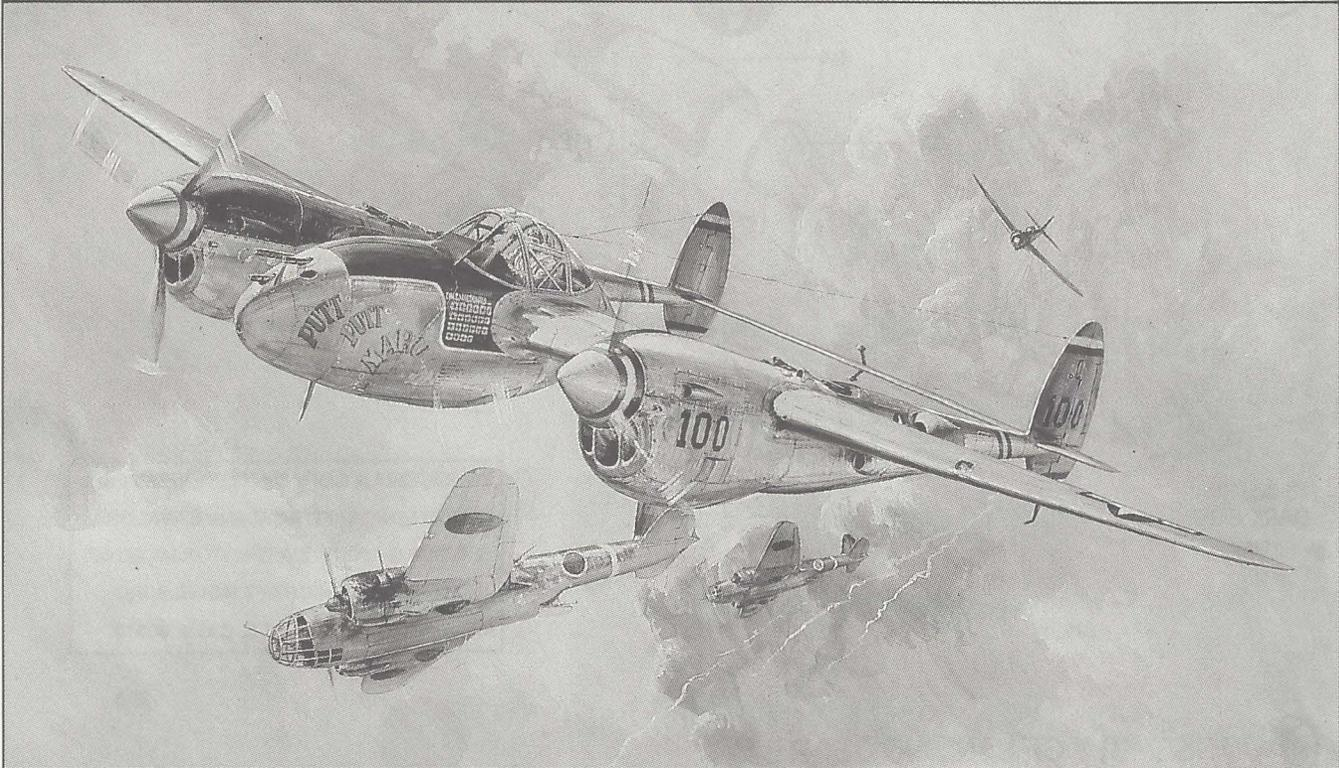

■ PBY2/5 CATALINA

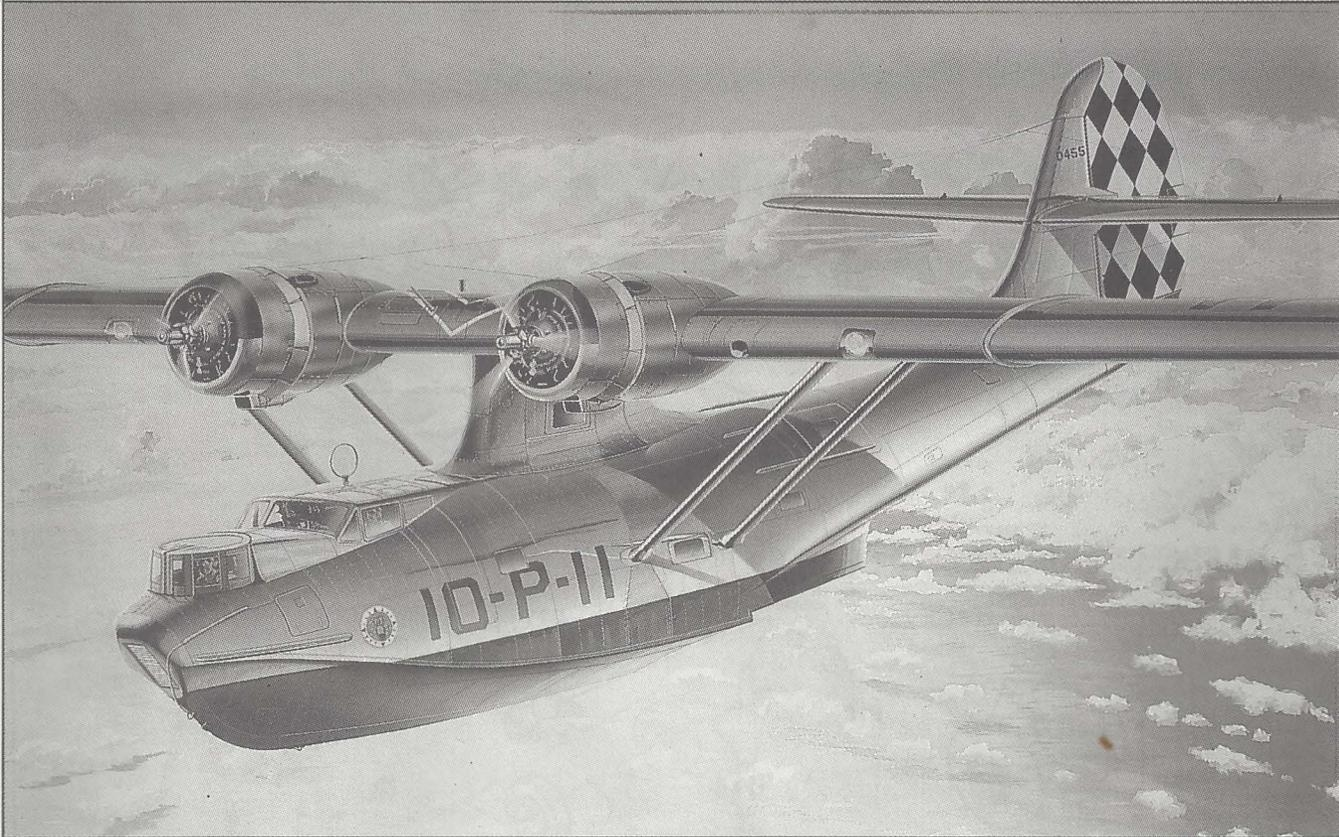

MIG 29A Fulcrum Decal and Painting Instructions

Russaon Version

	GUNSHIP GRAY	FS 36118
	BLUE GRAY	FS 35327
	LIGHT GRAY	FS 36375
	BLACK	

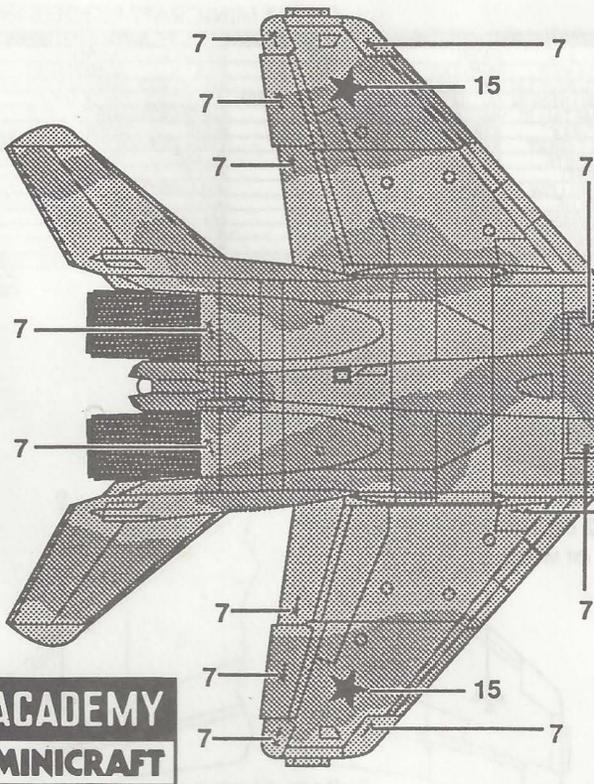
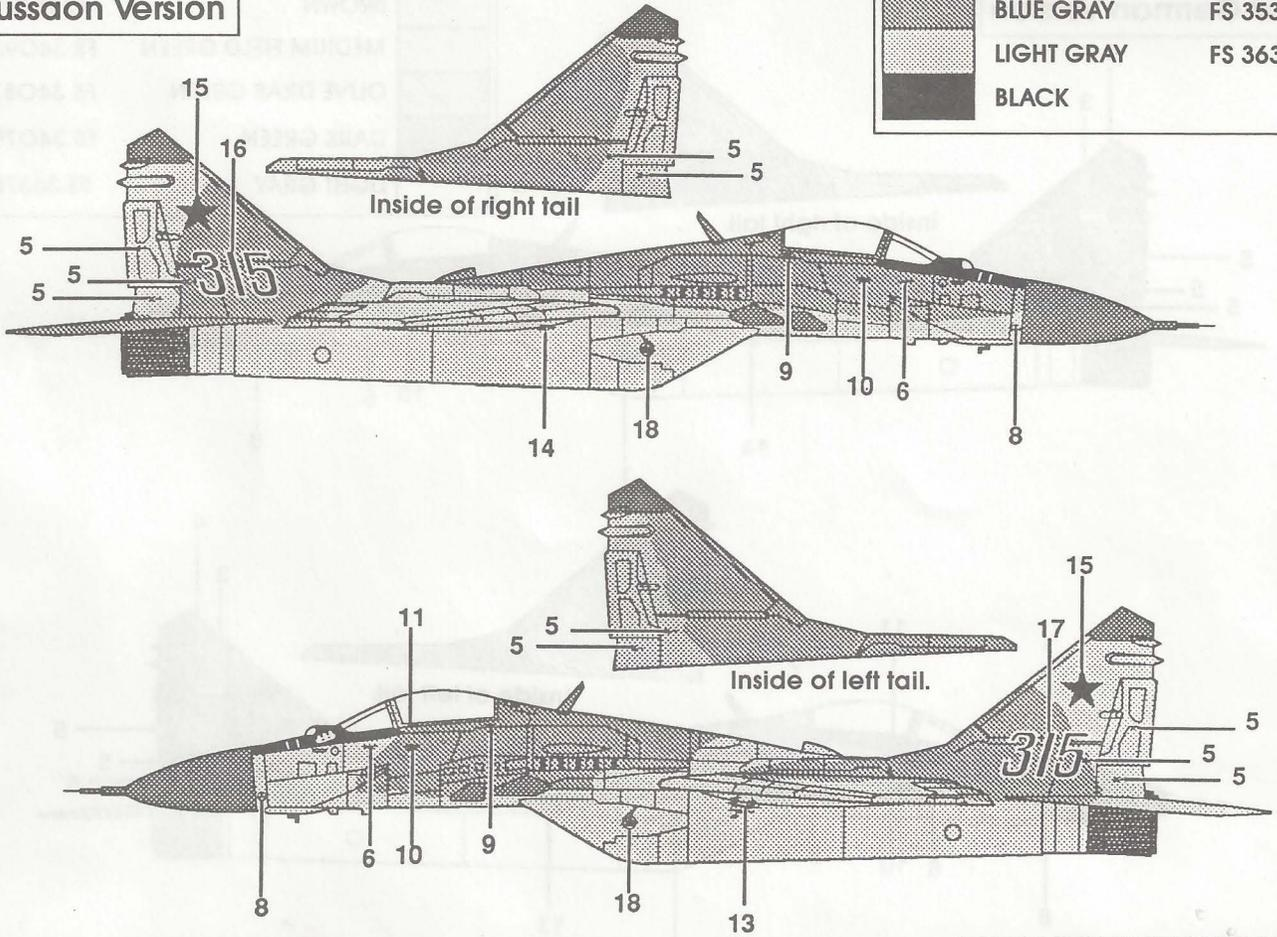

© 1993 MINICRAFT MODELS INC.

ENGLISH	FRENCH	GERMAN	SPANISH	ITALIAN
BLACK	NOIR	SCHWARZ	NEGRO	NERO
SILVER	ARGENT	SILBERN	PLATA	ARGENTO
GLIMMETAL	METALLIC	METALLIC	METALICO	METALLICO
ALUMINUM	ALUMINIUM	ALUMINIUMFARBEN	ALUMINIO	ALLUMINIO
METALLIC	METALLIC	METALLIK	METALICO	METALLICO
GRAY	GRIS	GRAU	GRIS	GRIGIO
LT GRAY	GRIS CLAIR	HELLGRAU	GRIS CLARO	GRIGIO CHIARO
WHITE	BLANCO	WEISS	BLANC	BIANCO
RED	ROUGE	ROT	ROJO	ROSSO
YELLOW	JAUNE	GELB	AMARILLO	GIALLO
BLUE	BLEU	BLAU	AZUL	BLU
ORANGE	ORANGE	ORANGE	NARANJADO	ARANCIO
GREEN	VERT	GRUN	VERDE	VERDE
BROWN	BRUN	BRAUN	MARRON	MARRONE
TAN	BRUN CLAIR	GELBBRAUN	CANELA	MARRONE CHIARO

12 on Underside of wing

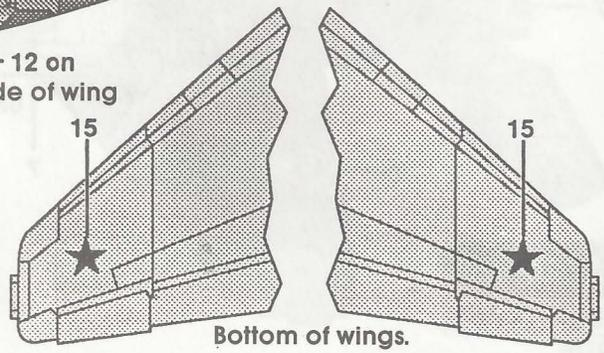

Bottom of wings.

MIG 29A Fulcrum Decal and Painting Instructions

West German Version

	GUNSHIP GRAY	FS 36118
	BROWN	FS30219
	MEDIUM FIELD GREEN	FS 34095
	OLIVE DRAB GREEN	FS 34087
	DARK GREEN	FS 34079
	LIGHT GRAY	FS 36375

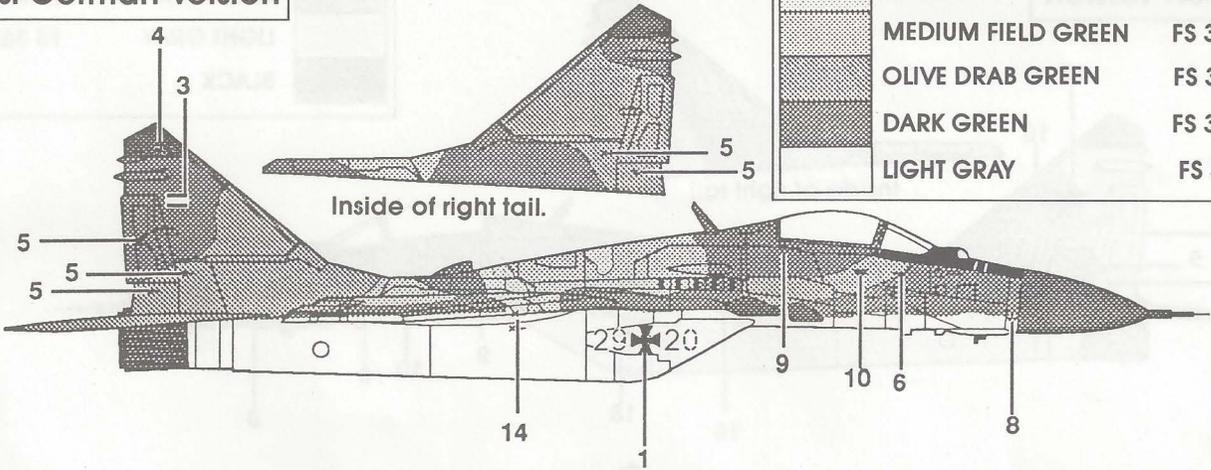

Inside of right tail.

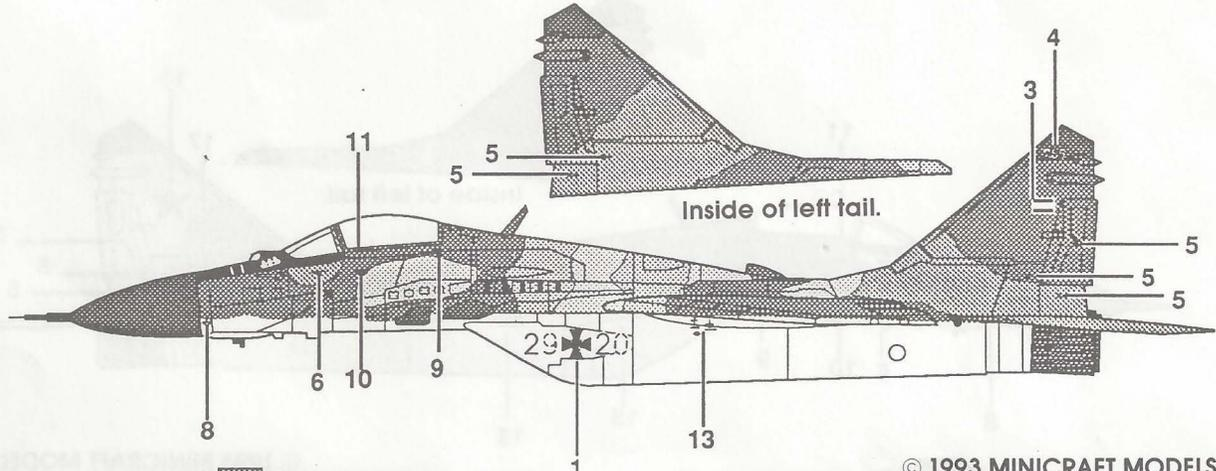

Inside of left tail.

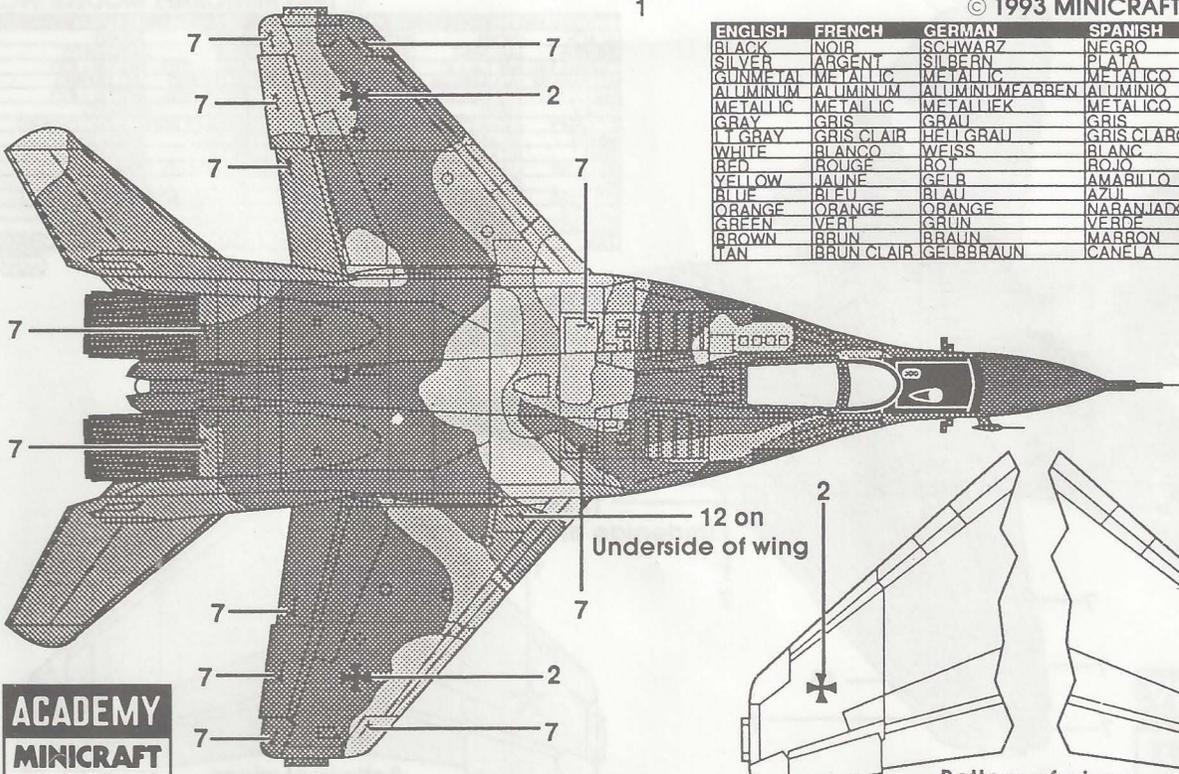

© 1993 MINICRAFT MODELS INC.

ENGLISH	FRENCH	GERMAN	SPANISH	ITALIAN
BLACK	NOIR	SCHWARZ	NEGRO	NERO
SILVER	ARGENT	SILBERN	PLATA	ARGENTO
GUNMETAL	METALLIC	METALLIC	METALICO	METALLICO
ALUMINUM	ALUMINIUM	ALUMINIUMFARBEN	ALUMINIO	ALLUMINIO
METALLIC	METALLIC	METALLIEK	METALICO	METALLICO
GRAY	GRIS	GRAU	GRIS	GRIGIO
L.T. GRAY	GRIS CLAIR	HELT GRAU	GRIS CLARO	GRIGIO CHIARO
WHITE	BLANCO	WEISS	BIANCO	BIANCO
RED	ROUGE	ROT	ROJO	ROSSO
YELLOW	JAUNE	GELB	AMARILLO	GIALLO
BLUE	BLEU	BLAU	AZUL	BLU
ORANGE	ORANGE	ORANGE	NARANJADO	ARANCIO
GREEN	VERT	GRUN	MARRON	VERDE
BROWN	BRUN	BRAUN	MARRON	MARRONE
TAN	BRUN CLAIR	GELBBRAUN	CANELA	MARRONE CHIARO

Designed by WAD

12 on Underside of wing

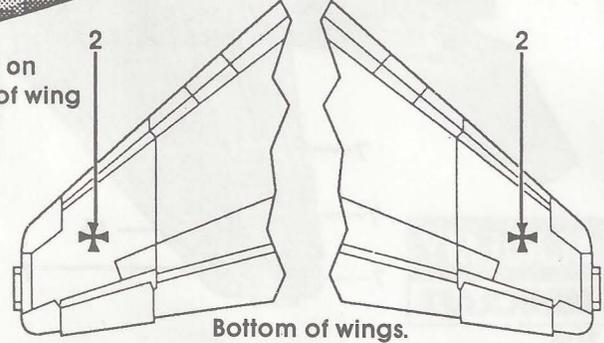

Bottom of wings.

ACADEMY MINICRAFT

MiG 29A FULCRUM #2116

1 29 ✝ 20

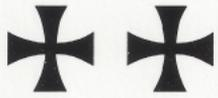

ACADEMY
MINICRAFT

29 ✝ 20

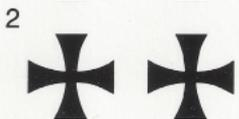

7 X— X—

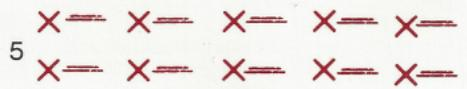

4

X— X—

X— X—



X— X—

X— X—



17

315

12
✓



13
✝ ⊥



16

315

14
X— E—