

Meteor F.8 General Stencils

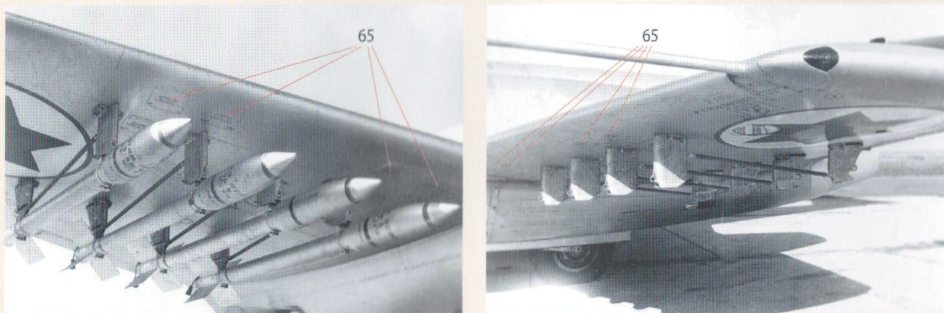

# Middle East Meteors

For Xtrakit, PJ Productions, MPM,  
Matchbox and Czechmaster kits

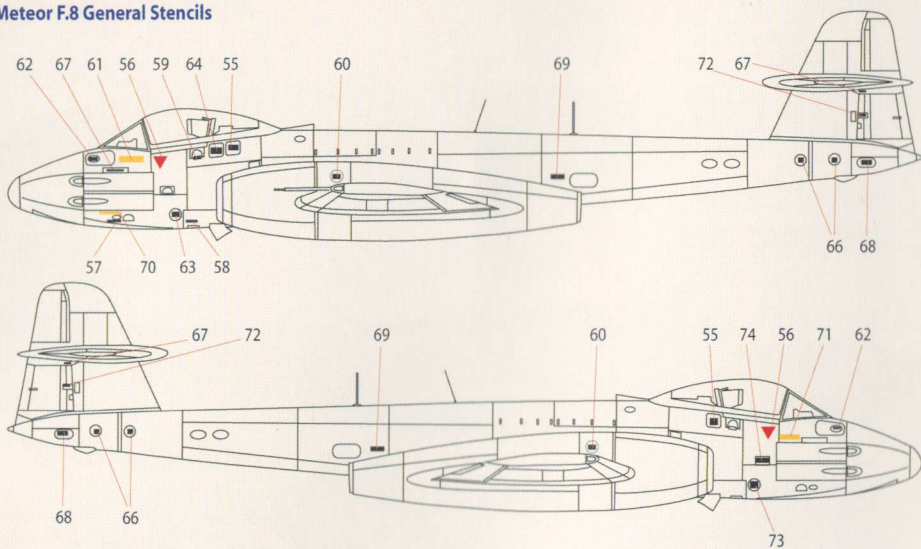

Egypt



Israel



Syria



# IsraDecal

THE COMPLETE SCALE MODELLING EXPERIENCE





## Israeli Air Force

The first 4 IAF's Meteors were T.7 type. They got the names "Sufa", "Sa'ar" (two names for storm or gale), Ra'am (Thunder) and Barak (Lightning). The small Hebrew "A" along the number is short for training in Hebrew. The planes were in natural metal finish. The decals appears on both sides.

### Meteor T.7 #A13, 1953

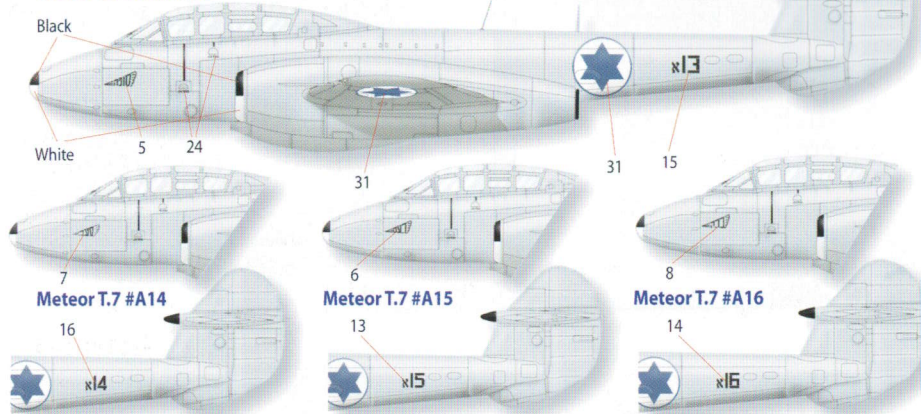

### Meteor FR.9 #36, 1956

This is the only Israeli Meteor that shot down enemy planes. On September 1st, 1955, two Egyptian Vampires were shot down by this FR.9 Meteor. The 2 marks shown on its nose.

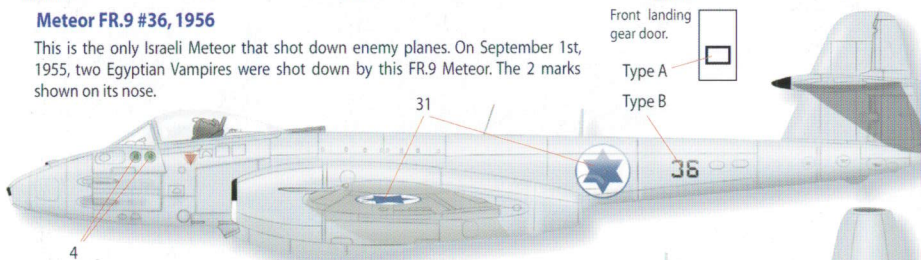

### Meteor F.8 #04, 1956 "Sinai Campaign"

During the 1956 war the Meteors were in natural metal finish. A black band was painted on the fuselage, between the IAF insignia and the plane's number. Other black stripes were painted on the upper and lower sides of the wing. These stripes were for identification during the war.

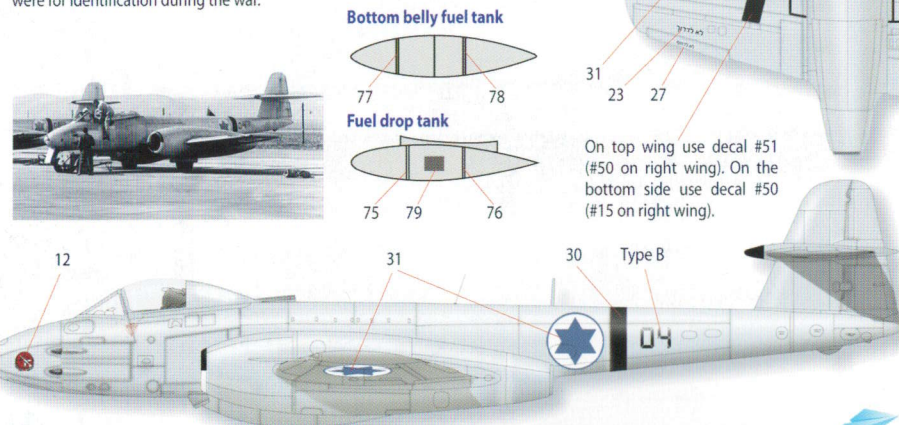

### Meteor T.7 #18, 1957

After the 1956 war the squadron badges on all IAF's aircraft moved from the nose section to the tail. The "A" code letter was removed and only the numbers were remained.

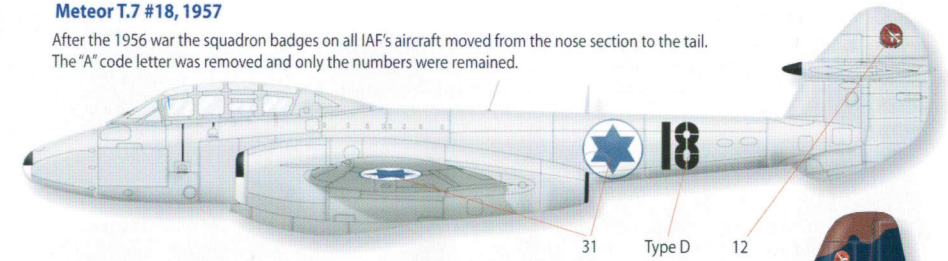

### Meteor F.8 #02, 1960

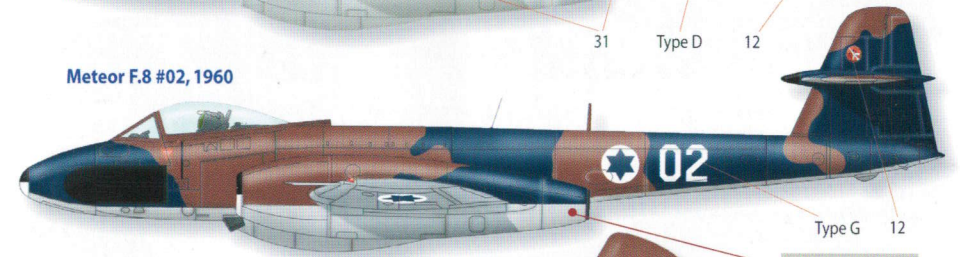

Like the rest of the IAF planes, the Meteors were painted in the Blue/Brown/Gray color scheme. The paints were glossy and a sharp edge created the pattern between the colors. The cannons section were painted in black and the squadron badge moved to the tail.

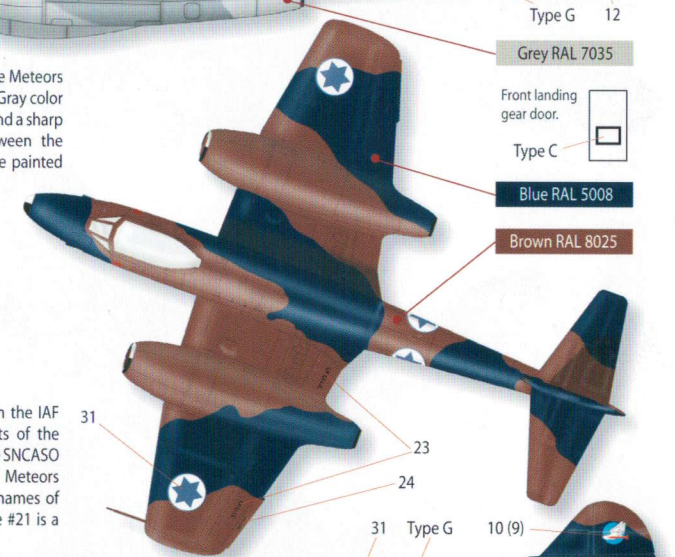

### Meteor T.7 #15, 1969

The last 3 Meteors that served in the IAF were in service with the Knights of the North squadron that operated the SNCASO Vautours. Like the Vautours, the Meteors got names as well. They all got names of snakes. #15 and #17 are T.7 while #21 is a T.7.5 (It has a tail section of a F.8).

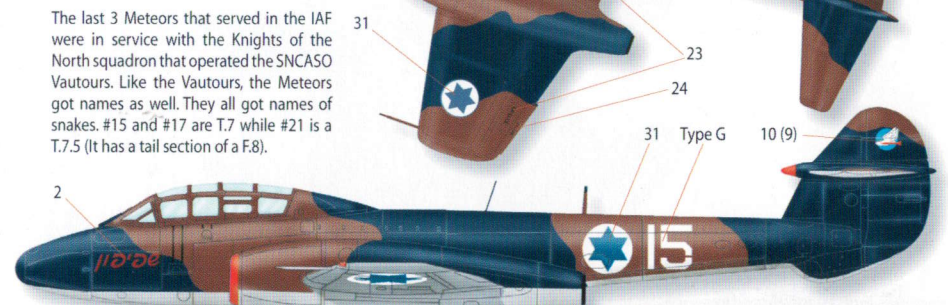

### Meteor T.7 #17, 1969

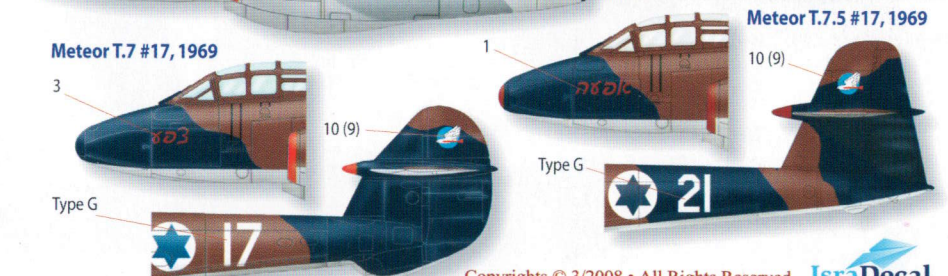

### Meteor T.7.5 #17, 1969



### Meteor F.8 #09, 1963

When the First Jet squadron received their Mirage IIIC they transferred their Meteors to the Knight of the Orange Tail squadron which operated the planes from 1962 till 1964. The planes used for towing air to air targets for other aircraft.

#20 on top of left wing and bottom right wing

#19 on top of right wing and bottom left wing

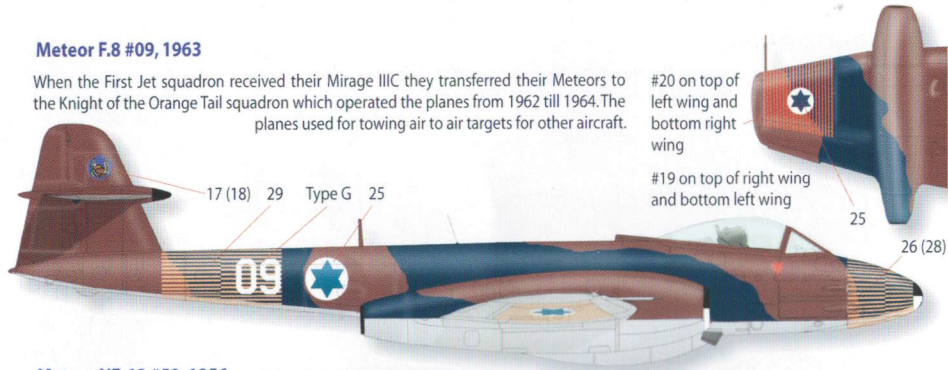

### Meteor NF-13 #52, 1956

5 Meteors NF.13 were in service with the Bat squadron (another one has crashed during the ferry flight to Israel). They were painted in England in similar colors to those in the IAF service. On top, the planes were painted in Oxford Blue and Dark Earth and on the bottom with Extra Dark Sea Grey. The planes were in matt finish.

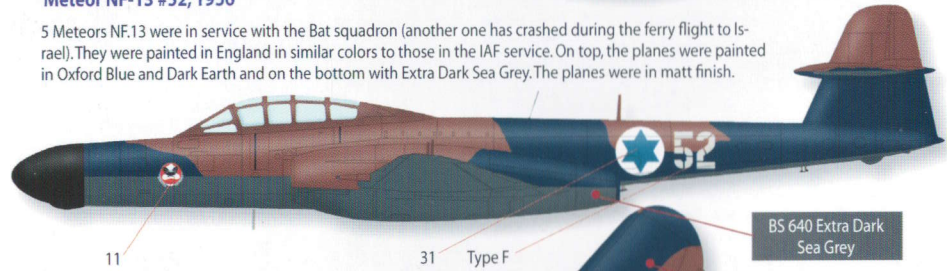

BS 640 Extra Dark Sea Grey

BS 105 Oxford Blue

BS 450 Dark Earth



Decal #31 on top left wing and bottom right wing.

## Egyptian Air Force

The Egyptian Air Force operated 4 types of Meteors between the years 1949 - 1958. They operated 12 Mr. 4, 6 T.7, 12 F.8 and 6 NF-13 Meteors. The Mk.4, T.7 and F.8 where in natural metal finish while the NF-13 where in ex-RAF color scheme which included the BS 641 Dark Green on top of BS 637 Medium Sea Grey.

### Meteor Mk.4 #1407, 1950



### Meteor T.7 #1400, 1955

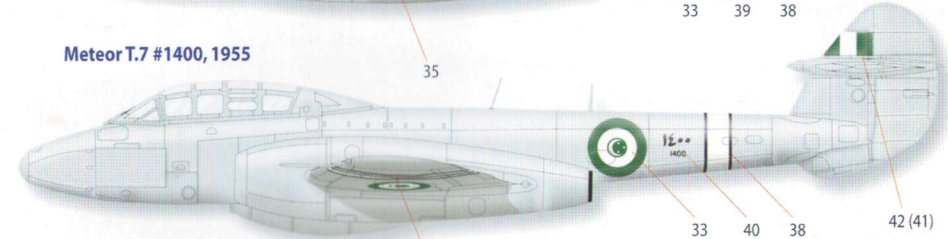

### Bottom belly fuel tank



### Left drop tank

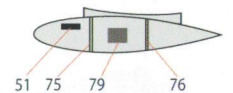

### Right drop tank

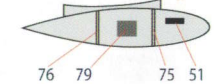

The set provided numbers to do any other Meteors as you wish (Type I).

### Meteor F.8 #1425, 1955

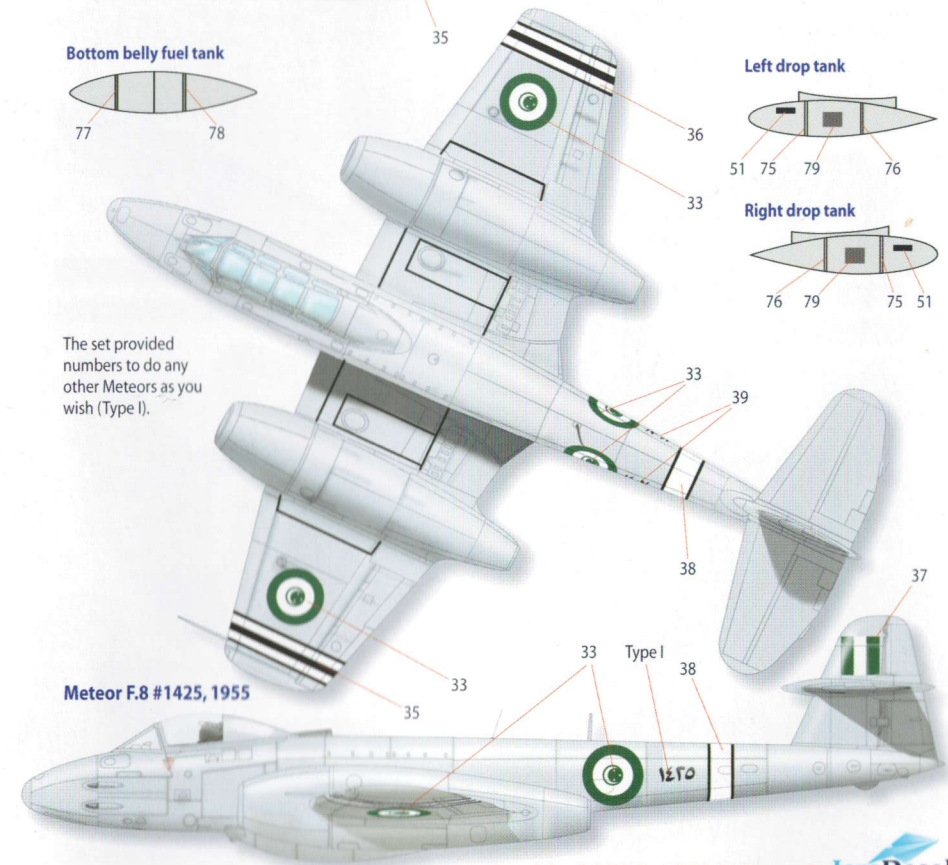



Meteor NF-13 #1432, 1955

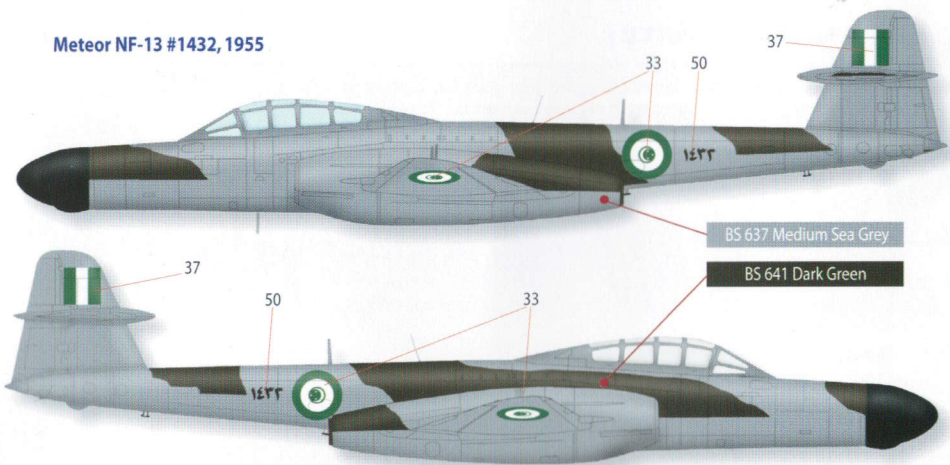

### Syrian Air Force

The Syrian Air Force operated the Gloster Meteors from 1951 till the end of the decade. Like the Israeli AF the Syrians operated the F8, FR.9, T.7 and the NF-13 versions. The Syrian planes when painted in RAF pattern but in different colors.

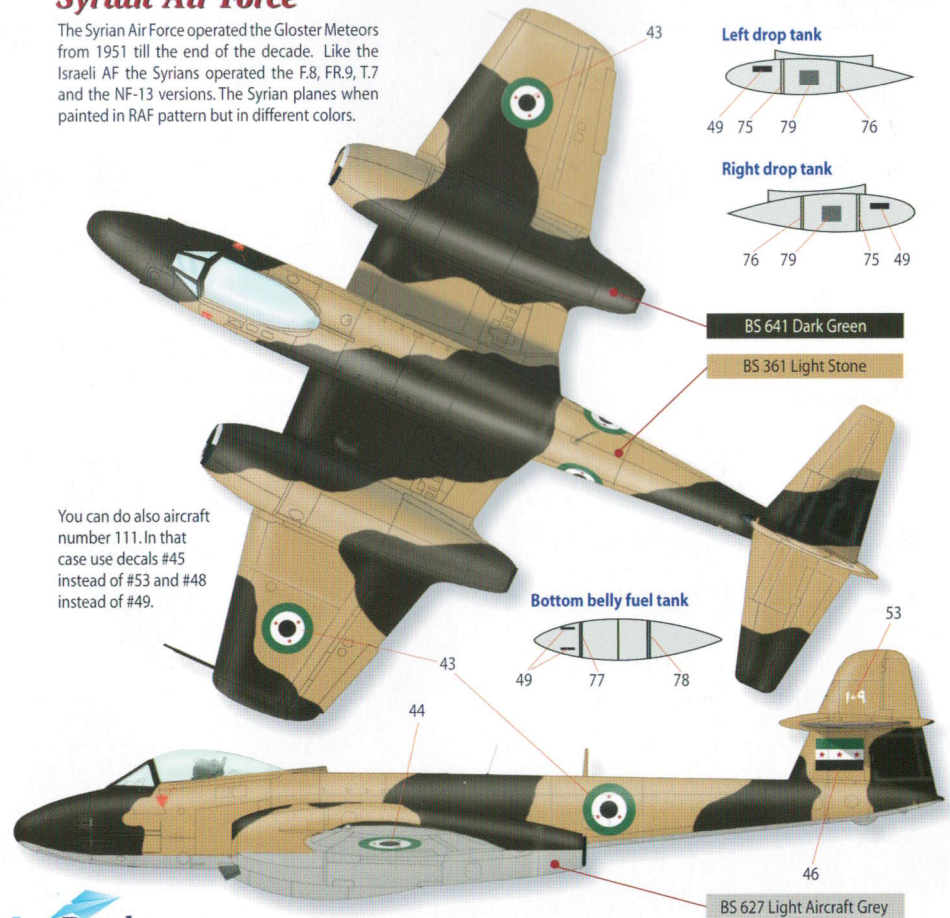

You can do also aircraft number 111. In that case use decals #45 instead of #53 and #48 instead of #49.

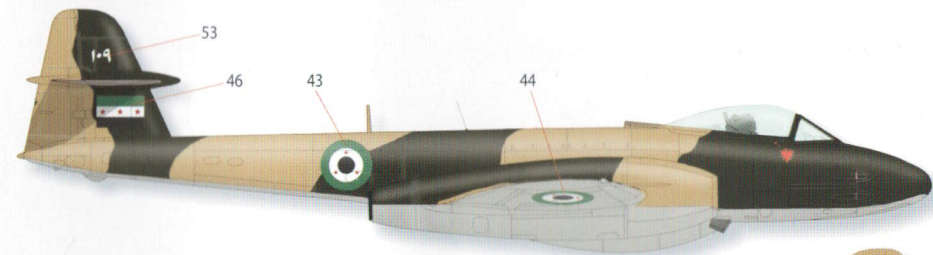

Meteor NF-13 #476, 1957

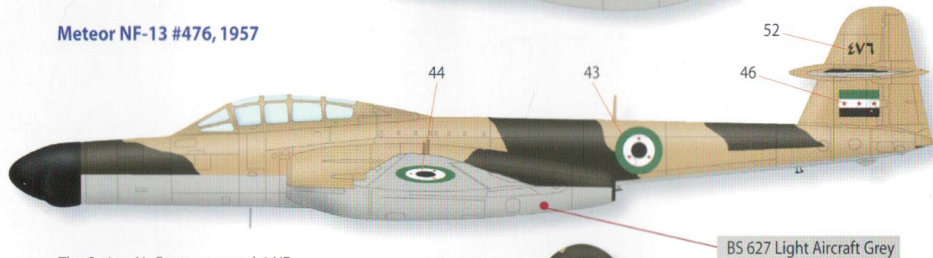

The Syrian Air Force operated 6 NF-13 Meteors from 1956 till the end of the decade.

The set provides numbers to do any other Meteors as well (Type I).

