



# 1:48 Specialist Spitfires

A82015 SCALE MODEL CONSTRUCTION KIT | Wingspan: 232mm Fuselage Length: 195mm | Two Decal Schemes Included | Two Build Options

Although best known for its use as a daylight interceptor fighter, and in later days as a fighter bomber, the Spitfire also undertook a number of specialist roles for the RAF. During the winter of 1941/42 it was feared that the Luftwaffe would once again strike at the heart of Britain by bombing its major cities as it had the winter before. While single engine fighters, like the Hurricane, had been used in the past to intercept these bombers it was decided that a more potent fighter was needed and a number of Spitfire Vbs were converted to night fighters by painting them black. The idea was to direct them to the bombers using searchlights. However the operations were not a success. The Spitfire could be tricky to fly at night, with its narrow track undercarriage and immense engine torque making even taking off difficult. Many were lost in accidents and the idea was quietly dropped. Another use for the Vb towards the end of the war was as a high speed air sea rescue machine. Operating over the sea off the Suffolk coast, these Spitfires were able to spot downed aircrew and radio their position to enable Coastal Command or the Royal Navy to rescue them.

Airfix would like to thank the Historic Aircraft Collection (<http://www.historicaircraftcollection.ltd.uk/>) and Edgar Brooks for their assistance with creating this model.

### Specification:

Speed: 370mph (595Km/h)

Range: 470m (760km)

Wingspan: 36 ft. 10 in (11.23 m)

Length: 29 ft. 11 in (9.12 m)

Armament: 2 x 20mm cannon & 4 x .303in Machine Guns

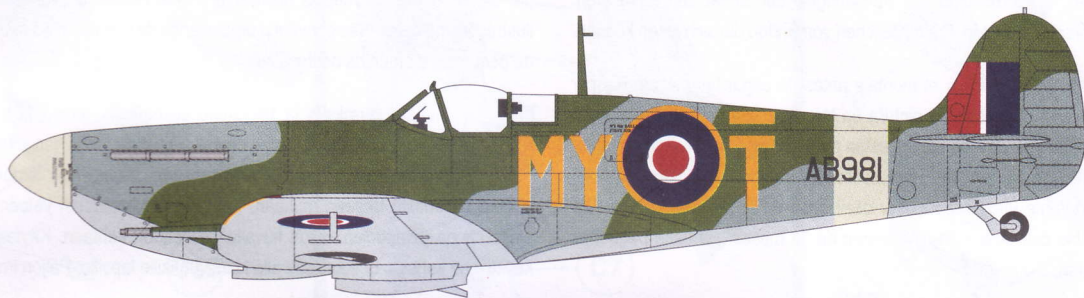

**A** Supermarine Spitfire LF.Mk.Vb

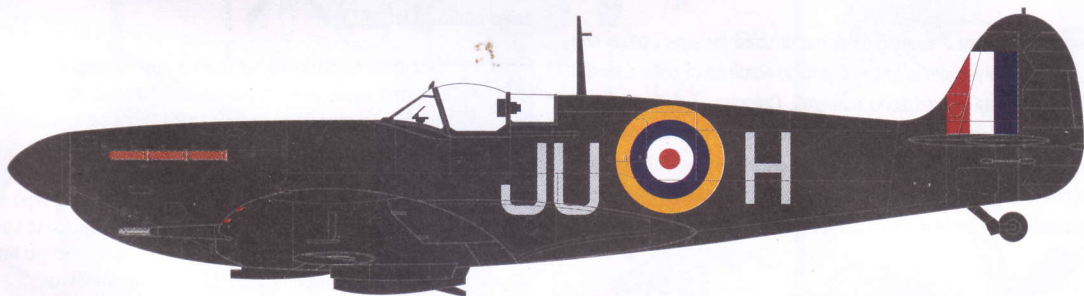

**B** Supermarine Spitfire Mk.Vb

## Club Special Limited Edition

### FOR BEST RESULTS:

Surfaces to be painted should be clean – before parts are removed from the sprue, wash in warm, soapy water, rinse and dry thoroughly. Stir paints thoroughly before use.

### PLEASE NOTE:

Some parts in the kit may not be required to build the model specified.

**HORNBY  
HOBBIES**



# ASSEMBLY INSTRUCTIONS

**GB** Study drawings and practice assembly before cementing parts together. Carefully scrape plating and paint from cementing surfaces. All parts are numbered. Paint small parts before assembly. To apply decals cut sheet as required, dip in warm water for a few seconds, slide off backing into position shown. Use in conjunction with box artwork. Not appropriate for children under 36 months of age, due to the presence of small detachable parts.

**FR** Étudier attentivement les dessins et simuler l'assemblage avant de coller les pièces. Gratter soigneusement tout revêtement ou peinture sur les surfaces à coller avant collage. Toutes les pièces sont numérotées. Peindre les petites pièces avant l'assemblage. Pour coller les décalques, découper le motif, le plonger quelques secondes dans de l'eau chaude puis le poser à l'endroit indiqué en décollant le support papier. Utiliser en même temps les illustrations sur la boîte. Ne convient pas à un enfant de moins de 36 mois – présence de petits éléments détachables.

**DE** Vor Verwendung des Klebers Zeichnungen studieren und Zusammenbau üben. Farbe und Plattierung vorsichtig von den Klebeflächen abkratzen. Alle Teile sind numeriert. Vor Zusammenbau kleine Teile anmalen. Um die Abziehbilder aufzukleben, diese ausschneiden, kurz in warmes Wasser tauchen, dann abziehen und wie abgebildet aufkleben. In Verbindung mit Abbildungen auf Schachtel verwenden. Ungeeignet für Kinder unter 36 Monaten. Kleine Teilchen vorhanden die sich lösen können.

**ES** Estudiar los dibujos y practicar el montaje antes de pegar las piezas. Raspar cuidadosamente el plateado y la pintura en las superficies de contacto antes de pegar las piezas. Todas las piezas están numeradas. Es conveniente pintar las piezas pequeñas antes de su montaje. Para aplicar las calcomanías, cortar la hoja, sumergir en agua tibia durante unos segundos y deslizarlas en la posición debida. Ver ilustraciones en la caja. No conviene a un niño menor de 36 meses, contiene pequeñas piezas que pueden soltarse.

**SE** Studera bilderna noggrant och sätt ihop delarna innan du limmar ihop dem. Skrapa noggrant bort förtkröning och färg från limmade delar. Alla delarna är numrerade. Mala smadelarna före ihopsättning. Fastsättning av dekaler, klipp arket. Doppa i varmt vatten några sekunder, låt baksidan glida på plats som bilden visar. Används i samband med kartongens handlitografi. Rekommenderas ej för barn under 3 år. Innehåller löstgåbara smadelar.

**IT** Studiare i disegni e praticare il montaggio prima di unire insieme i pezzi con l'adesivo. Raschiare attentamente le tracce di smalto e cromatura dalle superfici da unire con adesivo. Tutti i pezzi sono numerati. Colorare i pezzi di piccole dimensioni prima di montarli. Per applicare le decalcomanie, tagliare il foglio secondo il caso, immergere in acqua calda per alcuni secondi, quindi sfilare la decalcomania dalla carta di supporto e piazzarla nella posizione indicata. Usare in congiunzione con l'illustrazione sulla scatola. Non adatto ad un bambino di età inferiore ai 36 mesi dovuto alla presenza di piccoli elementi staccabili.

**NL** Tekeningen bestuderen en delen in elkaar zetten alvorens deze te lijmen. Metaalcoating en lak voorzichtig van lijmvlakken af schrapen. Alle delen zijn genummerd. Kleine delen vóór montage verven. Voor aanbrengen van stickers, gewenste stickers uit vel knippen, een paar seconden in warm water dompelen en dan van schutblad af op afgebeelde plaats schuiven. Hierbij afbeelding op doos raadplegen. Niet geschikt voor kinderen onder 3 jaar, omdat kleine deeltjes gemakkelijk kunnen losraken.

**DK** Tegningerne bør studeres, og man bør øve sig i monteringen, før delene limes sammen. Pladestykker og maling skal omhyggeligt fjernes fra kloebeoverfladerne. Alle dele er nummererede. Små dele skal males før monteringen. Overføringsbillederne anvendes ved at tilklippe arket efter behov. Og dyppe det i varmt vand i nogle få sekunder. Underlaget glides af og anbringes i den viste position. Påføres ifølge brugsanvisningerne på oesken. Ikke til børn under 3 år, forekomst af små løse elementer.











**PT** Estudar atentamente os desenhos e experimentar a montagem. Raspar cuidadosamente as superfícies de modo a eliminar pintura e revestimento antes de colar. Todas as peças estão numeradas. Pintar as pequenas peças antes de colar. Para aplicar as decalcomanias, cortar as folhas e mergulhar em água morna por alguns segundos, depois deslizar e aplicar no respectivo lugar, como indicado nas ilustrações na caixa. Não convém a uma criança de menos de 36 meses devido à presença de pequenos elementos destacáveis.

**FI** Tutustu piirroksiin ja harjoittele kokoamista ennen kuin liimaat osat yhteen. Raaputa metallipäällyste ja maali varovasti pois liimattavilta pinnoilta. Kaikki osat on numeroitu. Maalaa pienet osat ennen kokoamista. Siirtokuvien kiinnittämiseksi leikkaa ne arkista tarpeen mukaan. Kasta kuva lämpimään veteen muutaman sekunnin ajaksi, anna takapuolen liukua kuvalle osoitettuun kohtaan. Käytetään yhdessä laatikon kuvituksen kanssa. Ei suositella alle kolmivuotiaille lapsille. Paljon irrotettavaa pikkuosia.

**PL** Przed przystąpieniem do sklejania przestuduj uważnie rysunki i przećwicz składanie części. Ostrożnie zeskrub ze sklepanych powierzchni powłokę i farbę. Wszystkie części są ponumerowane. Drobne części pomaluj przed ich złożeniem. Celem przeniesienia odbitki wytnij ją z arkusza, zanurz na kilka sekund w letniej wodzie i zsuń z podłoża na wymagane miejsce. Używaj w połączeniu ze wzorami na pudełku. W związku z obecnością wielu drobnych, rozbiernych części, niestosowne dla dzieci poniżej 3 lat.

**GR** Μελετήστε προσεκτικά τα σχέδια και συναρμολογήστε για πρώτη φορά τα κομμάτια χωρίς να τα συγκολλήσετε. Αφαιρέστε επιμελώς τη μεταλλική μπιονιά και την πλαστική βαφή από τις επιφάνειες τις οποίες θα συγκολλήσετε ξυνοτάς τες προσεκτικά. Όλα τα κομμάτια είναι αριθμημένα. Χρωματίστε τα μικρά κομμάτια πριν από τη συναρμολόγηση. Για να κολλήσετε τις χαλκομανίες, κόψτε γύρω από το σχέδιο όπως απαιτείται, βυθίστε το μερικά δευτερόλεπτα σε χλιαρό νερό και μετά τοποθετήστε το στη θέση που υποδεικνύεται, αφαιρώντας τη μεμβράνη που το καλύπτει. Λάβετε υπόψη σας ταυτόχρονα την εικονογράφηση του κουτιού. Ακατάλληλο για παιδιά ηλικίας κάτω των 36 μηνών λόγω ύπαρξης μικρών κομματιών που αποσπώνται.

# ASSEMBLY ICON INSTRUCTIONS

<p>Assembly phase Phase de montage Montagephase Fase de montaje Monteringsfasen Fase di montaggio Montagefase Fase de montagem Monteringsfase Kokoamisvaihe Faza składowania Φάση συναρμολόγησης</p> 	<p>Cement Coller Kleben Pegar Limma Incollare Lijmen Colar Kleebes Liimaa Kleić Συγκολλήστε</p> 	<p>Do not cement together No pas coller Nicht kleben No pegar Limma inte Non incollare Niet lijmen Não colar Skal ikke kleebes Älä liimaa Nie kleić Μη συγκολλήσετε</p> 	<p>Indicates final location Indique l'emplacement final Zeigt Endposition Indica la ubicación definitiva Anger slutmonteringsplats Sede di montaggio finale Geeft uiteindelijke locatie aan 'Indica localização final Viser endelig placering Osoittaa lopullisen sijainnin Oznacza miejsce docelowe Υποδεικνύει τελική τοποθεσία</p> 	<p>Alternative part(s) provided Autre(s) pièce(s) fournie(s) Ersatzteil(e) mitgeliefert Se incluye(n) pieza(s) alternativa(s) Alternativ(a) del(ar) ingår Uno o più componenti alternativi forniti Alternatieve onderdelen meegeleverd Peça(s) alternativa(s) fornecida(s) Alternativ(e) del(e) medfølger Vaihtoehtoiset osat pakkauskassa Dostępne części zamienne Παρέχονται εναλλακτικά κομμάτια</p> 	<p>Repeat this operation Répéter l'opération Vorgang wiederholen Repitir la operación Upprepa åtgärden Ripetere l'operazione De verrichting herhalen Repitir a operação Manavren gentages Toista toimenpidetä Powtórzyć operację Επανάλαβετε τη διαδικασία</p> 	
<p>Decals Decalcomanias Abziehbild Calcomanías Dekaler Decalcomanie Stickers Decalcomania Billedoverføring Siirtokuvat Kalkomanie Χαλκομανίες</p> 	<p>Crystal part Pièce cristal Kristallteil Pieza de cristal Kristalldel Pezzo cristallo Kristallen onderdeel Peça de cristal Krystalstykke Kristalliosa Część kryształowa Κομμάτι κρυστάλλου</p> 	<p>Weight Lester Beschweren Lastrar Belasta Applicare un peso Verzwaren Lastrar Påfør vægt Aseta vastapaino Obciążyć balastem Επιθέστε βάρος</p> 	<p>Remove by filing Enlever avec une lime Abfeilen Eliminar con lima Ta bort genom att fila Rinuoverten con la lima Verwijderen door afvlijen Remove limando Fjern ved at file væk Poista viilaamalla Usunąć przy użyciu pilnika Αφαιρέστε λιμάροντας με λίμα</p> 	<p>Drill or pierce Percer Durchbohren Perforar Borra Trapanare o forare Boren of doorboren Furar Gennembor Poraa tai puhkaise Wywierć lub przedziurawić Τρυπήστε</p> 	<p>Cut Découper Schneiden Cortar Skär Tagliare Snijden Cortar Skär Leikkaa Przeciąć Κόψτε</p> 	<p>Humbrol paint number No peinture Humbrol Humbrol-Farbnnummer No de pintura Humbrol Humbrol färg nummer No vernice Humbrol Humbrol verfnnummer No de pintura Humbrol Humbrol malingnummer Humbrol-maalin numero Nr farby Humbrol Νούμερο χρώματος Humbrol</p> 

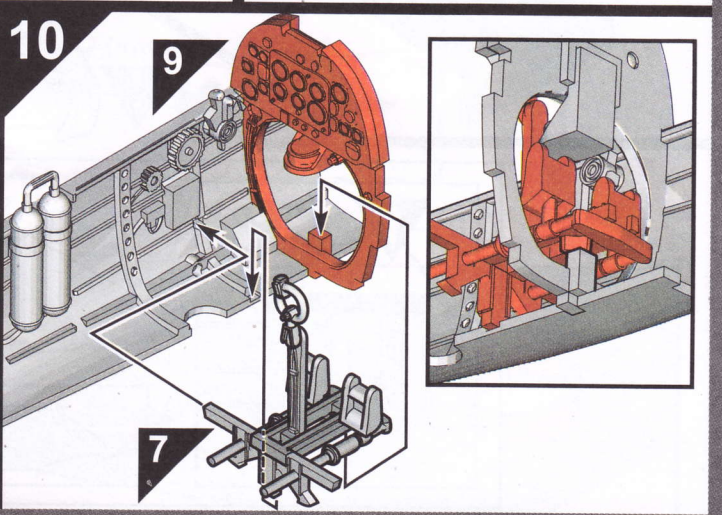
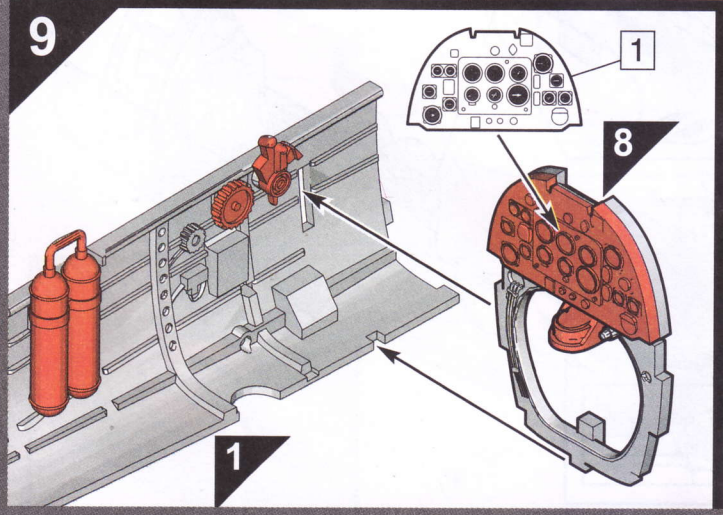
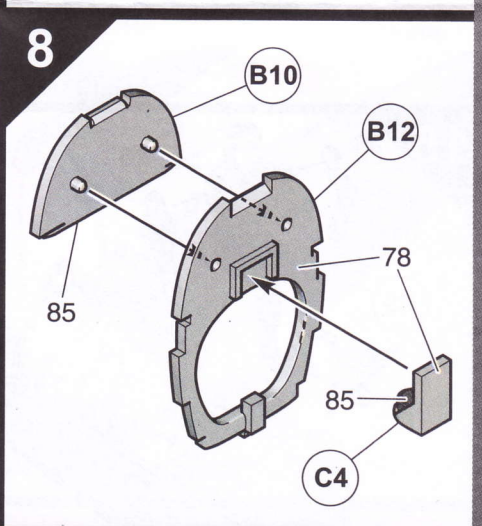
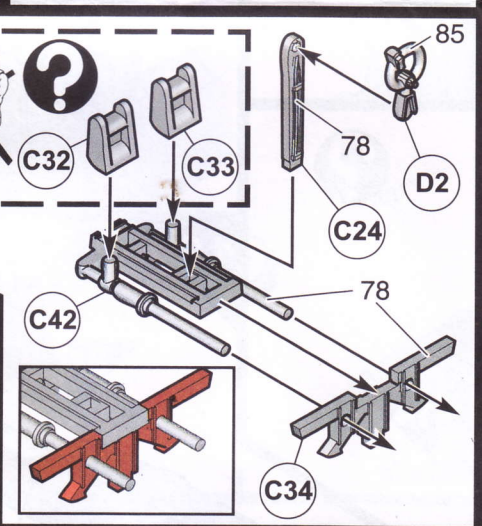
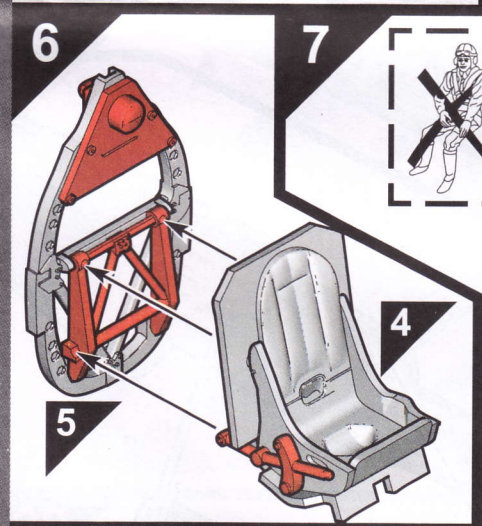
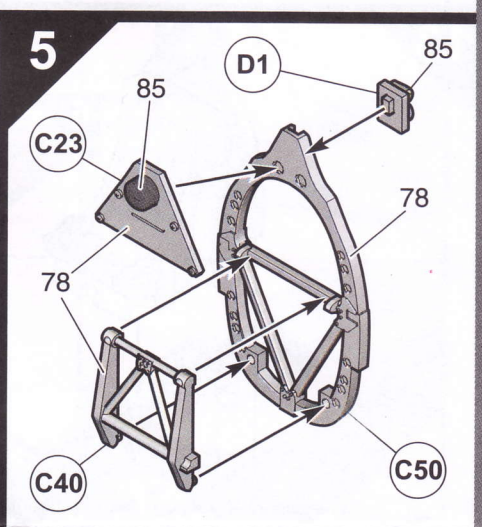
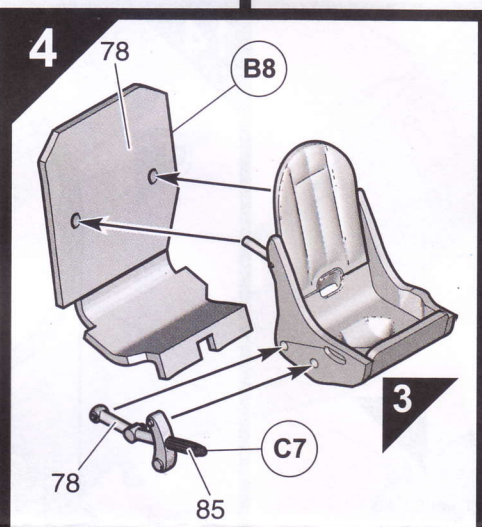
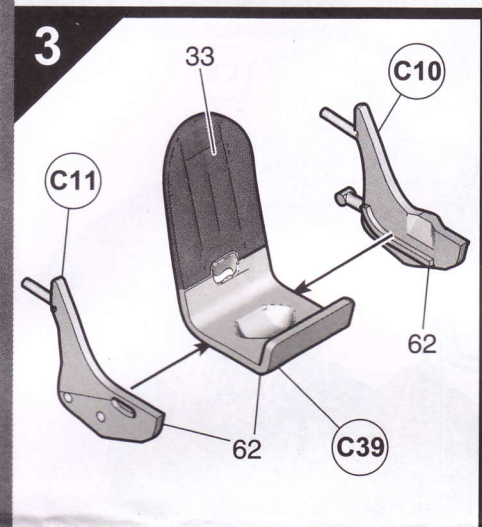
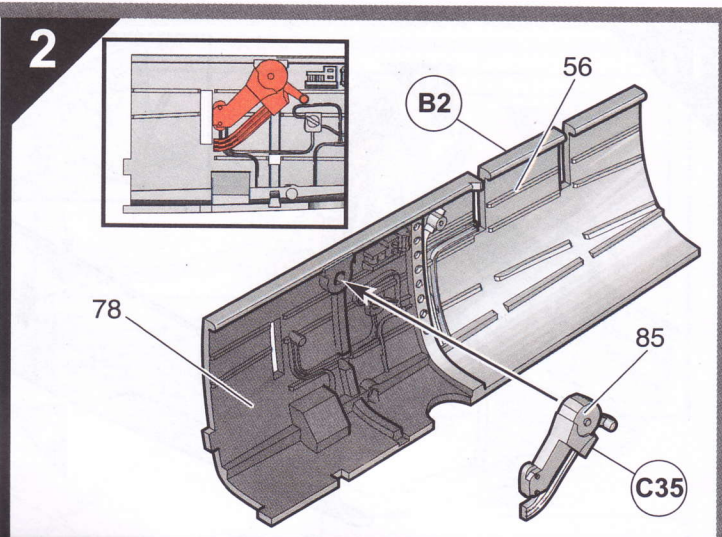
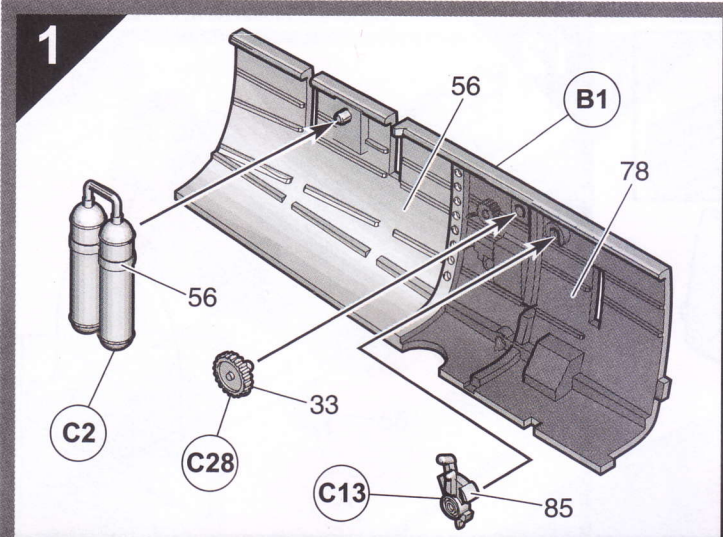

11

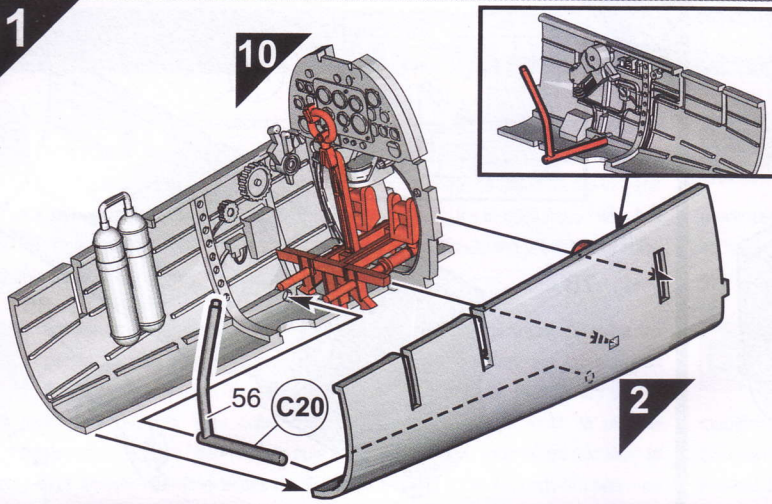

12

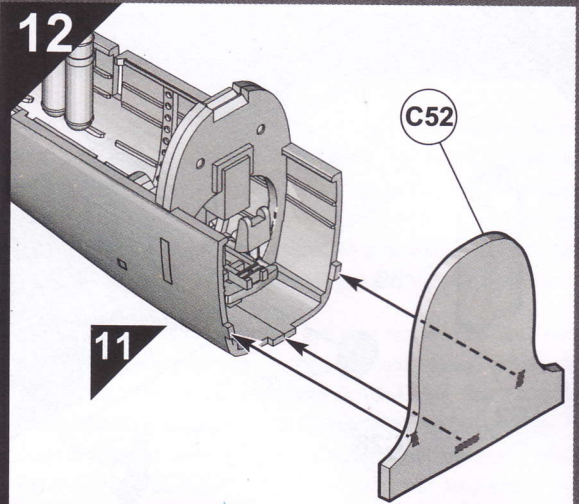

13

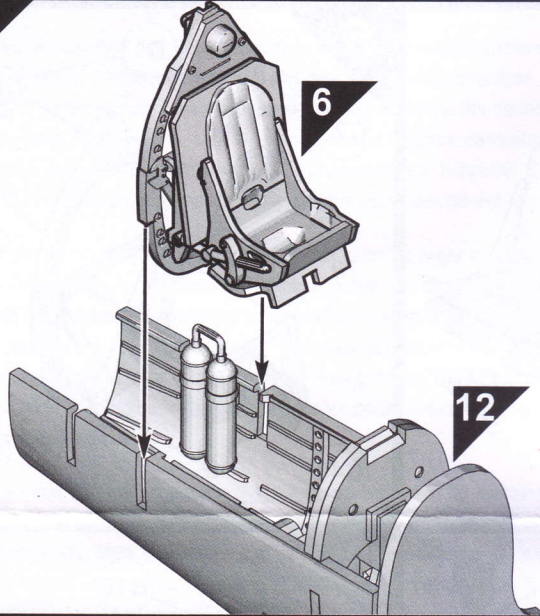

14

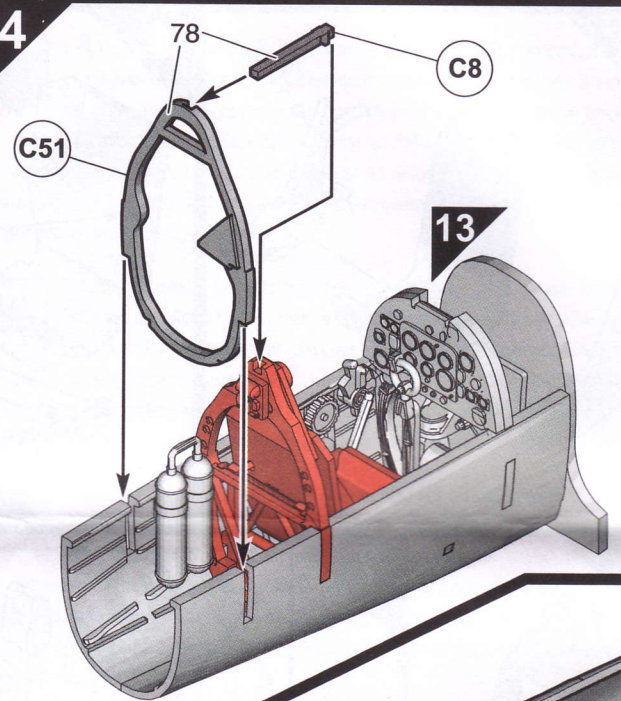

15

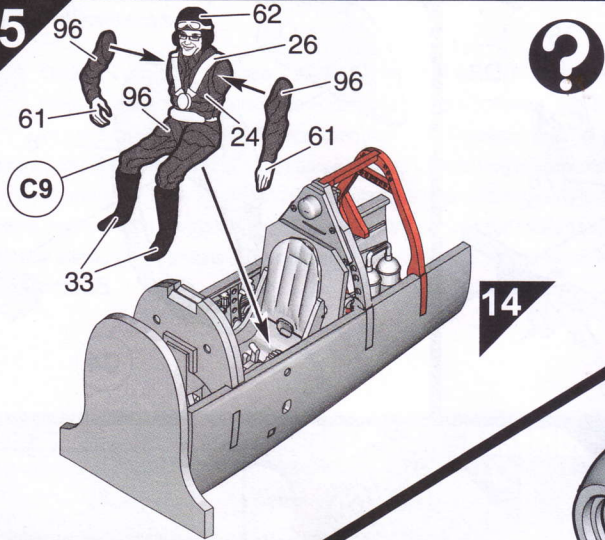

16

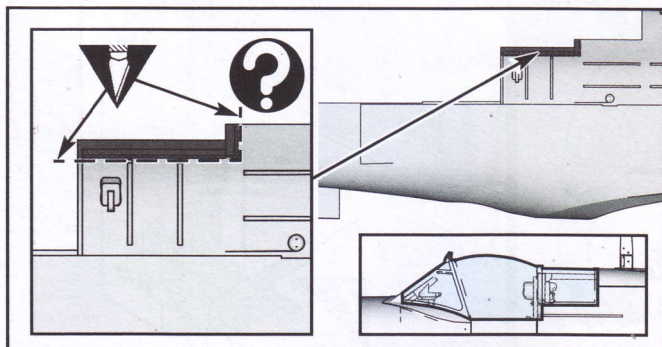
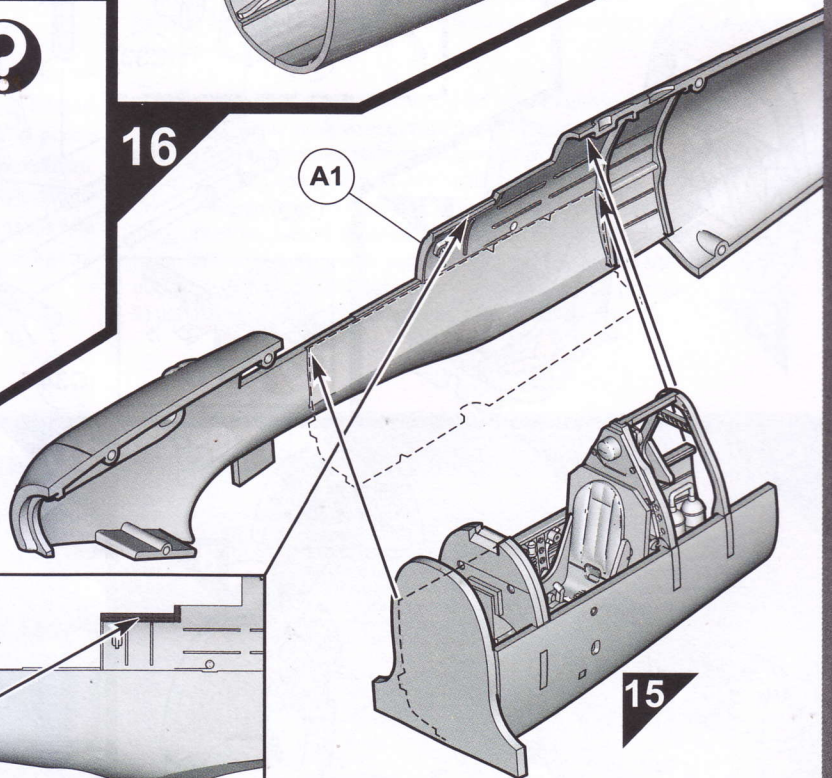

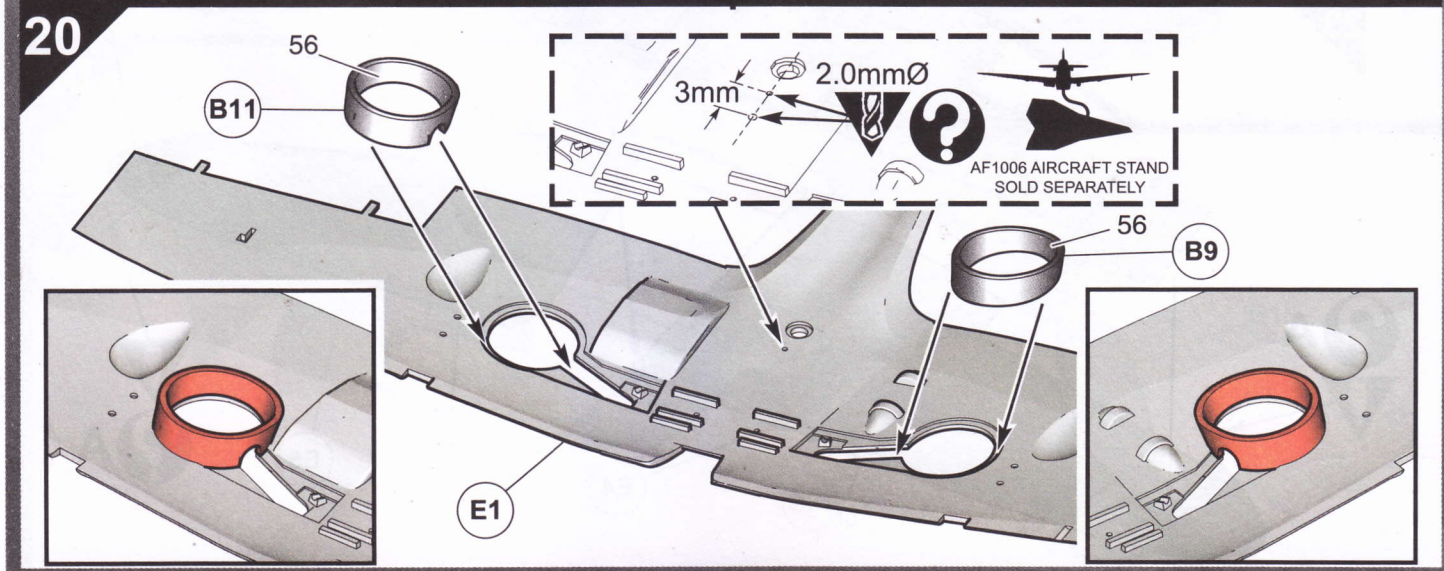
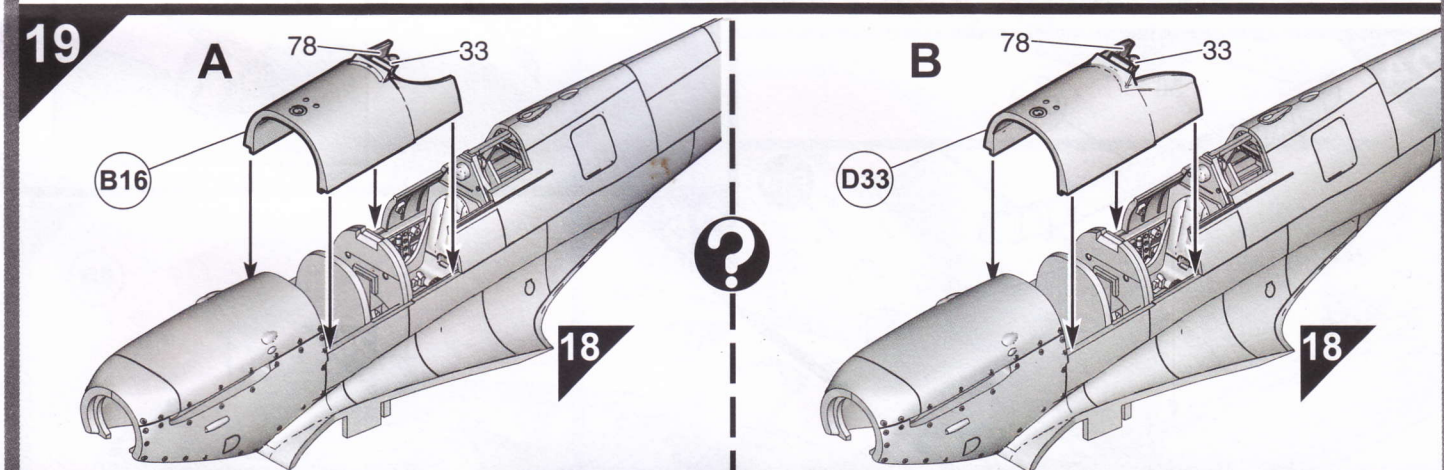
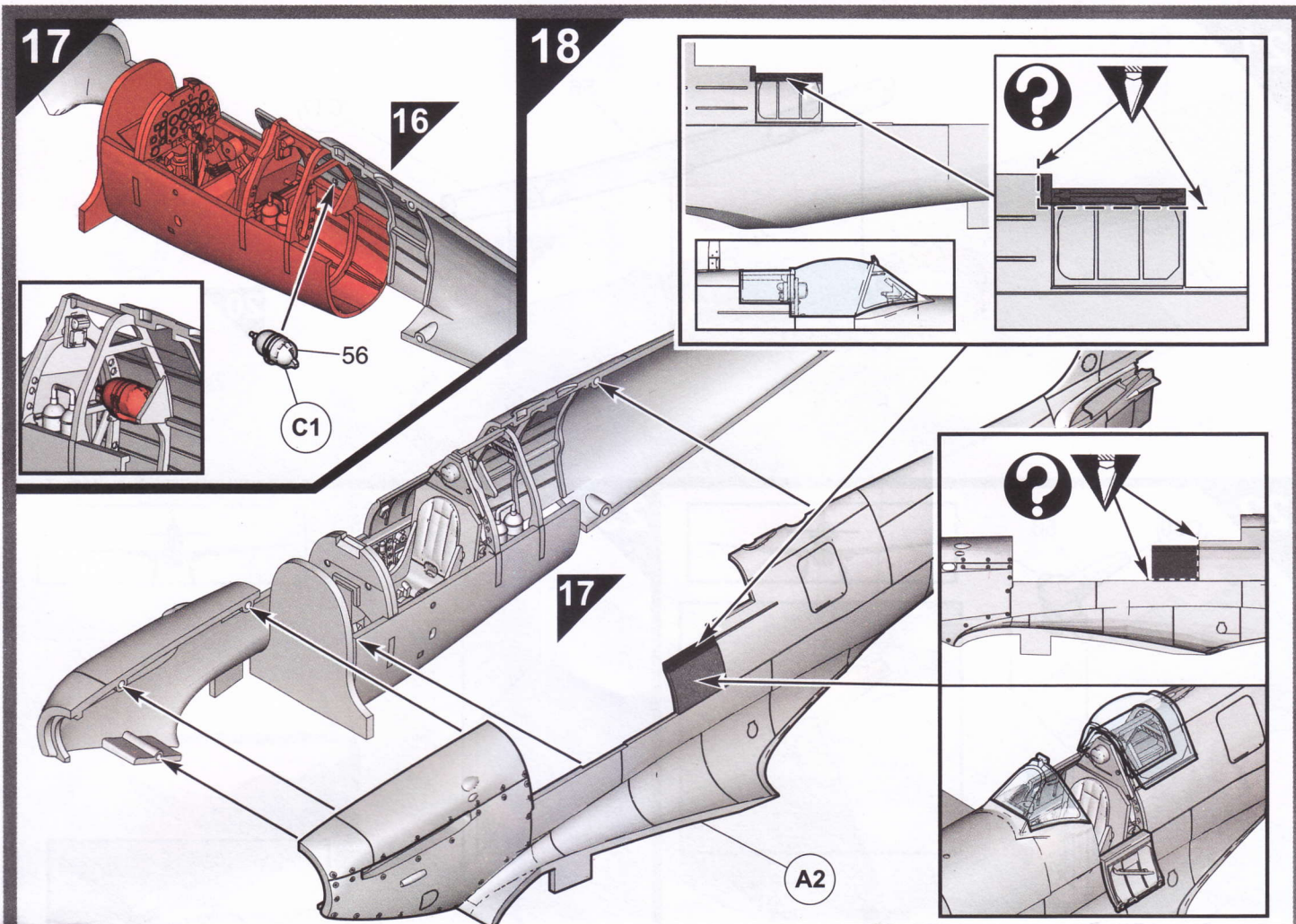

21

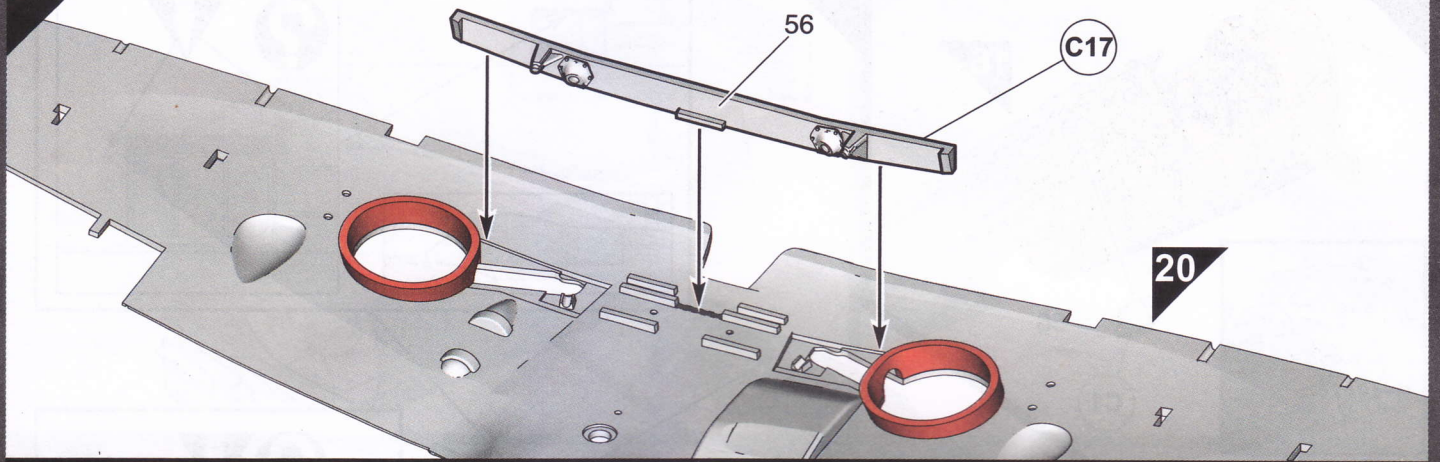

22

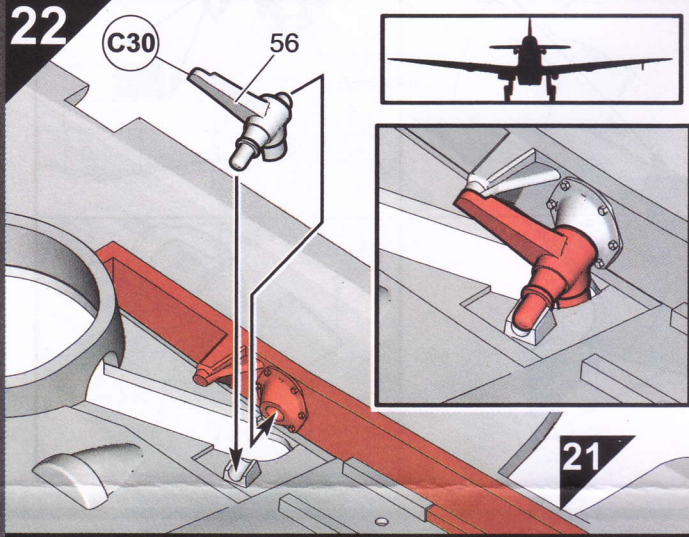

23

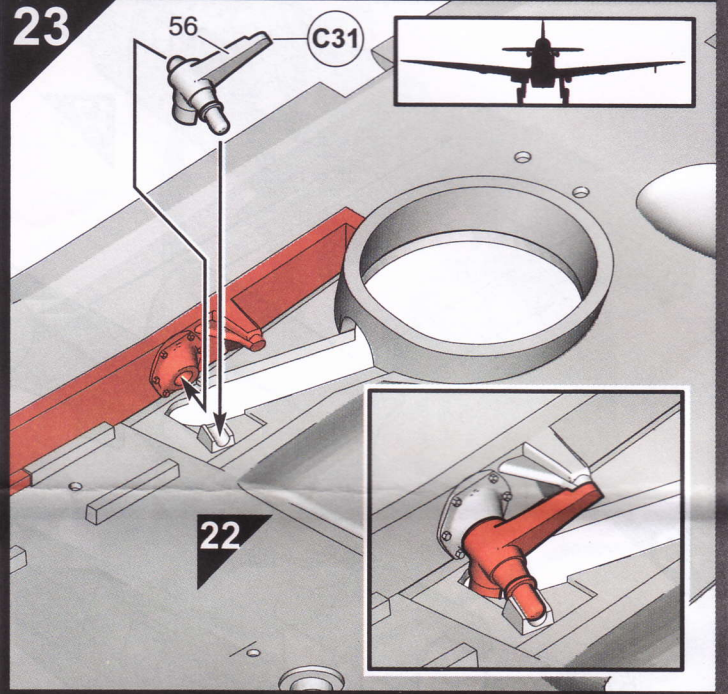

24

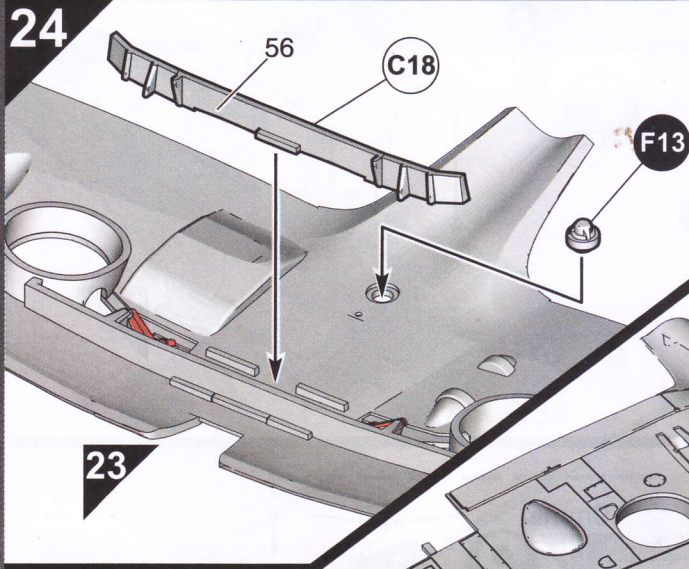

25

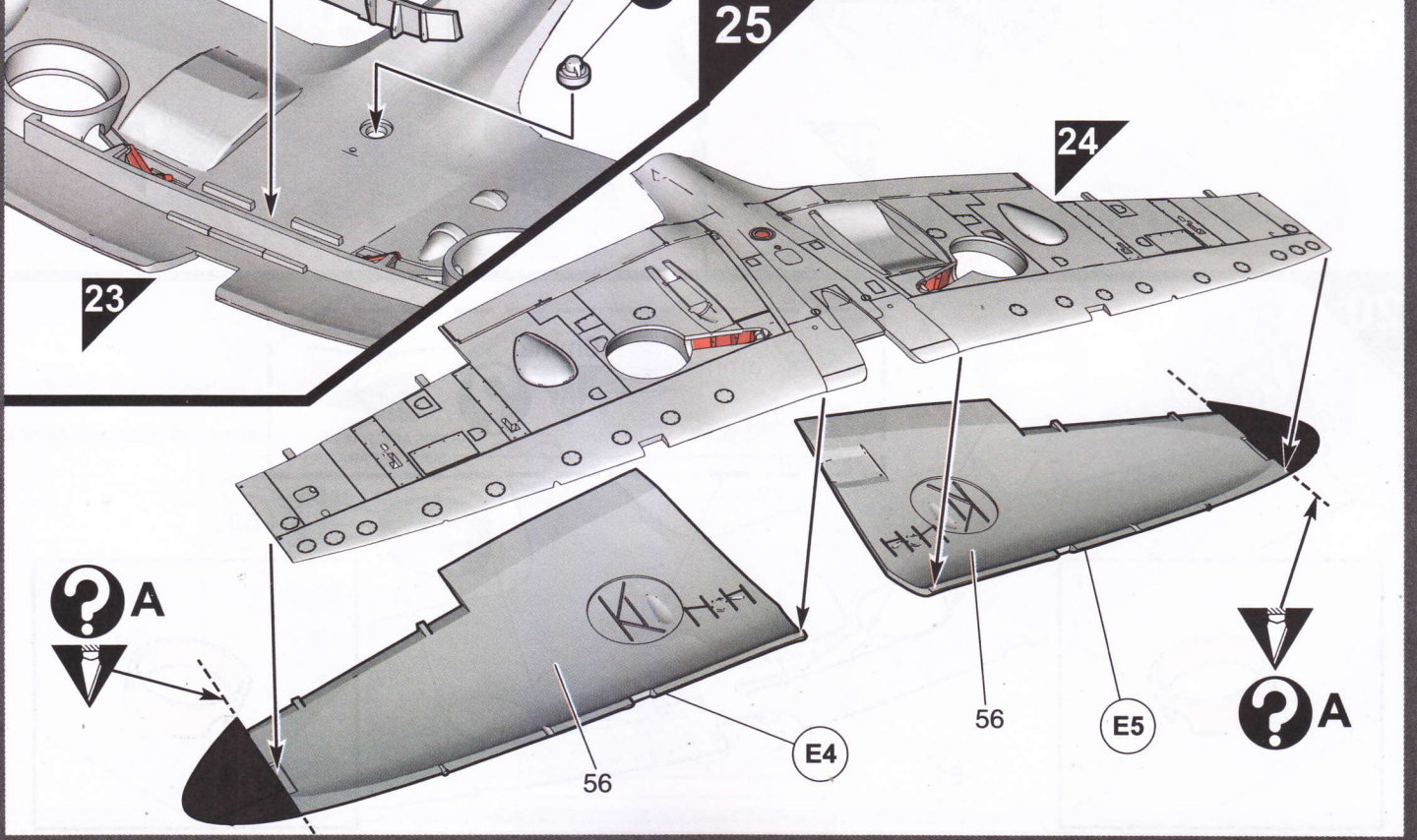

? A

F17

19

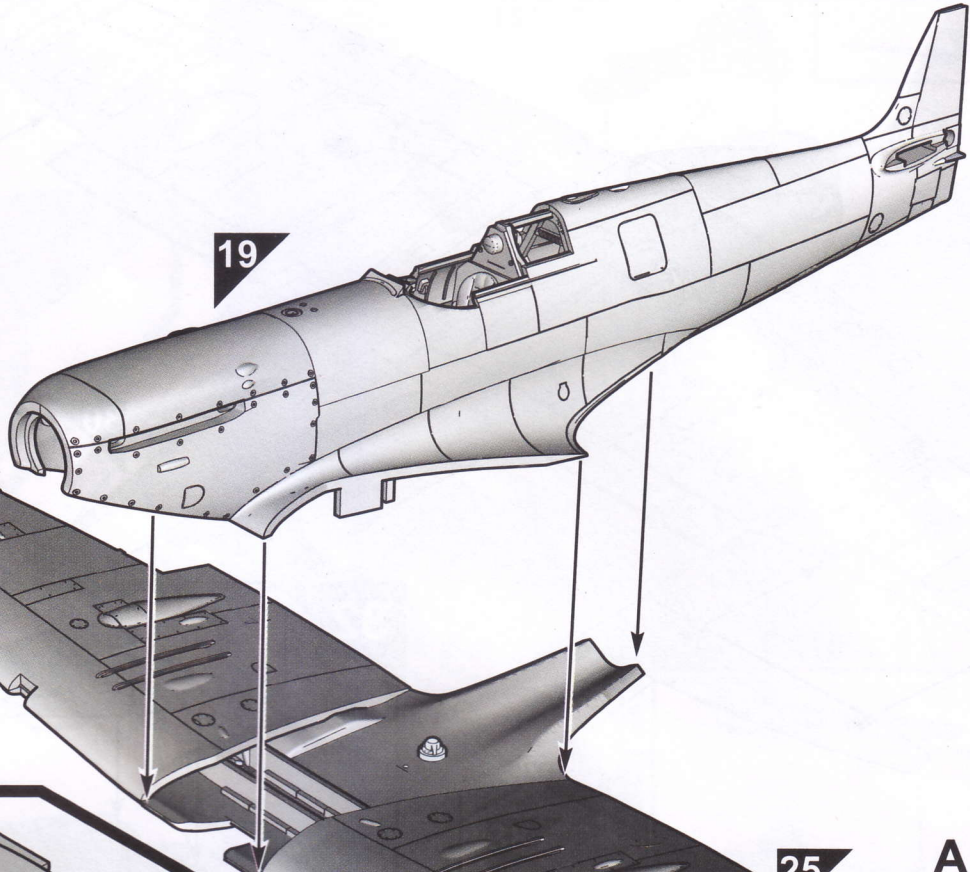

27

B7

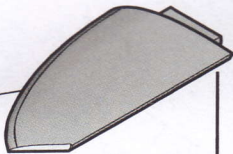

B6

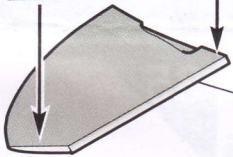

25

A ?

F16

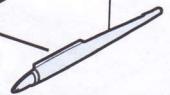

28

B5

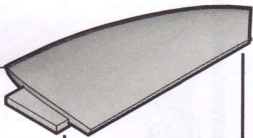

B4

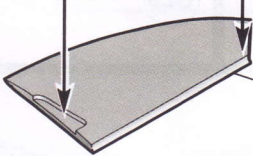

29

26

28

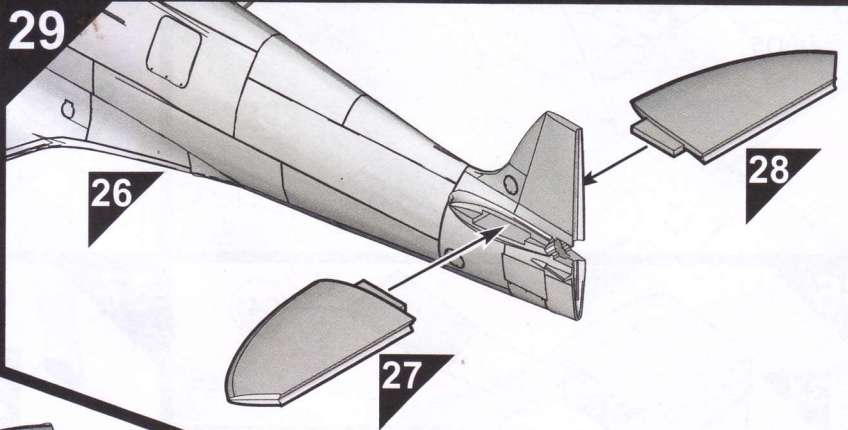

30

B3

29

B15

C25

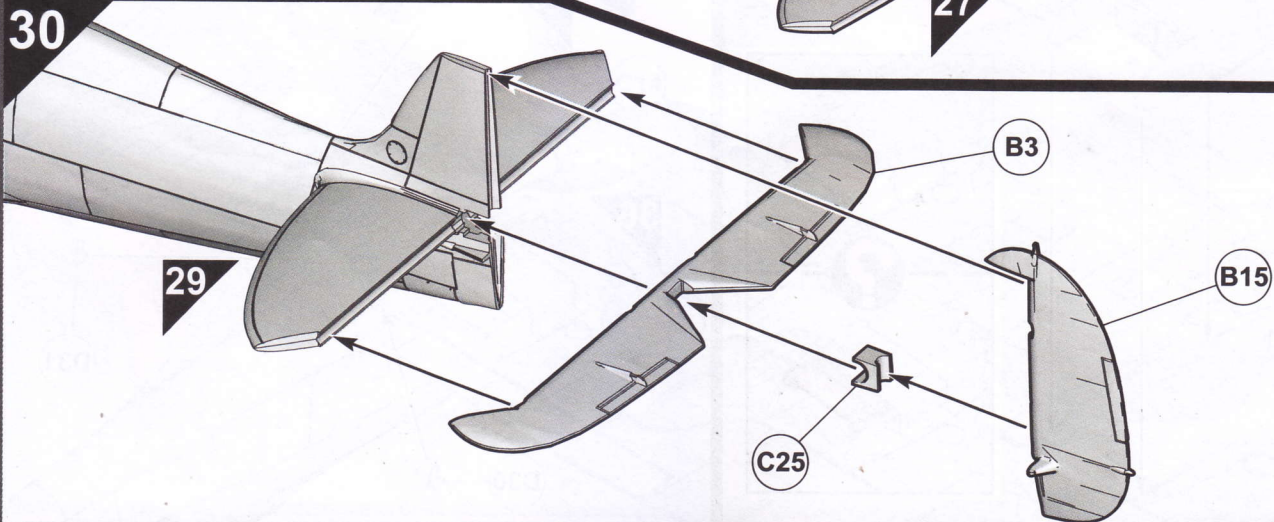

31

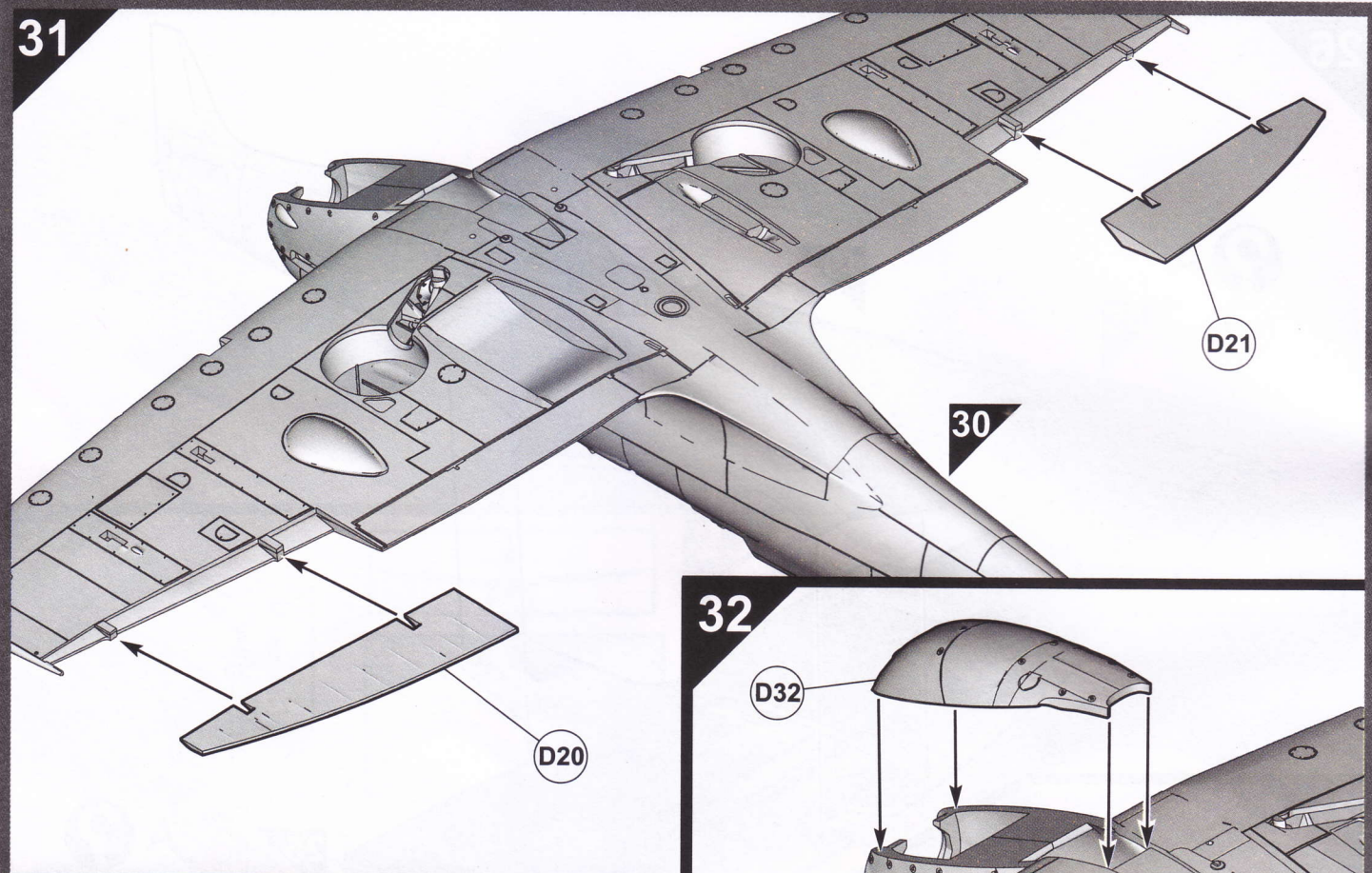

32

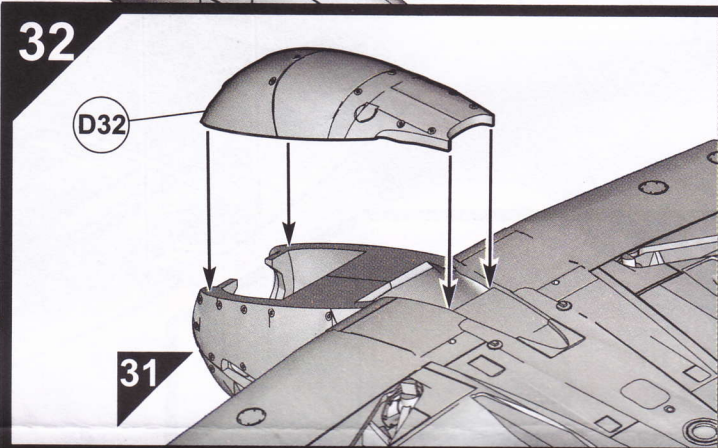

33

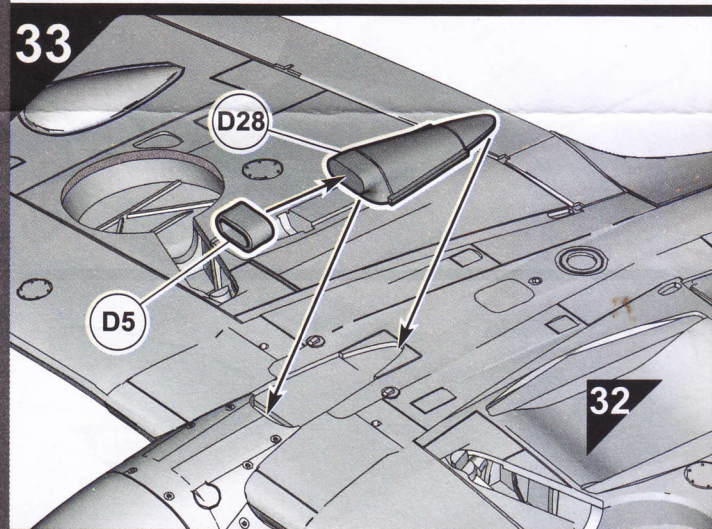

34

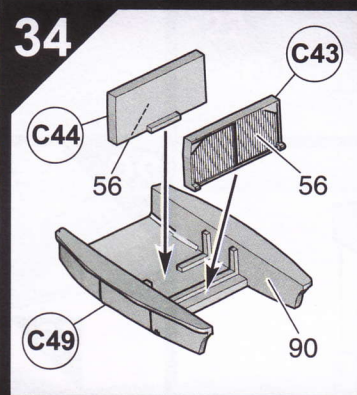

35

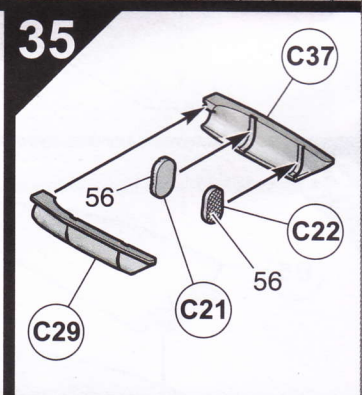

36

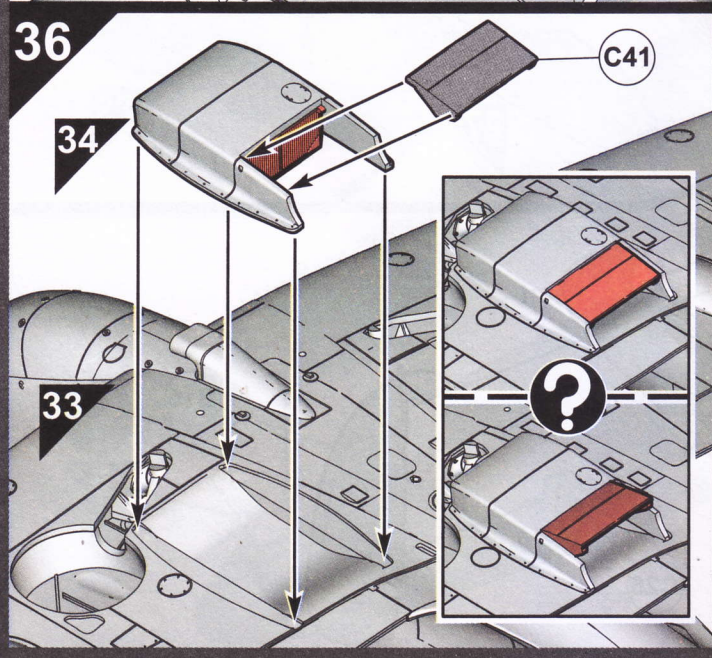

37

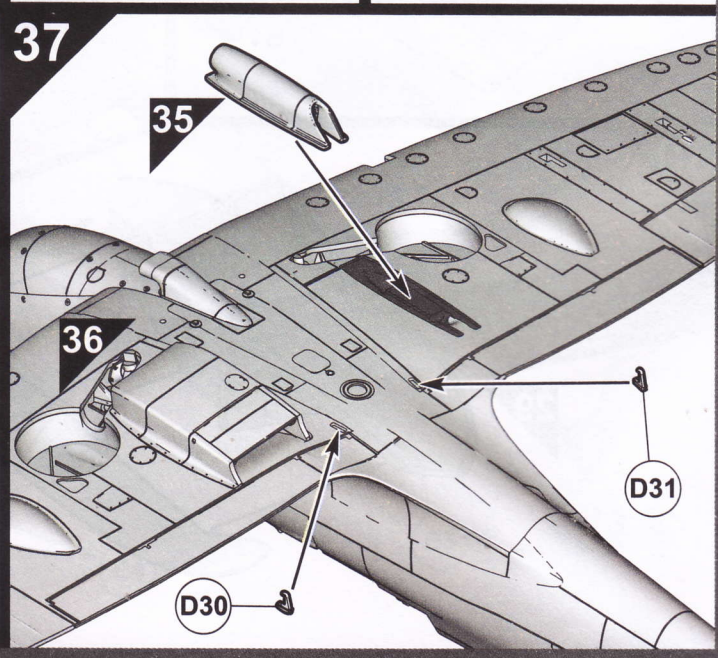



38

B17

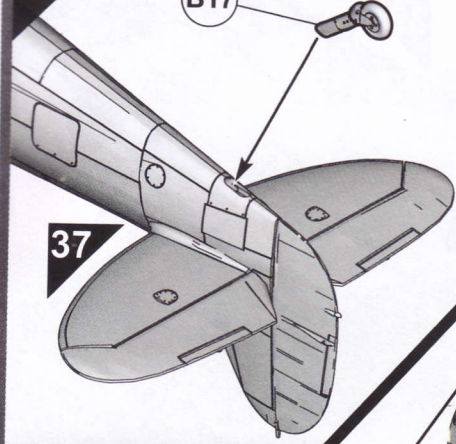

39

C15

C16

C46

56

33

33

56

C45

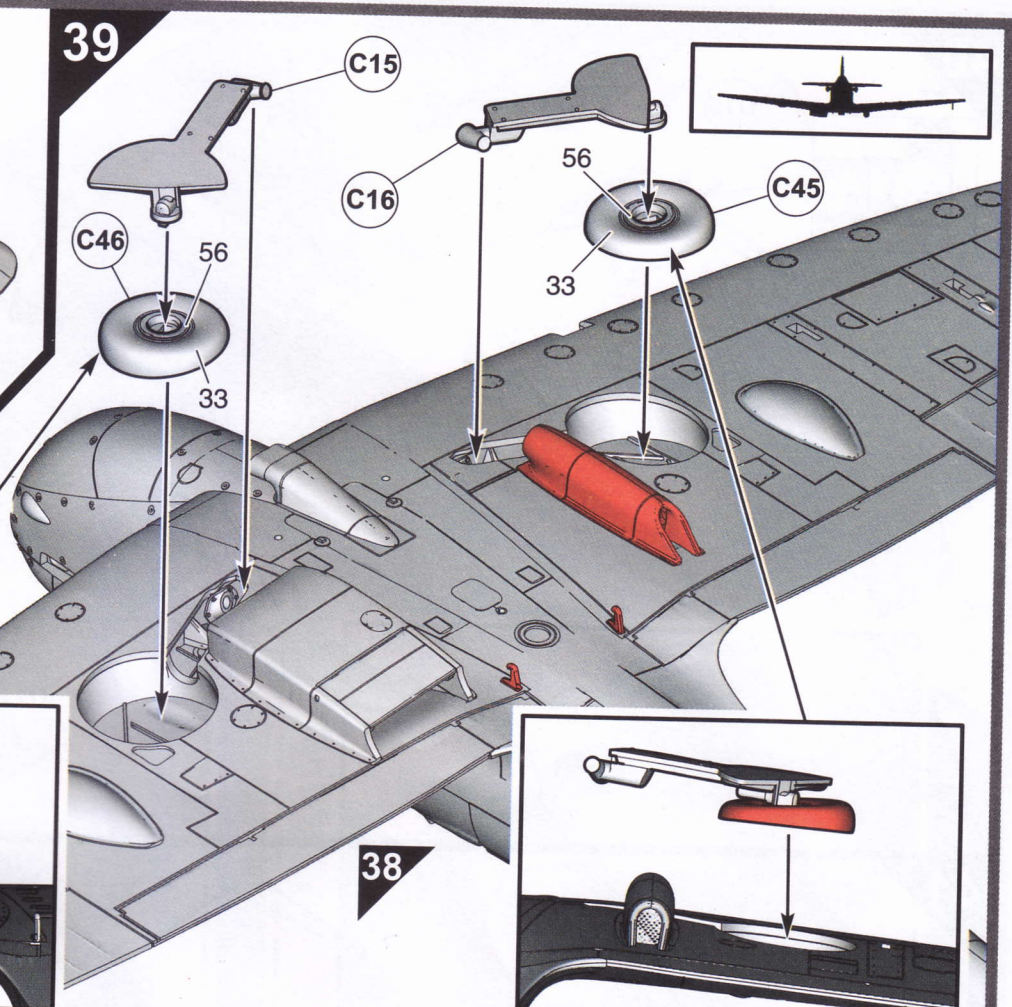

37

38

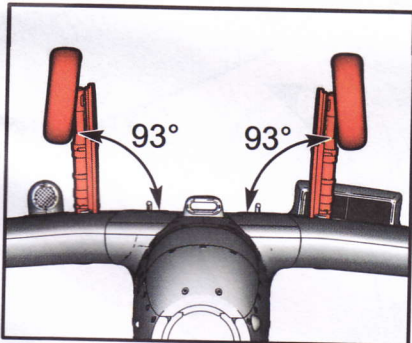
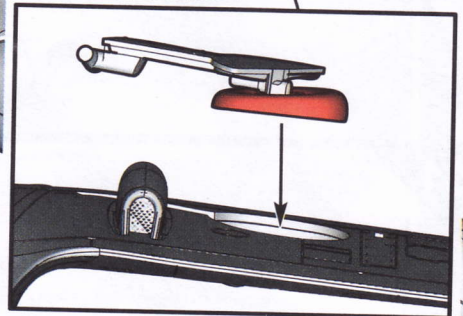
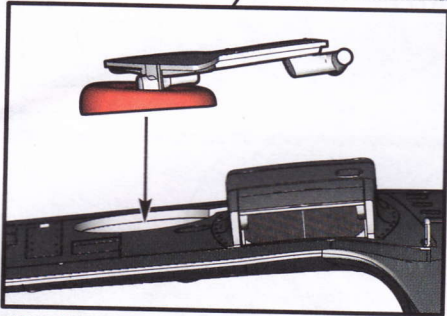

C12

56

33

C26

C36

C47

38

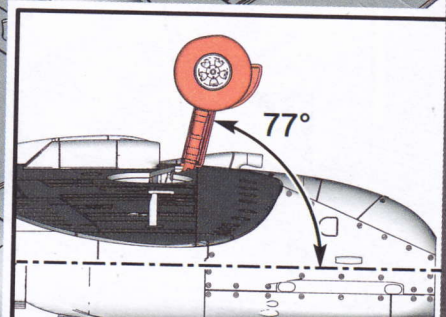
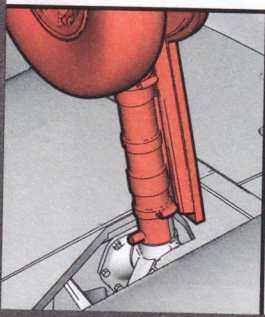
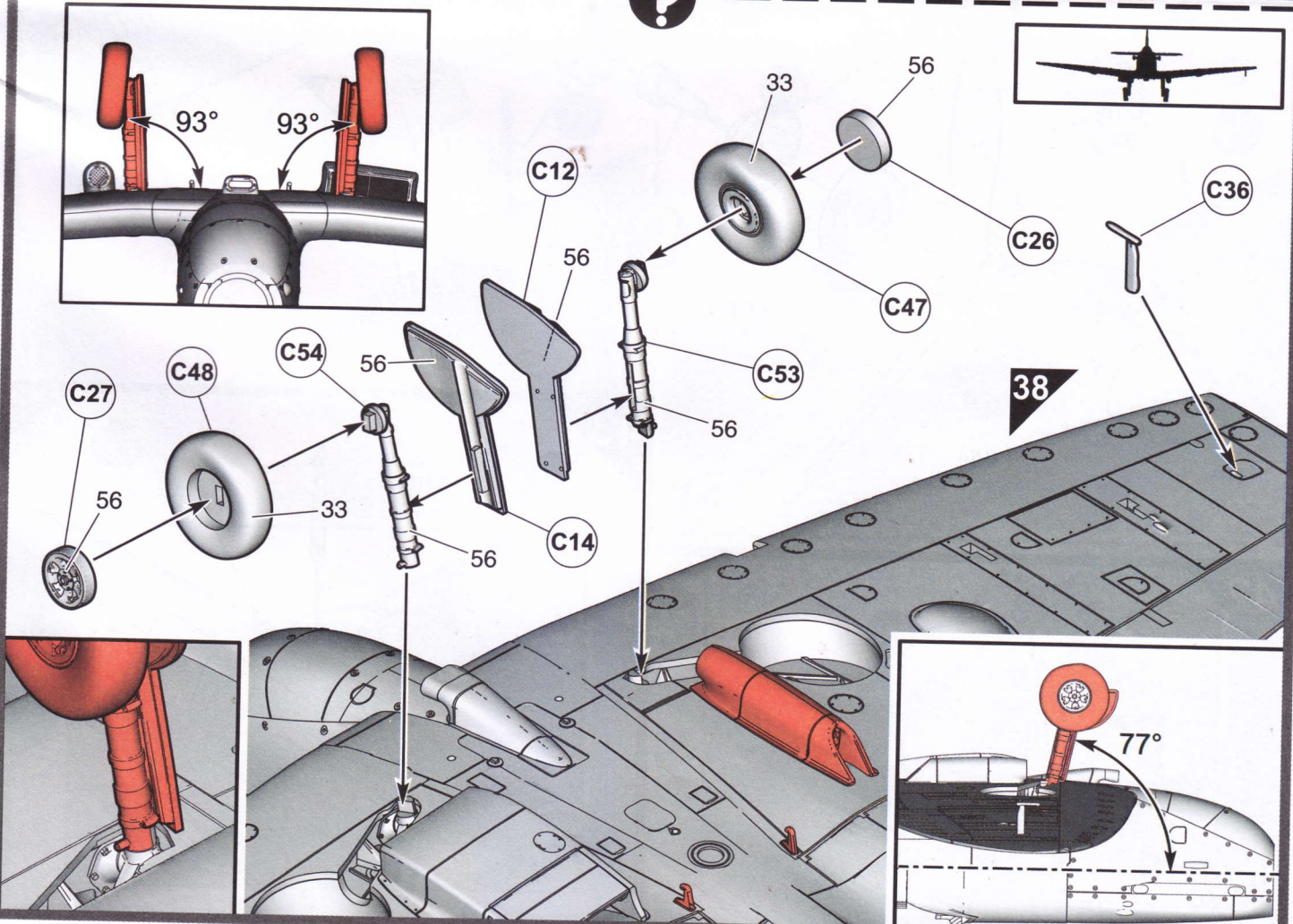

40

39

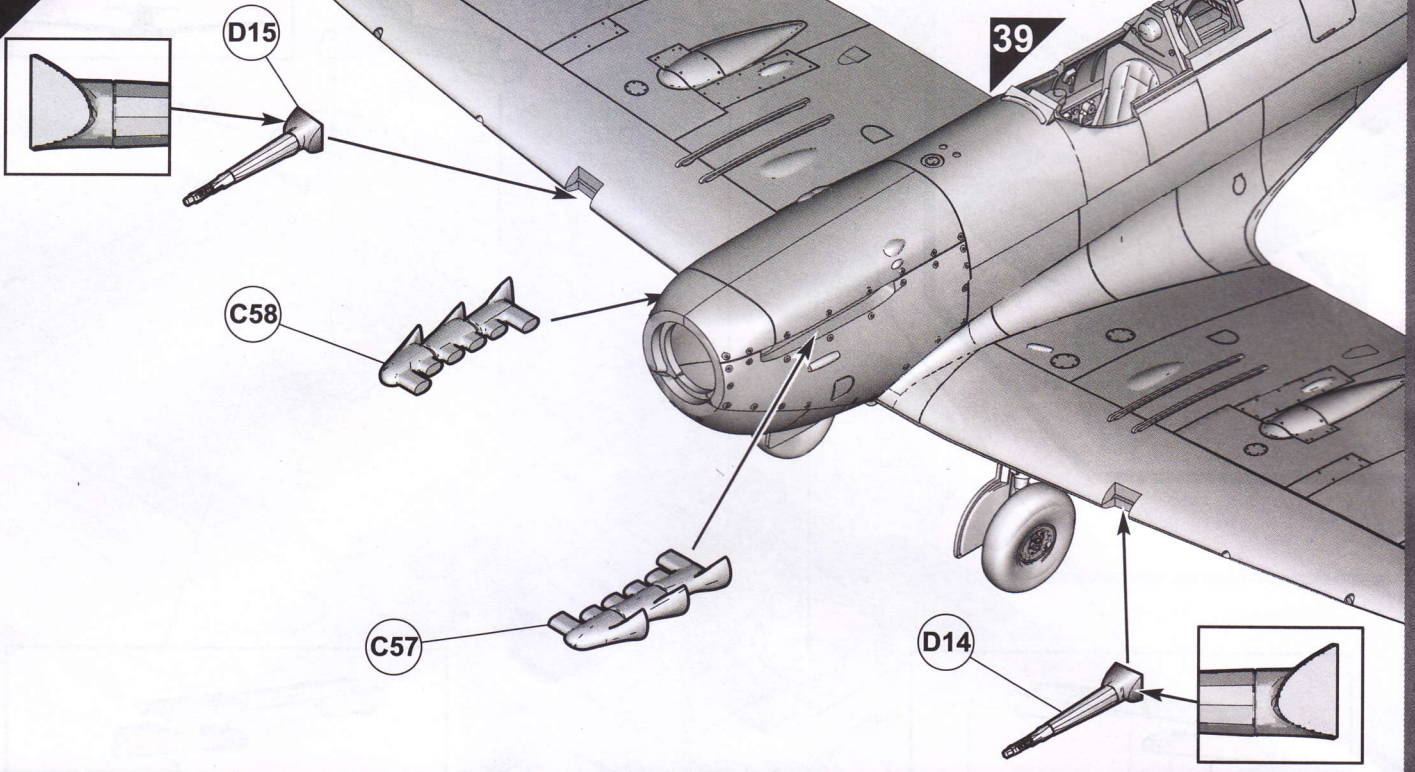

41

40

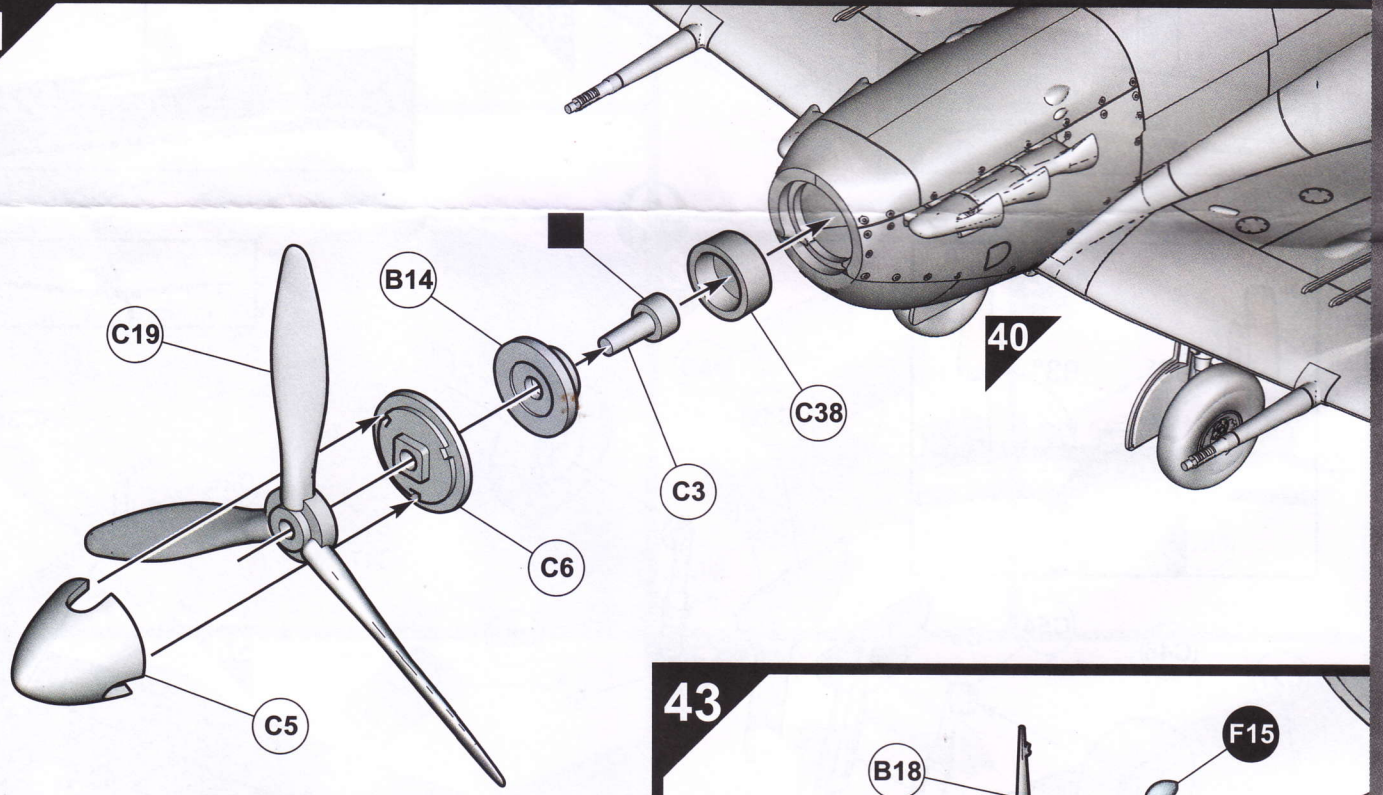

42

41

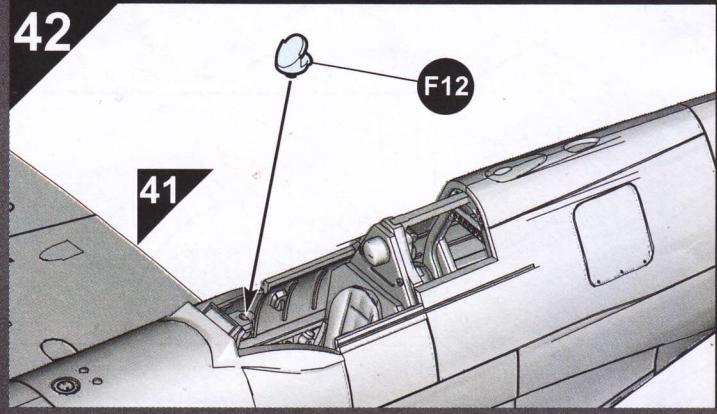

43

42

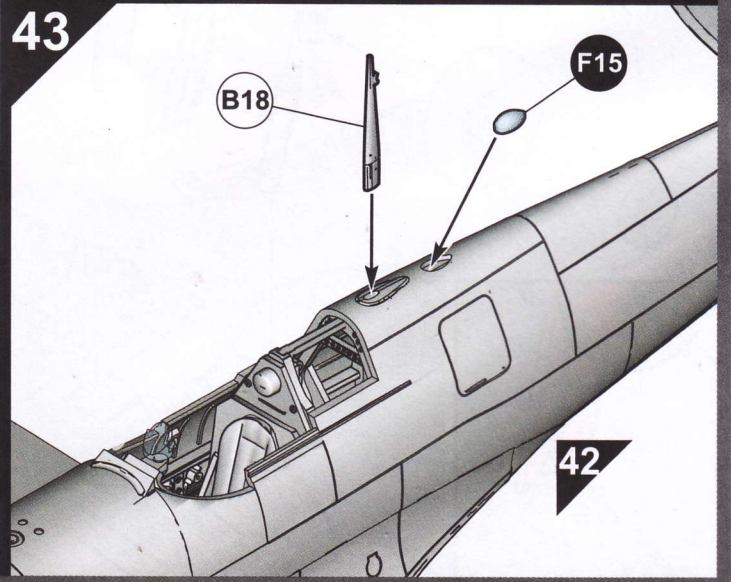

44

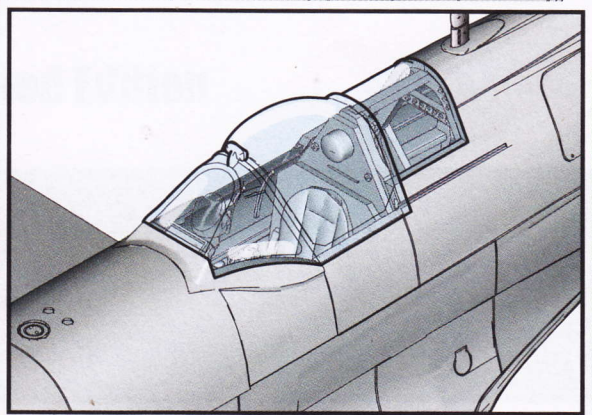
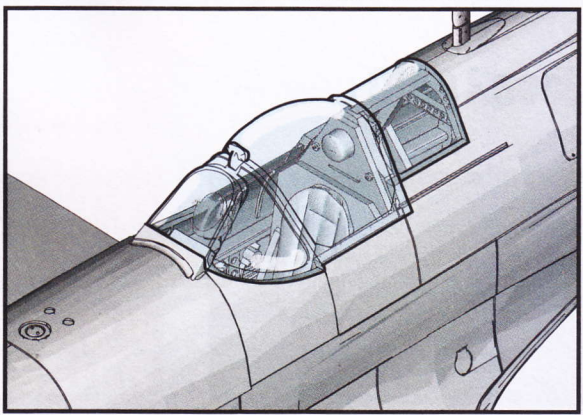
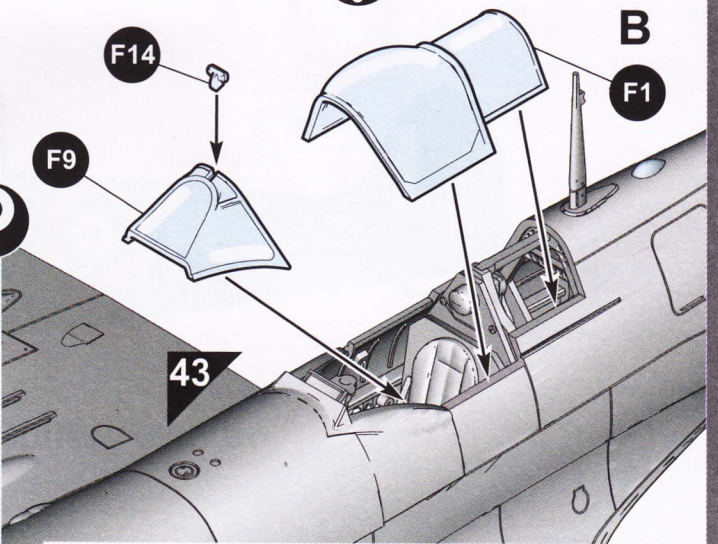
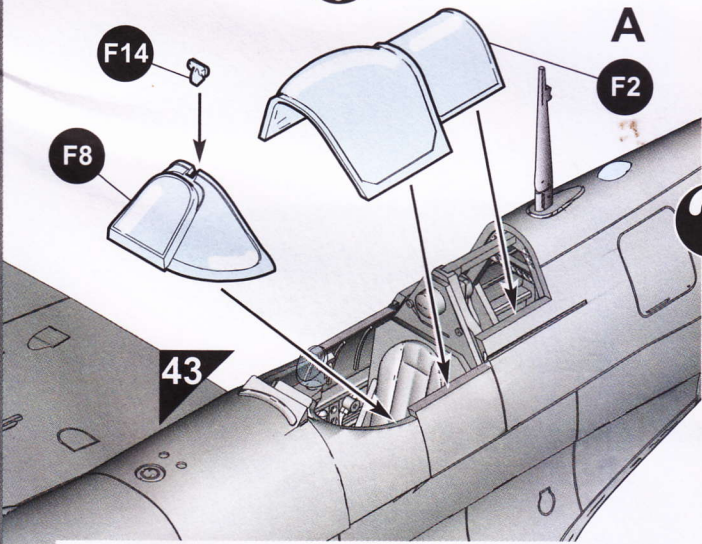
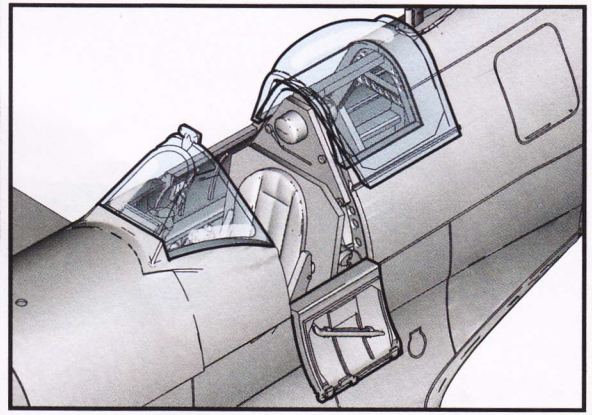
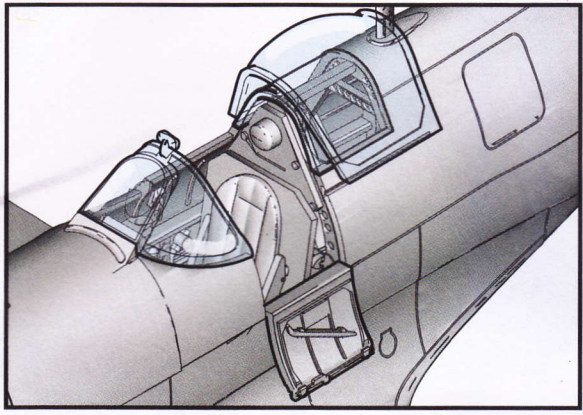
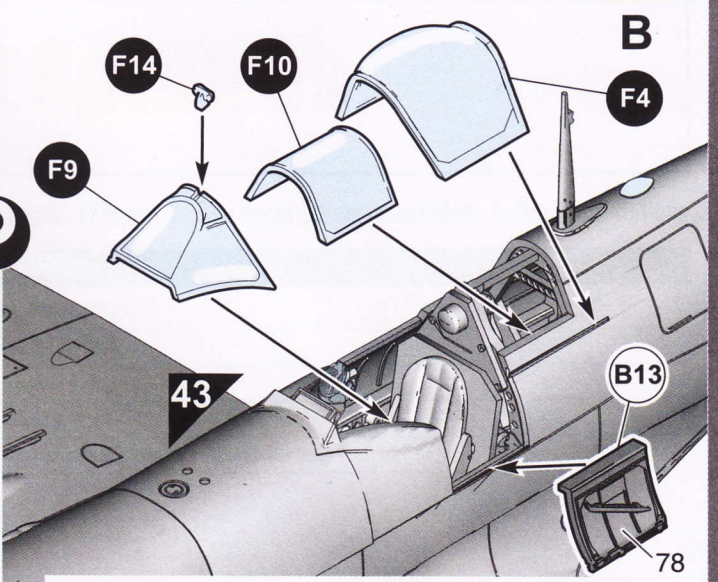
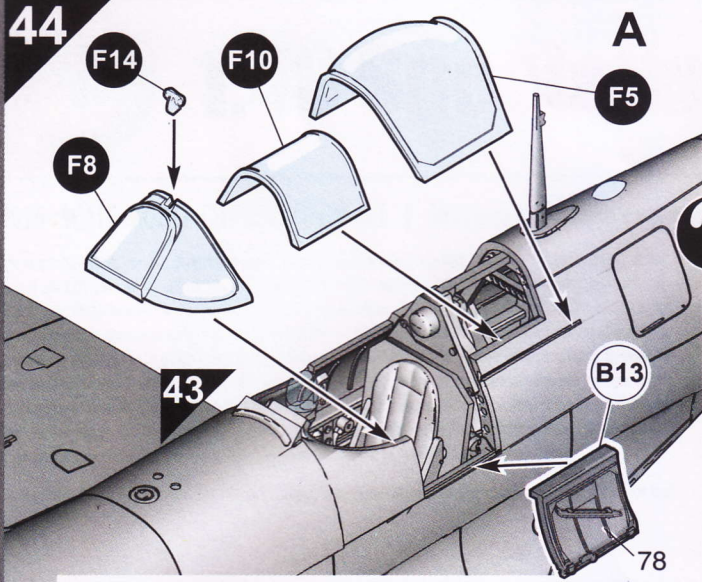

# A Supermarine Spitfire LF.Mk.Vb

Air Sea Rescue, No.278 Squadron, Royal Air Force Martlesham Heath, Suffolk, England, 1944.

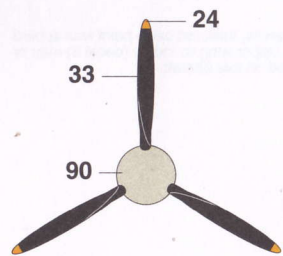
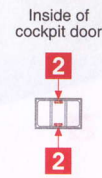
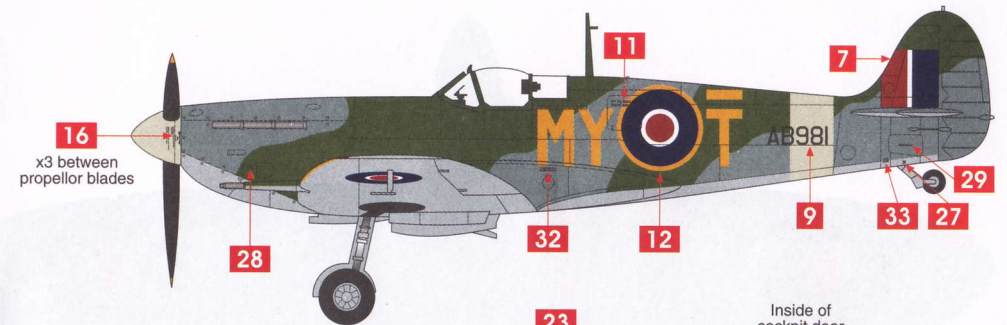
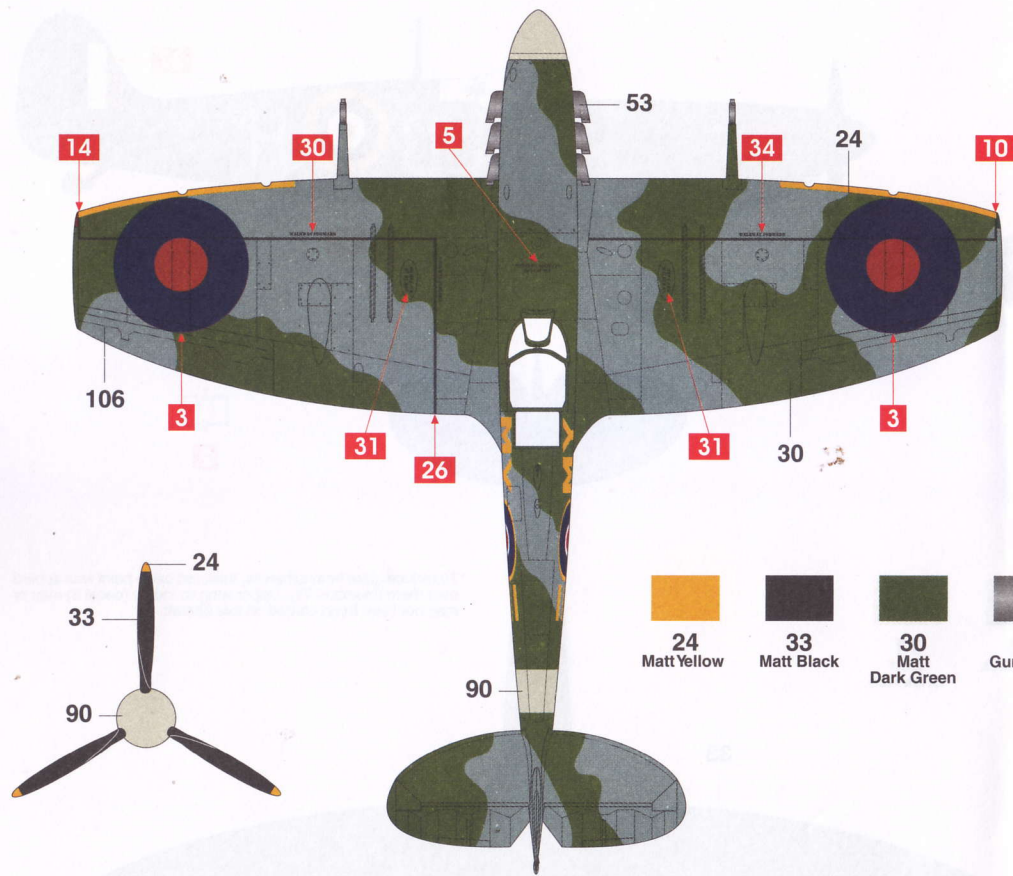

						
24 Matt Yellow	33 Matt Black	30 Matt Dark Green	54 Gun Metal	90 Matt Beige Green (approx. Sky)	106 Matt Ocean Grey	165 Medium Sea Grey

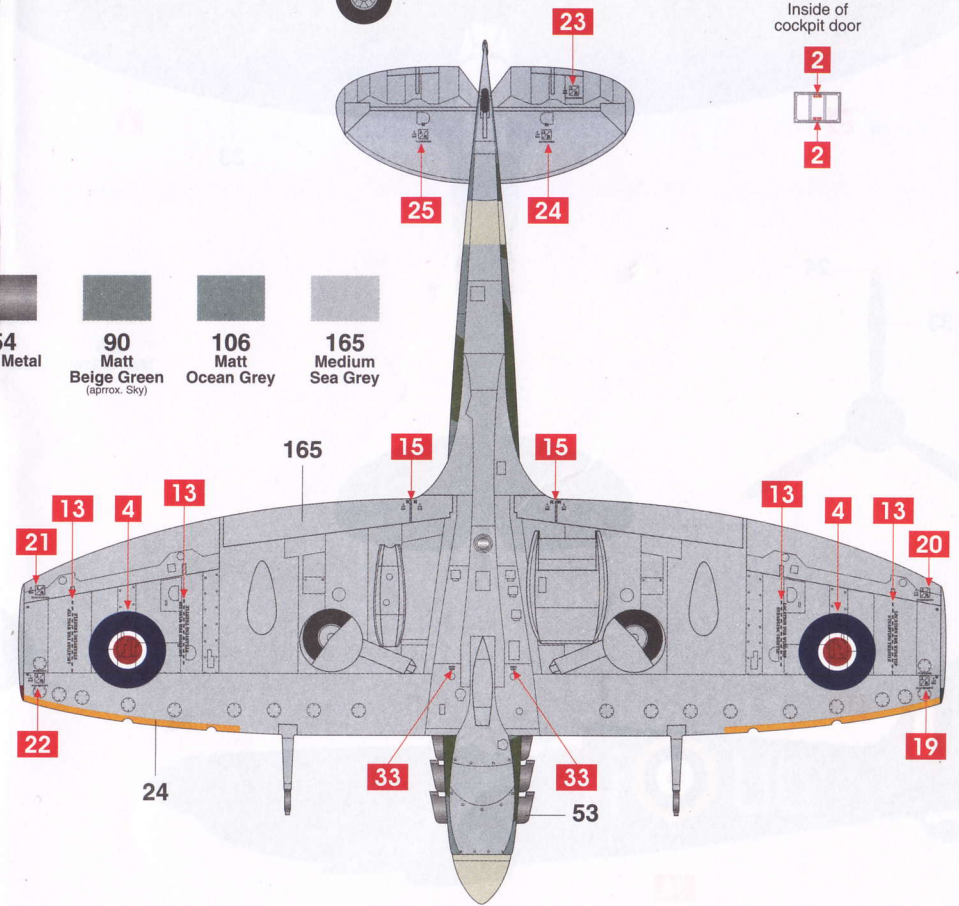
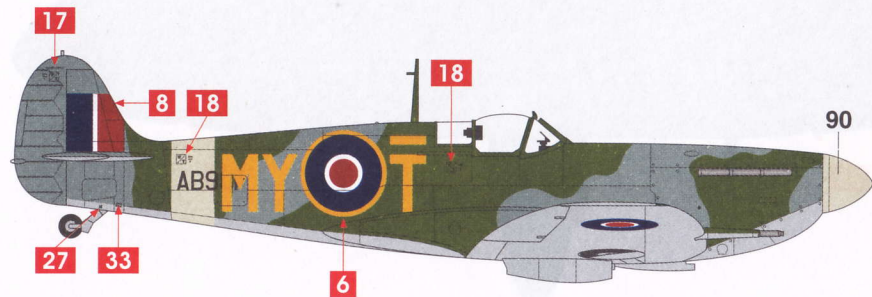

## B Supermarine Spitfire Mk.Vb

Aircraft flown as night fighter by Sergeant Peter Durnford, No.111 Squadron, Royal Air Force Debden, Essex, England, December 1941.

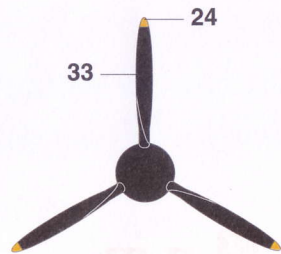
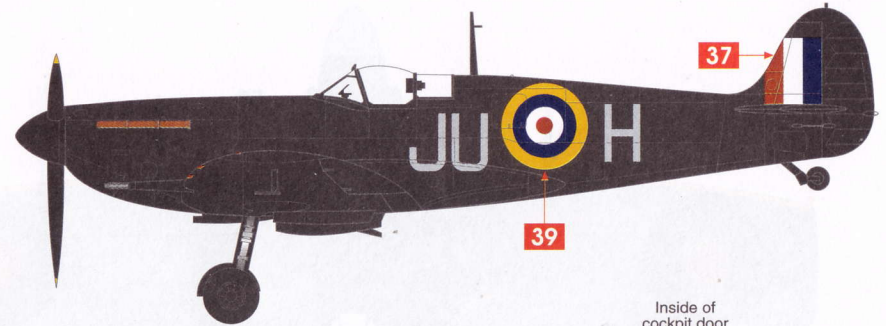
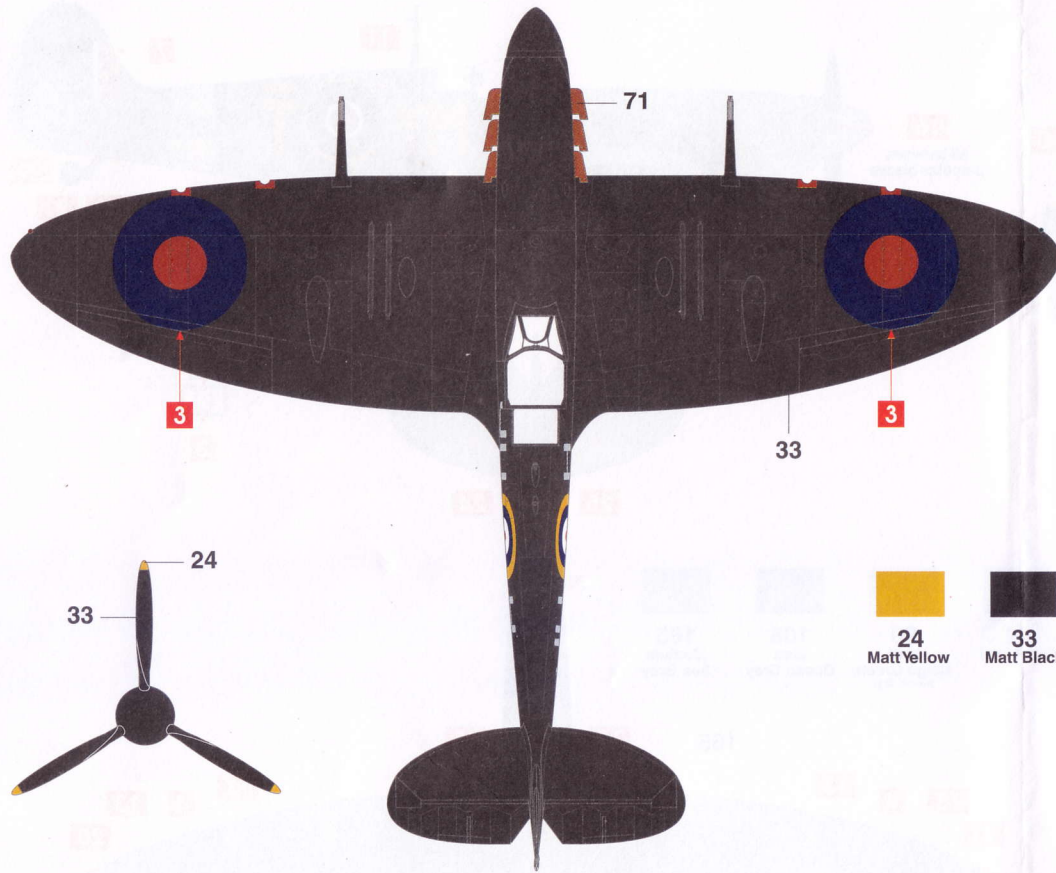

To reduce glare from exhausts, thick red oxide paint was applied over them (Humbrol 71). Upper wing roundels (decal 3) may or may not have been carried on this aircraft.

