

# Curtiss Condor

1/81 scale



Box Art by John Amendola

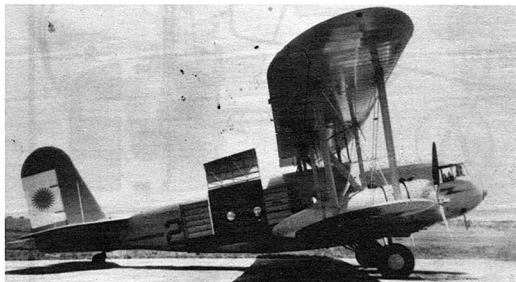

Photo: NASM

The Curtiss-Wright Model 32 Condor was the last American biplane airliner. The original Condor airliner was a direct development of the Curtiss B-2 Condor bomber of the early 1930's. The new Model 32 was a completely different design. Forty-five of the aircraft were produced in five versions, one type carrying up to 15 passengers. The first machine flew on January 30, 1933, and was delivered to Eastern Air Lines. Aircraft No. 2 went to American Airways four months later.

The Condor proved quite able and clearly had a good future, but it had the misfortune of arriving on the scene at almost the same time as the revolutionary Douglas DC-1. Production of the Condor ended in October, 1934, but the type was assured a place in history due to the service rendered during Admiral Richard E. Byrd's historic trip to Antarctica during 1933-35.

Several of the planes were operated by Chinese, Peruvian, Colombian and Argentinian military services. At least one of the planes remained in service into the 1950's.

## BRITAIN

"CAUTION: NOT SUITABLE FOR CHILDREN UNDER 3 YEARS. CONTAINS SMALL PARTS."

## FRENCH

CERTAINS PRODUITE CONTIENNENT DES PIÈCES DE PETITE DIMENSION QUI NE CONVIENT PAS A UN ENFANT DE MOINS DE 36 MOIS.

## GERMANY

VORSICHT: NICHT FÜR KINDER UNTER 36 MONATEN- ERTHÄLT KLEINE TEILE.

## ITALY

PRODOTTO NON ADATTO AI BAMBINI DI ETA INFERIORE AI 36 MESI. CONTIENE PICCOLLO OGGETTI.

## HOLLAND

KAN GEVAAR OPLEVEREN VOOR KINDEREN TOT 3 JAAR. BEVAT KLEINE UNDERDELEN.

## PORTUGAL

ATENÇÃO: IMPRÓPRIO PARA CRIANÇAS COM MENOS DE 3 ANOS. CONTÉM PEÇAS PEQUENAS.

## SPAIN

ATENCIÓN: NO ES CONVENIENTE PARA NIÑOS MENORES DE 3 AÑOS. CONTIENE PIEZAS PEQUENAS.

## DENMARK

FORSIGTIG! IKKE EGNET TIL BORN UNER 3 AR. INDEHOLDER SMA DELE.

## GREECE

ΠΡΟΣΟΧΗ: ΔΕΝ ΕΙΝΑΙ ΚΑΤΑΛΗΛΟ ΓΙΑ ΠΑΙΔΙΑ ΚΑΤΩ ΤΩΝ ΤΡΙΩΝ ΕΤΩΝ ΠΕΡΙΕΧΕΙ ΜΙΚΡΑ ΤΕΜΑΧΙΑ.

ENGLISH	FRENCH	GERMAN	SPANISH	ITALIAN
WHITE	BLANCO	WEISS	BLANC	BIANCO
YELLOW	JAUNE	GELB	AMARILLO	GIALLO
RED	ROUGE	ROT	ROJO	ROSSO
BLUE	BLEU	BLAU	AZUL	BLU
GRAY	GRIS	GRAU	GRIS	GRIGIO
GUNMETAL	METALLIC	METALLIC	METALICO	METALLICO
GREEN	VERT	GRÜN	VERDE	VERDE
SILVER	ARGENT	SILBERN	PLATA	ARGENTO
BLACK	NOIR	SCHWARTZ	NEGRO	NERO

### ADDITIONAL GLENCOE PARTS

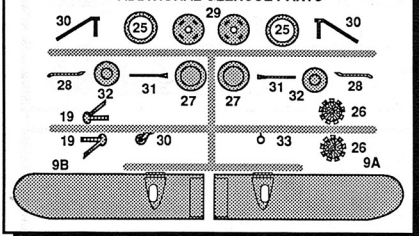

Cement Parts  
Coller  
Kleben  
Pegar  
Incollare  
Colar  
Kleben



Do Not Cement Parts  
Ne Pas Coller  
Nicht Kleben  
No Pegar  
Non Incollare  
Não Colar  
Niet Kleben



Cut Away  
Couper  
Scheiden  
Cortar  
Tagliare  
Cortar  
Snijden



Optional Parts  
Choix  
Auswahlmöglichkeit  
Elección  
Scelta  
Opcao  
Keuze



Repeat Operation  
Répéter l'opération  
Vorgang Wiederholen  
Repètir la operación  
Repètere  
Repètir a Opraço  
Herhalen

GLENCOE



MODELS

Box 846, Northboro, MA 01532

4 ?

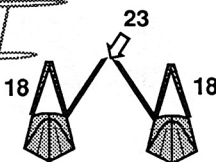
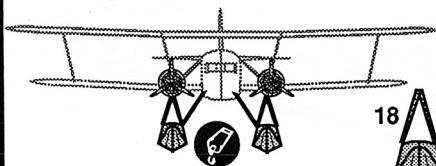
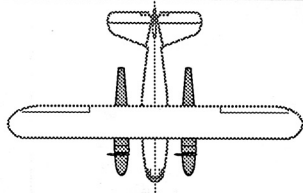
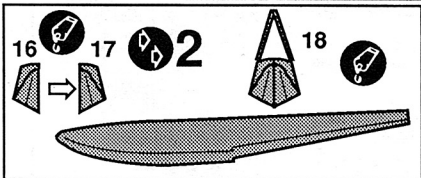

2

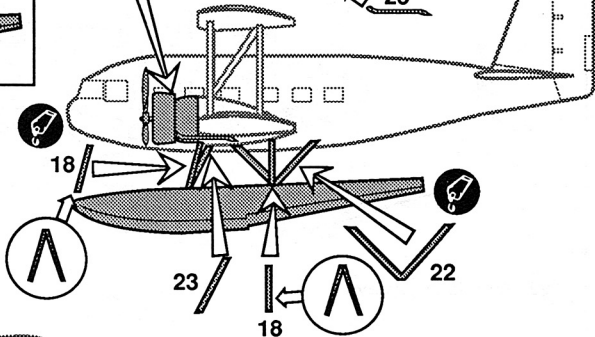
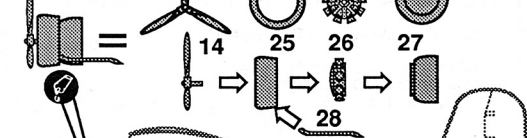

**COLLECTOR'S NOTE**

When this model was released by ITC in 1954, it include parts to build only the Byrd Expedition seaplane. When the molds were rediscovered in 1988, they were found to include wheels.

Although new wheels have been made for this kit, the original ITC wheels have been included as well. Puzzle: How were the ITC wheels intended to fit?

4 ?

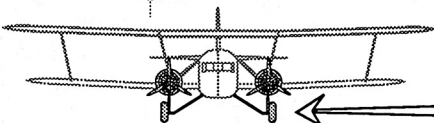
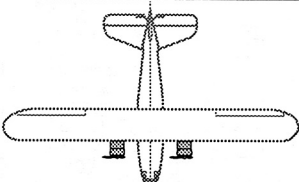
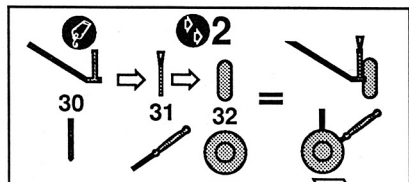

2

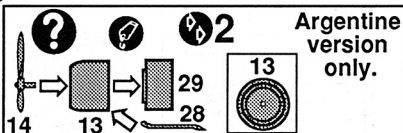
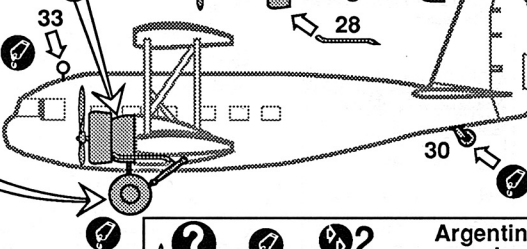
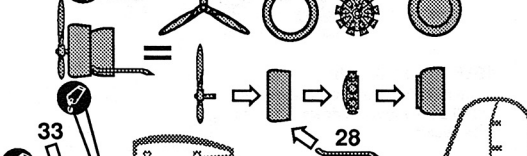

Argentine version only.

# Curtiss Condor Decal and Painting Guide

06001

(11) NUMBERS INDICATE DECAL PLACEMENT (★) SYMBOLS INDICATE COLORS

## 1933 Byrd Antarctic Expedition

(Note modified window arrangement. Fill windows 2 and 4 on both sides, and window 5 on left side.)

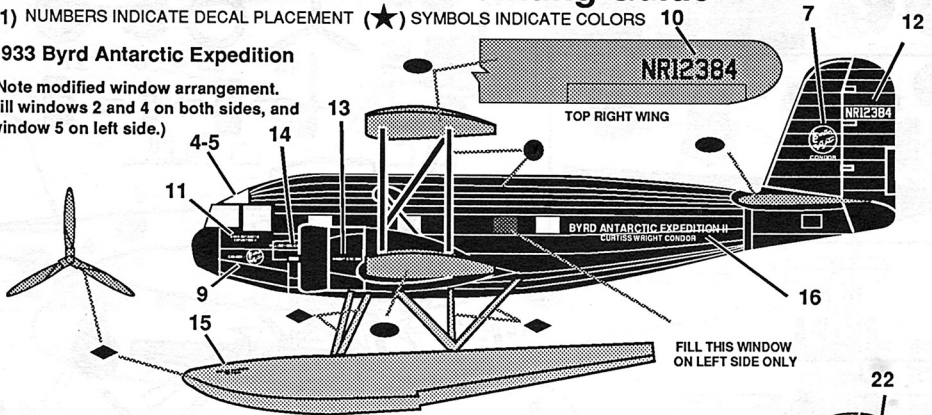

## 1933 American Airways

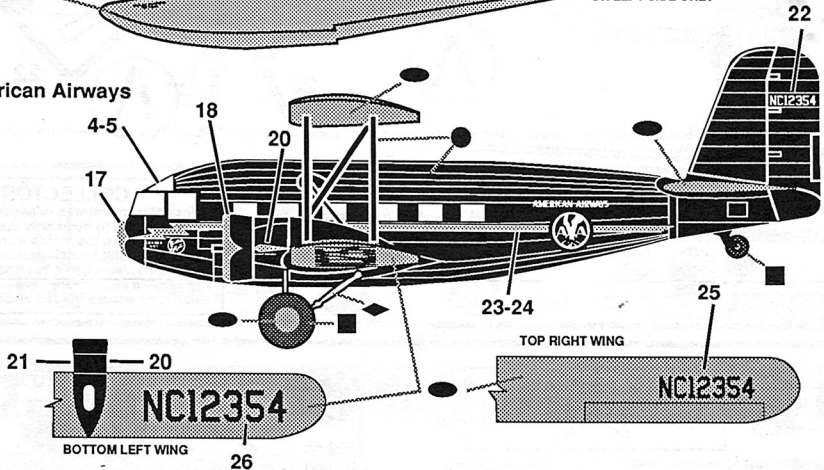

## 1938 Argentine Navy

(Note modified window arrangement. Fill all passenger windows. Replace with decals.)

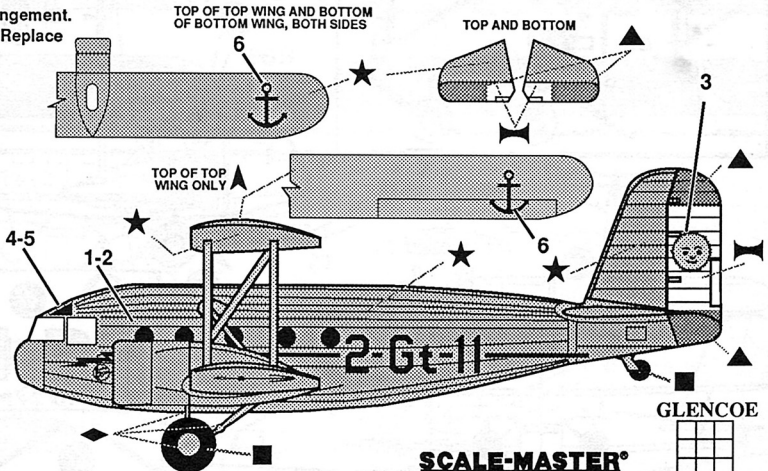

### COLOR SYMBOL IDENTIFICATION

- FLAT BLACK
- DARK BLUE FS 25056
- ORANGE (TESTOR 1127)
- ▲ LIGHT BLUE FS 25240
- ★ LIGHT GRAY FS 16515
- ◆ SILVER
- ◻ WHITE
- ▲ YELLOW FS 13655

# History of Swissair and International Air Freight Curtiss Condors

## Swissair Curtiss Condor

Apart from the ten improved AT-32 models of Condors produced by Curtiss for American Airways, the only other civil AT-32 (c/n 53) was for Swissair (CH-170). This was delivered in late March of 1934. It went into service on the Zurich-Berlin route and came to a tragic ending when it crashed killing all on board. It was the first airliner in Europe to have a stewardess.

For many years the markings for the Swissair were thought to have a red fuselage with silver wings and a blue circle containing the Swiss *CH*. However, after further investigation, it turns out to have been a blue fuselage rather than red and with a red circle containing the *CH*.



## International Air Freight, Ltd.

In 1937, four ex-Eastern Air Transport Curtiss T-32 Condors were purchased by a British company, International Air Freight Ltd. out of Croydon (c/ns 28, 29, 30, and 36). There was not a great demand for this kind of business and I. A. F. went into liquidation in September of 1938.

The four aircraft were taken over by the Air Ministry to be used as navigational trainers but were never used and later scrapped.



## Are there any Curtiss Condors still in existence?

There are no existing Curtiss Condors. However, there is a group of people in the United States that has been rescuing pieces of Condors from all over North America and plan to rebuild a flyable example. That will be very exciting.

## Bibliography

Air Enthusiast, *The Uncompetitive Condor* by H. A. Taylor, Volume 6, 1978, pp. 94 - 106.  
Flying Review, *The Saga of the Condor* by William R. Matthews, May 1967, pp. 579 - 582.  
A.A.H.S Journal, *Curtiss Condor II*, by William Matthews, Spring 1967, pp. 3 - 27.

I would like to thank Richard Ward of Model Decals and William Matthews for updating this information, particularly the Swissair colors. The photos are provided by William Matthews and are reproduced here with his permission. They are the sole property of William Matthews and cannot be reproduced without his permission.

# Curtiss Condor Decal and Painting Guide

(11) NUMBERS INDICATE DECAL PLACEMENT (◆) SYMBOLS INDICATE COLORS

## 1934 Swissair

NOTE: Some sources indicate the fuselage of the Swissair Condor was red, some say it was blue. If you wish to paint your model blue, use decals 6 and 7 on the tail. If you paint it red, use decals 4 and 5.

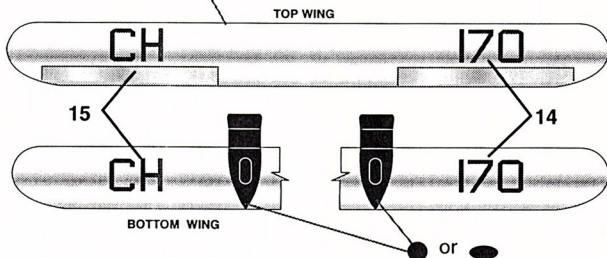
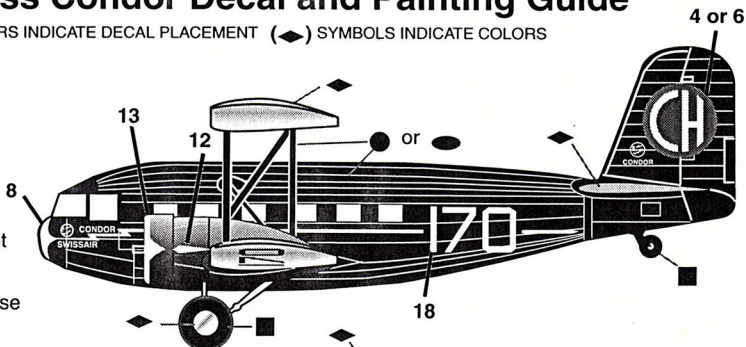

## 1937/8 INTERNATIONAL AIRFREIGHT

(Note: Fill all passenger windows.)

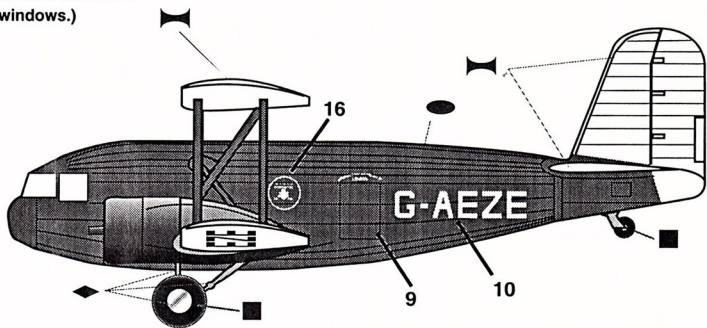

### COLOR SYMBOL IDENTIFICATION

- FLAT BLACK
- DARK BLUE FS 25056
- RED (TESTOR 1103)
- ◆ SILVER
- ◐ WHITE

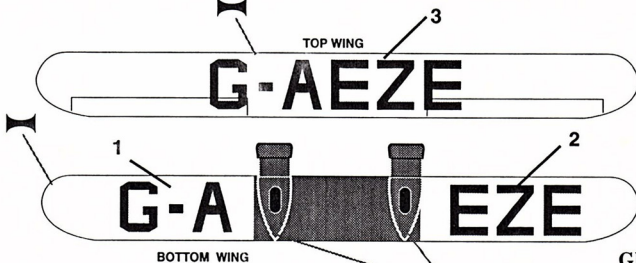

©1999Glencoe Models. All rights reserved.

06001-2

GLENCOE  
MODELS