

1:35 SCALE

## T-55 model 1958 with BTU-55

芬兰BTU-55带推土铲

颜色指示  
COLOR

1 - 白色 White  
8 - 银色 Silver  
28 - 黑铁色 Steel

33 - 消光黑 Flat black  
38 - 橄榄色 Olive drab  
43 - 木棕色 Wood brown



cyanoacrylate glue  
使用强力胶



weight  
配重



make hole  
钻孔



cut / remove  
切除



bend  
弯曲



file / sand  
锉平



option  
选择



no cement  
不涂胶水



decal  
贴纸

## 水贴纸的使用:

1. 从水贴纸上剪下印花;
2. 将印花放入温水中浸10秒, 然后放在干净布上。
3. 拿着印花纸板将印花移到模型上;
4. 手指蘸水将印花移到适当的位置;
5. 用软布轻压印花直至水干, 气泡消失。

## DECAL APPLICATION

1. Cut off decal from sheet.
2. Dip the decal in tepid water 40°C for about 10 sec. and place on a clean cloth.
3. Hold the backing sheet edge and slide decal onto the model.
4. Move decal into position by wetting decal with finger.
5. Press decal gently down with a soft cloth until excess water and air bubbles are gone.

# 部品图 Parts

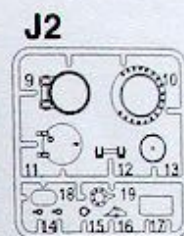
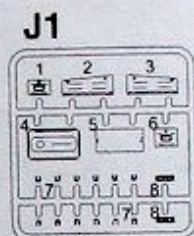
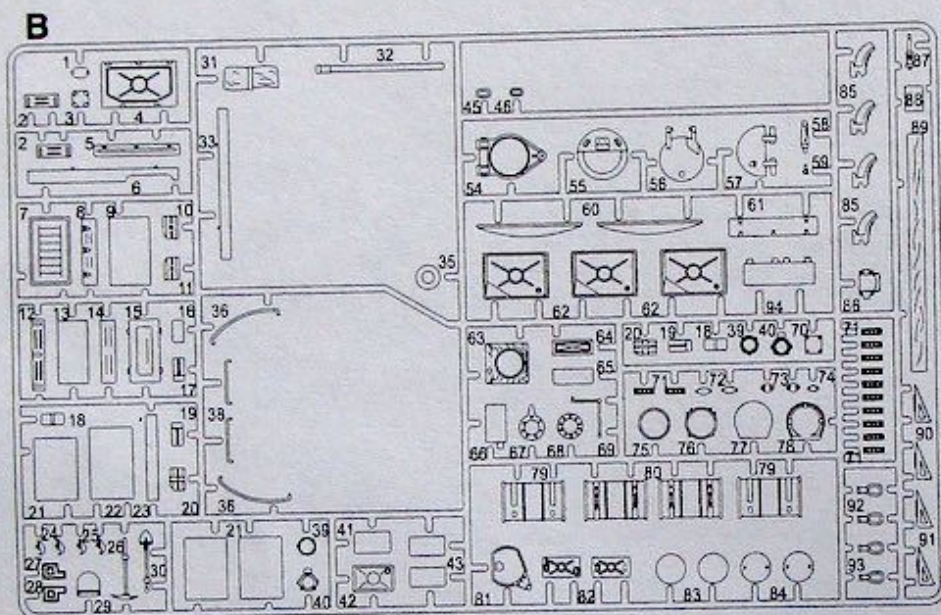
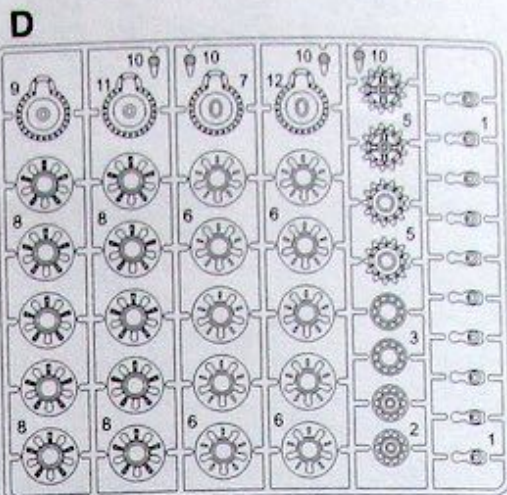
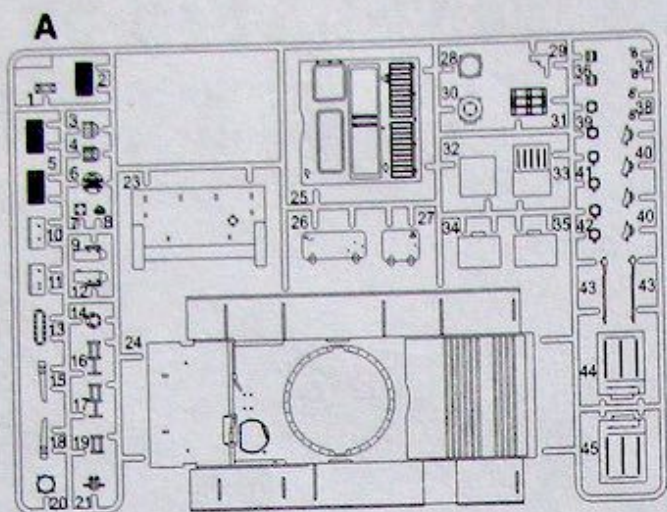

不用部品

Parts not used

- A2, A3, A4, A5, A8, A9, A10, A11, A12
- A14, A16, A19, A29, A34, A35, A43 \* 2
- B1, B4, B5, B6, B10, B11, B13, B14, B15, B16
- B17, B18, B19, B20, B22, B26, B27, B28, B29
- B30, B31, B32, B33, B39, B40, B58, B65, B66
- B67, B68, B72, B74, B75, B76, B77, B78, B86
- E5, E7, E8, E9, E10, E11, E12, E13, E14
- J8, J9, J10, J13

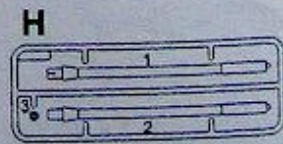
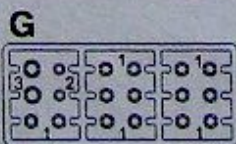
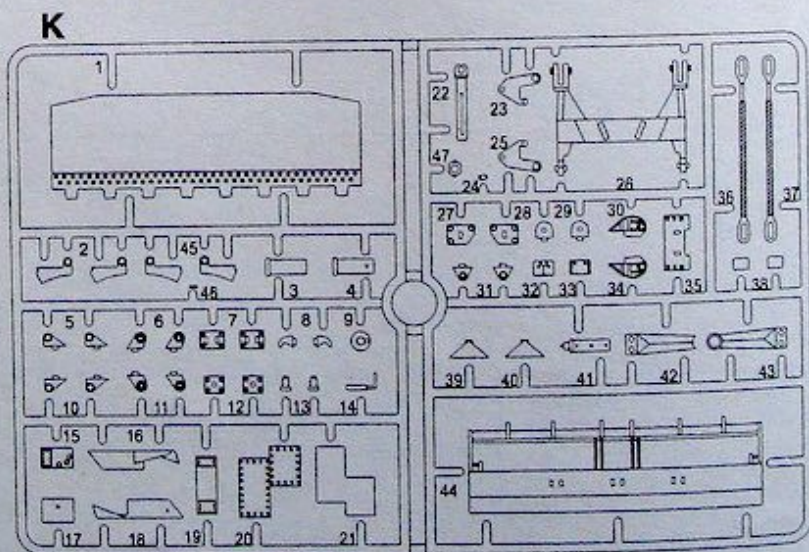
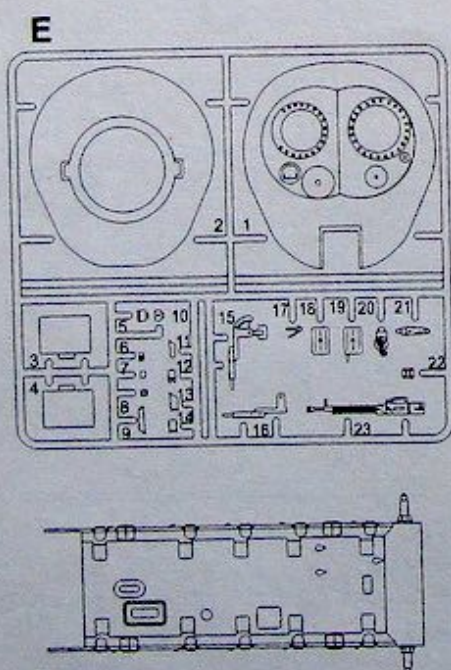

扇带 × 2  
Track × 2

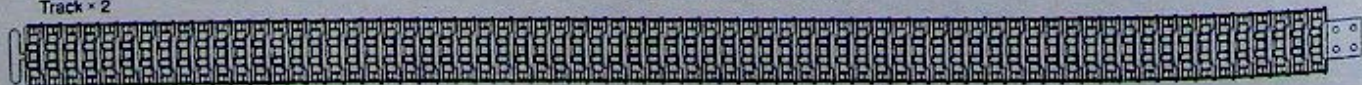

**1** 车轮组装  
Wheel assembly

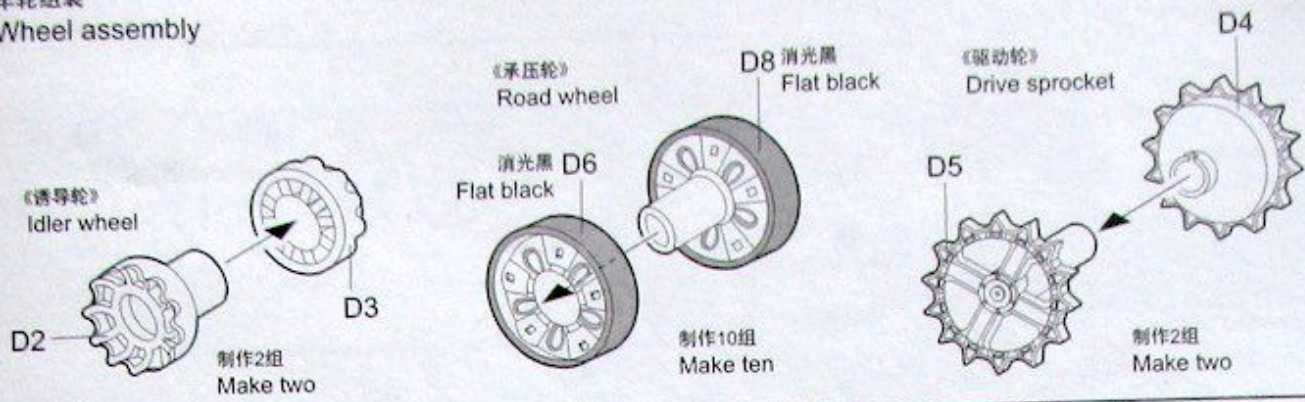

**2** 车底组装 I  
Lower hull assembly I

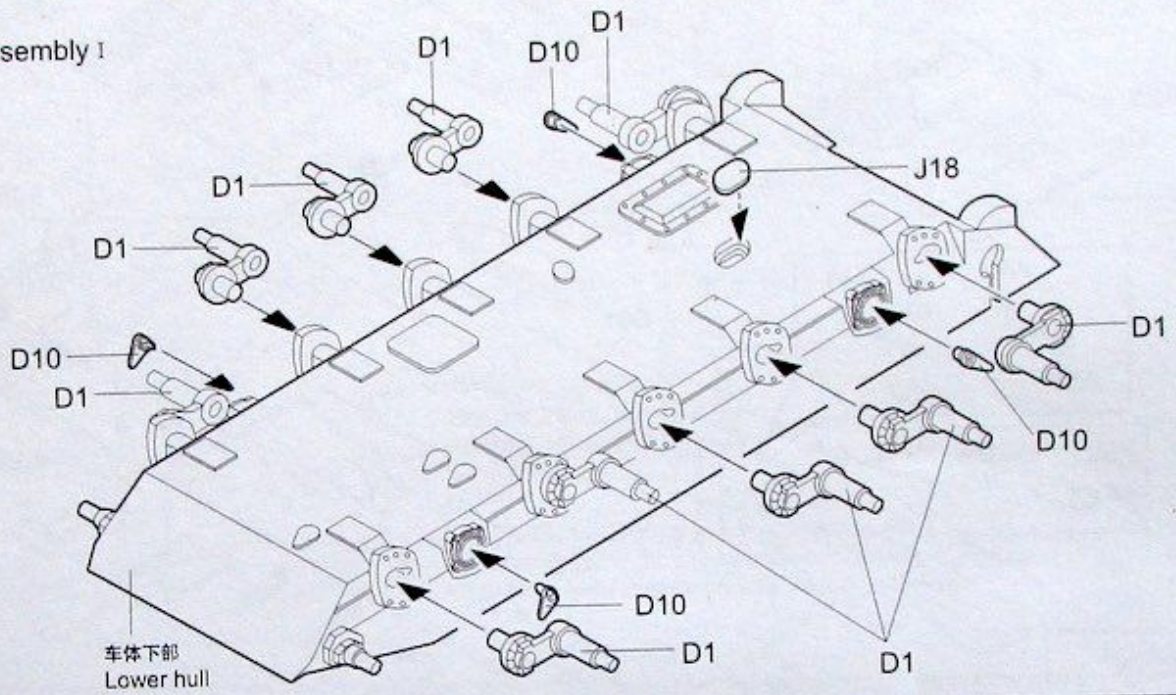

**3** 车轮安装  
Attaching wheels

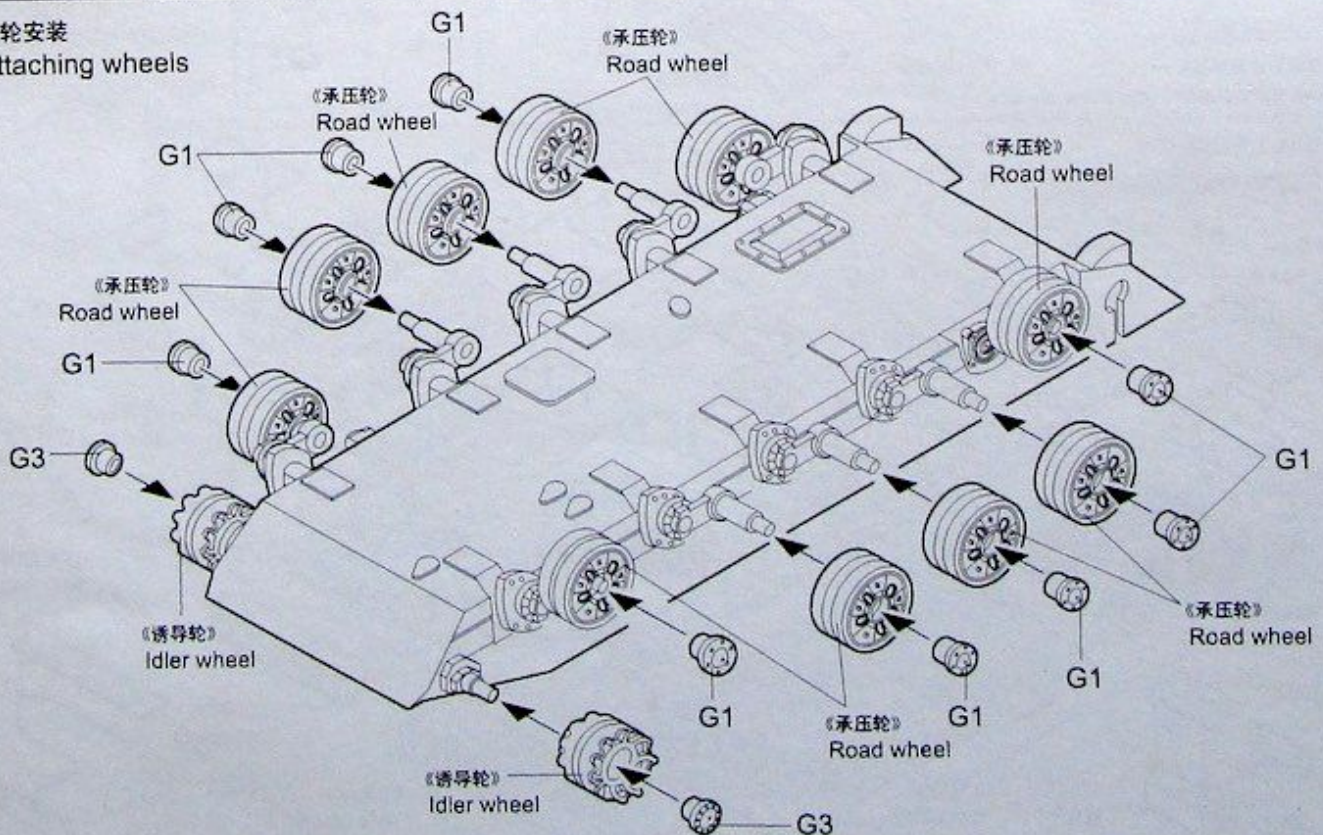

#### 4 车体上部组装 I Upper hull assembly I

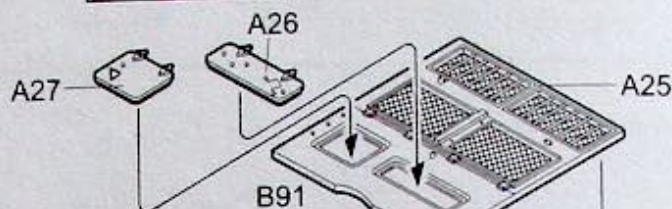
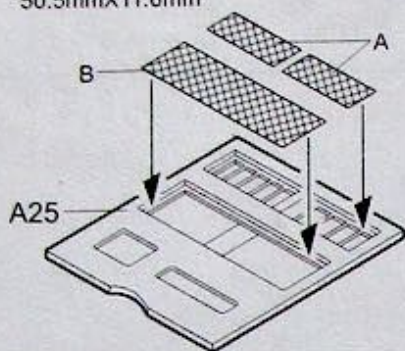
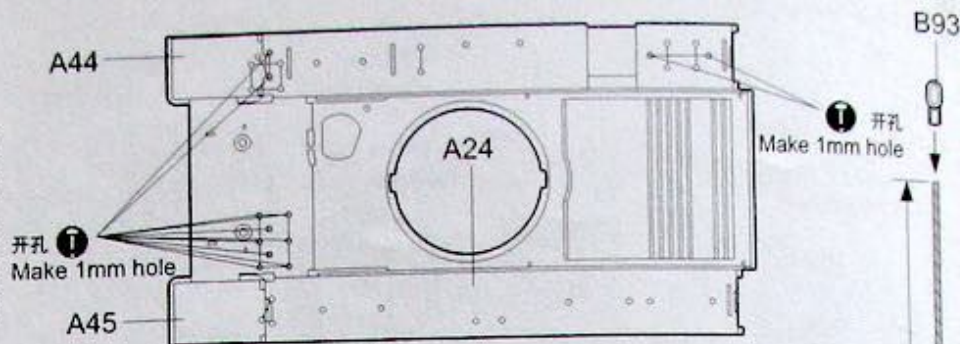

牵引绳  
Tow cable  
制作2套  
Make two

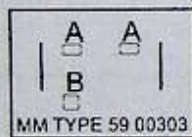
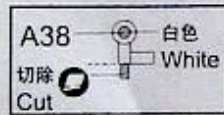
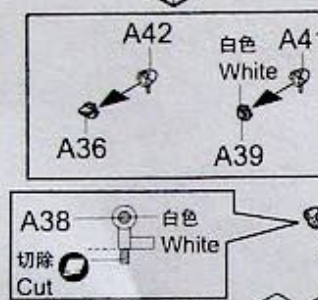

用小刀切下透明部品A  
Cut out transparent part A as shown

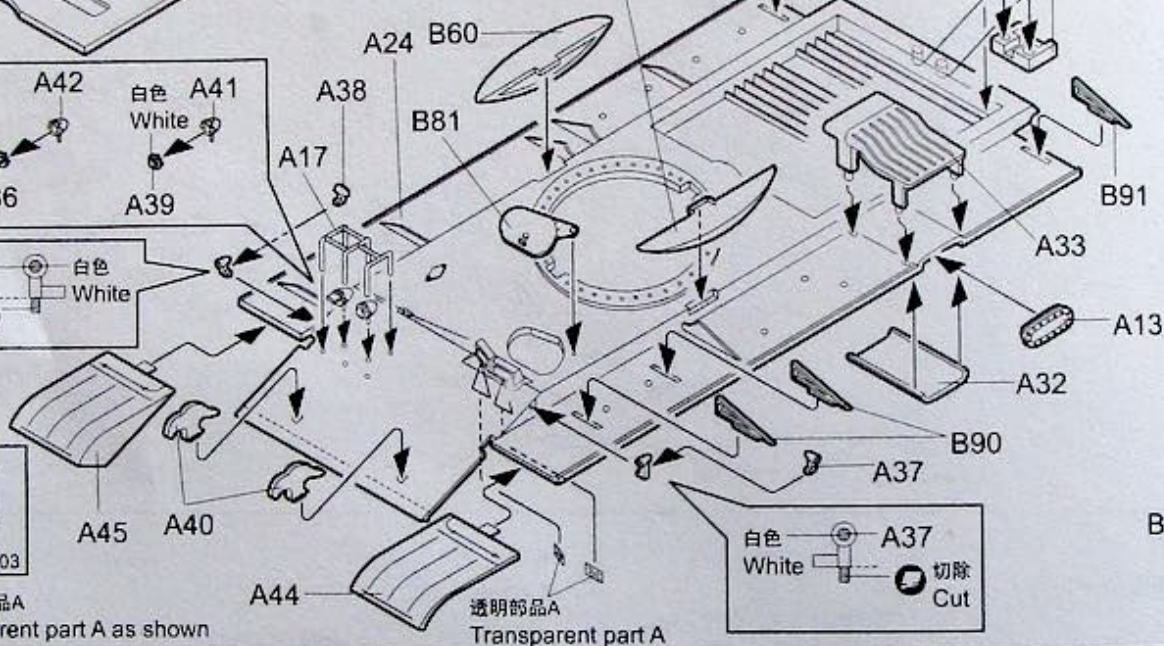

#### 5 车体上部组装 II Upper hull assembly II

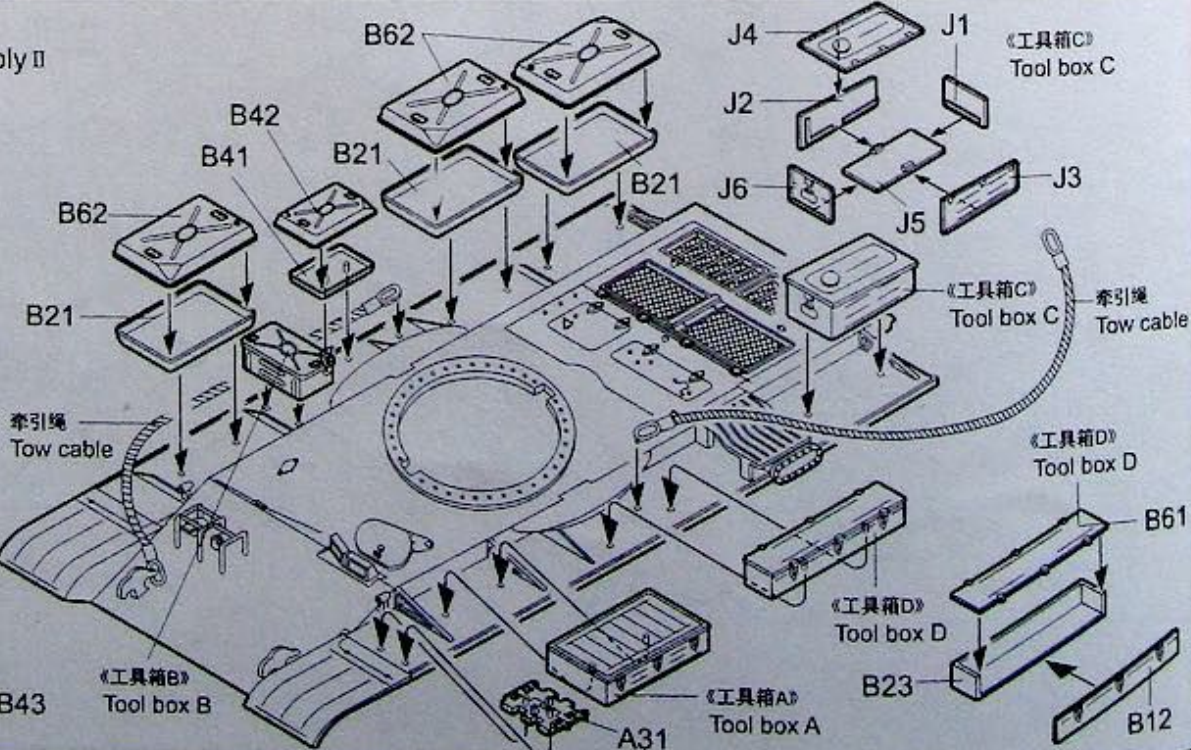
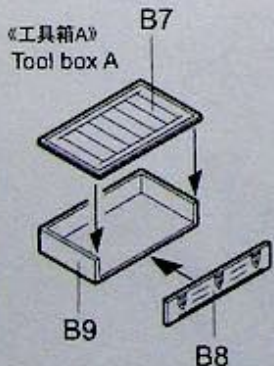

**6** 驱动轮安装  
Attaching drive sprocket

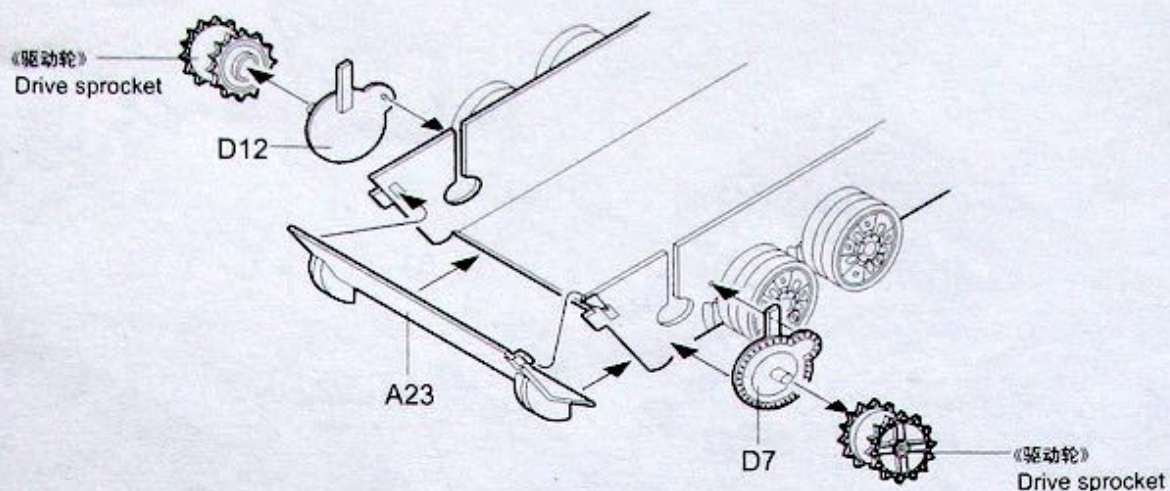

**7** 履带连接  
Track construction

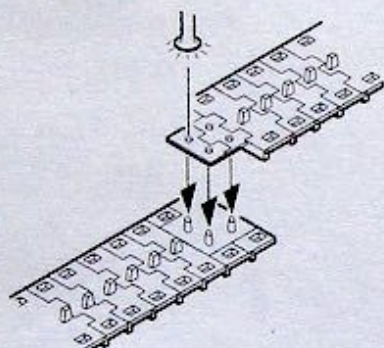

- ★根据实际要求选择履带尺寸。
- 用热铁钉软化接头，用手指压下接头。
- ★若履带断裂，用细丝线固定。

- ★Melt pin heads carefully with a heated nail etc.
- Immediately press pin heads with your finger.
- ★If track is broken strengthen with staples or thread.

**8** 车体上部安装  
Upper hull installation

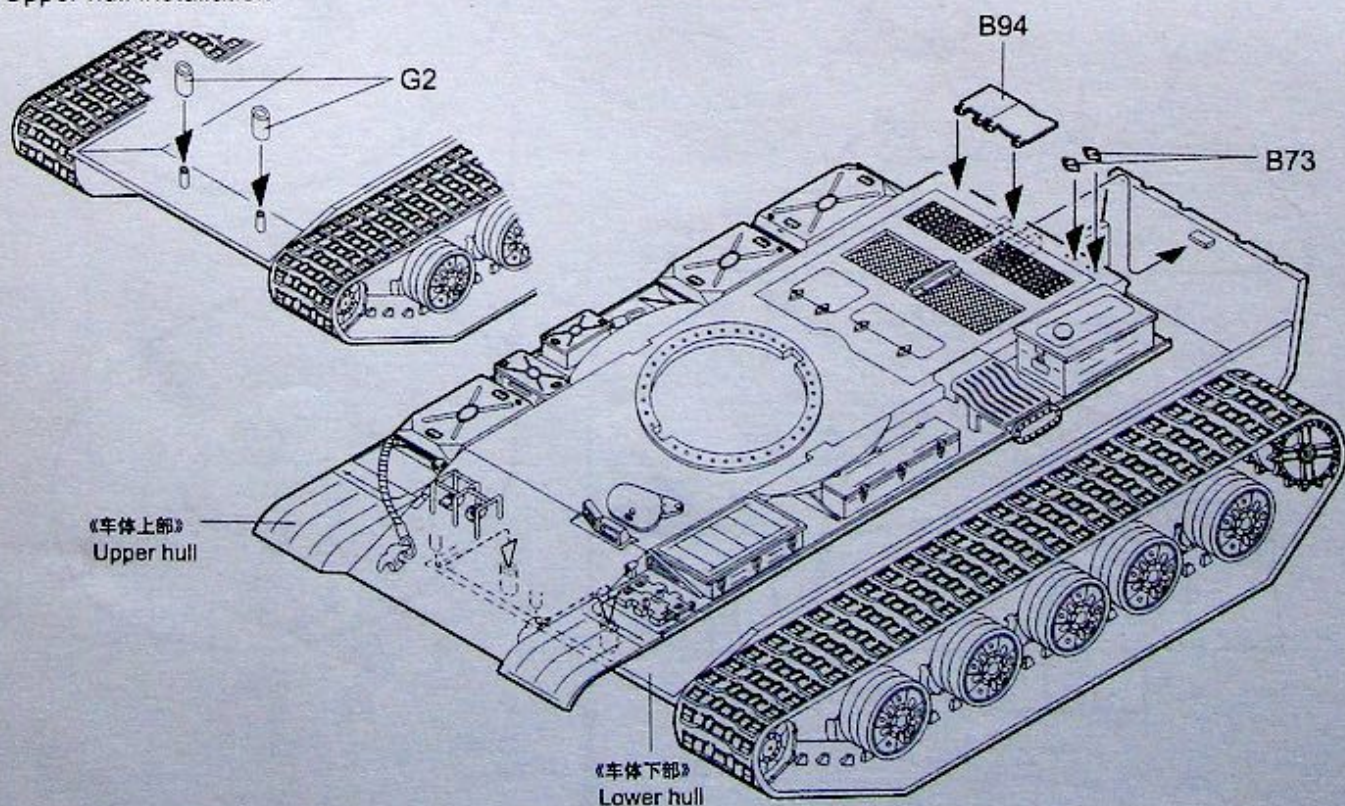

**9** 后挡板组装  
Rear panel assembly

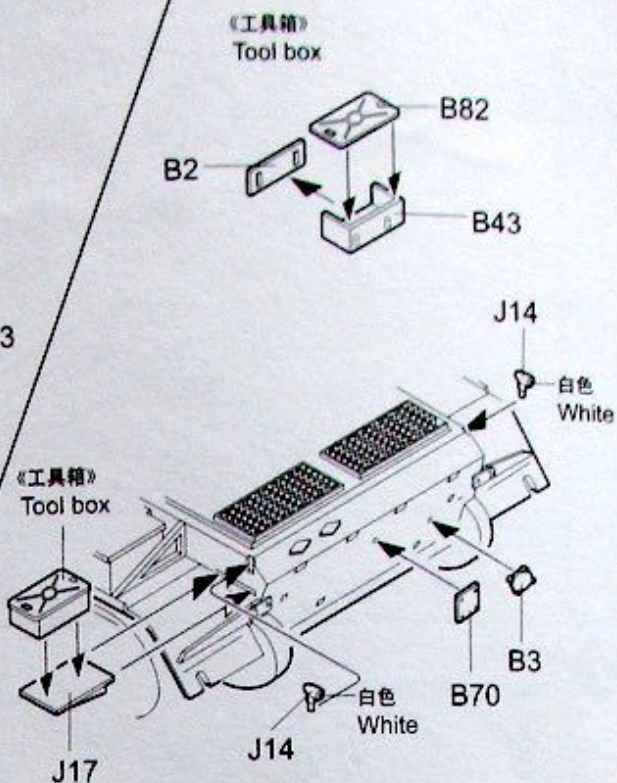
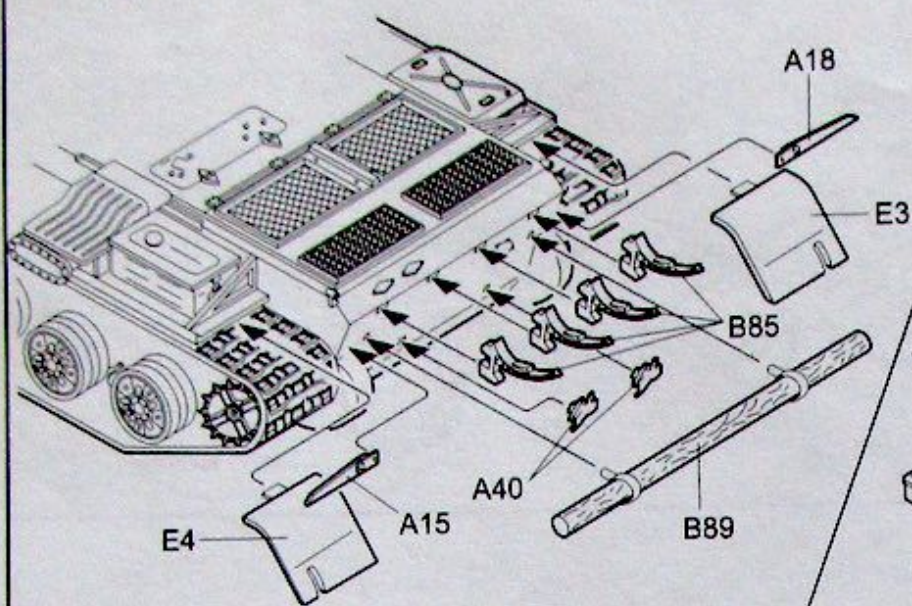

**10** 炮塔组装 I  
Turret assembly I

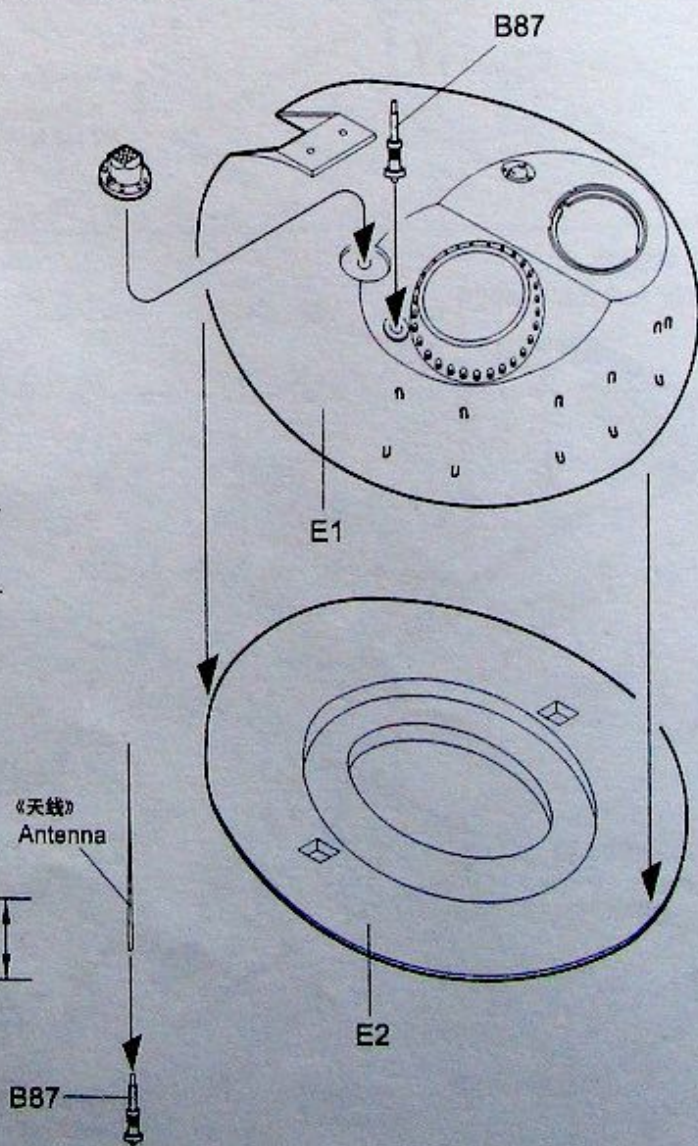
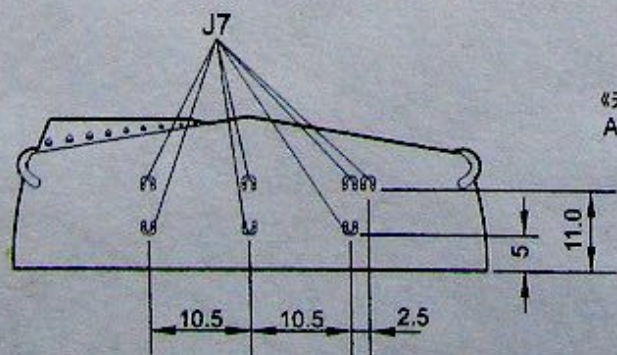
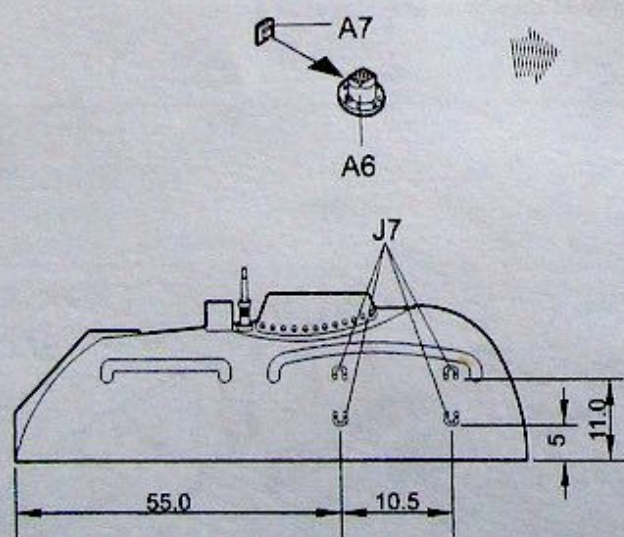

**11** 炮塔组装 II  
Turret assembly II

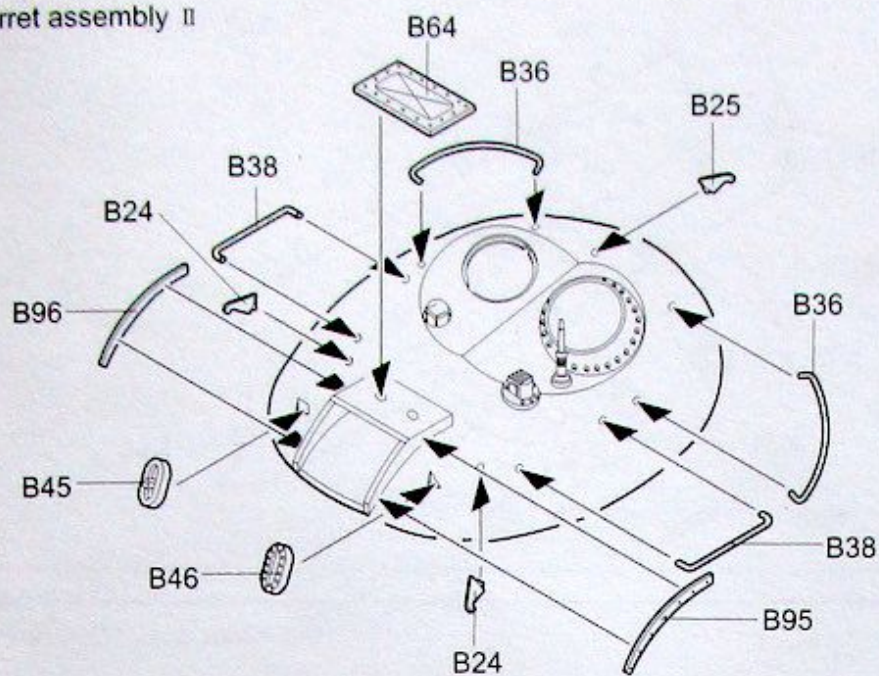

《天线制作》 How to make antenna

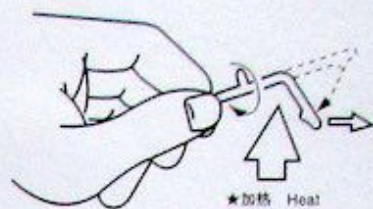

★加热浇口，拉线冷却，冷却后剪成所需长度。  
Heat sprue as shown, remove from flame and stretch allow to cool and cut to required length.

**12** 炮塔组装 III  
Turret assembly III

用小刀小心切下透明部品B  
Cut out transparent part B as shown

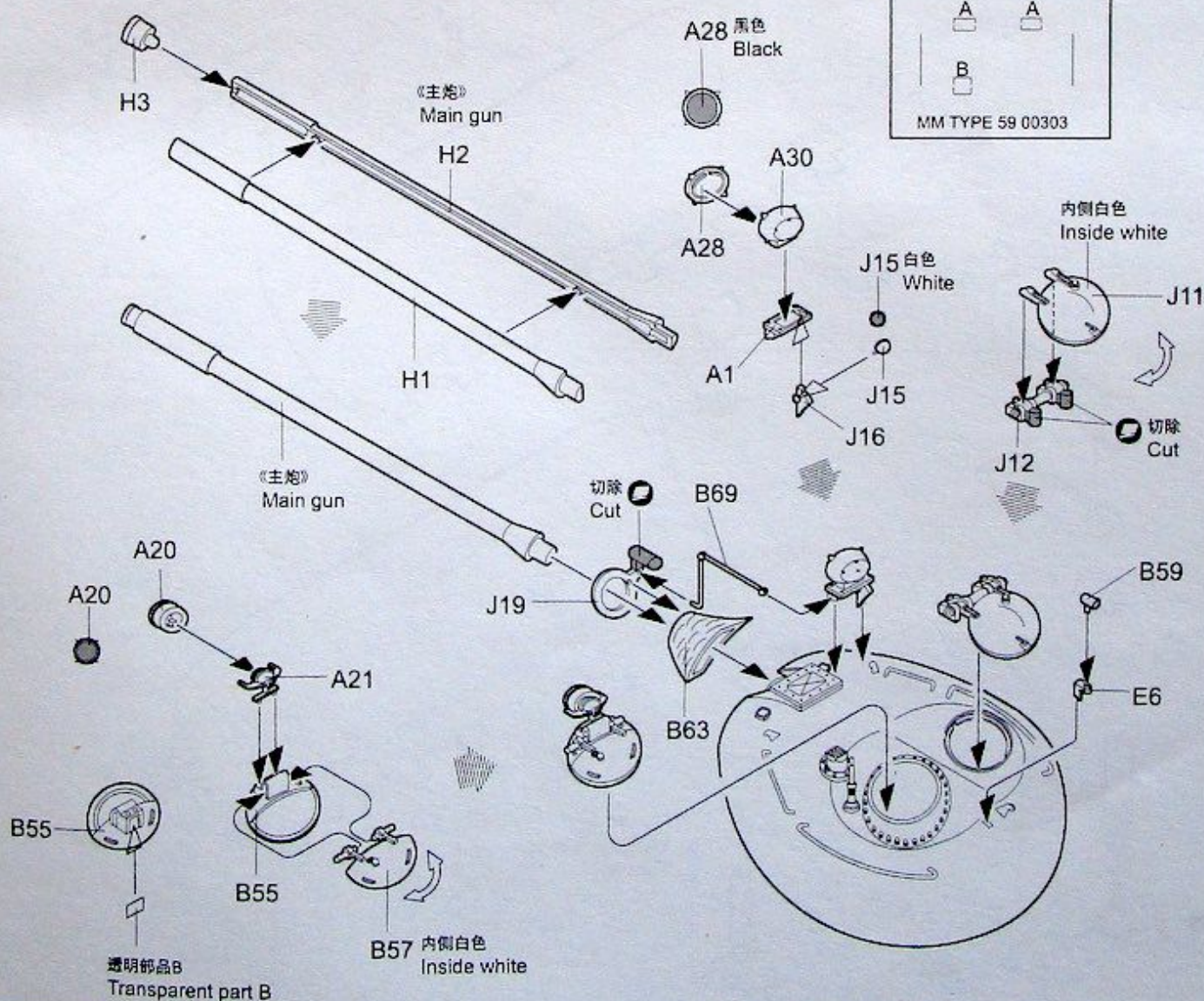
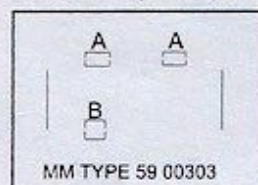

**13** 铲的组装 I  
Dozer blade assembly I

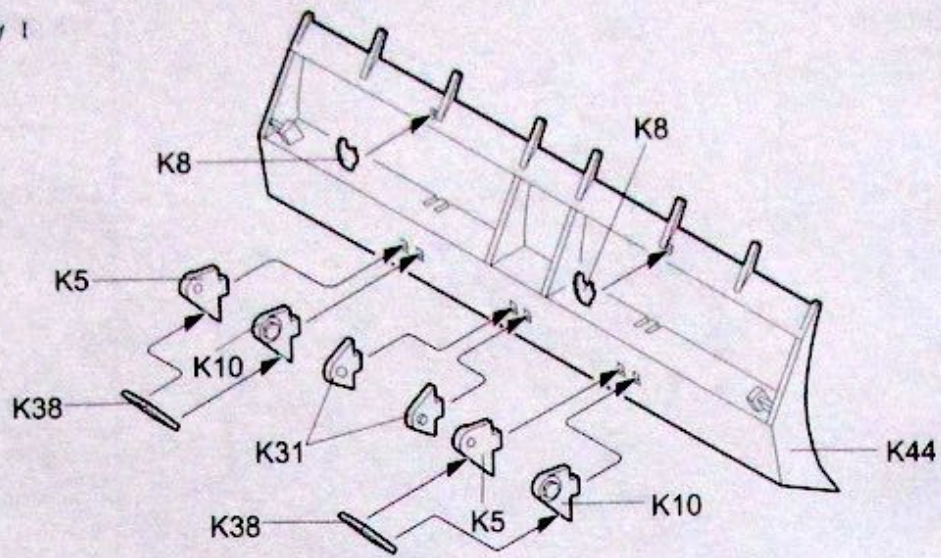

**14** 铲的组装 II  
Dozer blade assembly II

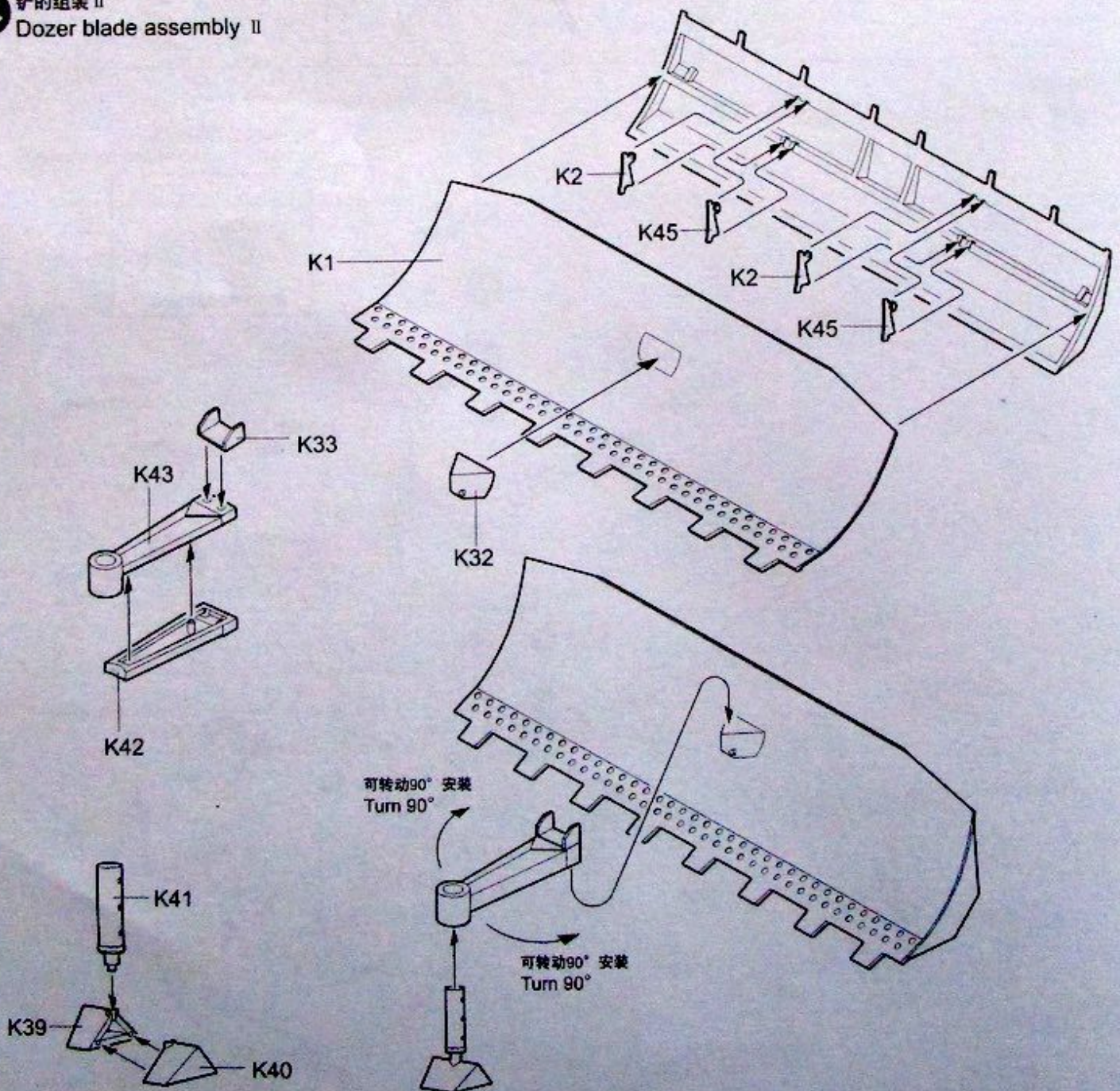



**15** 铲的组装 III  
Dozer blade assembly III

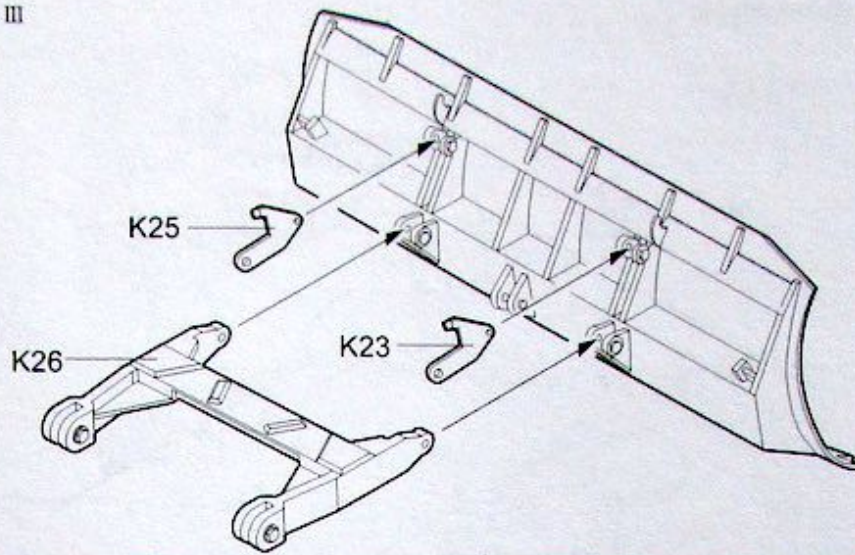

**16** 铲部件组装 I  
Dozer blade parts assembly I

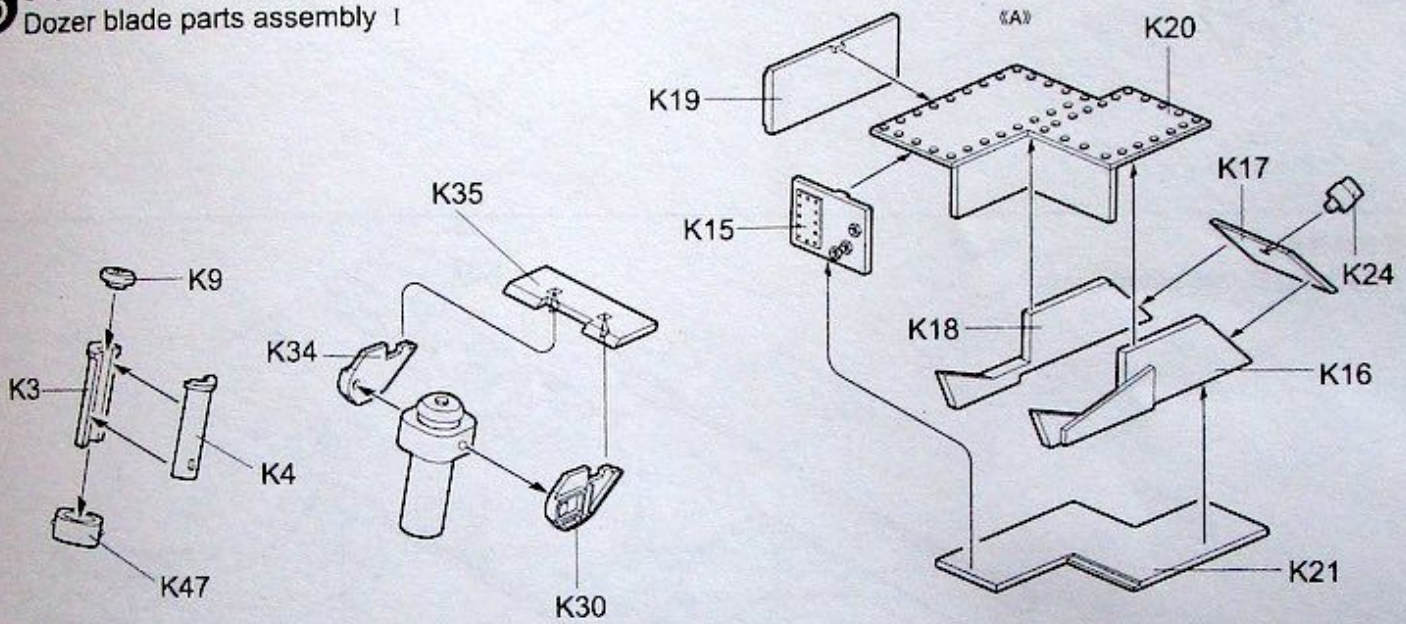

**17** 铲部件组装 II  
Dozer blade parts assembly II

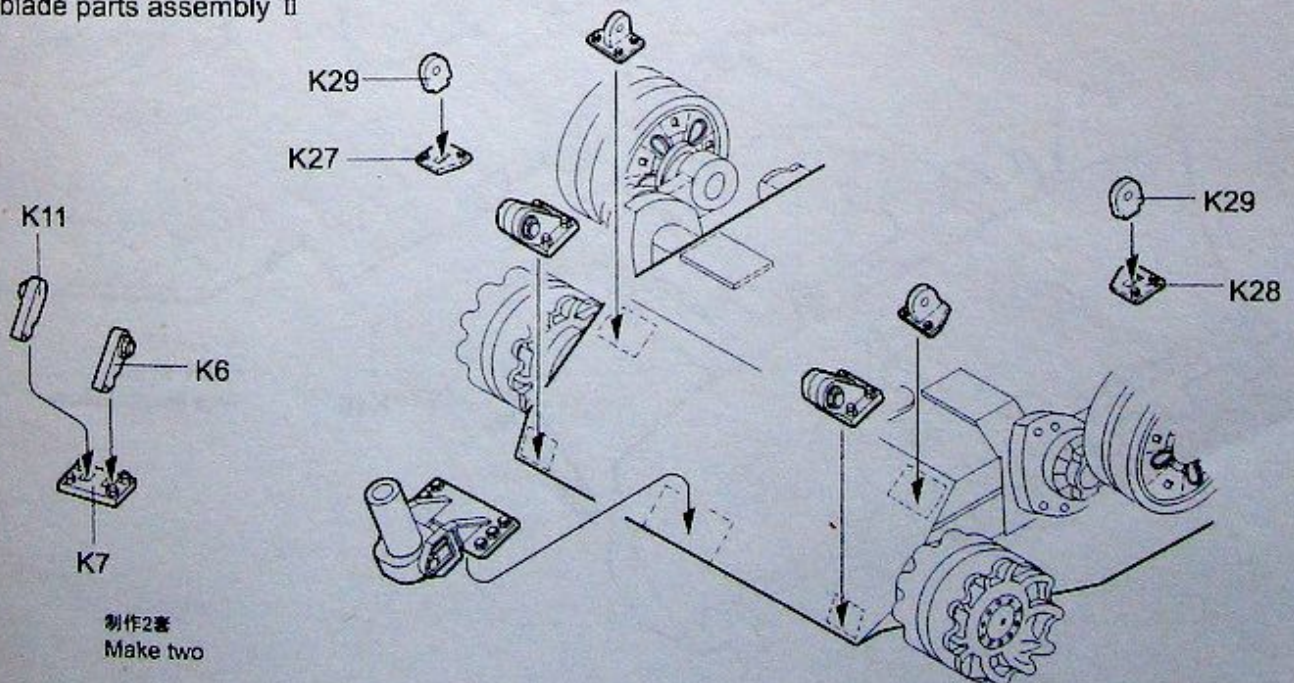

**18** 铲部件组装 III  
Dozer blade parts assembly III

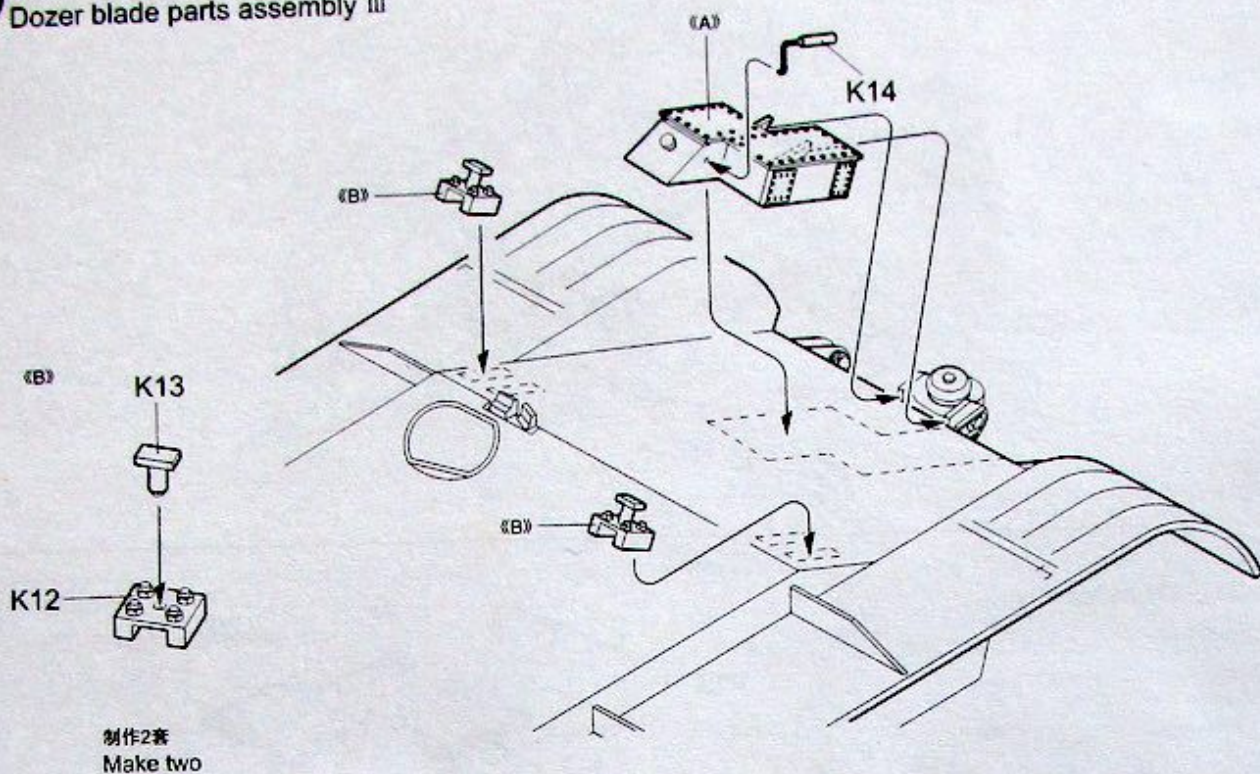

**19** 铲部件连接  
Attaching Dozer blade parts

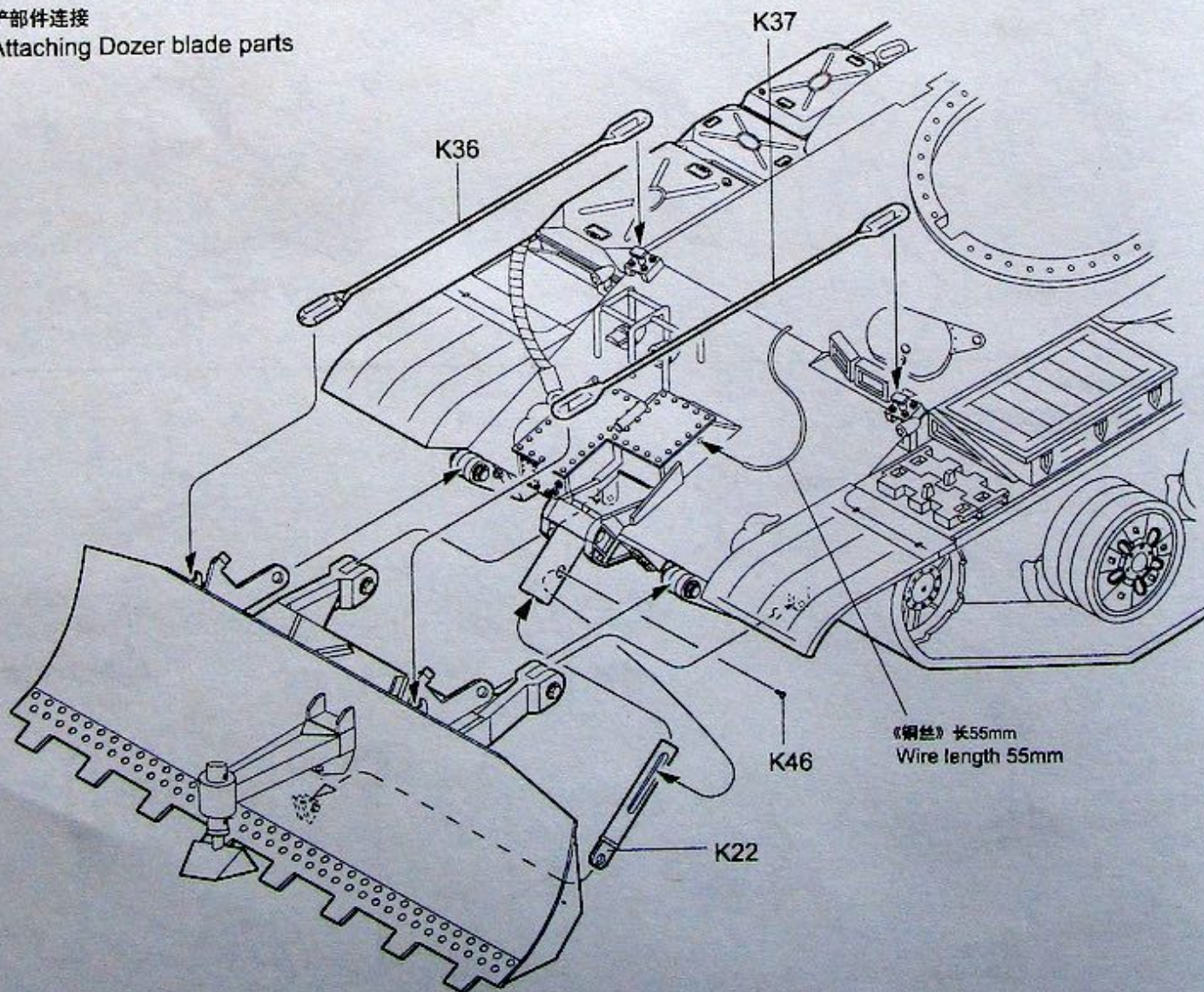

20 炮塔连接  
Attaching turret

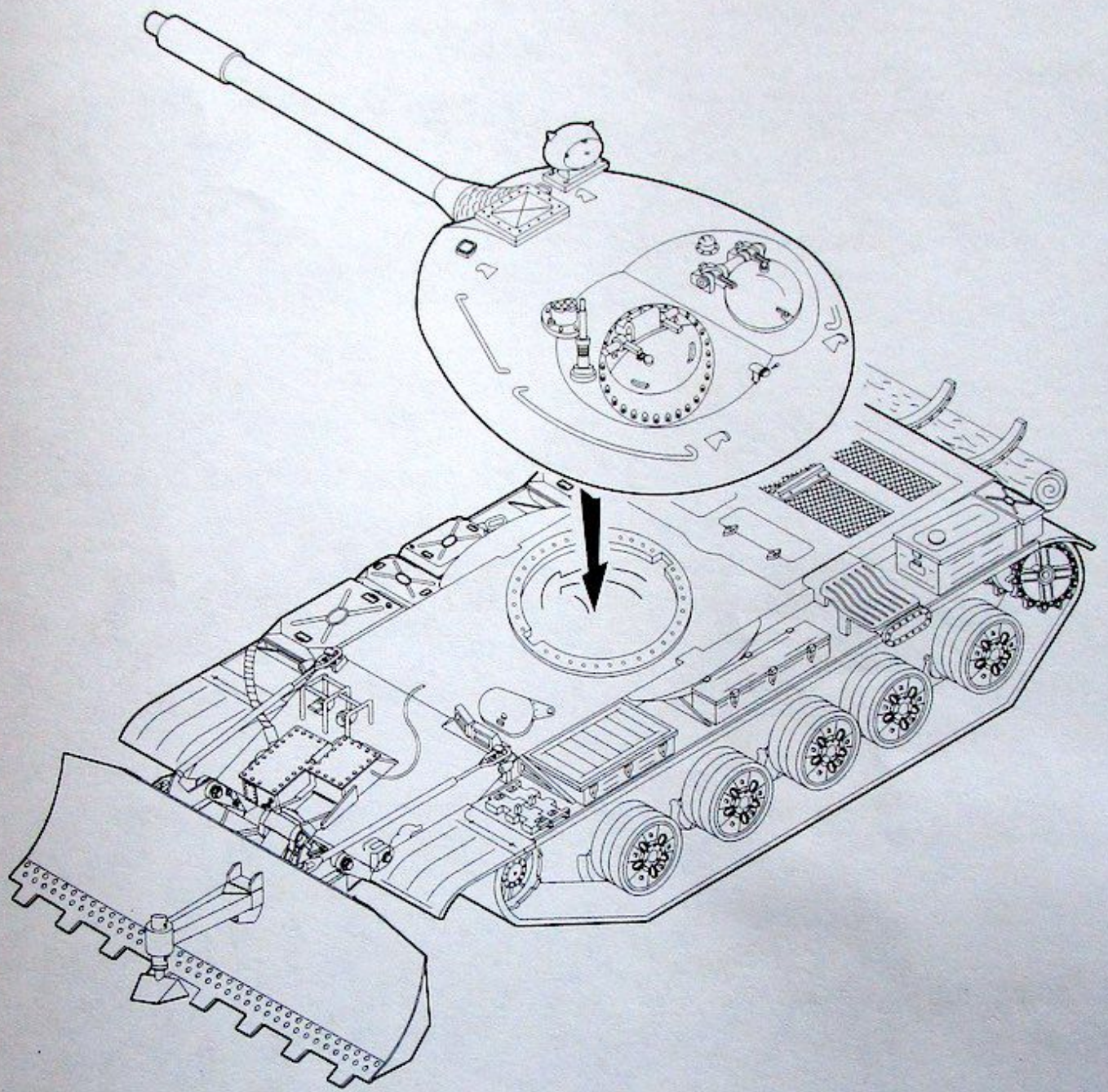

涂装同标贴指示  
Painting & Marking guide

郡仕色使用

Gunze Mr. color used

