

Supermarine Spitfire Mk.Vc

SW 72037 scale: 1/72



Sky-high piles of books have been written about one of the best British fighters - Supermarine Spitfire.

Following the Battle of Britain in 1940, the Royal Air Force had planned to replace its Spitfire Mk. I and II fighters with the Mk. III.

The development of this version took too long, and when Luftwaffe has introduced Messerschmitt Bf-109F, RAF had to make an interim version - Mk.V. Basically, the Mk. V consisted of a modified Mk. II airframe with a new Rolls-Royce Merlin 45 engine (followed by other Merlin versions).

The first Mk V was produced in January 1941, and tests showed it to be almost as good as the Mk III, but without the extra complexity in that version. In March 1941 it was decided to produce the Mk V instead of the Mk III. The type had already entered production by this stage, with No. 92 squadron being the first to receive it in February 1941. Production was initially divided between the Va with the eight machine gun "a" wing (94 built) and the Vb with the "b" wing of two 20mm cannon and four machine guns. In October 1941 the Mk Vc appeared. This used the universal "c" wing developed for the Mk III, which could carry either eight machine guns, four 20mm cannon or two cannon and four machine guns. The two cannon/ four machine gun combination was most common, as the four cannon version was significantly heavier, reducing performance.

The Mk V was the first Spitfire to be used in large numbers outside Britain - Malta, Africa, Australia, USSR. For some of these theatres of war, the RAF tropicalized (Trop) the Spitfire Mk. Vs by adding Vokes or Aboukir air filter. MK.V was also used by Eagle Squadrons in RAF.

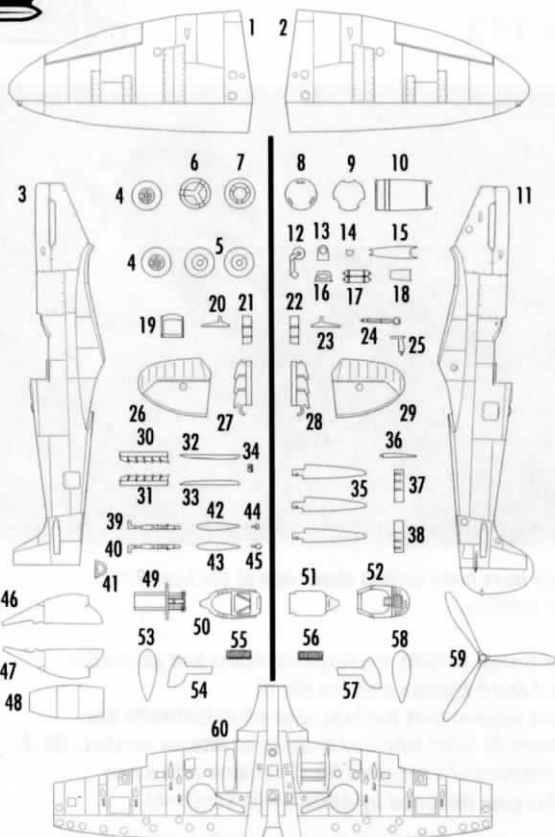

URETHAN

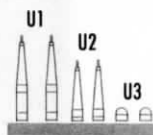

CLEAR

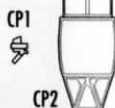

BARVA/COLOR

- (A) Černá/Black
- (B) Interierová zelená
Interior Green
- (C) Stříbrná/Silver
- (D) Hliník/Aluminium
- (E) Světle šedá/
Light Grey
- (F) Červená/Red
- (G) Žlutá/Yellow
- (H) Zelená/Green
- (I) Černošedá/
Tyre Black
- (J) Špinavý hliník/
Dirty Aluminium
- (K) Chromová/
Chrome
- (L) Hnědá/Brown
- (M) Kovová/Gun metal
- (N) Dřevo/Wood
- (O) Rezavá/Rust

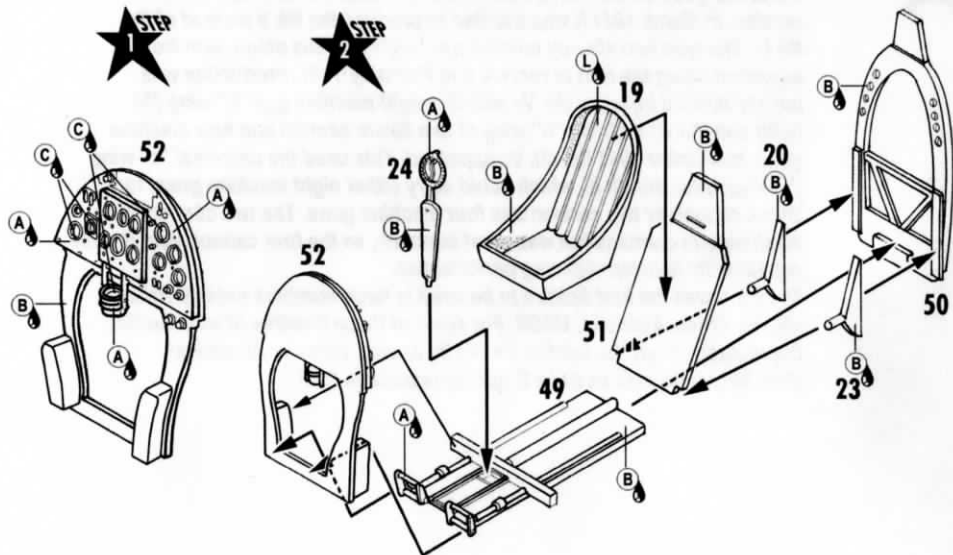

STEP 3 ?

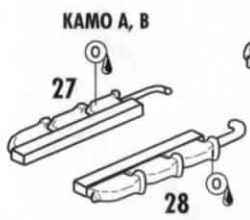

REMOVE

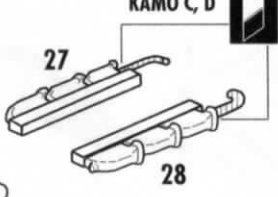

STEP 4

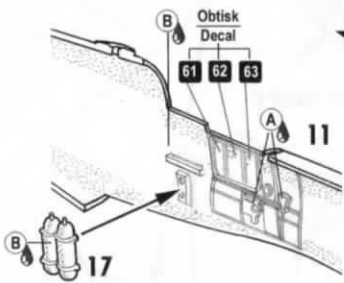

STEP 5

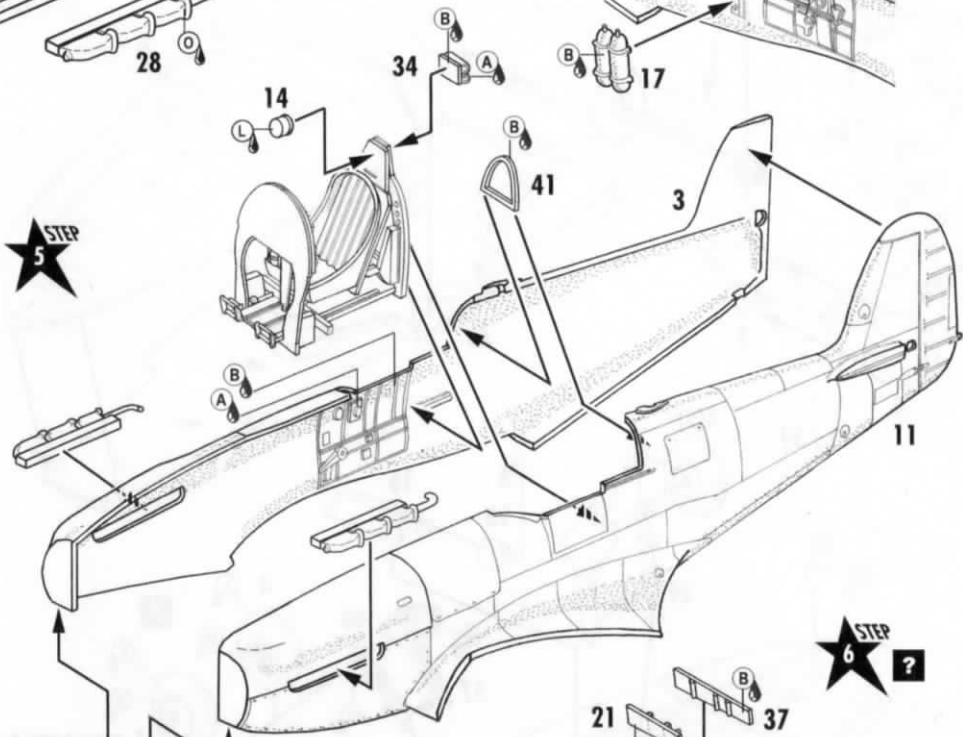

STEP 6 ?

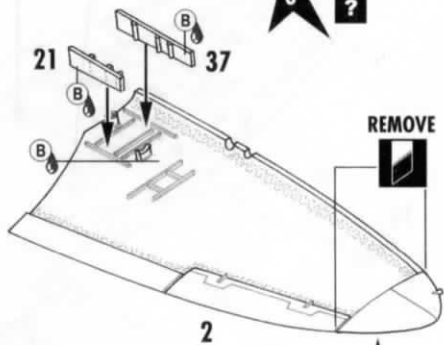

REMOVE

REMOVE

ONLY KAMO D

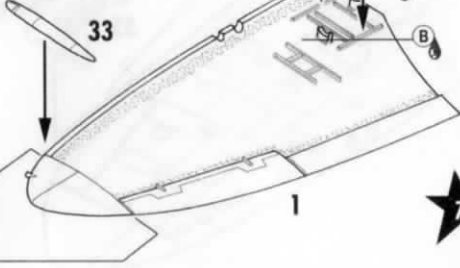

ONLY KAMO D

STEP 7 ?

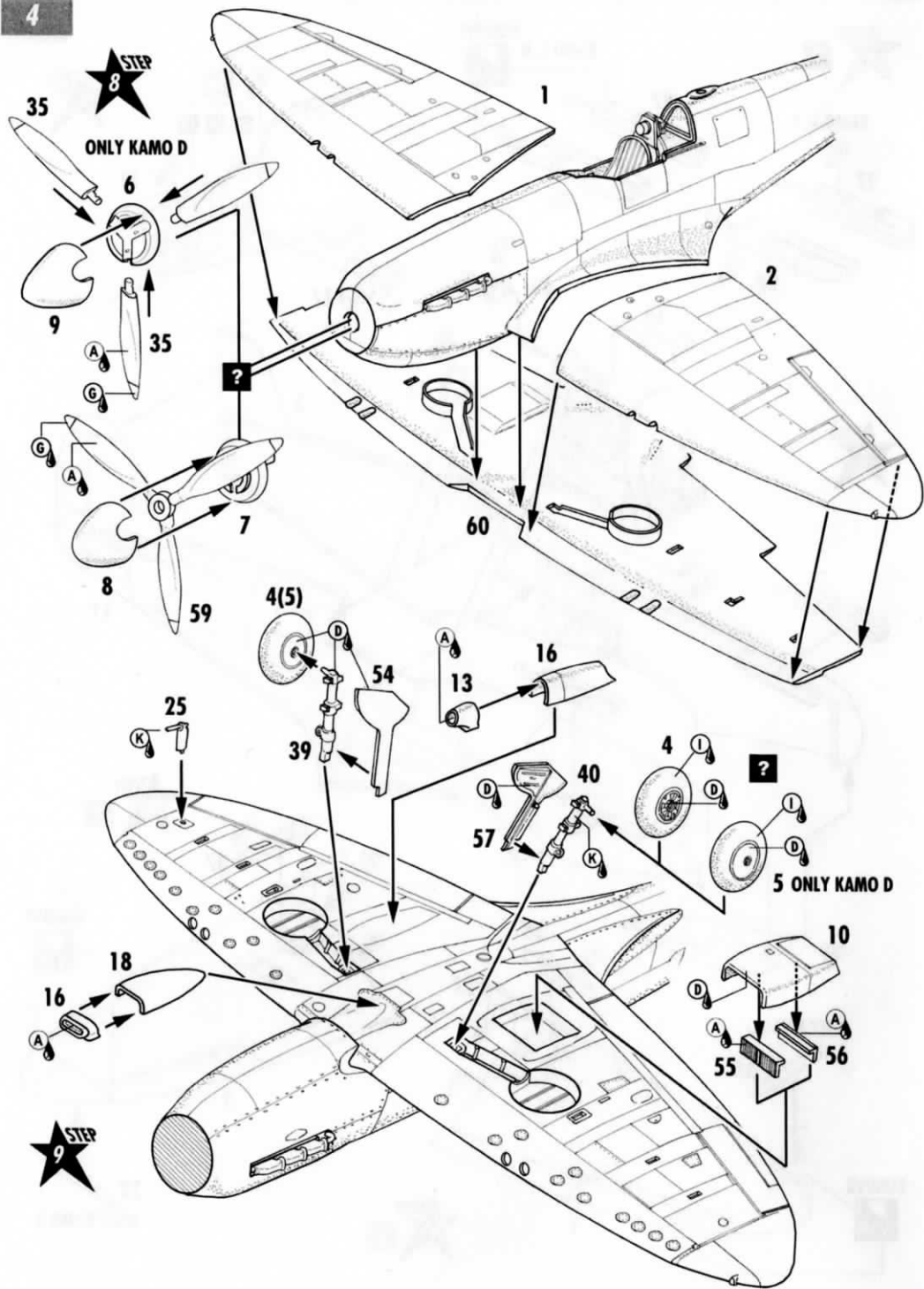

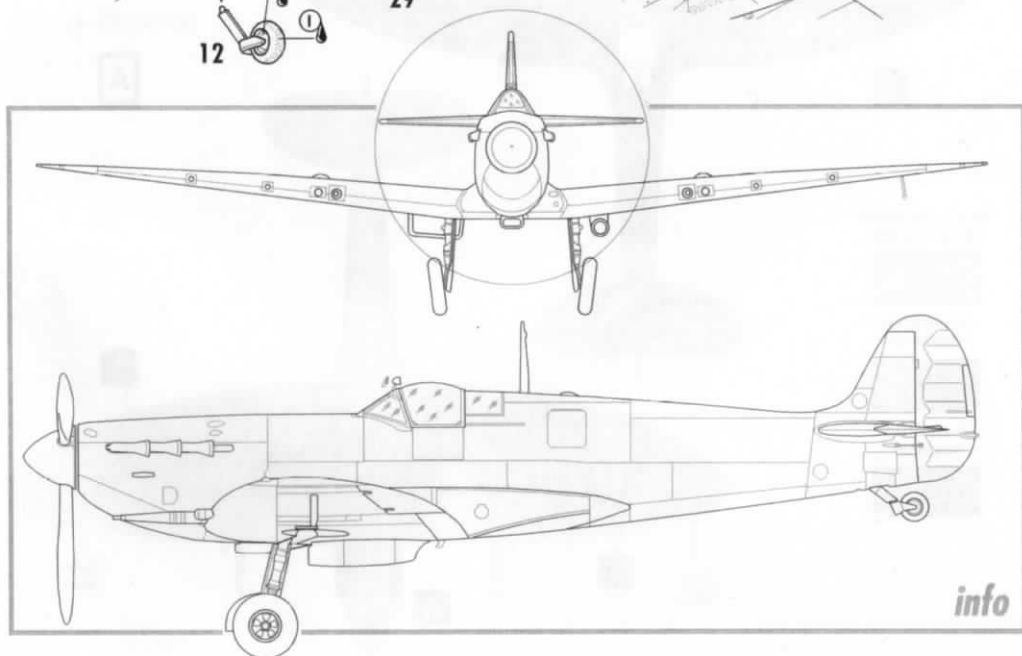
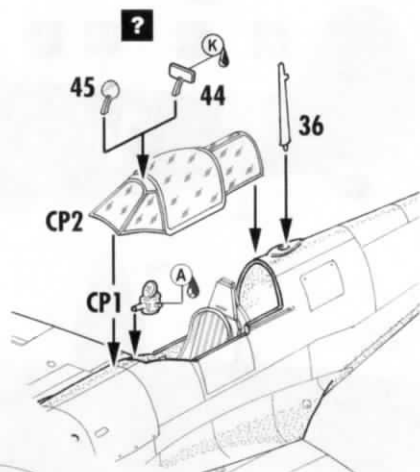
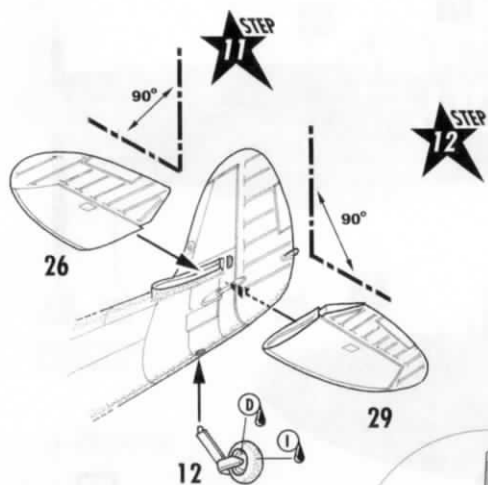
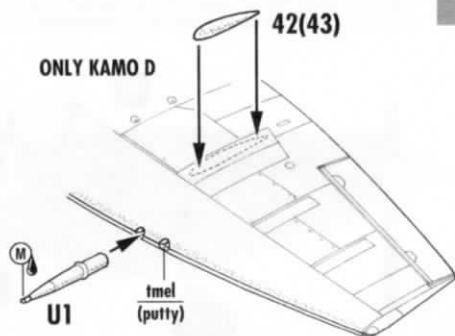
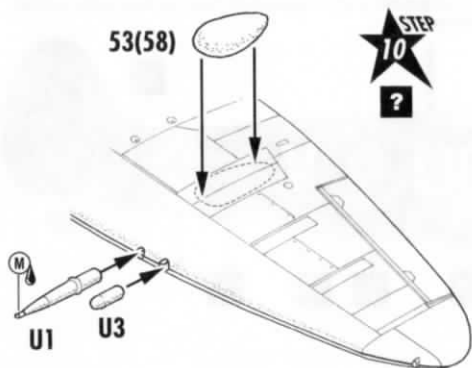

AR548, DU-V, Sgt.M.Liškutín, 312 Sqn. RAF, Churchstanton, Prosinec 1942. Během své operační činnosti dosáhl 2 vzdušná vítězství. 19.8.1942 poškodil Fw190A a sestřelil Do 217 od I/KG2. Liškutín se strojem AR548 těžce havaroval 6.1.1943, zázrakem zůstal nezraněn. AR548, DUV, Sgt.M.Liškutín, 312 Sqn. RAF, Churchstanton, December 1942.

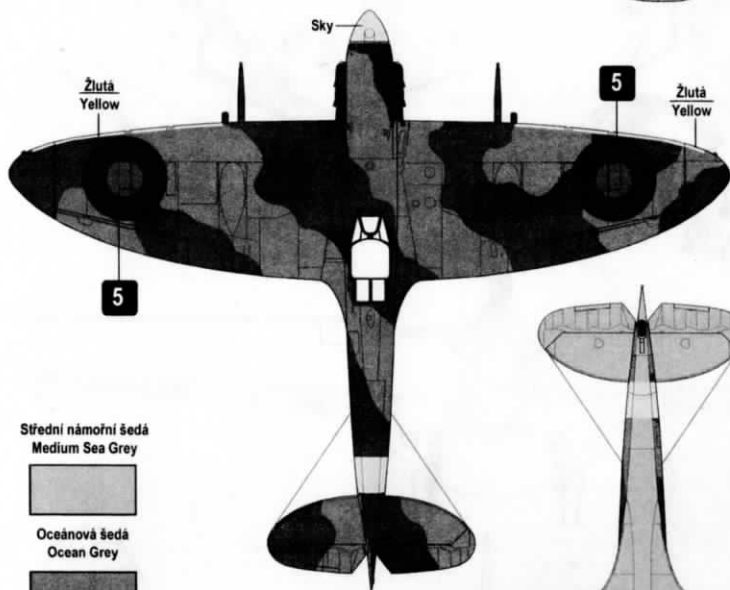
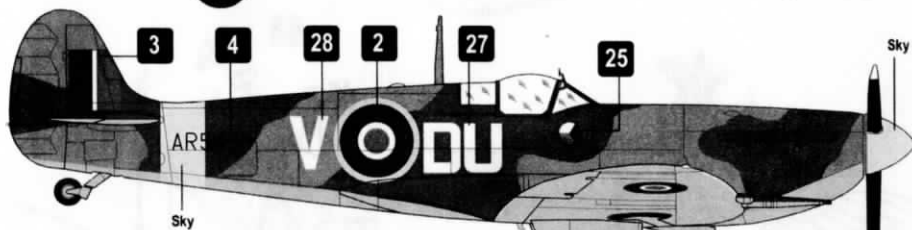
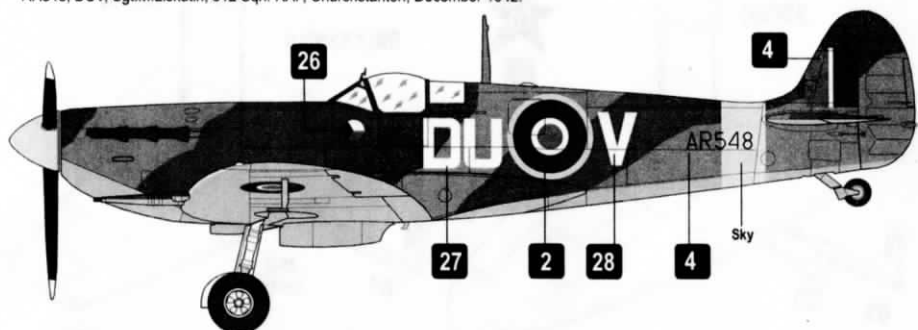

Černá
Black

Žlutá
Yellow

(vrtule/propeller)
De HAVILLAND

Spitfire Mk.Vc

A

Sředi ní námoří šedá
Medium Sea Grey

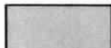

Oceánová šedá
Ocean Grey



Tmavá zelená
Dark Green

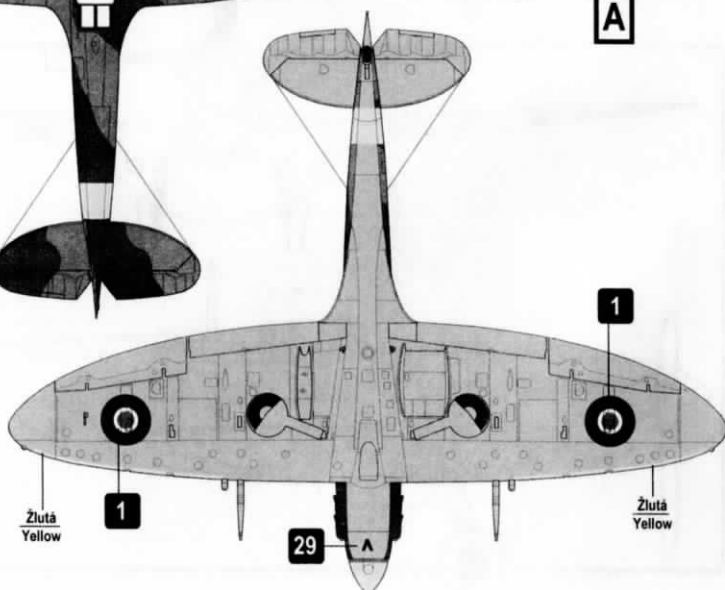

AB174, RF-Q, P/O Antoni Glowacki, 303 „Polish“ Sqn.RAF, Kirton-in-Lindsey, Srpen 1942. Během své operační činnosti dosáhl 9 vítězství jistých, 3 pravděpodobné a 5 poškození.

AB174, RFQ, P/O Antoni Glowacki, 303 „Polish“ Sqn.RAF, Kirton-in-Lindsey, August 1942.

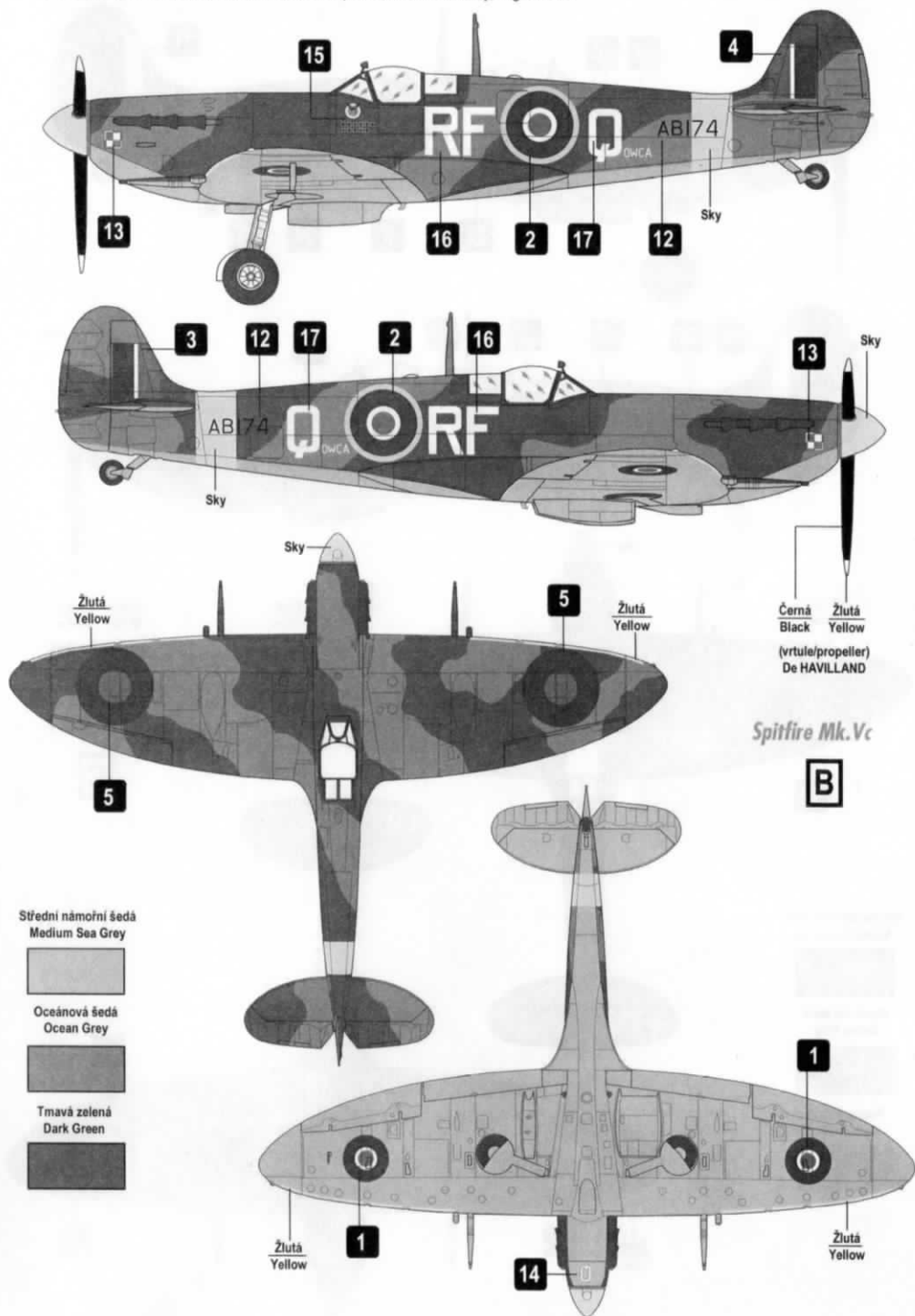

AB216, DL-Z, Nigeria Oyo Province, Sqn Ldr Robert „Bobby“ Oxspring, 91 Sqn.RAF, Hawkinge, Květen 1942. Během své operační činnosti dosáhl 15 vítězství jistých, 2 pravděpodobně, 12 poškození a 5 zničených V1.

AB216, DLZ, Nigeria Oyo Province, Sqn Ldr Robert „Bobby“ Oxspring, 91 Sqn RAF, Hawkinge, May 1942

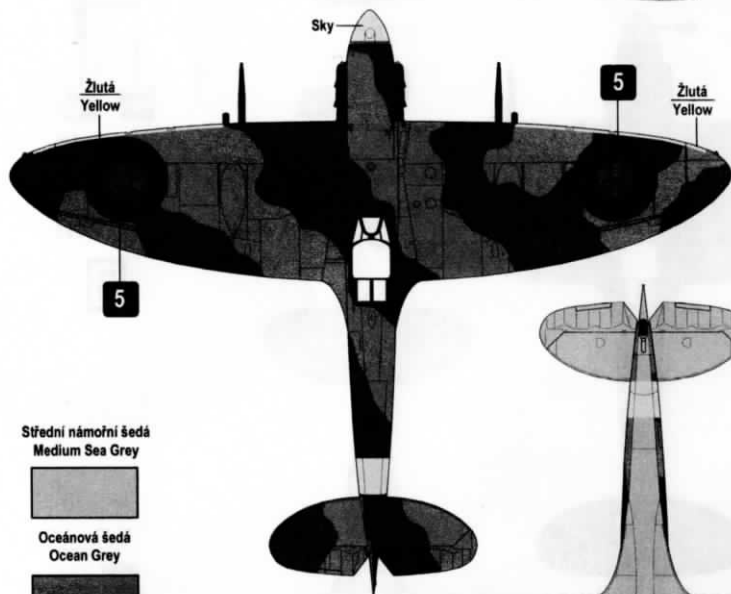
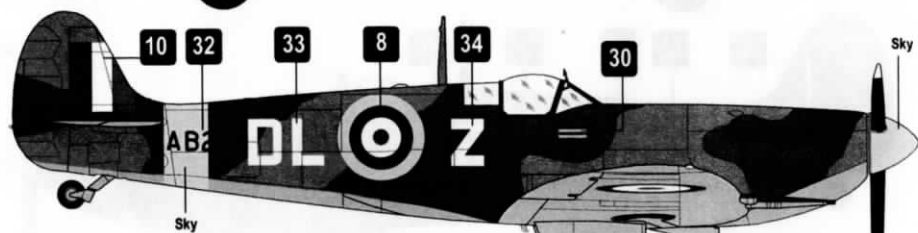
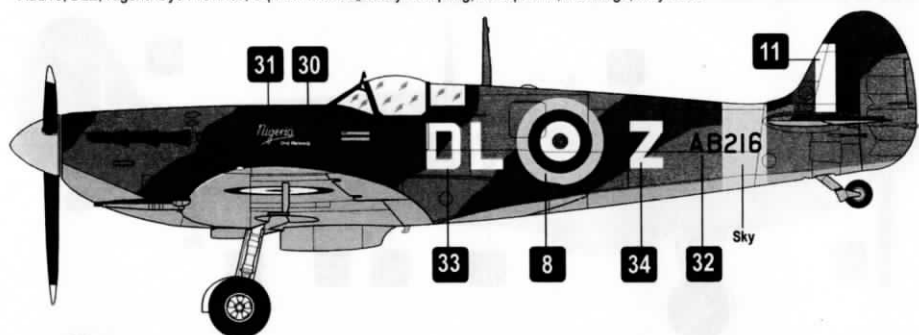

Černá Black
Žlutá Yellow
(vrtule/propeller)
De HAVILLAND

Spitfire Mk.Vc

C

Sředi ní námo ní šedá
Medium Sea Grey

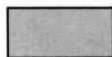

Oceánová šedá
Ocean Grey



Tmavá zelená
Dark Green

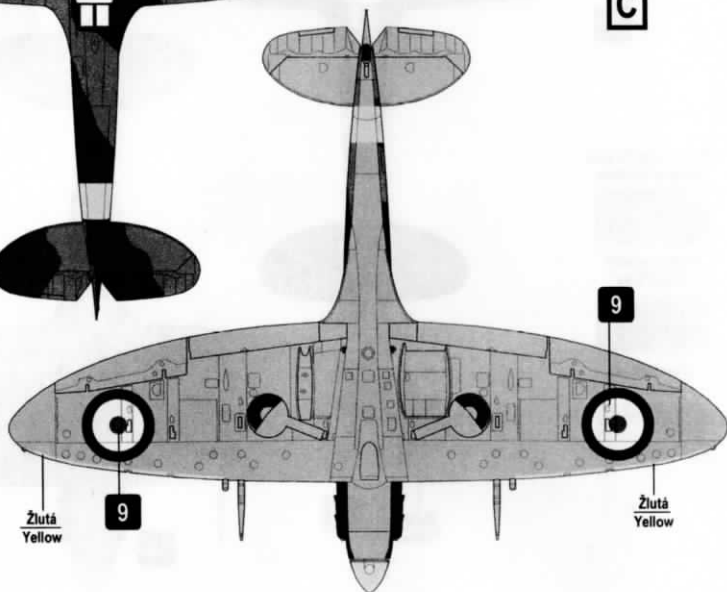

Žlutá Yellow

Žlutá Yellow

AB509, J-MC, W/Cdr John M. Checketts, velitel 142. Wingu RAF, Horne, Květen 1944. Během své operační činnosti dosáhl 15 vítězství jistých, 3 pravděpodobné, 8 poškození a 2 zničené V1.

AB509, JMC of W/Cdr John M. Checketts, 142 Wing Leader RAF, Horne, May 1944

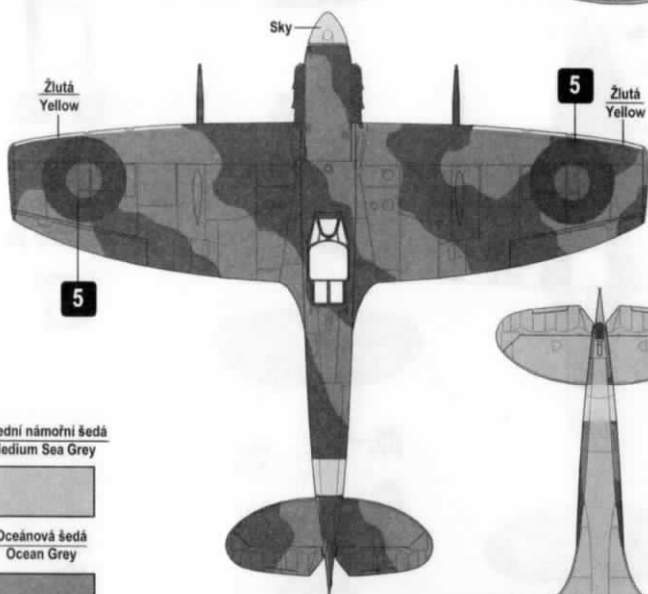
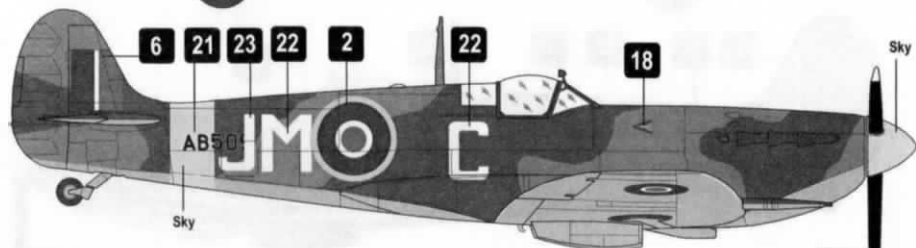
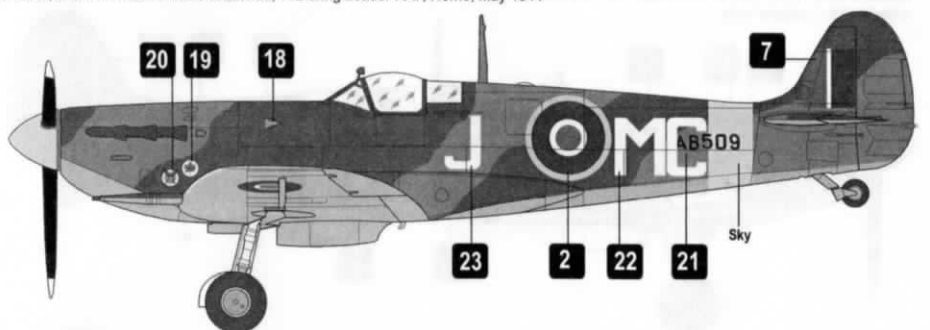

Cerná
Black

Žlutá
Yellow

(vrtule/propeller)
ROTOL

Spitfire Mk.Vc

D¹

Sředi ní námo ní šedá
Medium Sea Grey

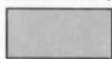

Oceánová šedá
Ocean Grey



Tmavá zelená
Dark Green

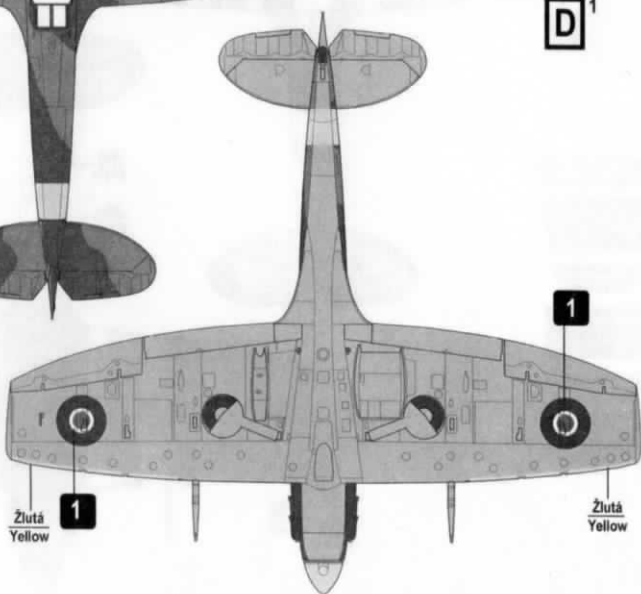

AB509, J- MC, W/Cdr John M. Checketts, velitel 142. Wingu RAF, Home, Červen 1944. Zbarvení stroje zůstalo shodné, pouze bylo doplněné o invazní pruhy a individuální kódové označení J-MC.

AB509, JMC of W/Cdr John M. Checketts, 142 Wing Leader RAF, Home, June 1944, the same camouflage and markings with D-Day striping added and the personal code.

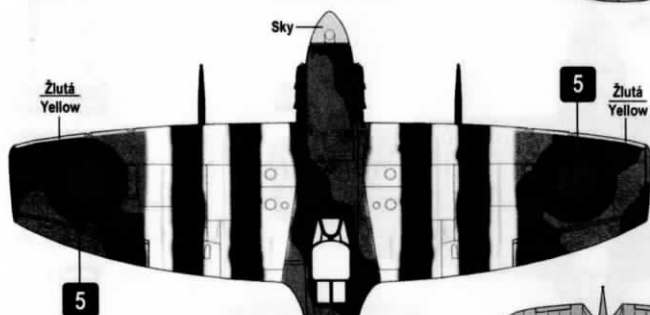
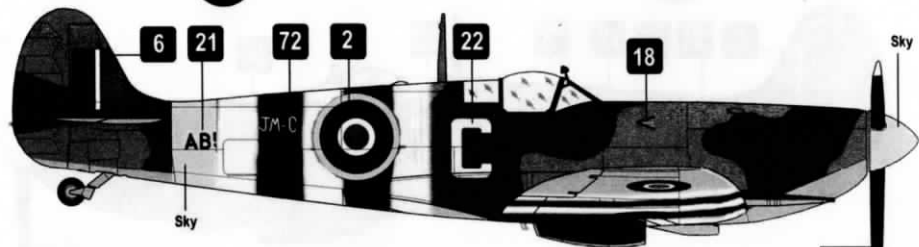
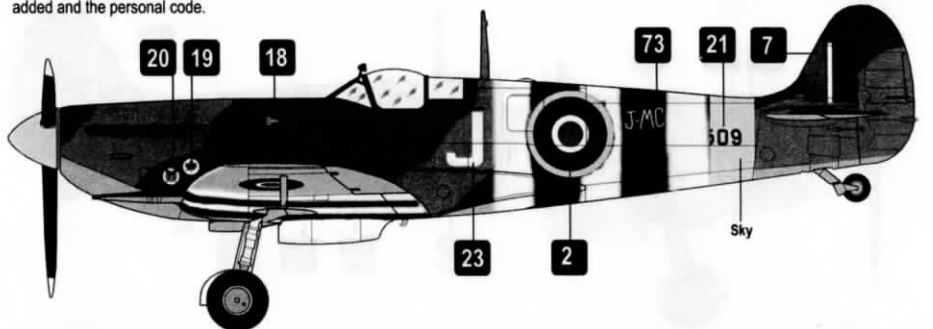

Černá
Black
Žlutá
Yellow
(vrtule/propeller)
ROTOL

Spitfire Mk.Vc

D²

Sřední námořní šedá
Medium Sea Grey

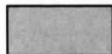

Oceánová šedá
Ocean Grey



Tmavá zelená
Dark Green

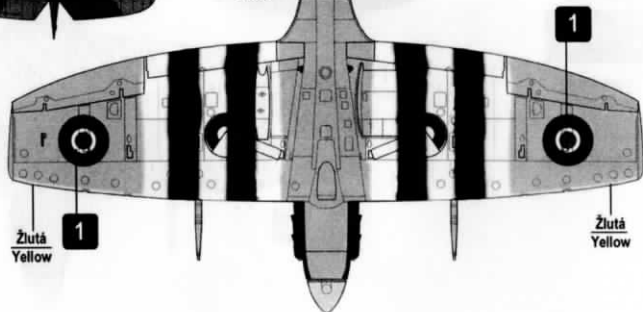
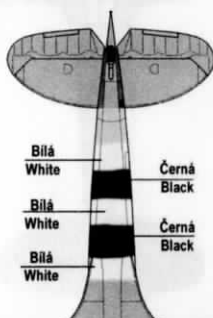

Spitfire Mk.Vc (Umístění popisek/Stencil Data)

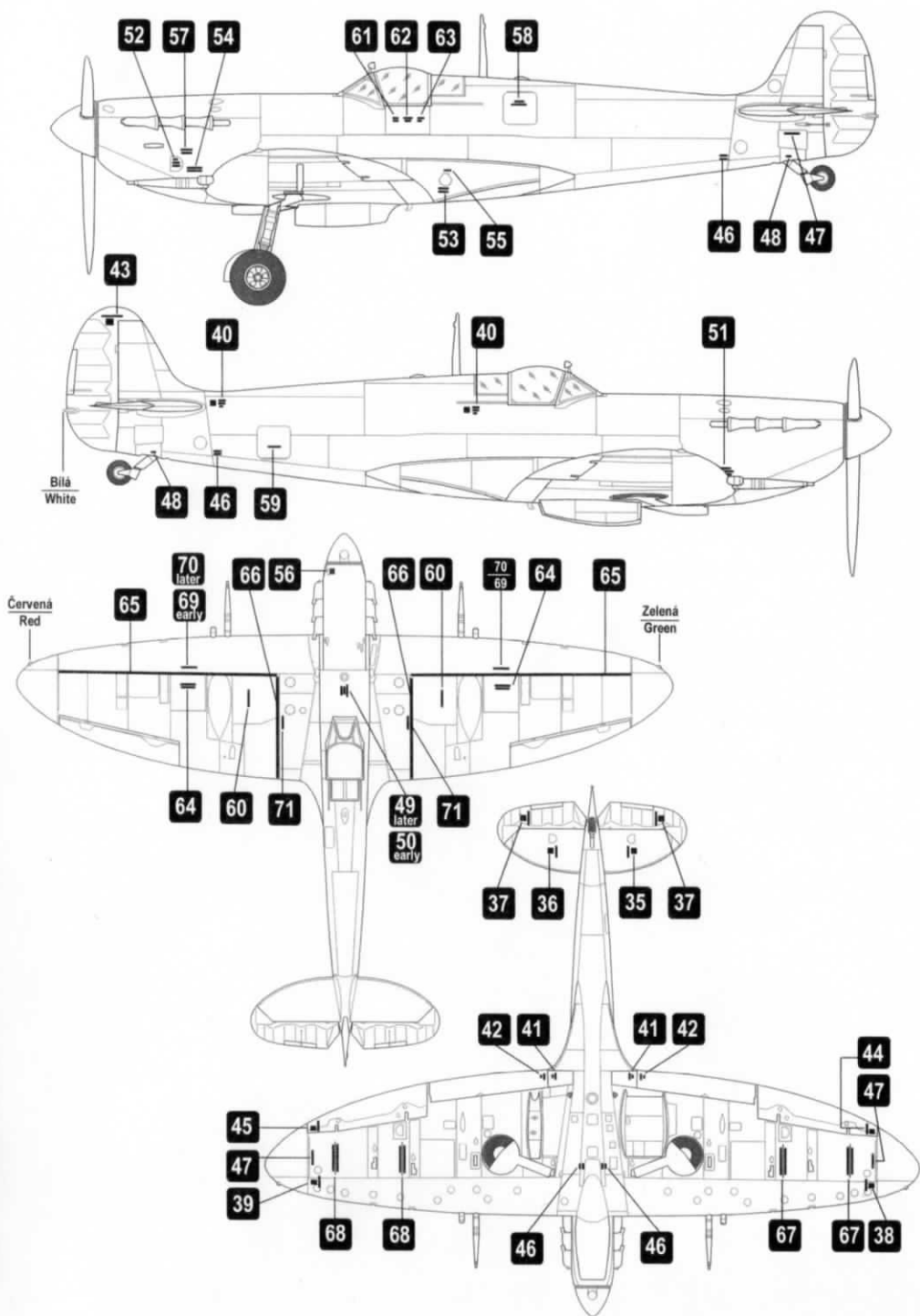

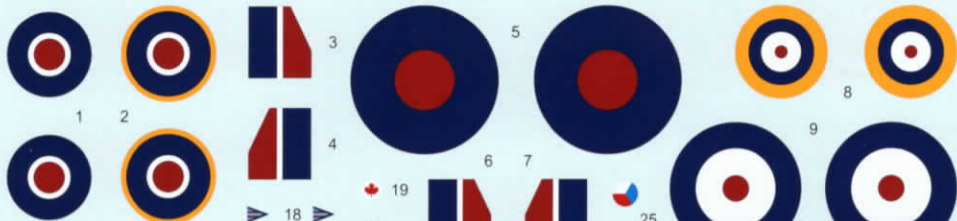

ABI74



AB509



72



24

AR548



26



10

11

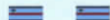

30

31

ABI74



13

AB509



14

21

73

AR548

AR548

30

RF

16

Q

15

DWCA

MC

22

J

DU

27

V

28

V

29

AB216

32

AB216

34

RF

16

Q

17

DWCA

MC

22

J

DU

27

V

28

DL

33

DL

Z

34

65

66

35	36	37	38	39	40
41	43	44			45
42	46	47			48
49	50	51	52	53	
54	55	56	57	58	
	59				
	60	61	62	63	
	64	69			WALK OUTWARD
					WALK OUTWARD
					WALK FORWARD
	67				WALK FORWARD
					70
					WALK INWARD
		68			WALK INWARD
					71



Supermarine Spitfire Mk.Vc

PRINTED BY TECHMOD