



# F-14D TOMCAT

1/48 SCALE MASSTAB 1:48 ESCALA 1/48

KIT 6365

REVELL, INC. Morton grove, Ill. Copyright 1993 All rights reserved. Made in U.S.A.

6365R4200



The Tomcat has taken its rightful place among the greatest aircraft of all time. Beloved by the US Navy and its crews, it has managed to keep an almost perfect balance of speed, range and maneuverability. Its weapons systems pack an awesome punch in both the offensive and defensive roles. And woe be to the person who tries to challenge those capabilities. From its first flight back in October, 1972, the Tomcat has been undergoing subtle and not-so subtle changes throughout its service life.

These changes have led up to the development of the "D" model, Incorporating significantly more powerful General Electric F100-GE-400 engines, all-new avionics, revised cockpits with new NACES ejection seats and onboard oxygen generating capabilities. External changes include the addition of two chin pods under the nose. Will this be the last variant of the greatest US Navy fleet defender. Only time will tell. But until then, expect to see the Tomcat flying above the Navy's supercarriers well into the future.

#### READ THIS BEFORE YOU BEGIN

- Study the assembly drawings.
- Each plastic part is identified by a number.
- Check the fit of each piece before cementing in place.
- Do not use too much cement to join parts.
- Use only cement for polystyrene plastic.
- Model may be painted to match photos on box.
- Allow paint to dry thoroughly before handling parts.
- Scrape paint from areas to be cemented.
- For better paint and decal adhesion, wash the plastic parts in a mild detergent solution. Rinse and let air dry.

#### • Chaque pièce plastique porte un numéro d'identification.

- Contrôler que chaque pièce soit bien conforme avant de la coller à sa place.
- N'utilisez pas trop de colle pour réunir les pièces.
- Utilisez uniquement une colle spéciale pour polystyrène.
- Le modèle peut être peint conformément aux photos sur la boîte.
- Laissez sécher la peinture complètement, avant de manipuler les pièces.
- Grattez la peinture sur les surfaces devant être collées.
- Pour assurer la meilleure adhésion possible de la peinture et des décalcomanies, laver les pièces de plastique avec une légère solution savonneuse. Rincer et laisser sécher à l'air.

#### LEA ESTO ANTES DE EMPEZAR

- Estudie los dibujos de ensamble.
- Cada pieza de plástico se identifica por un número.
- Verifique que cada pieza encaje bien antes de pegar en posición.
- No use demasiado pegamento para unir las piezas.
- Use únicamente pegamento para plástico de poliestireno.
- El modelo puede pintarse de acuerdo con las fotografías de la caja.
- Permita que se seque la pintura completamente antes de tocar las piezas.
- Raspe la pintura de las superficies que serán pegadas.
- Para una mejor fijación de la pintura y de las calcomanías, lávese las piezas plásticas en una solución de detergente suave. Enjuáguese y déjese secar al aire.

#### LISEZ CE QUI SUIT AVANT DE COMMENCER

##### LE MONTAGE

- Etudier les schémas d'assemblage.

BLACK	NOIR	NEGRO
ALUMINUM	ALUMINIUM	ALUMINIO
WHITE	BLANC	BLANCO



DO NOT CEMENT  
N'EST PAS COLLER  
NO USE PEGAMENTO



DECAL (DIP IN WATER)  
AUFHEBEN  
DECALCOMANIA (MOJE CON AGUA)



REMOVE AND THROW AWAY  
ENTWERFEN (ABWURFEN)  
QUITE Y TIRAR



REPEAT SEVERAL TIMES  
ARBEITEN SIE MEHRMALS  
REPETA VARIAS VECES

Revell, Incorporated has put forth every effort to create and manufacture the finest model kit available. If a part may be missing, please write to:

Revell, Incorporated  
Consumer Service Department  
395 North Third Avenue  
Des Plaines, Illinois 60016

Be sure to include the kit number, part number, description, and your return address.

If you have any problems building this model, call our modeling tips hotline at:

(800) 833-3570

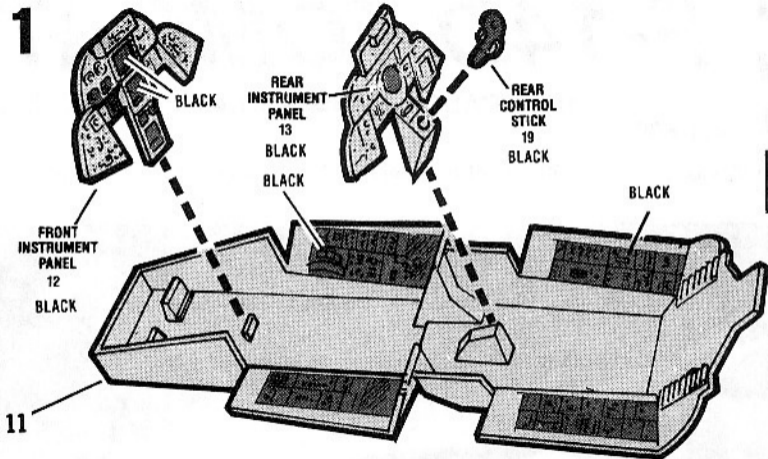
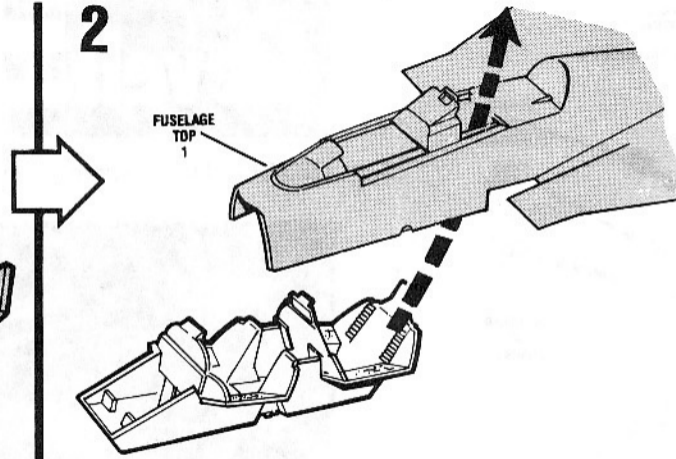
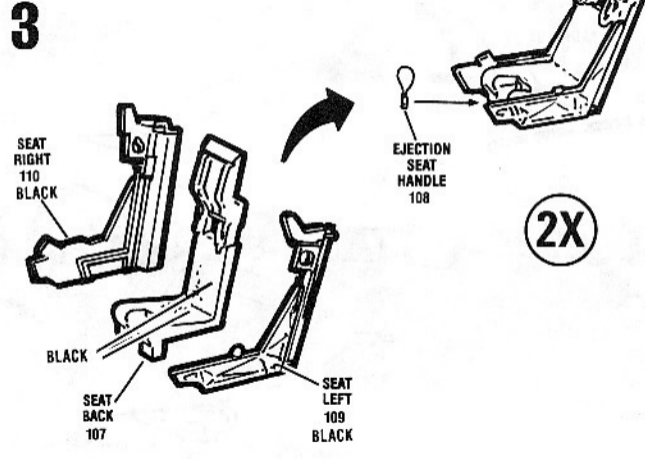
**1****2****3**

4

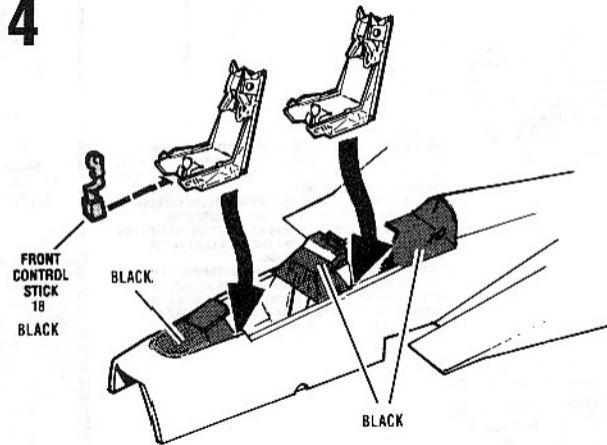

5

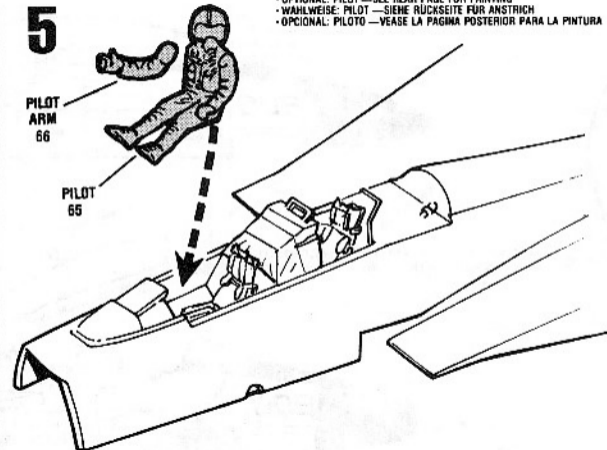

• OPTIONAL: PILOT — SEE REAR PAGE FOR PAINTING  
 • WAHLWEISE: PILOT — SIEHE RÜCKSEITE FÜR ANSTRICH  
 • OPCIONAL: PILOTO — VEASE LA PAGINA POSTERIOR PARA LA PINTURA

6

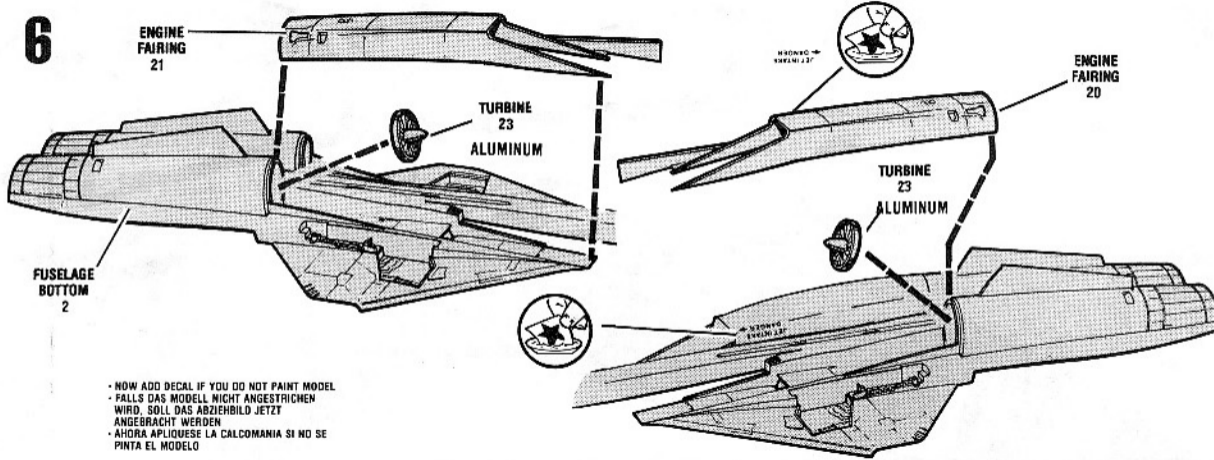

• NOW ADD DECAL IF YOU DO NOT PAINT MODEL  
 • FALLS DAS MODELL NICHT ANGESTRICHEN WIRD, SOLL DAS ABZIEHBILD JETZT ANGEBRACHT WERDEN  
 • AHORA APLIQUESE LA CALCOMANIA SI NO SE PINTA EL MODELO

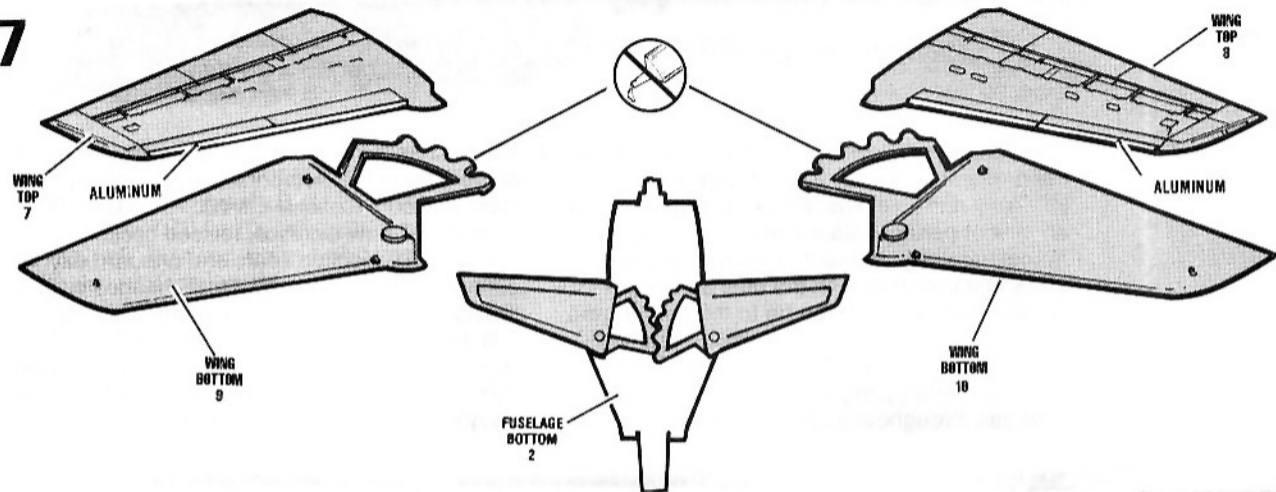
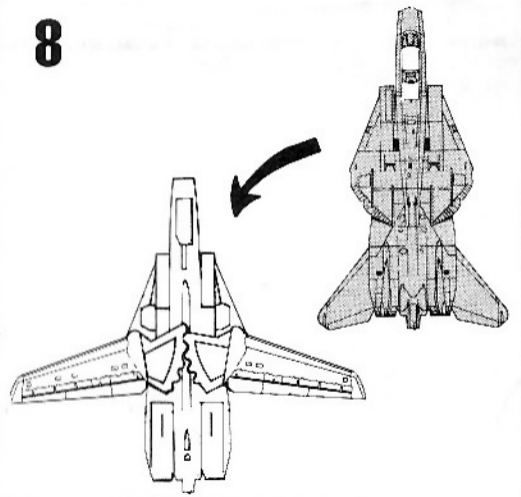
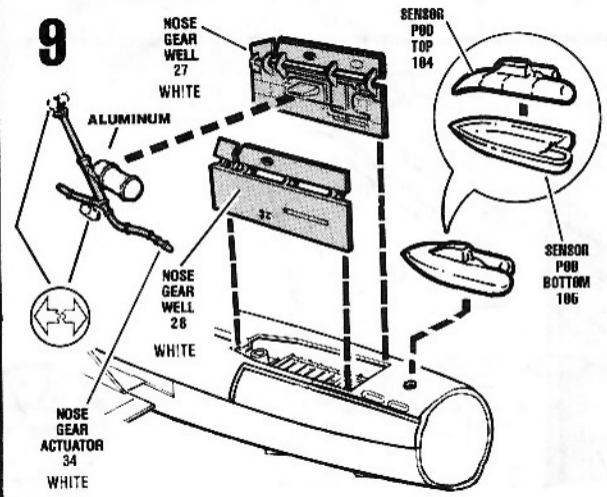
**7****8****9**

10

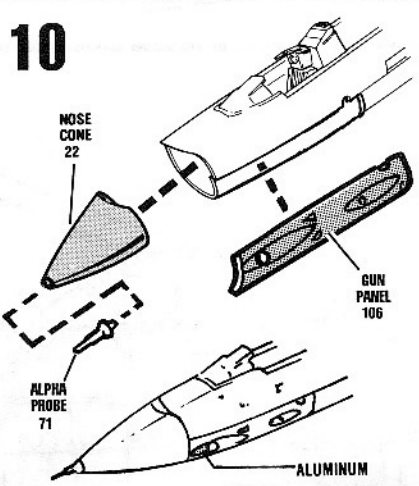

11

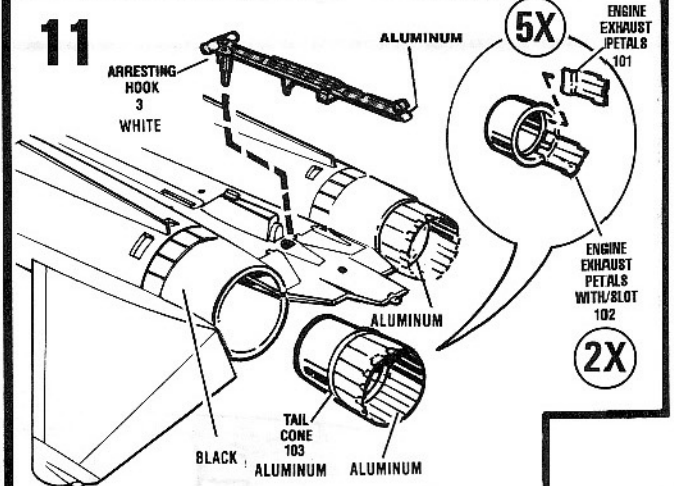

12

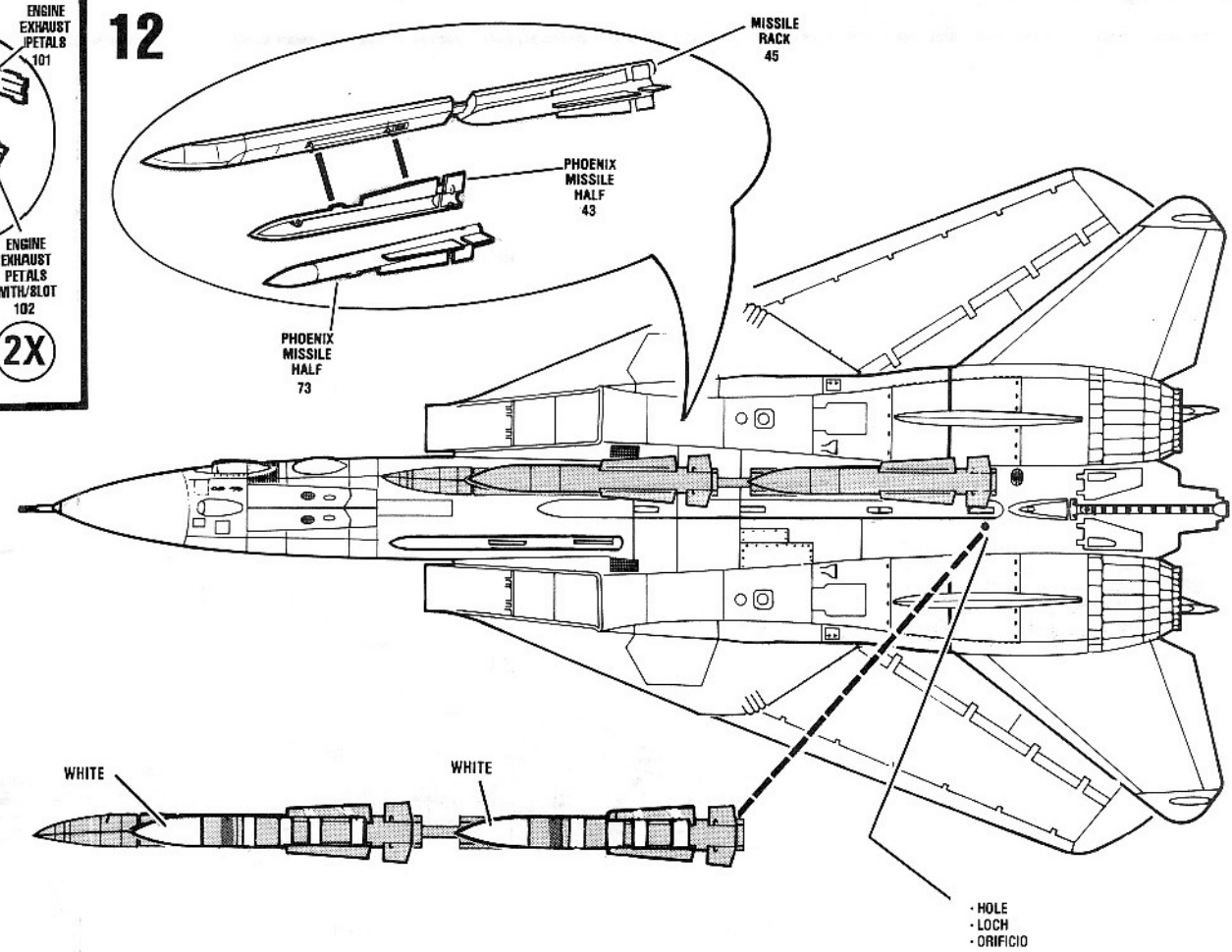

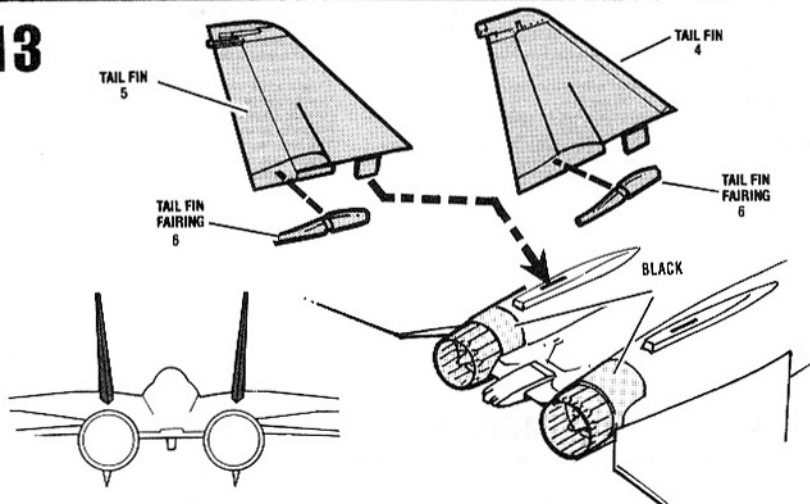
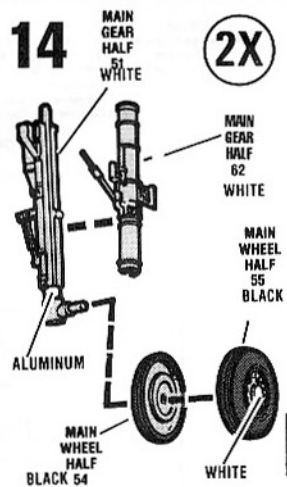
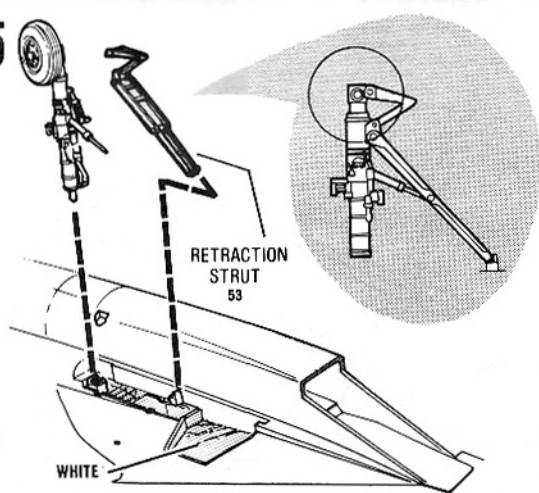
**13****14****15**

# 16

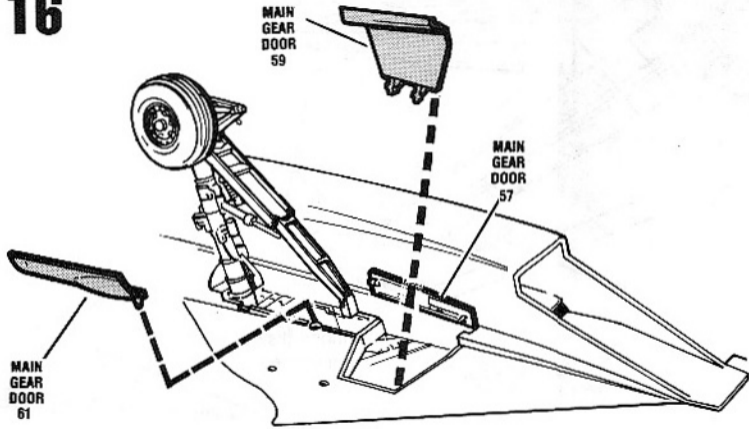

# 17

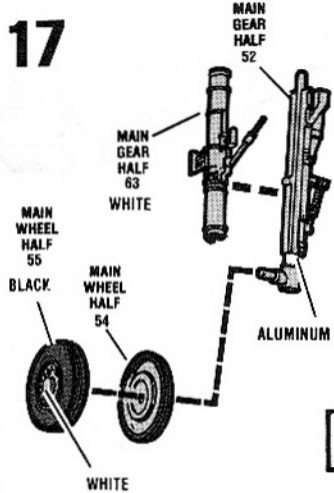

# 18

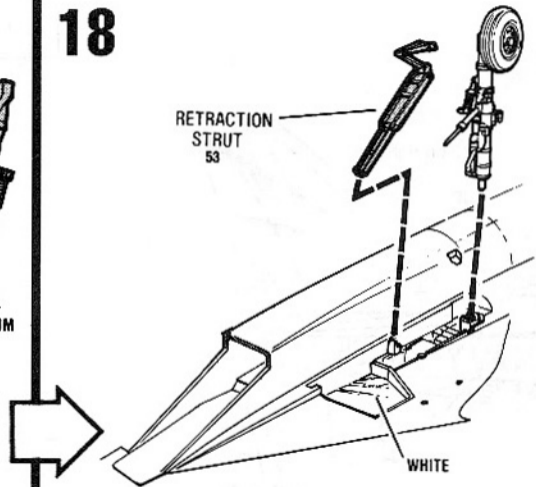

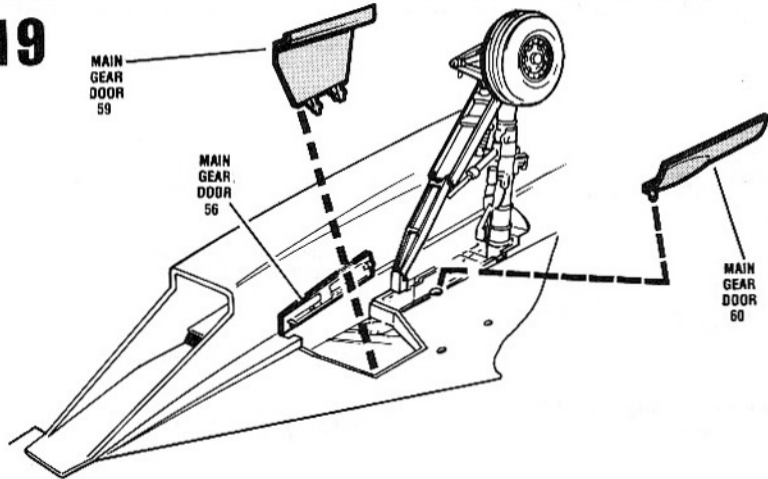
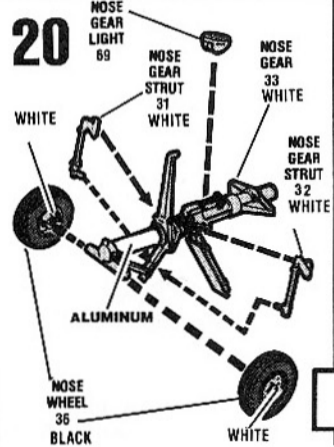
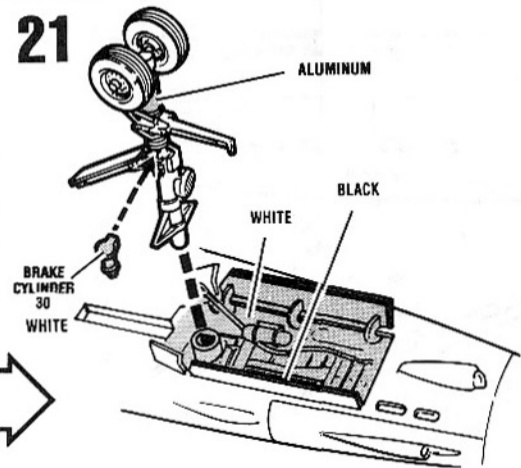
**19****20****21**



22

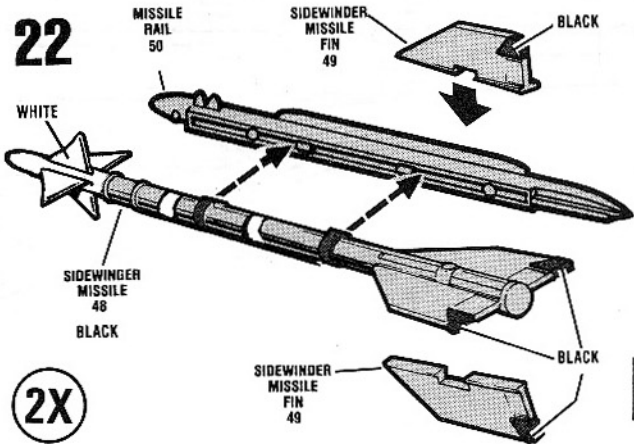

23

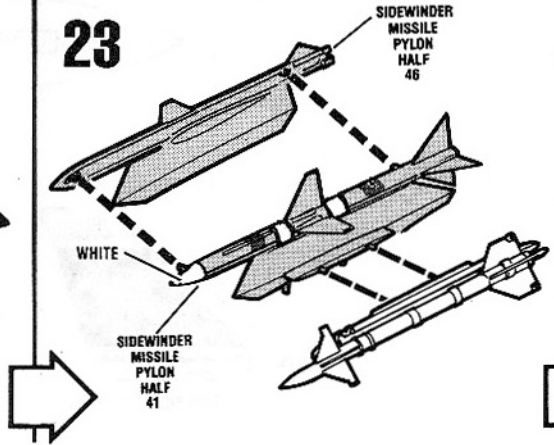

24

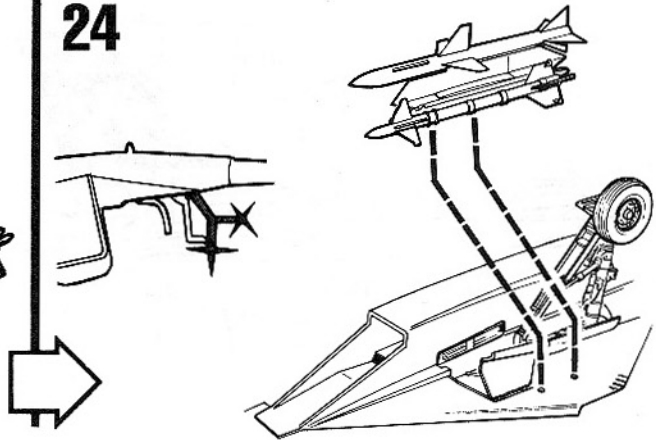

# 25

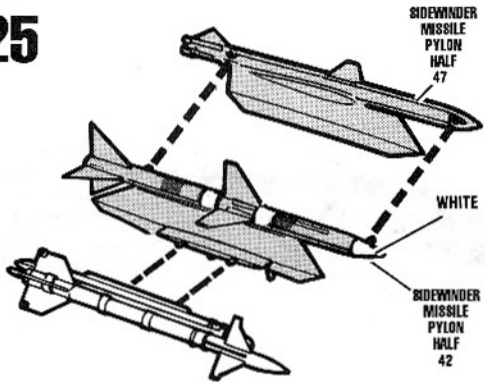

# 26

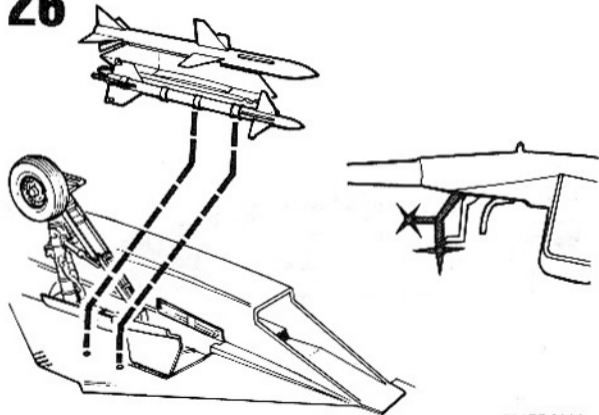

27

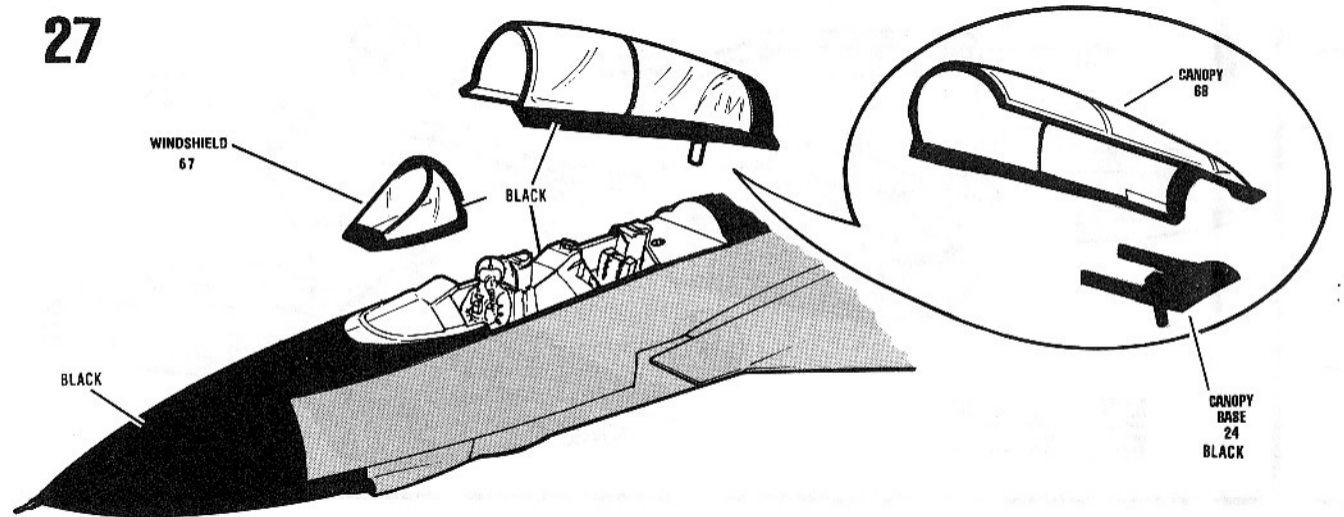

• OPTIONAL CANOPY POSITIONS - WAHLWEISE KUPPELDACHSTELLUNGEN  
 • POSICIONES OPCIONALES DE LA CARLINGA

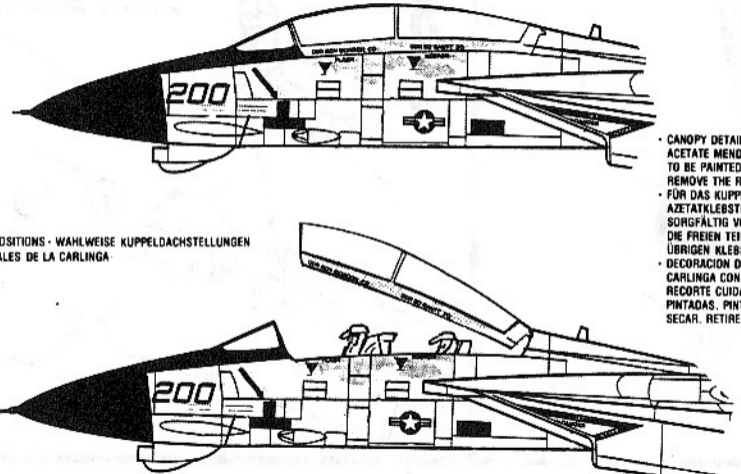

• CANOPY DETAIL—MASK ENTIRE CANOPY WITH A DULL FINISH ACETATE MENDING TAPE. CAREFULLY CUT THE TAPE FROM AREAS TO BE PAINTED. PAINT THE EXPOSED PARTS AND ALLOW TO DRY. REMOVE THE REMAINING TAPE.  
 • FÜR DAS KUPPELDACH—DAS GESAMTE KUPPELDACH MIT MATTEM AZETATKLEBSTREIFEN VERKLEIDEN. DEN KLEBSTREIFEN SORGFÄLTIG VON DEN ZU STREICHENDEN FLÄCHEN ABSCHNEIDEN. DIE FREIEN TEILE STREICHEN UND TROCKNEN LASSEN. DEN ÜBRIGEN KLEBSTREIFEN ENTFERNEN.  
 • DECORACION DE LA CARLINGA—CUBRIR ENTERAMENTE LA CARLINGA CON LA CINTA DE PEGAR DE COLOR ACETATO APAGADO. RECORTE CUIDADOSAMENTE LA CINTA. DE LAS AREAS A SER PINTADAS. PINTÉ LAS PARTES QUE QUEDEN EXPUESTAS Y DEJE SECAR. RETIRE LA CINTA DE PEGAR.

28

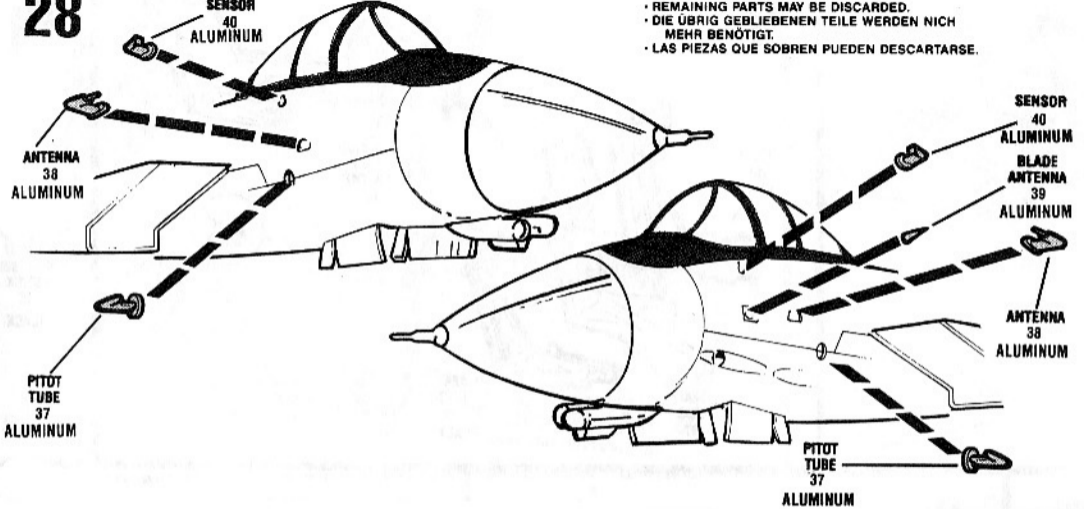

• REMAINING PARTS MAY BE DISCARDED.  
 • DIE ÜBRIG GEBLIEBENEN TEILE WERDEN NICHT MEHR BENÖTIGT.  
 • LAS PIEZAS QUE SOBREN PUEDEN DESCARTARSE.

PITOT TUBE 37 ALUMINUM

GREEN LIGHT  
GRÜNES LICHT  
LUZ VERDE

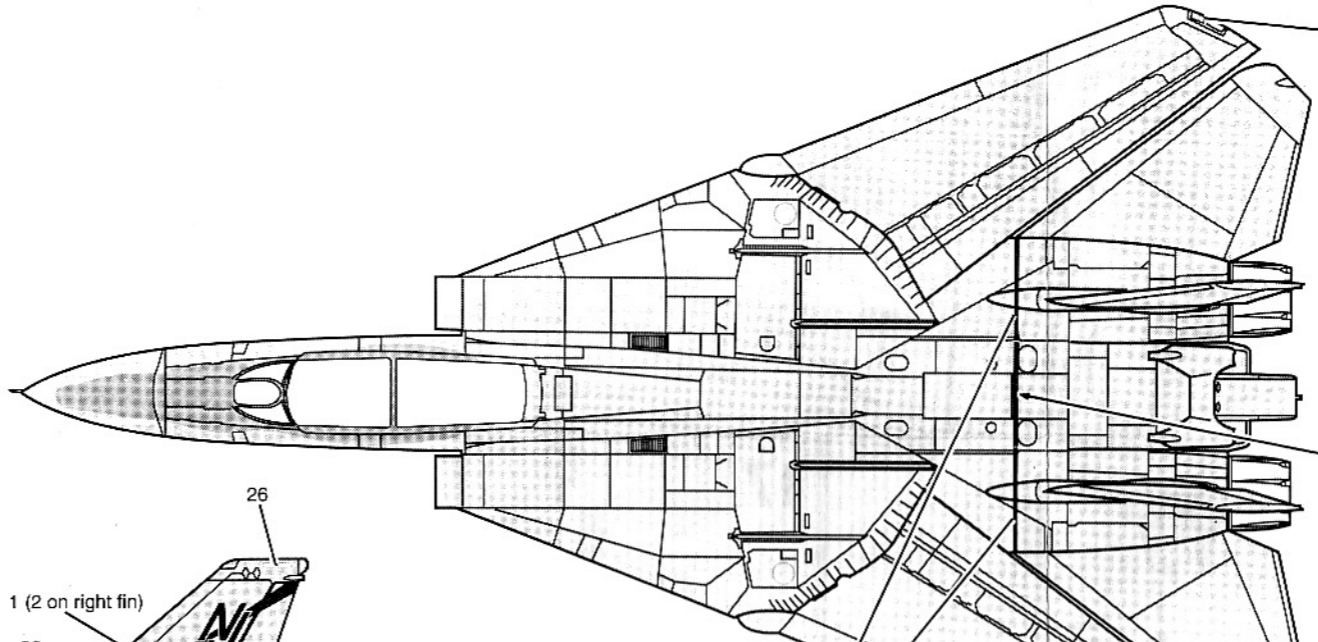

RED LIGHT  
ROTES LICHT  
LUZ ROJA

22 Inboard side of left intake

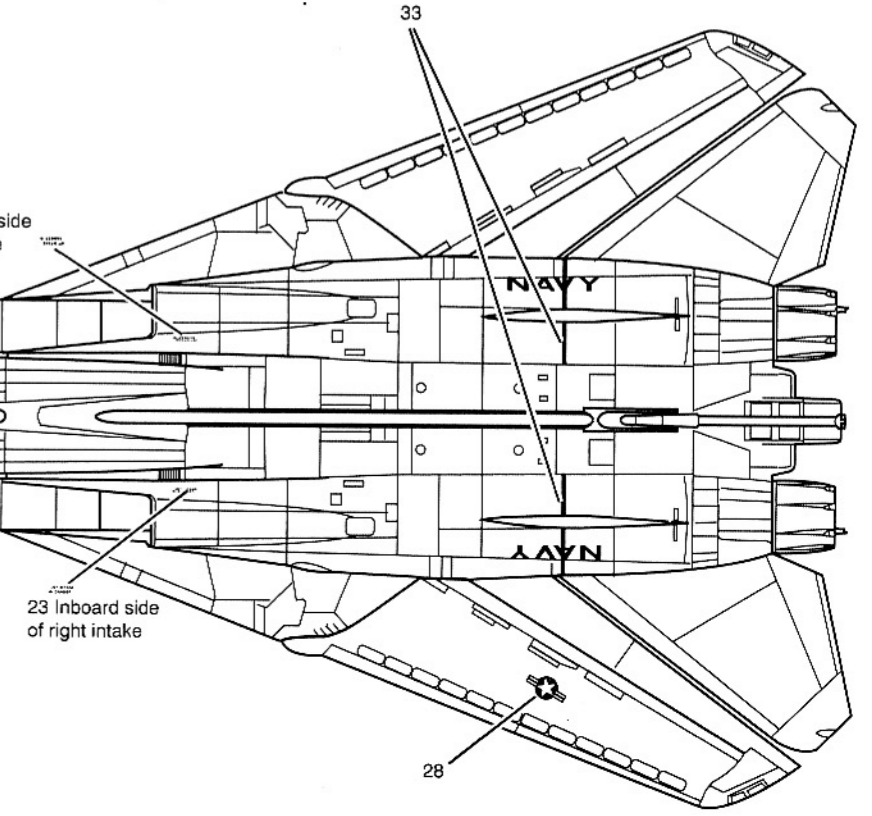

23 Inboard side of right intake

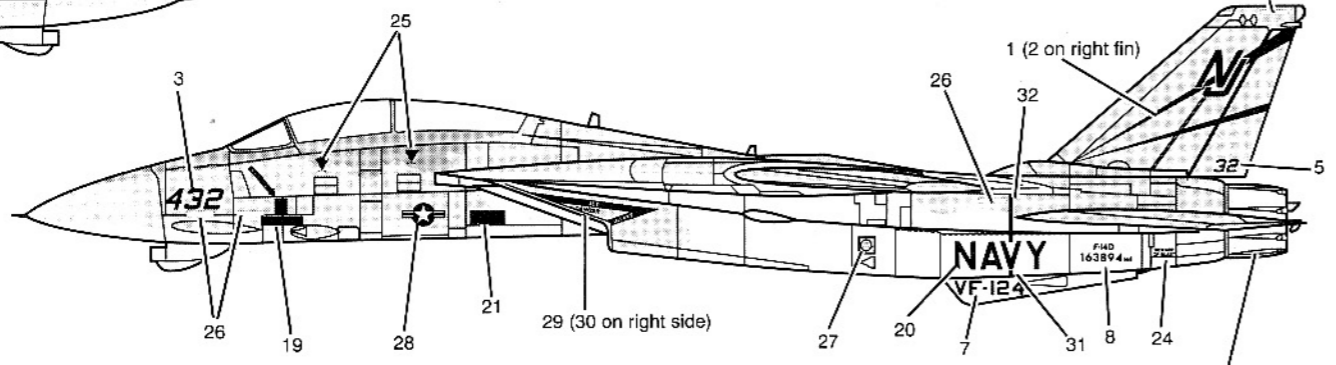
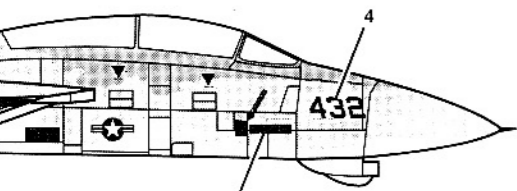

Stainless Steel

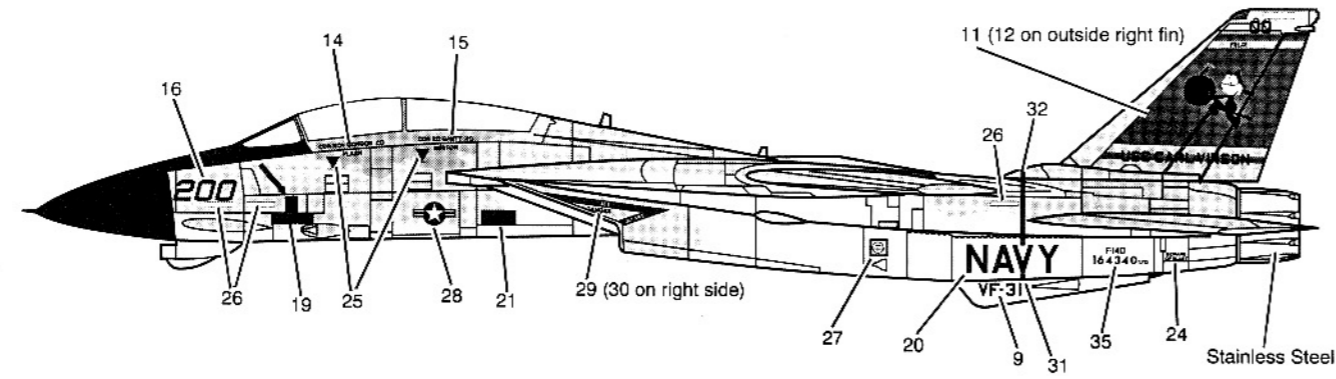
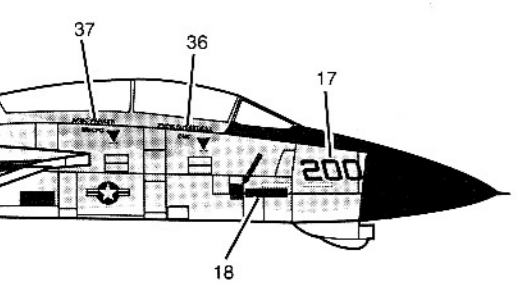

Stainless Steel

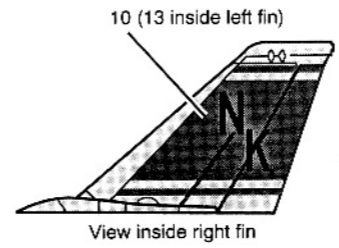

View inside right fin

11 (12 on outside right fin)

10 (13 inside left fin)

REVELL-MONOGRAM 1993  
ALL RIGHTS RESERVED

F-14D TOMCAT 4729R4300

3 4  
**432 432**

35 5 6  
F-14D  
164340<sub>170</sub>  
**32 32**

F-14D  
164340<sub>170</sub>

21  
**NAVY**  
8  
F-14D  
163894<sub>165</sub>  
**NAVY**  
20  
F-14D  
163894<sub>165</sub>

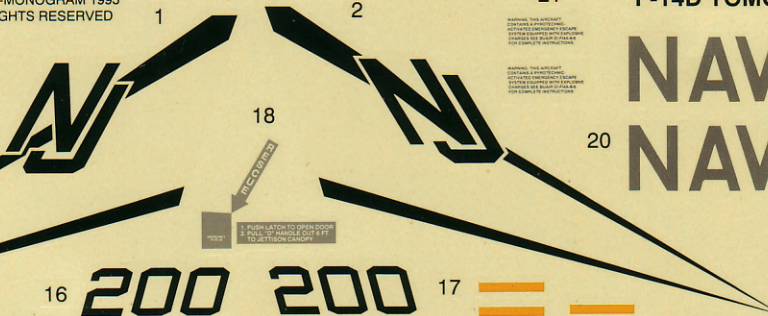
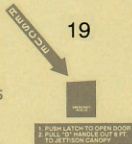

16 **200 200** 17

7  
VF-31 VF-124  
9  
VF-31 VF-124

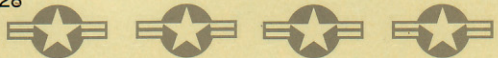

22 JET INTAKE DANGER → BEWARE OF BLAST  
23 JET INTAKE ← DANGER BEWARE OF BLAST  
24  
25  
26  
27  
28  
29  
30  
31  
32  
33  
34  
35  
36 PNCM QUEBEDEAX CMC  
37 AFMC PARKER MMCPO

14 CDR ROY GORDON CO  
FLASH

00

00

FELIX

FELIX



USS CARL VINSON

CDR ED GANTT XO  
NESTOR

USS CARL VINSON

