



ISRAEL

IAI KFIR C2/C7



1/48 UNASSEMBLED MODEL KIT

INSTRUCTIONS



ISRAEL IAI KFIR C2/C7

幼獅戰鬥機

Israel Aerospace Industries Ltd. "Kfir" (Hebrew: Lion Cub) is an Israeli built all-weather, multi-role combat aircraft based on a modified Dassault Mirage 5 airframe with Israeli avionics and an Israeli made version of the General Electric J79 turbojet engine.

The Kfir entered service with the IAF in 1975 with the first units being assigned to the 101st "First Fighter Squadron". Over the following years, several other squadrons were also equipped with the new aircraft. The role of the Kfir as the IAF's primary air superiority asset was short-lived due, in part, because the first F-15 Eagle's from the United States were delivered to Israel in 1976.

The Kfir's first recorded combat action took place on November 9th, 1977, during an Israeli air strike on a training camp at Tel Azia, Lebanon. The only air victory claimed by a Kfir during service with the IAF occurred on June 27th, 1979 when a Kfir C2 shot down a Syrian MiG-21.

During the Israeli-Lebanese war in 1982 (Operation "Peace for Galilee"), the IAF was able to use both F-15's and F-16's for their air superiority roles leaving the Kfir to carry out unescorted strike missions. Shortly afterwards, all IAF C2's began to be upgraded to the C7 version with an enhanced weight performance, making the Kfir more suitable to the new fighter-bomber role. During the second half of the 1990's, the Kfir was withdrawn from active service in the IAF after almost twenty years of continuous service.

以色列飛機工業公司製造的“幼獅” Kfir 是以色列製造的全天候多用途作戰飛機，以法國達索公司幻影5的機身為基礎進行改良並加裝了以色列的航空電子設備和以色列的國產版通用電氣J79渦扇噴射發動機。

“幼獅”於1975年開始服役於以色列空軍，第一台被分配到第101“第一戰士”中隊。在隨後的幾年中，其他幾個中隊都配備了新的飛機。於1976年第一架F-15鷹式戰鬥機從美國交付到以色列後，“幼獅”作為以色列空軍主要空中優勢戰鬥機的短暫任務週期就結束了。

1977年11月9日，以色列空襲一個黎巴嫩游擊隊訓練營。是“幼獅”的第一個有記錄的作戰行動，“幼獅”戰鬥機的唯一空戰勝利在1979年6月27日發生，編號874的以色列空軍“幼獅”C2擊落了一架敘利亞軍米格-21戰鬥機。

1982年以色列與黎巴嫩戰爭(加利利和平行動)的時候，以色列空軍的F-15和F-16戰鬥機發揮了強大的空中優勢的作用，讓“幼獅”可在沒有護航的情況下進行對地打擊空襲任務。不久之後，所有以色列空軍“幼獅”C2開始升級到C7版本，增強了負重能力和對地攻擊功能，使得“幼獅”更適合執行戰鬥/轟炸的作戰任務。在20世紀90年代後半期，經過近20年的作戰生涯，“幼獅”戰鬥機從以色列空軍退役。



★ 產品不適合8歲以下的兒童。
 ★ 產品中含有帶尖點的小零件。
 ★ 對於3歲以下兒童當心因窒息產生的危害。

NOT SUITABLE FOR CHILDREN UNDER 8 YEARS.
 CONTAINS FUNCTIONAL SHARP POINTS CONTAINS
 SMALL PARTS. BEWARE OF CHOKING HAZARD OF
 CHILDREN UNDER 3 YEARS.

PAINT AND COLOR USED

1	白色 White		2	透明紅 Clear Red		3	棕啡色 Brown	FS 30219
4	紅色 Red	FS 11350	5	透明藍 Clear Blue		6	綠色 Green	FS 34227
7	黃色 Yellow		8	卡其綠色 Khaki Green	FS 34097	9	沙漠黃色 Sand Yellow	FS 33531
10	銀色 Silver		11	燒鐵色 Burnt Iron		12	淺綠色 Light Green	FS 35622
13	橄欖色 Olive Drab	FS 34129	14	飛機灰色 Aircraft Gray	FS 26251	15	灰白色 Grayish White	FS 17875
16	淺藍色 Light Blue	FS 15450	17	車胎黑 Tire Black	FS 25049			
18	鋼鐵色 Steel		19	灰色 Gray	FS 36320			
20	啞黑色 Flat Black	FS 25049	21	淺灰色 Light Gray	FS 36375			



This kit provides a choice of 5 types of markings. Select one before assembly.
 本模型提供5種塗裝，請於組裝前選擇合適的塗裝。

A Kfir C2 SMF5201. 10th Fighter Squadron. Sri Lanka AF, Katunayake AB, 2011

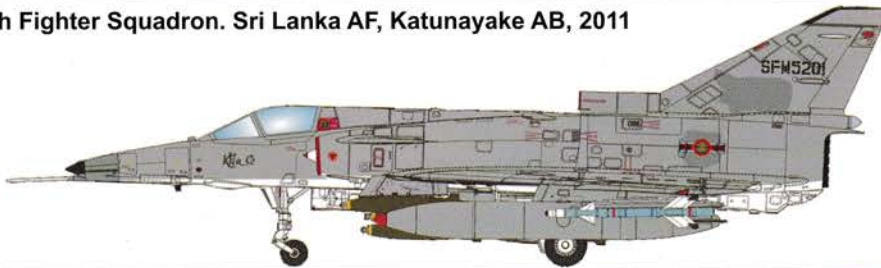

B Kfir C7 #543 "Zohar". The Arava Guardians Squadron. Israeli AF 1990



C Kfir C2 N401AX. ATAC. U.S.A.

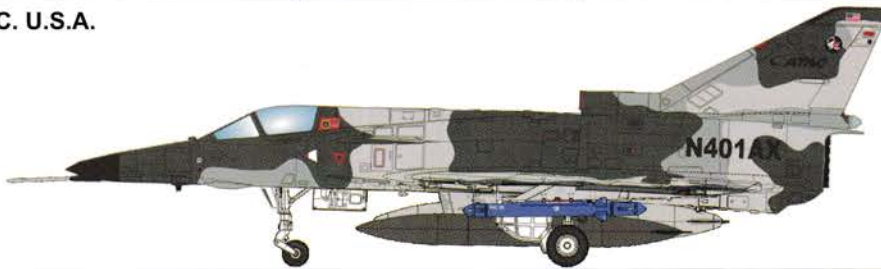

D Kfir C2 FAE 905. 2113 Squadron. Ecuadorian AF 1998

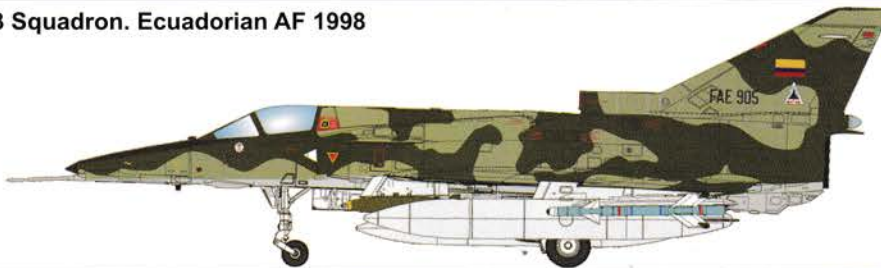

E Kfir C7 FAC 3043. 111 Squadron. Colombian AF

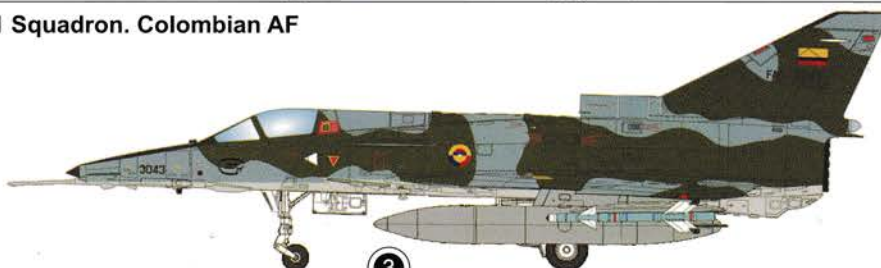

Kfir C2 FAE 905. 2113 Squadron. Ecuadorian AF 1998

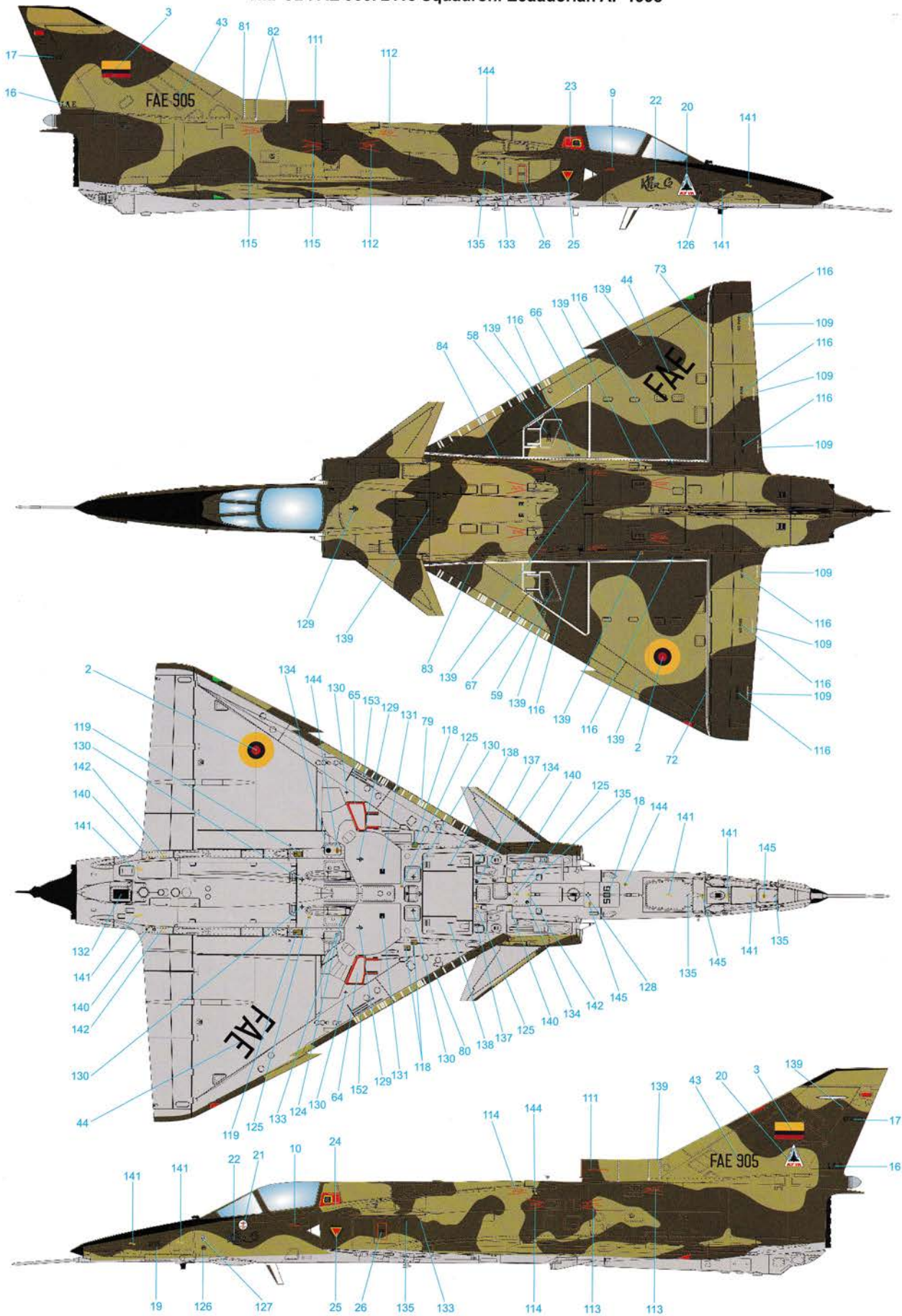

FS 36622 311 FS 34258 ~50% 39+ 50% 312 FS 34079 309 FS 37875 1 FS 31302 4 FS 37038 33

Kfir C7 FAC 3043. 111 Squadron. Colombian AF

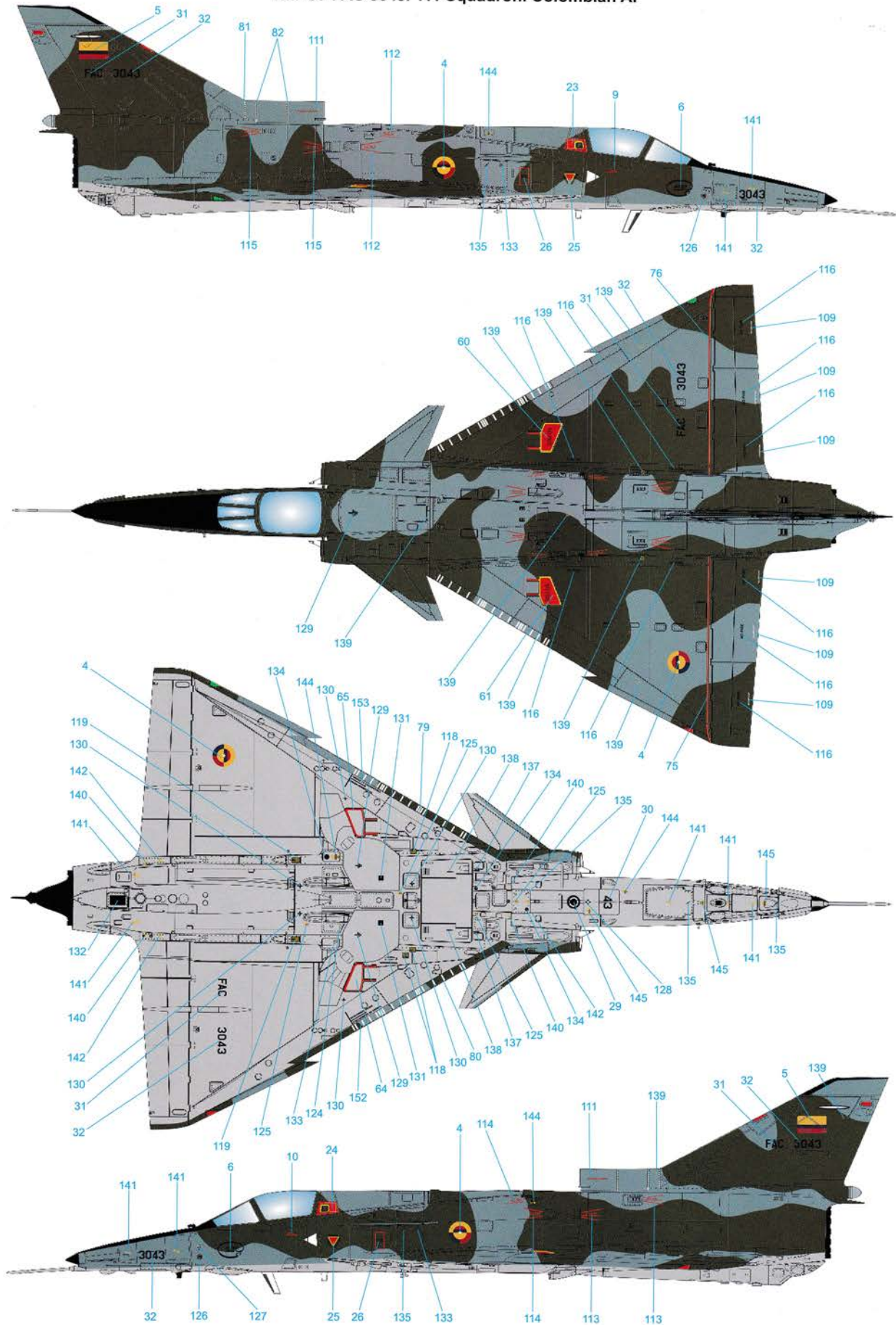

- FS 36622 311
- FS 35237 337
- FS 34079 309
- FS 37875 1
- FS 31302 4
- FS 37038 33

Painting and marking of external stores

- FS 36375 308
- FS 33531 313
- FS 30219 310
- FS 31302 4
- FS 35414 20
- FS 17038 2
- Steel 28
- FS 17875 1
- FS 34151 ~12
- FS 15180 ~H15
- FS 17865

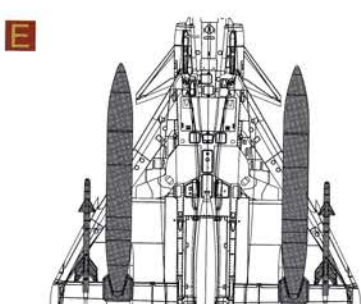
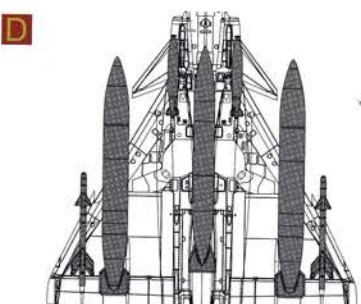
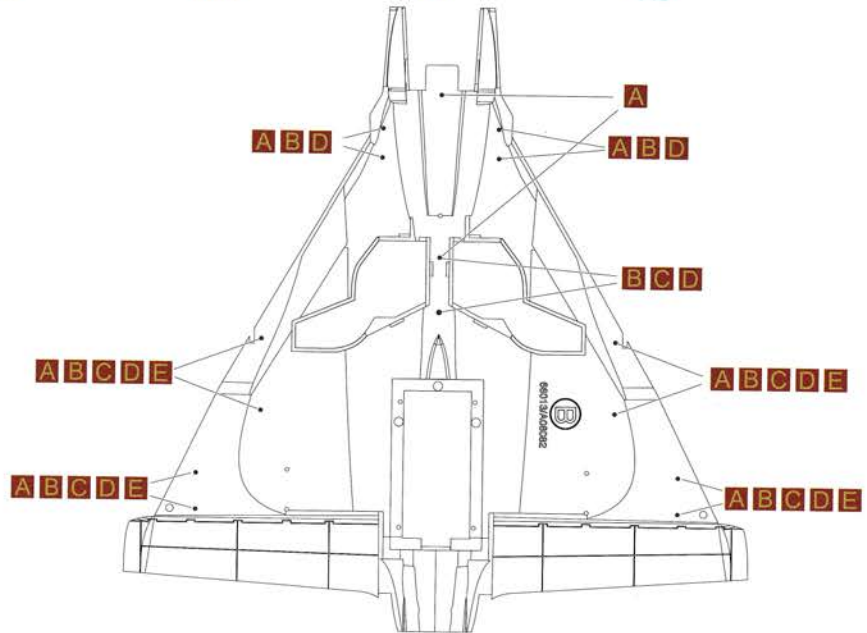
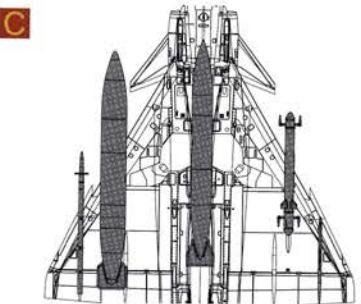
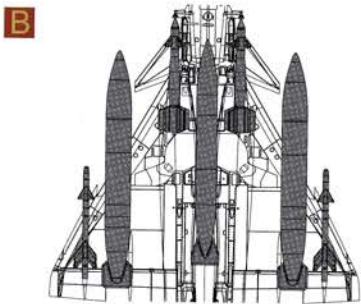
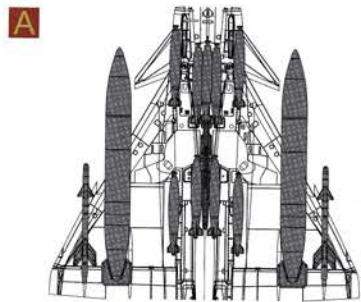
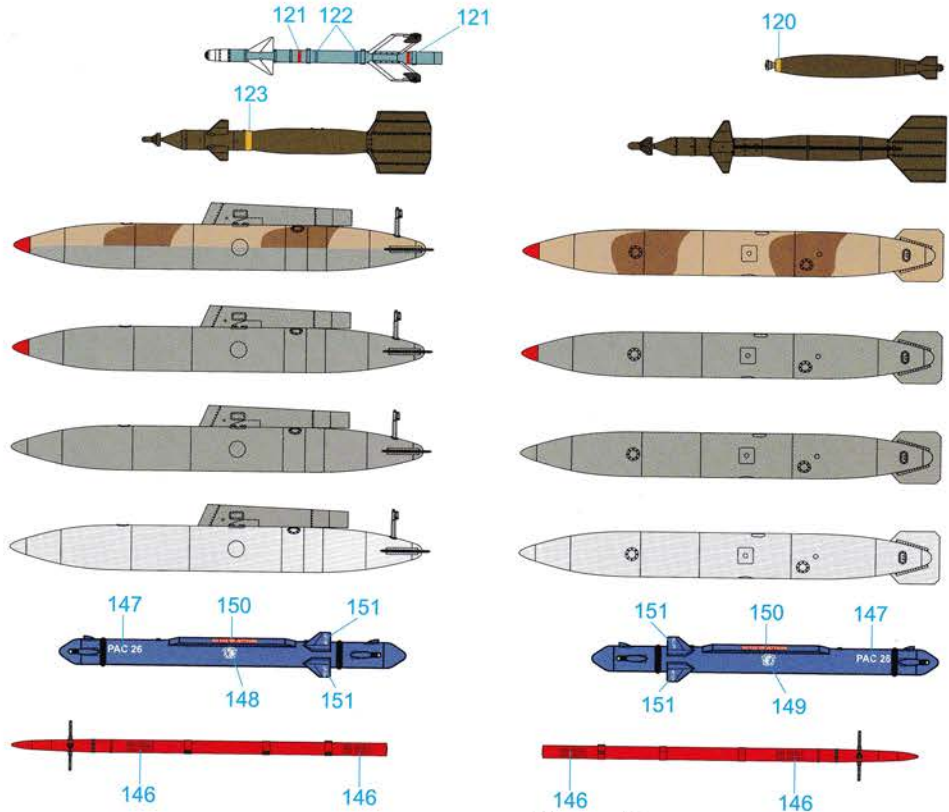

1 Attaching Cockpit and Fuselage

組裝座艙及機身

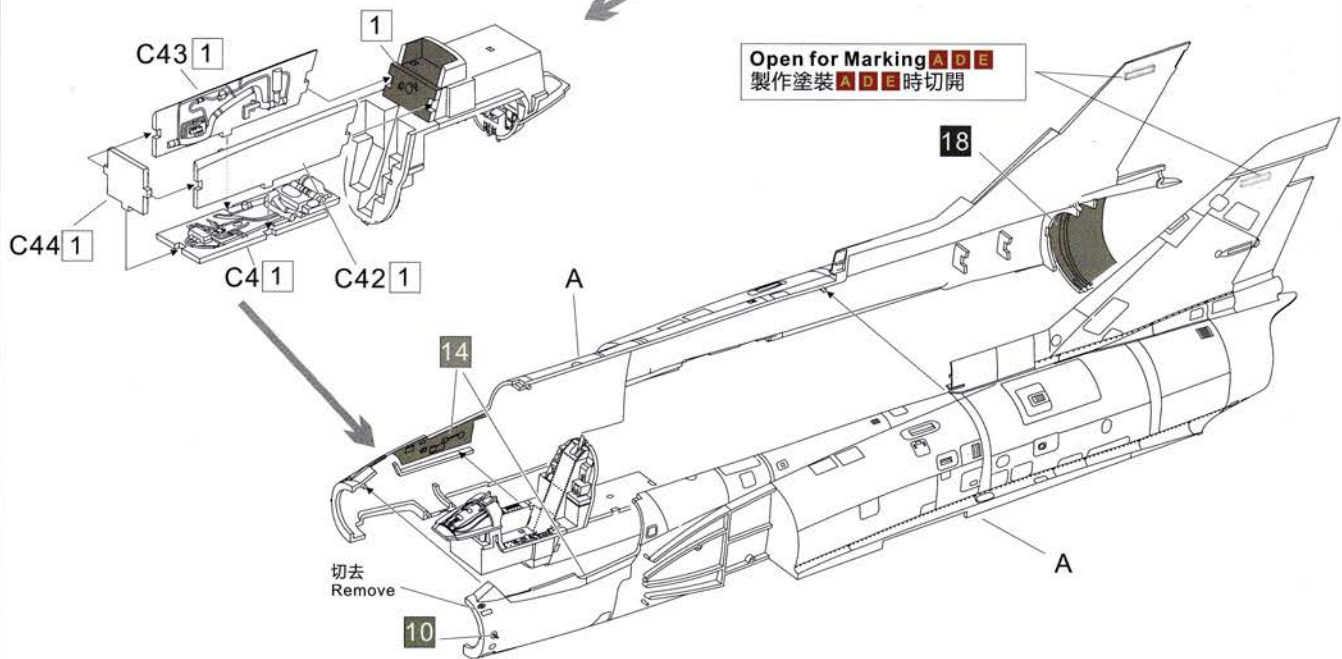
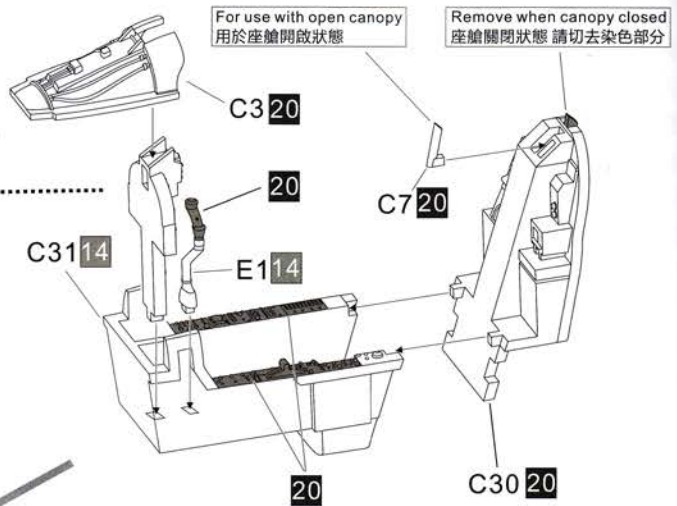
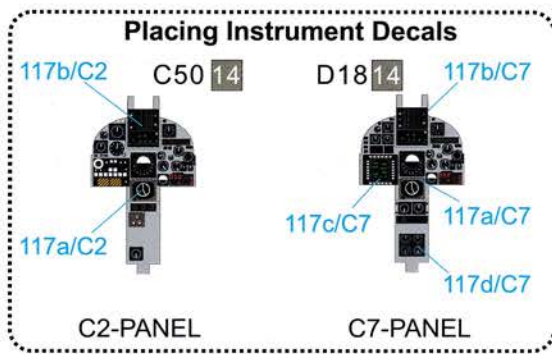

2 Attaching Main Landing Gear

組裝主起落架艙

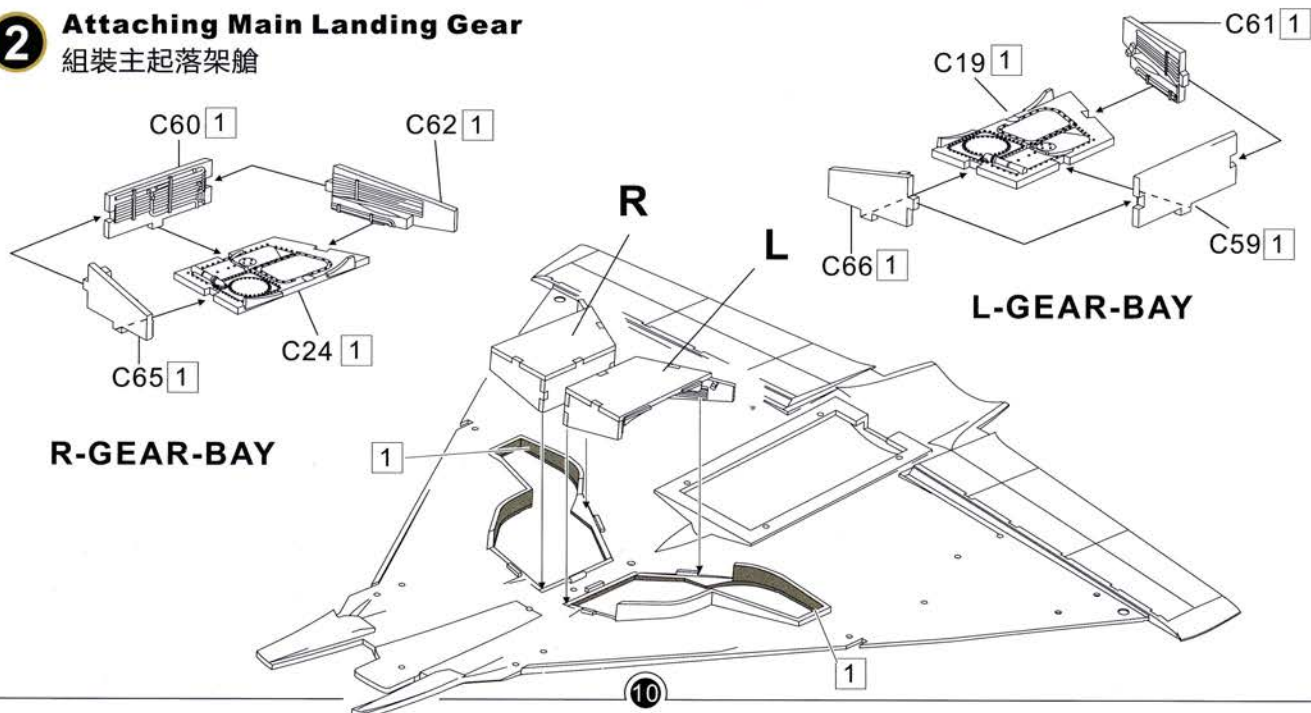

3 Attaching Main Wings and Top Fuselage
組裝主機翼及上機身

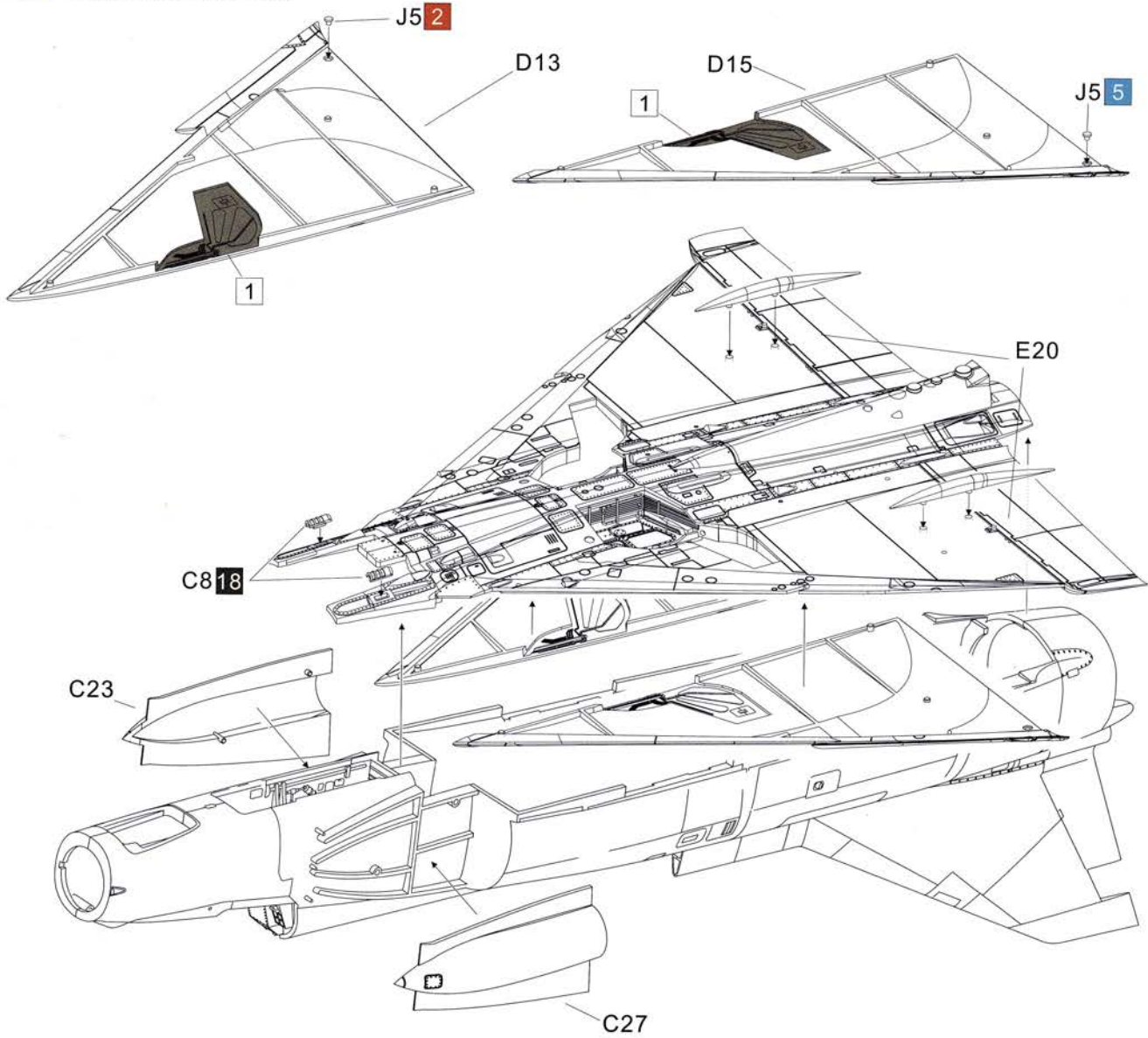

4 Attaching Air Intakes, Canards and Upper Fuselage Parts
組裝進氣口、前翼及機身上方小零件

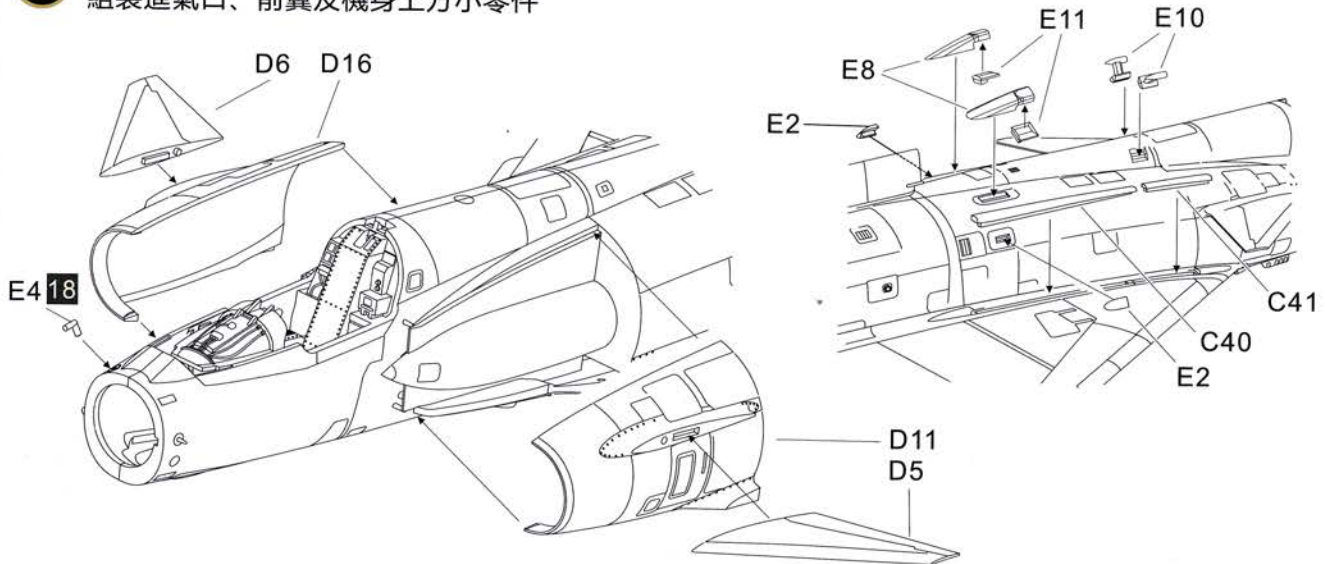

5 Attaching Main Landing Gear Doors
組裝主起落架艙門

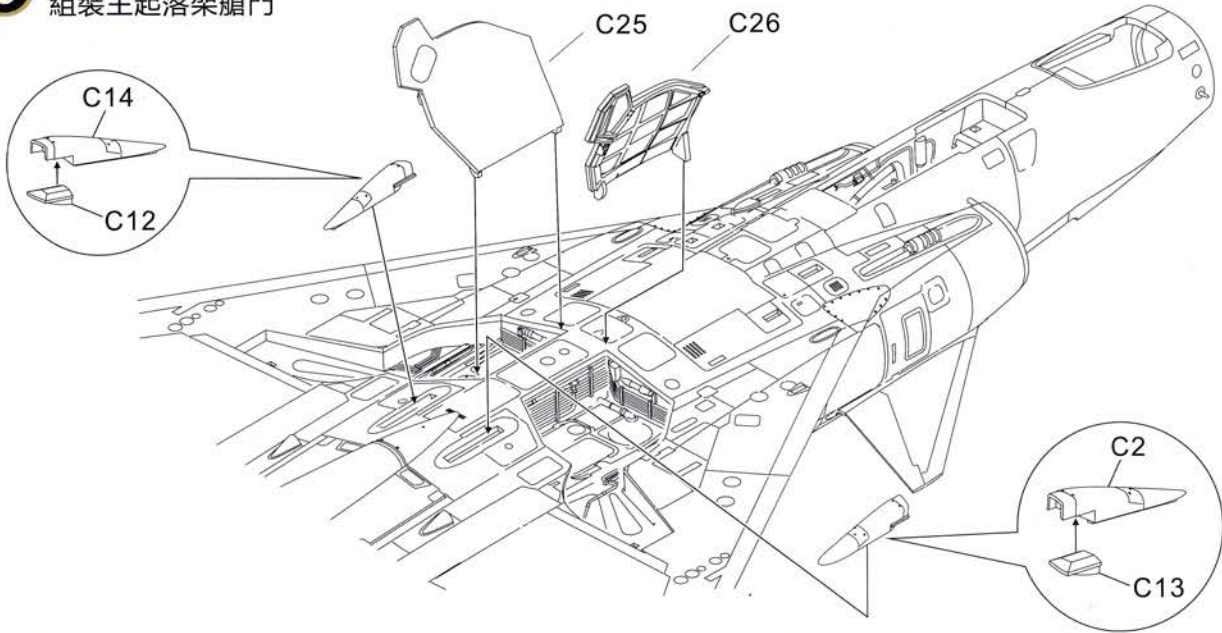

6 Attaching Main Landing Gear
組裝主起落架

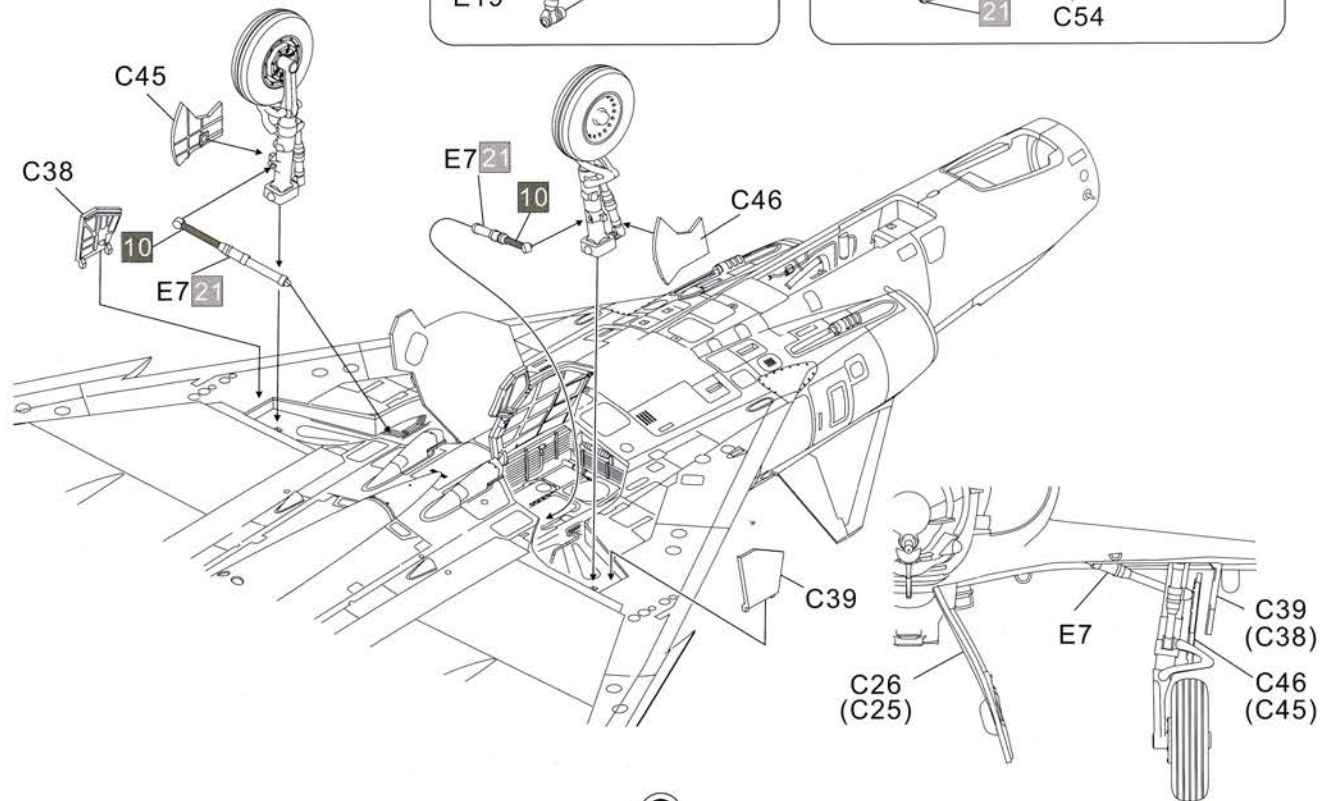
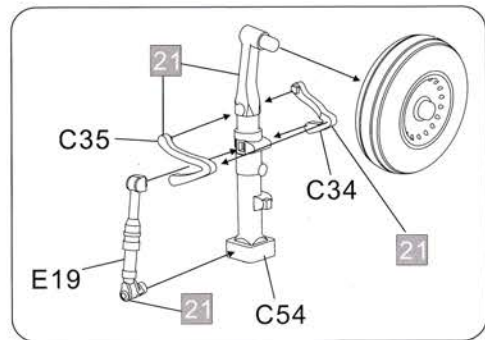
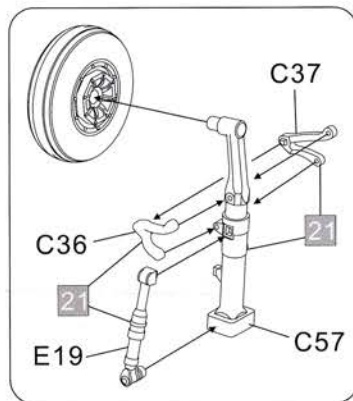
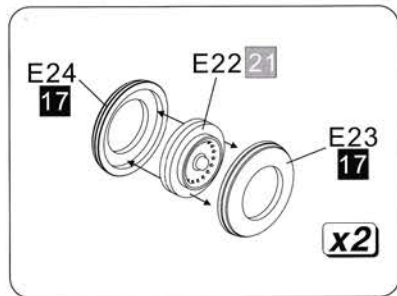

7 Attaching Nose Landing Gear

組裝前起落架

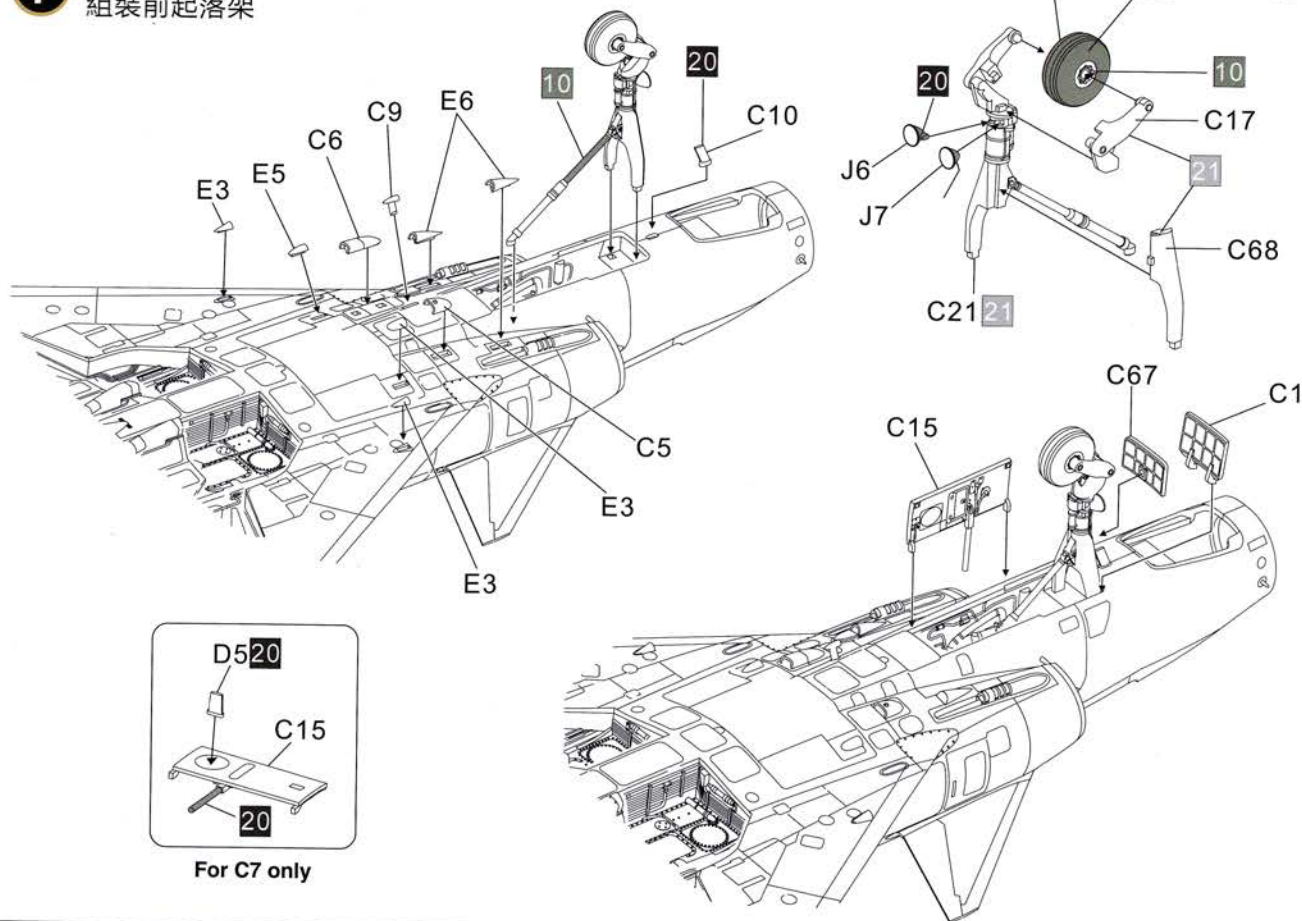

8 Attaching Nose

組裝機頭

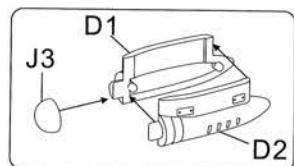

Pave Penny laser designator

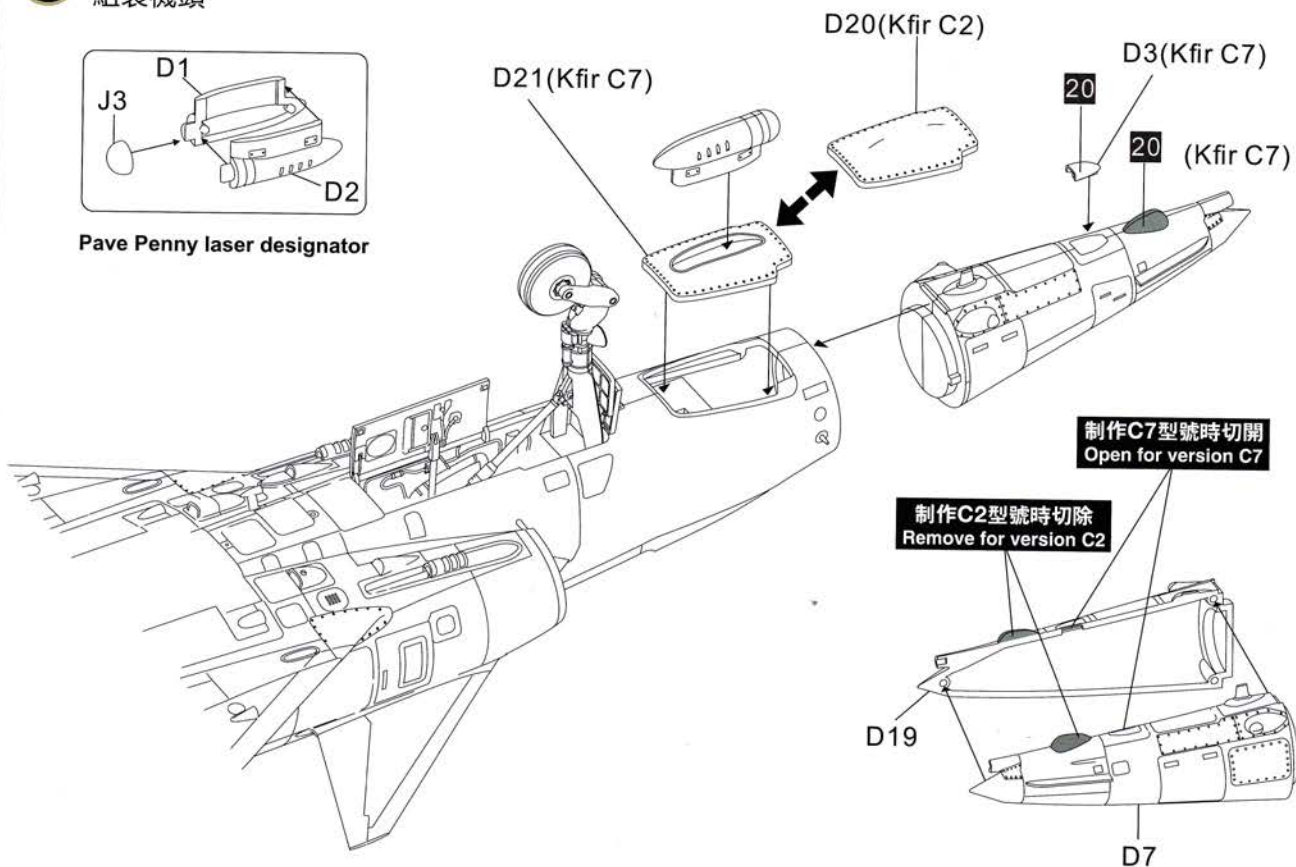

9 Attaching Nozzle
組裝引擎噴口

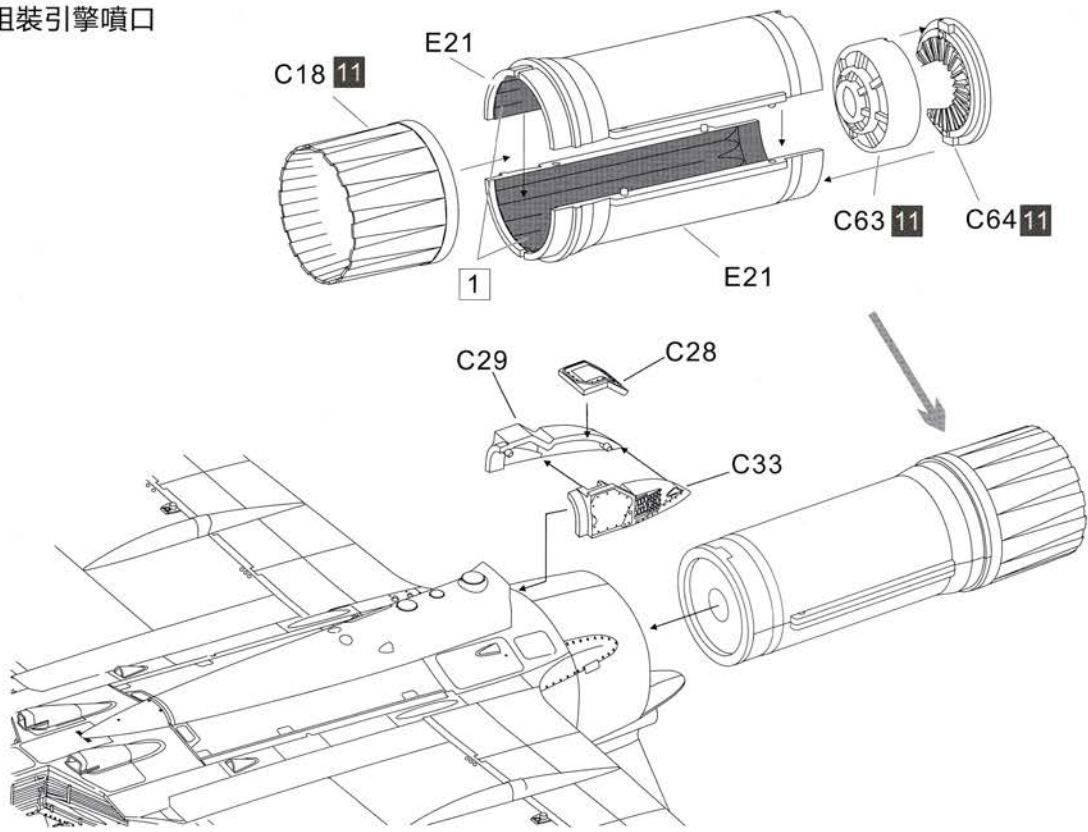

10 Attaching Other Parts
機身小配件

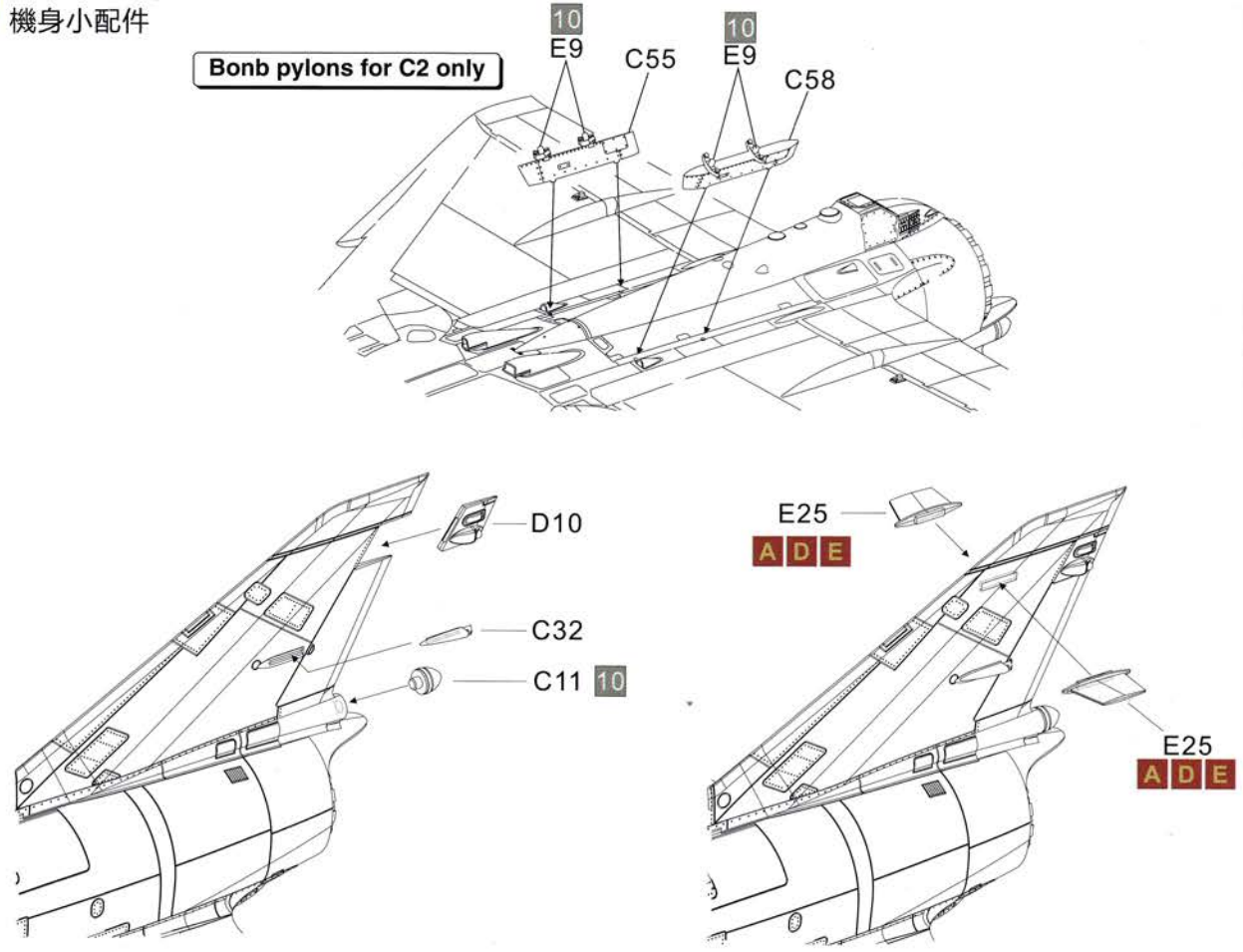

11 C2 Canopy and Ejection Seat
C2 座艙與彈射座椅

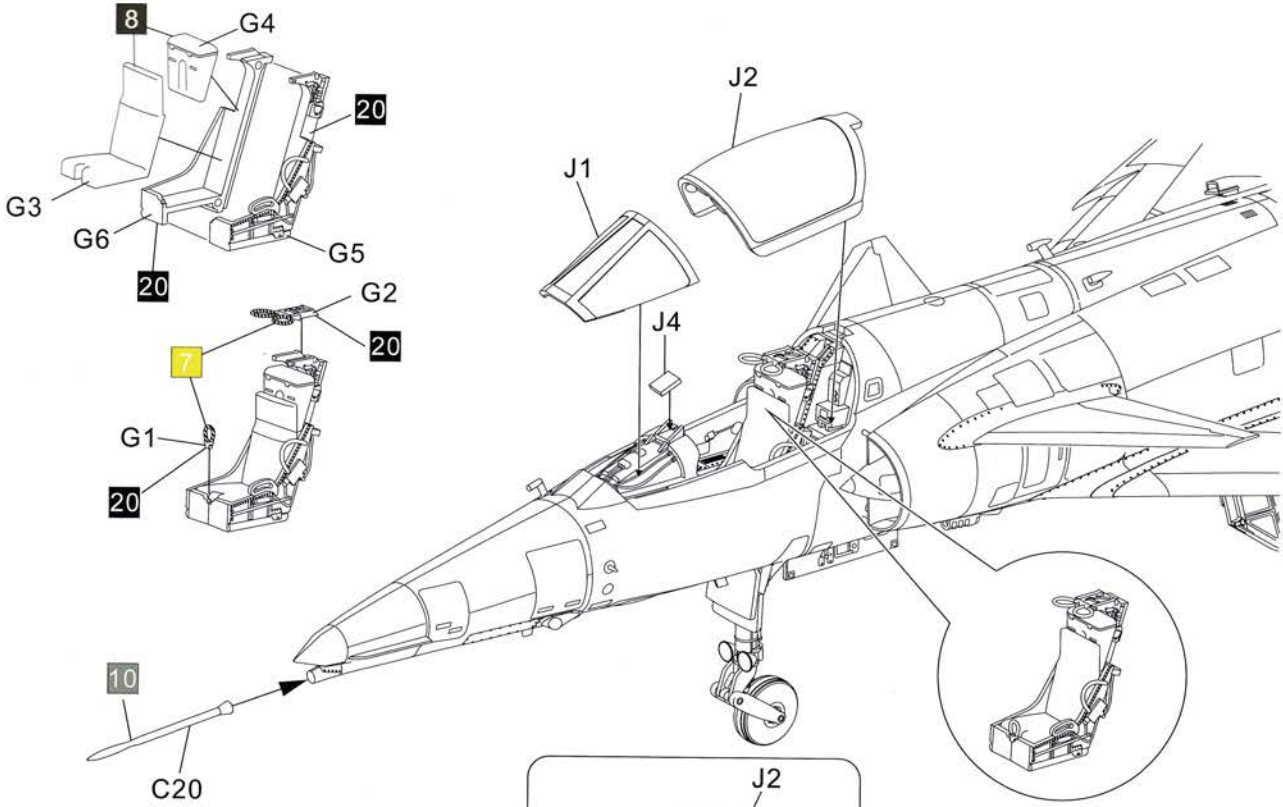

MB JM6 ejection seat

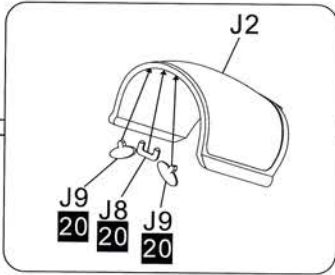

12 C7 Canopy and Ejection Seat
C7 座艙與彈射座椅

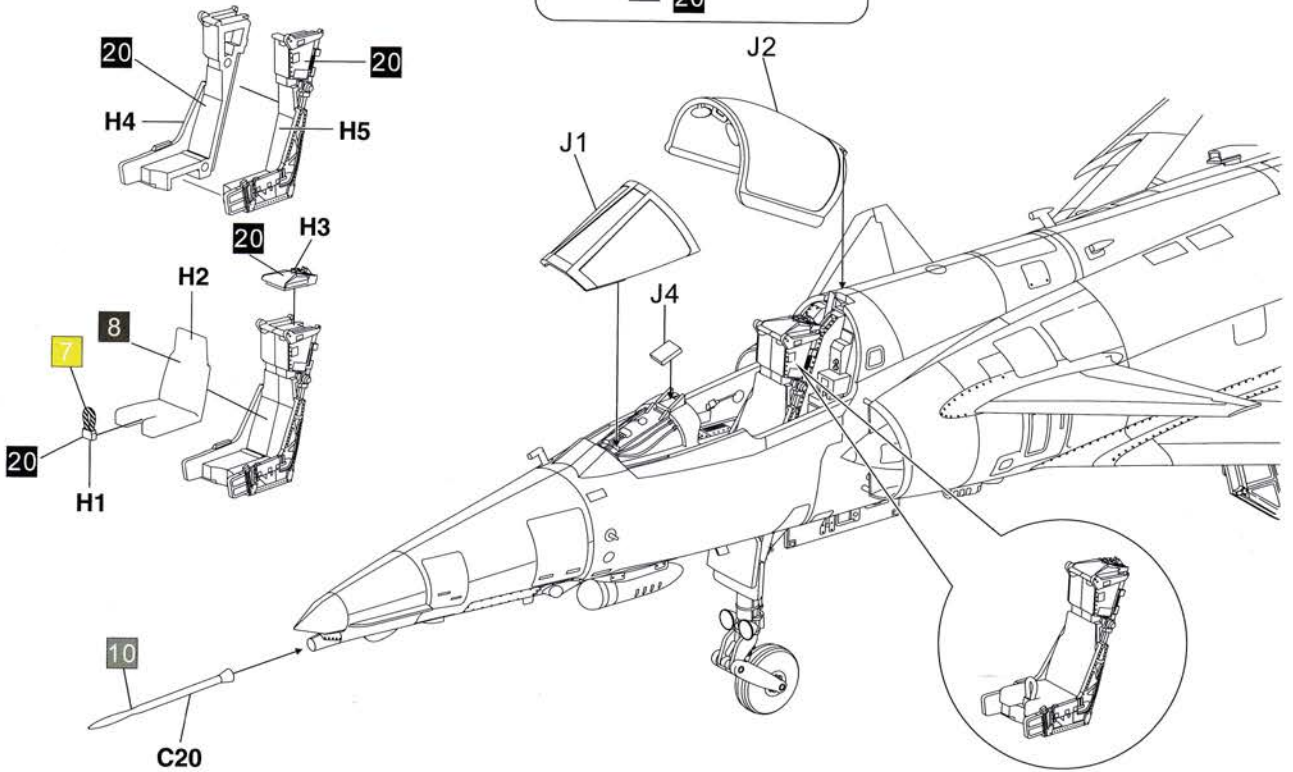

Mk. IN10LH ejection seat

13 Weapons For C2/C7
C2/C7 武器

Python-3 AAM

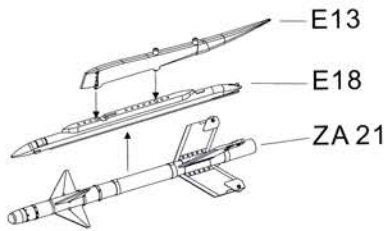

Mk.82 Conical Fin

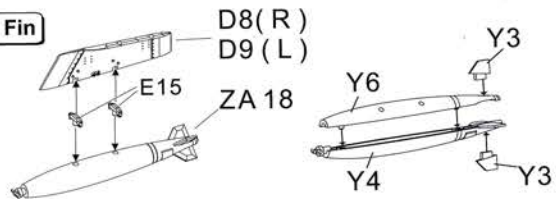

Center line bomb pylon

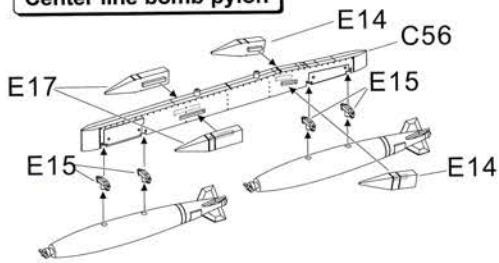

NAPGACH

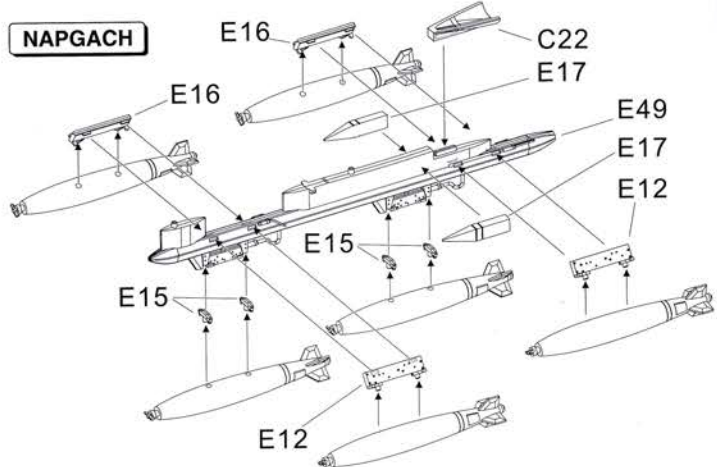

Wing pylon with TER

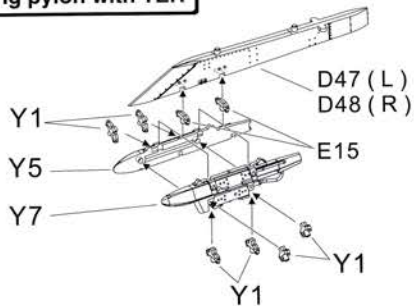

GBU-12

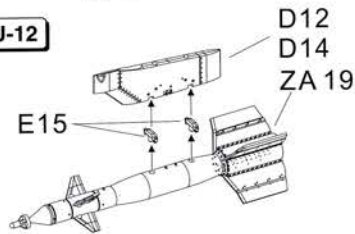

Center line supersonic fuel tank

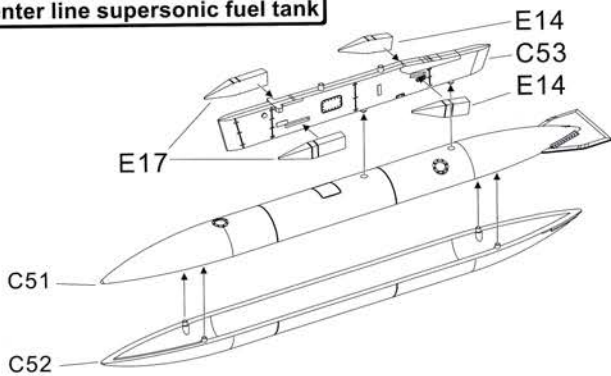

GRIFFIN

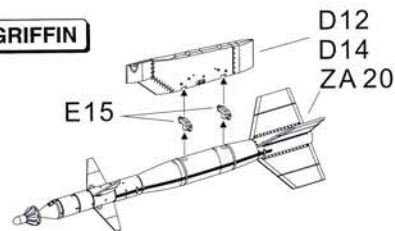

Subsonic fuel tank

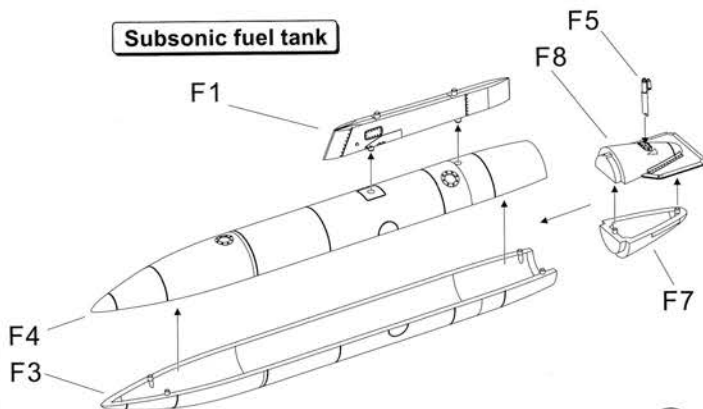

SAIP-Pod

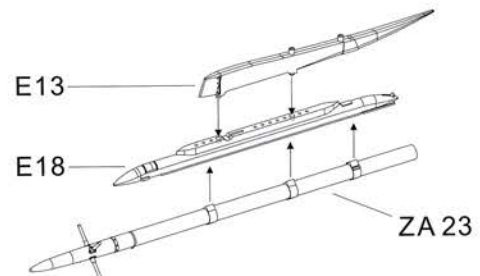

AN/ALQ 167

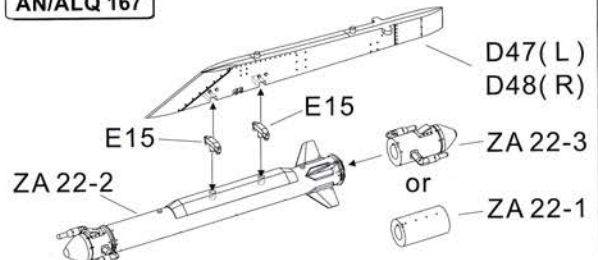

14 C2 External Weapon Configuration(s)
C2 武器外掛裝配展示

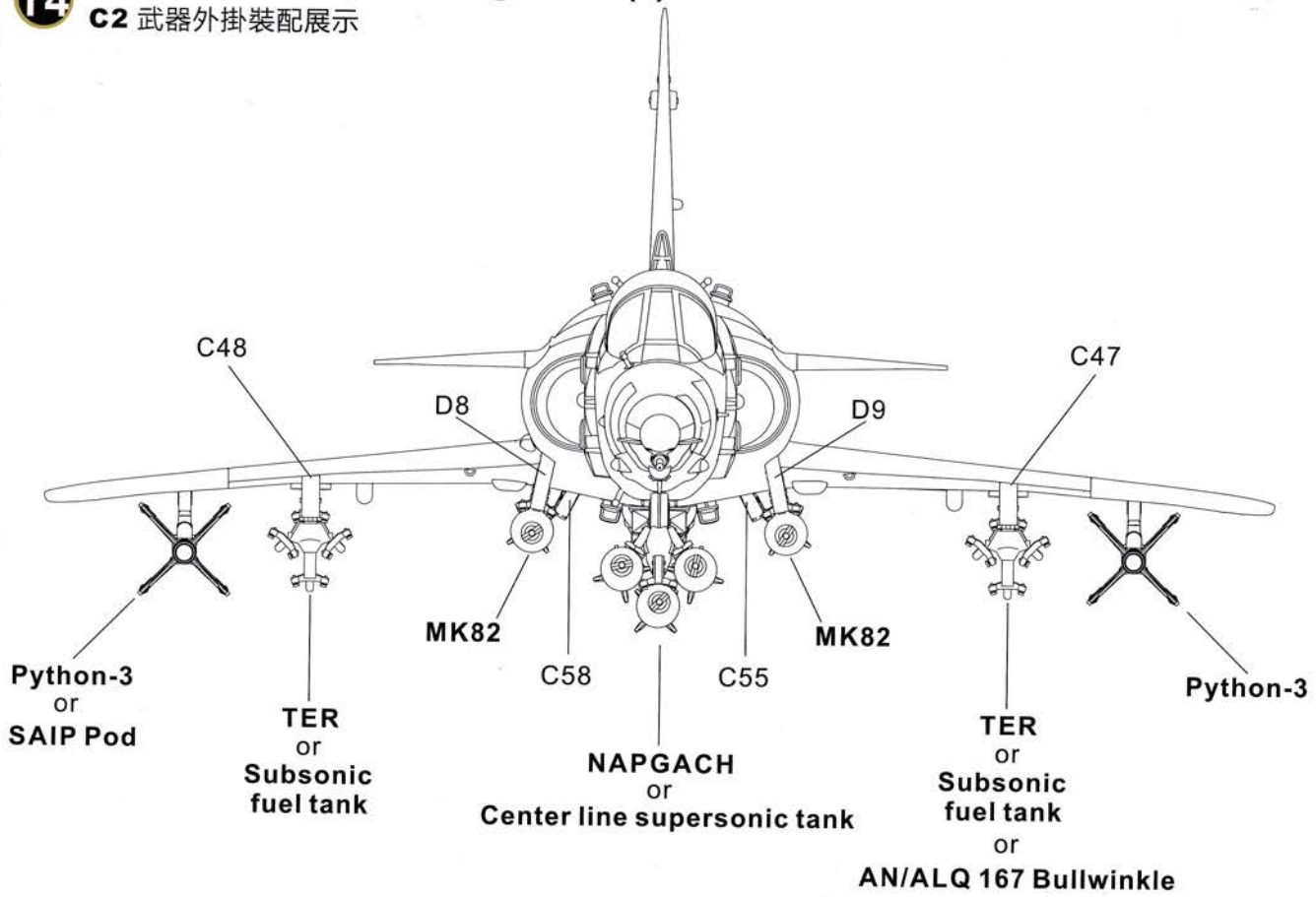

15 C7 External Weapon Configuration(s)
C7 武器外掛裝配展示

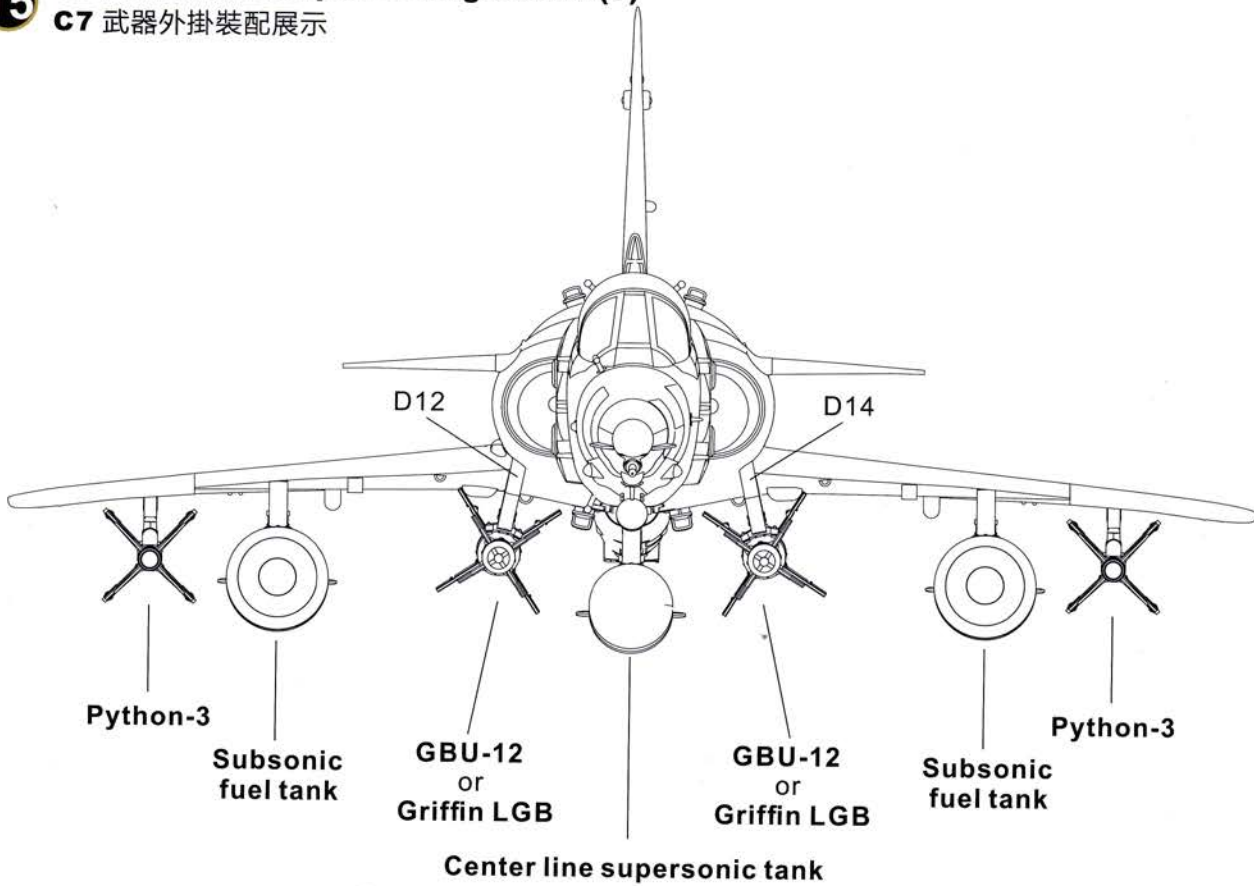

PARTS

A PARTS X 1
88A001-02

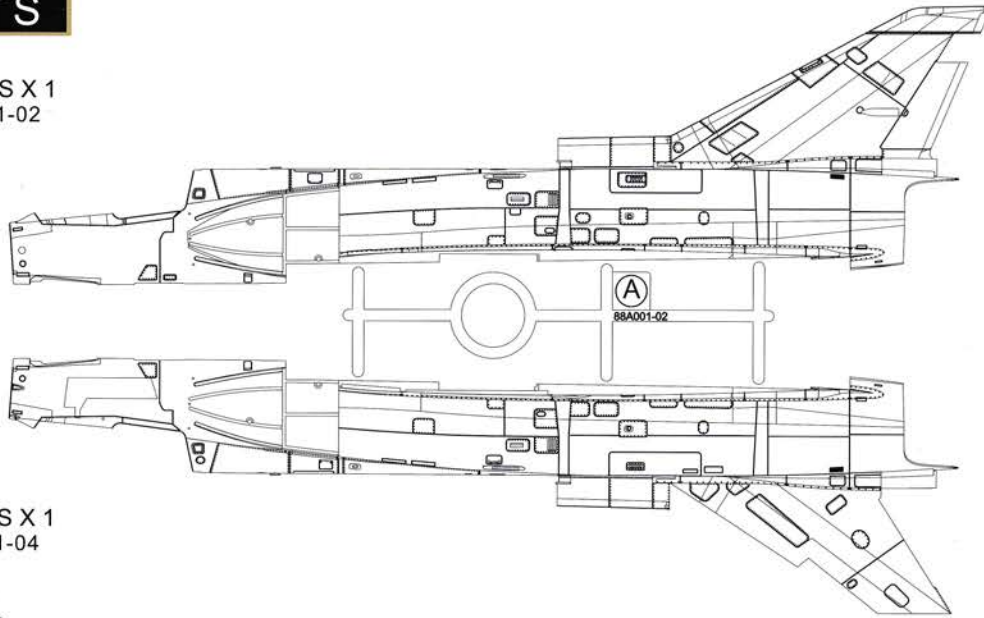

B PARTS X 1
88A001-04

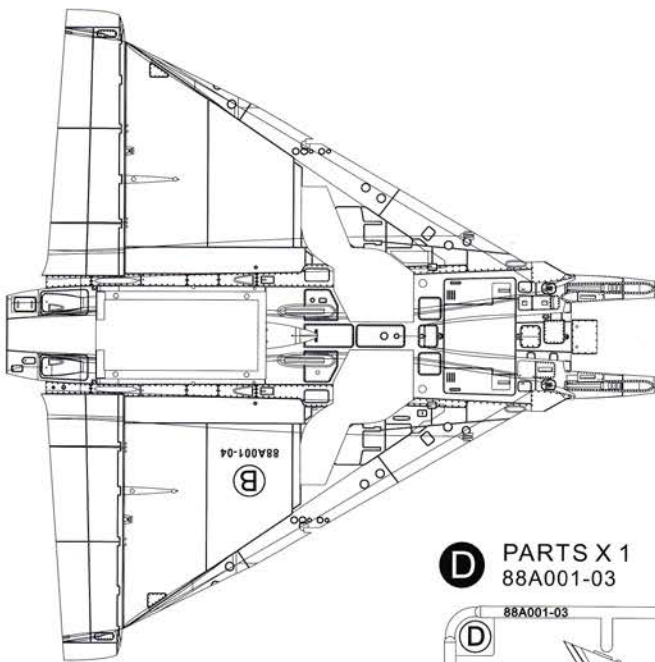

G PARTS X 1
88A001-07

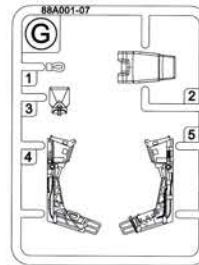

H PARTS X 1
88A001-08

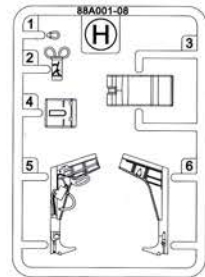

D PARTS X 1
88A001-03

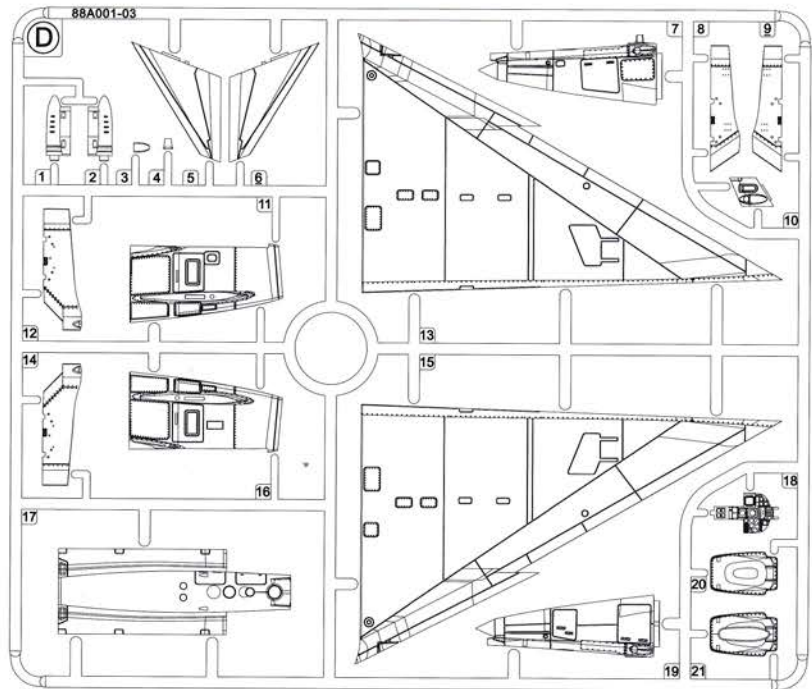

E PARTS X 2
88A001-05

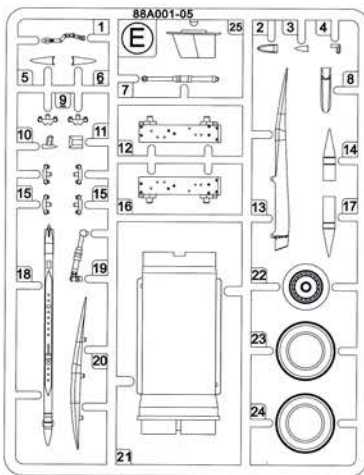

C PARTS X 1
88A001-10

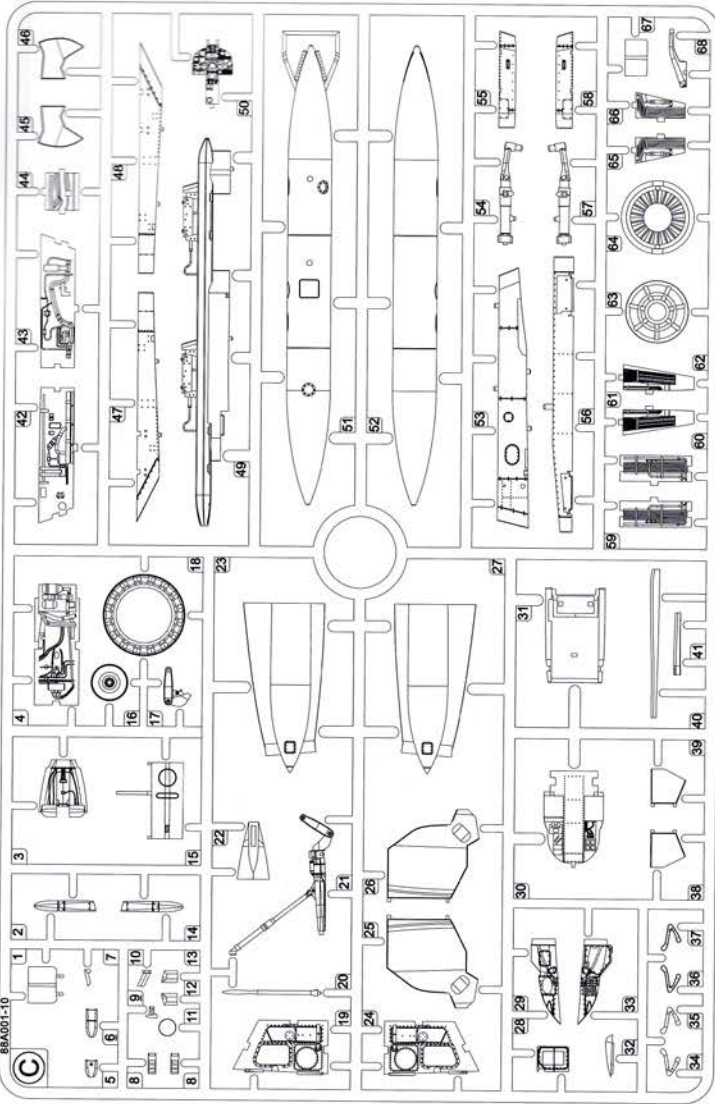

J PARTS X 1
88A001-09

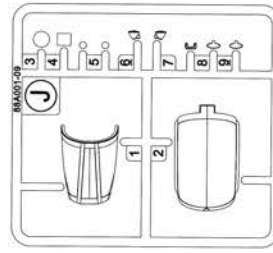

F PARTS X 1
88A001-06

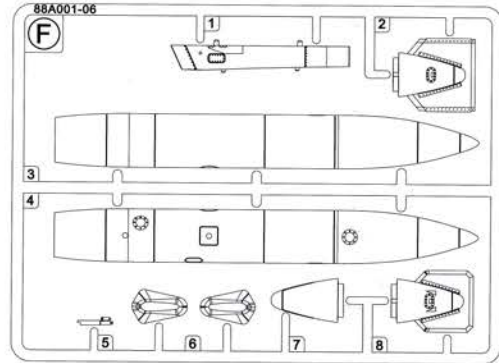

Y PARTS X 2
67020/A80801-05

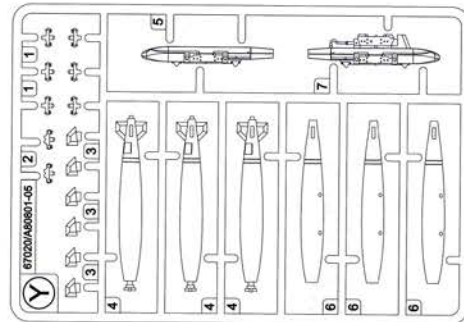

ZA 18 PARTS X 6
99618

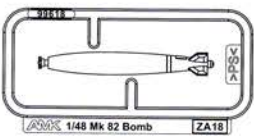

ZA 19 PARTS X 4
99619

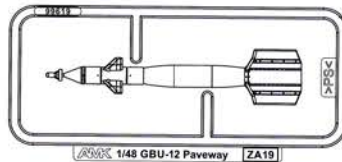

ZA 20 PARTS X 4
99620

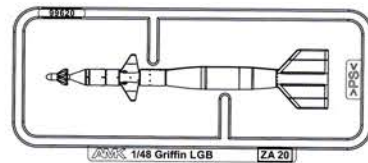

ZA 21 PARTS X 4
99621

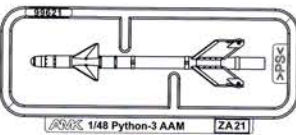

ZA 22 PARTS X 1
99622

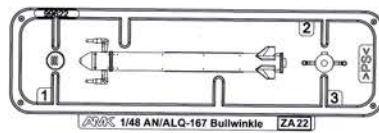

ZA 23 PARTS X 1
99623

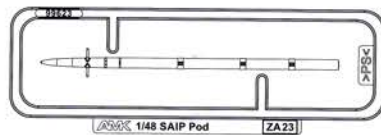



AvantGarde Model Kits (AMK) Co., Ltd.

www.amkhobby.com

 AvantGardeModelKits



MADE IN CHINA

© Copyright 2017, AMK

ISRAEL
IAI Kfir C2/C7

1/48 SCALE

88001-A