

Without question, the rugged B-17 "Flying Fortress" became a symbol of the Second World War. Tasked with the mission of long-range strategic bombing, eight Air Force crews found the daily missions to be dangerous and deadly. Flying tight formations, the lumbering B-17's proved to be easy targets for attacking Luftwaffe fighters. Even though the Flying Fortresses achieved their name by being armed with 11 machine guns in flexible mounts and rotating turrets, the big bombers were vulnerable to frontal attack. Swarms of FW-190 and ME-109 Luftwaffe fighters exploited this deficiency with the resultant loss of countless crews and aircraft. Many bomb groups fitted additional firepower in the clear nose fairing, and the need for added armament lead to the development of the chin turret that was fitted to late "F" model and all "G" model B-17's.

This highly-detailed replica is modeled in 1/48th scale, and depicts a B-17F Flying Fortress armed with field-

mounted, forward machine guns. This variant included many improvements over the B-17E including a one-piece, clear nose, uprated engines, and new propellers. The gross weight of the aircraft totaled 72,000 pounds, and the broad wings spanned a distance of 103 feet 9 inches. The famed B-17F was produced from May of 1942 through September of 1943 with a total of 3405 aircraft built. It was powered by four Curtiss-Wright R-1820 radial engines that produced in excess of 1200 horsepower each. The aircraft was capable of a maximum speed of 288 miles per hour and it could deliver a 4000 pound payload over a range of 2000 miles.

The Revell model of the Boeing B-17F captures the majestic beauty of this famed bomber. It has a detailed cockpit, rotating props, and complete landing gear. It is armed with two external bombs suspended from underwing racks. Markings are provided for the "Memphis Belle", a legendary B-17F that has survived the war to this day.

READ THIS BEFORE YOU BEGIN

- Study the assembly drawings.
- Each plastic part is identified by a number.
- Check the fit of each piece before cementing in place.
- Do not use too much cement to join parts.
- Use only cement for polystyrene plastic.
- Model may be painted to match photos on box.
- Allow paint to dry thoroughly before handling parts.
- Scrape paint from areas to be cemented.
- For better paint and decal adhesion, wash the plastic parts in a mild detergent solution. Rinse and let air dry.

LISEZ CE QUI SUIT AVANT DE COMMENCER LE MONTAGE

- Etudier les schémas d'assemblage.
- Chaque pièce plastique porte un numéro d'identification.
- Contrôler que chaque pièce soit bien conforme avant de la coller à sa place.
- N'utilisez pas trop de colle pour réunir les pièces.
- Utilisez uniquement une colle spéciale pour polystyrène.
- Le modèle peut être peint conformément aux photos sur la boîte.

- Laissez sécher la peinture complètement, avant de manipuler les pièces.
- Grattez la peinture sur les surfaces devant être collées.
- Pour assurer la meilleure adhésion possible de la peinture et des décalcomanies, laver les pièces de plastique avec une légère solution savonneuse. Rincer et laisser sécher à l'air.

LEA ESTO ANTES DE EMPEZAR

- Estudie los dibujos de ensamblaje.
- Cada pieza de plástico se identifica por un número.
- Verifique que cada pieza encaje bien antes de pegar en posición.
- No use demasiado pegamento para unir las piezas.
- Use únicamente pegamento para plástico de poliestireno.
- El modelo puede pintarse de acuerdo con las fotografías de la caja.
- Permita que se seque la pintura completamente antes de tocar las piezas.
- Raspe la pintura de las superficies que serán pegadas.
- Para una mejor fijación de la pintura y de las calcomanías, lávese las piezas plásticas en una solución de detergente suave. Enjuaguense y déjense secar al aire.

| A | INTERIOR GREEN | INTERIEUR VERT | INTERIOR VERDE |
|---|----------------|----------------|----------------|
| B | YELLOW | JAUNE | AMARILLO |
| C | ALUMINUM | ALUMINIUM | ALUMINIO |
| D | OLIVE DRAB | VERT OLIVE | ACEITUNADO |
| E | GRAY | GRIS | GRIS |
| F | FLAT BLACK | NOIR TERNE | NEGRO APAGADO |
| G | DARK GREEN | VERT FONCE | VERDE OSCURO |
| H | METALLIC | METALLIC | METALICO |



DECAL (DIP IN WATER)
 DECALCOMANIE (A PLONGER DANS L'EAU)
 DECALCOMANIA (MOJE CON AGUA)



REPEAT SEVERAL TIMES
 A REPETER PLUSIEURS FOIS
 REPITA VARIAS VECES



DO NOT CEMENT
 NE PAS COLLER
 NO USE PEGAMENTO

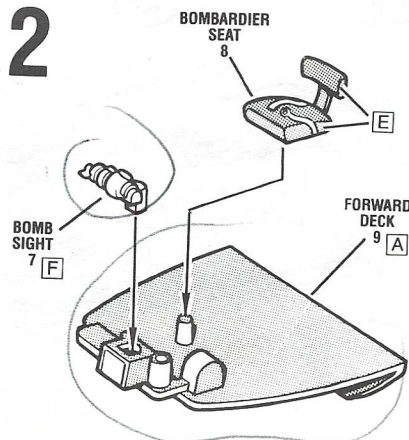
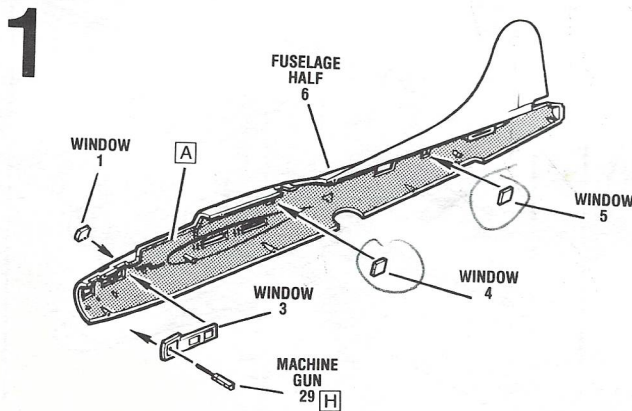

3

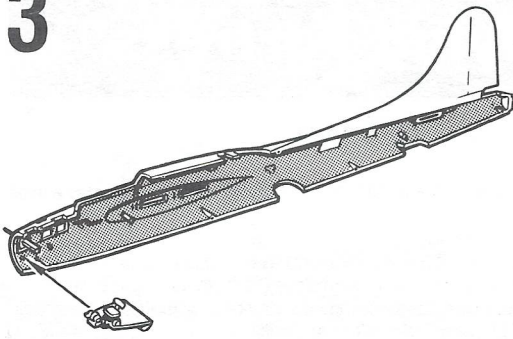

4

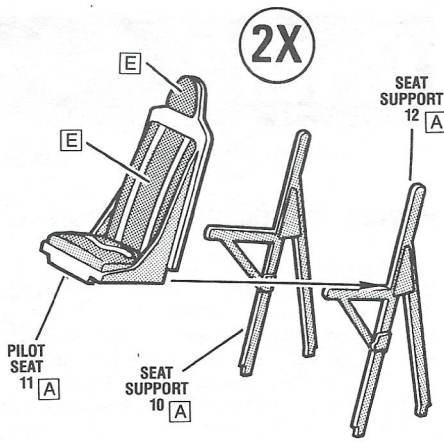

11

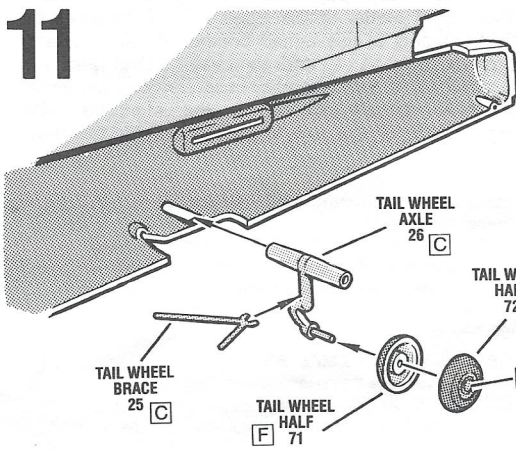

12

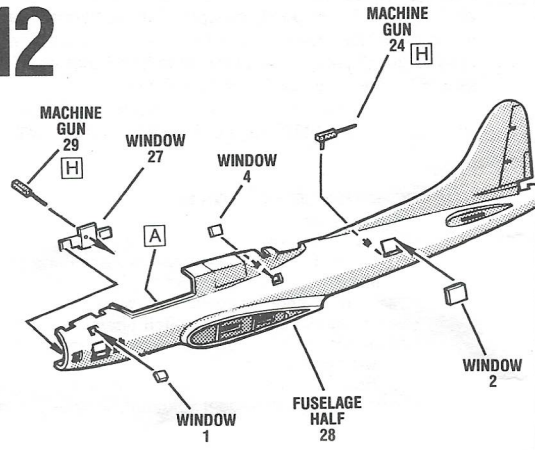

19

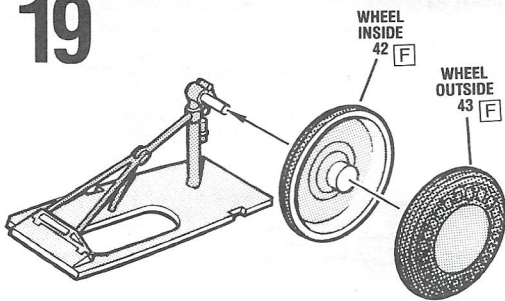

- REPEAT FOR OTHER SIDE
- REPETER POUR L'AUTRE COTE
- REPITASE PARA EL OTRO LADO

20

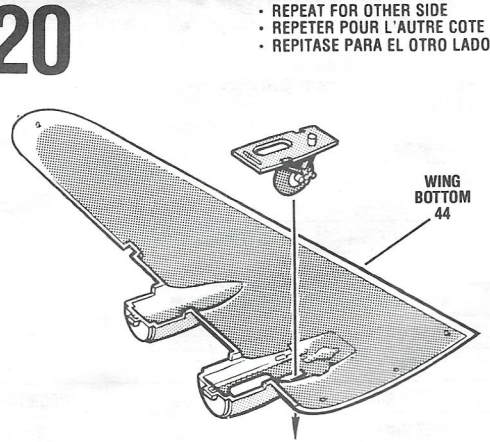

28

(B)

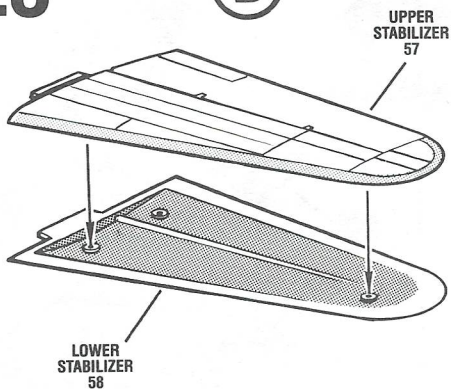

29

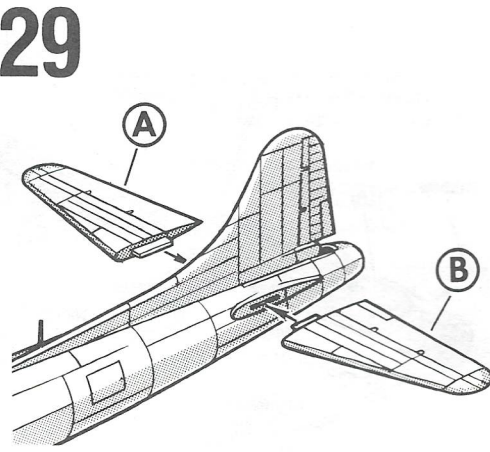

5

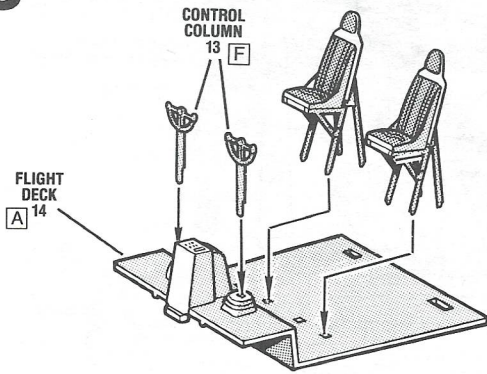

6

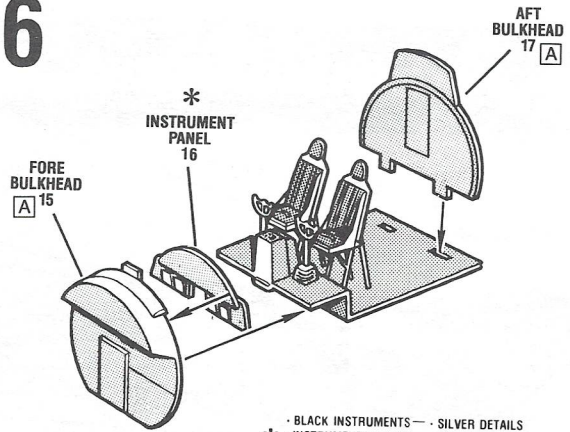

* BLACK INSTRUMENTS — SILVER DETAILS
 * INSTRUMENTS NOIRS — DETAILLES ARGENT
 * INSTRUMENTOS NEGROS — DETALLES PLATEADOS

13

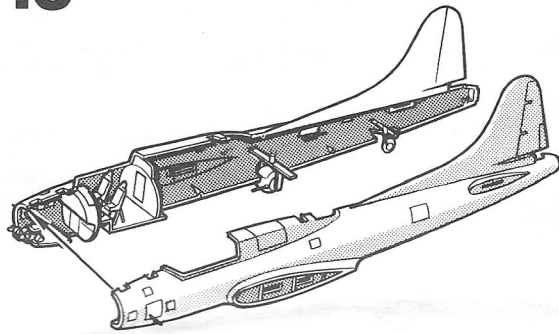

14

• FRAME IS
 FUSELAGE COLOR
 • LES MONTANTS SONT
 DE LA COULEUR
 DU FUSELAGE
 • ARMAZON DEL COLOR
 DEL FUSELAJE

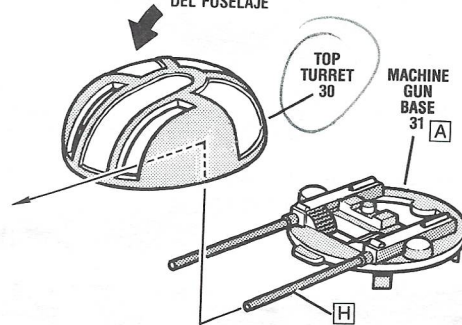

21

• REPEAT FOR OTHER SIDE
 • REPETER POUR L'AUTRE COTE
 • REPITASE PARA EL OTRO LADO

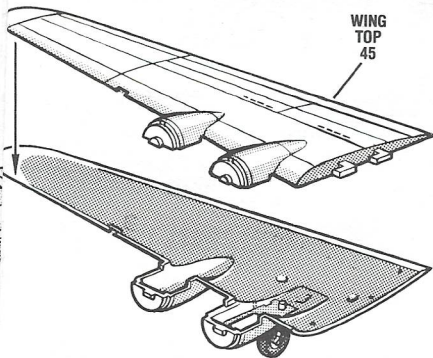

22 (4X)

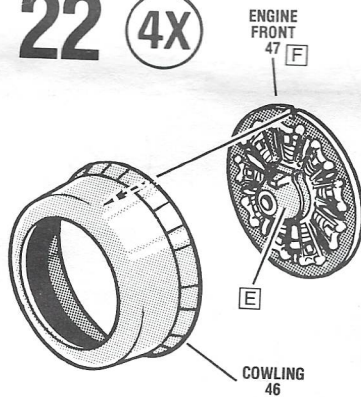

23 (4X)

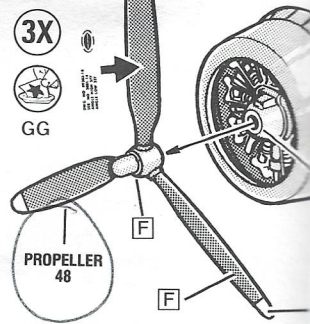

30

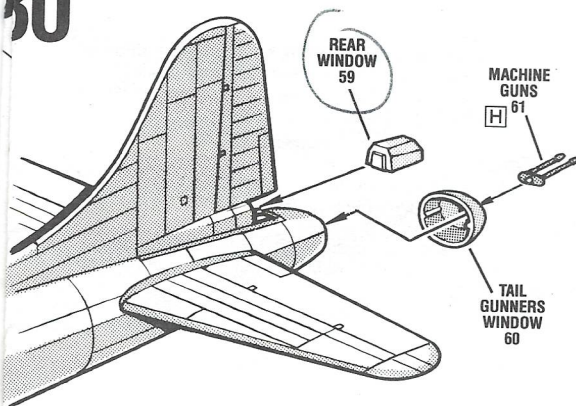

31 (2X)

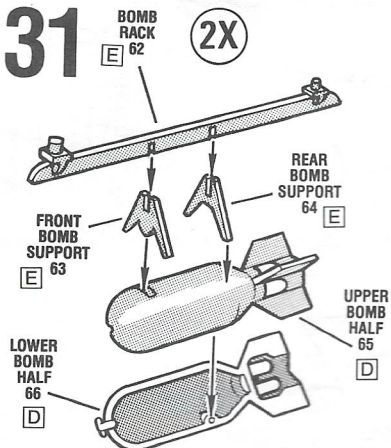

32

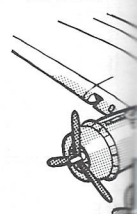

7

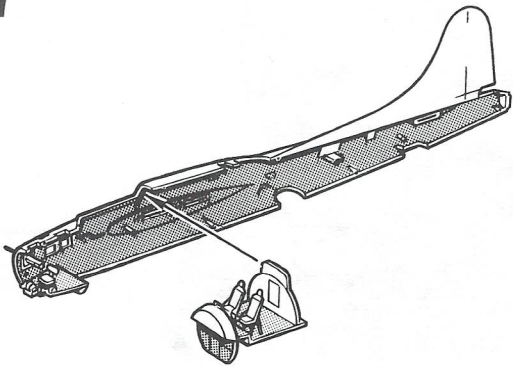

8

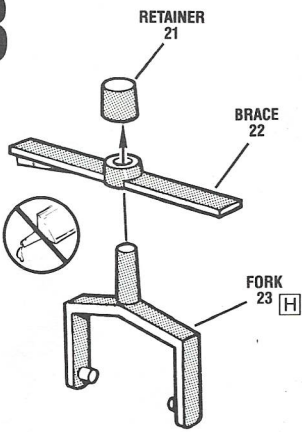

9

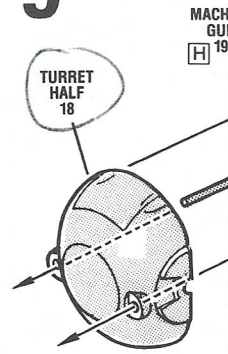

MACH
GUN
19

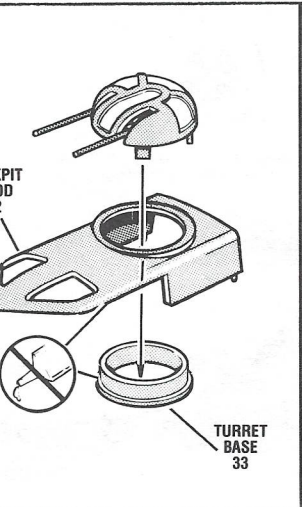

15

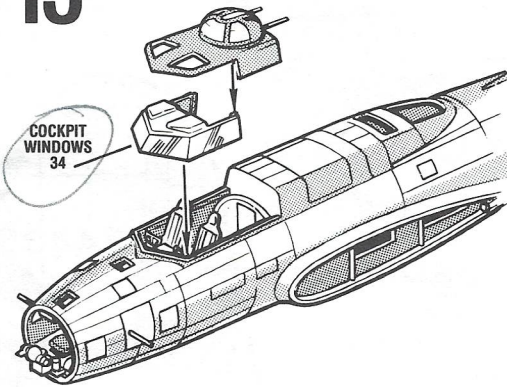

16

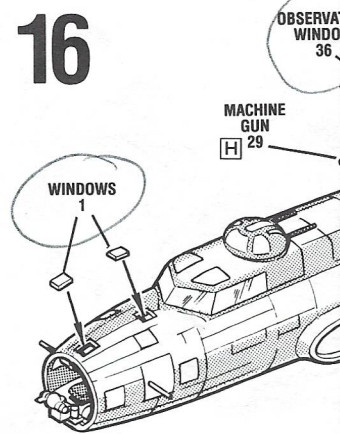

OBSERVA
WINDO
36

MACHINE
GUN
29

24

- REPEAT FOR OTHER SIDE
- REPETER POUR L'AUTRE COTE
- REPITASE PARA EL OTRO LADO

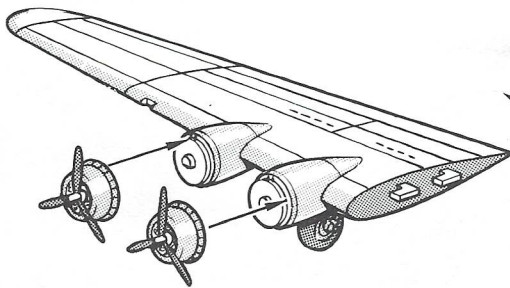

25

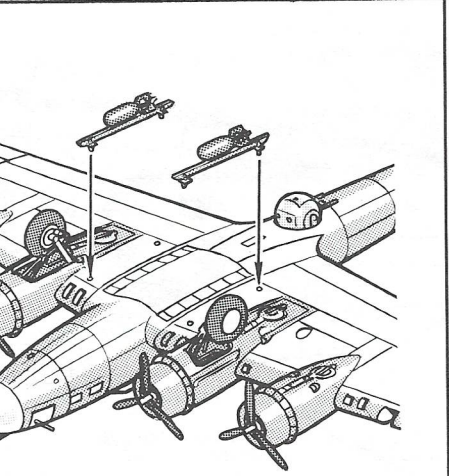
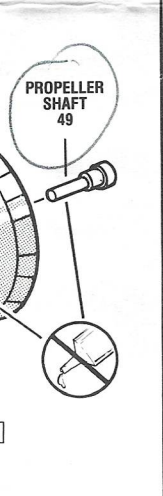
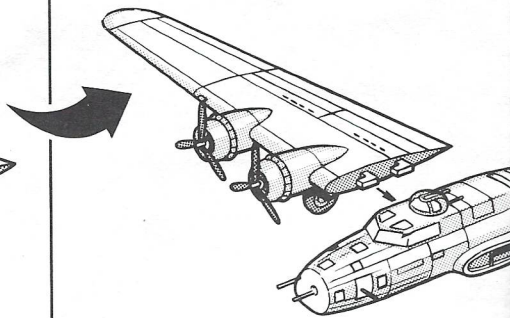

33

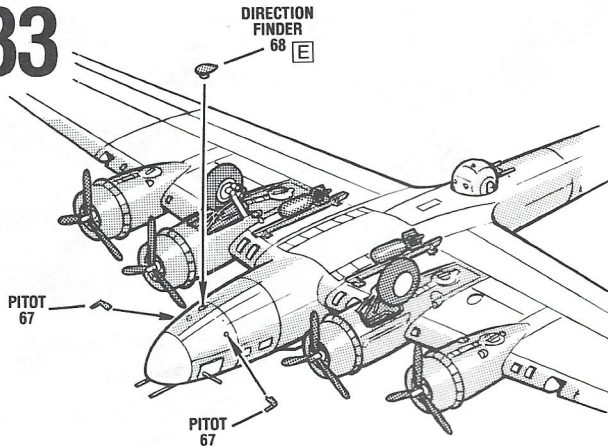

33

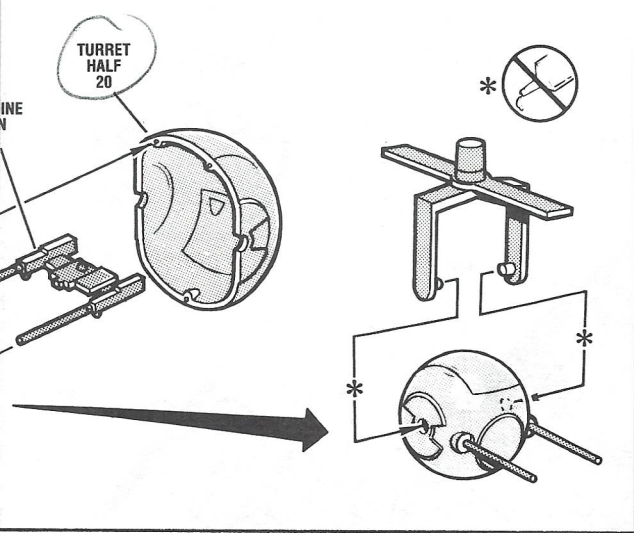

10

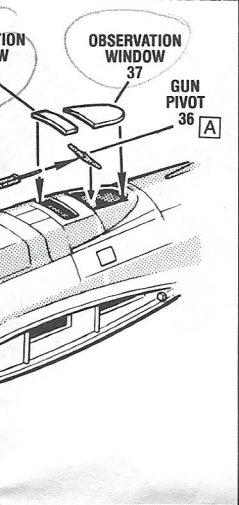
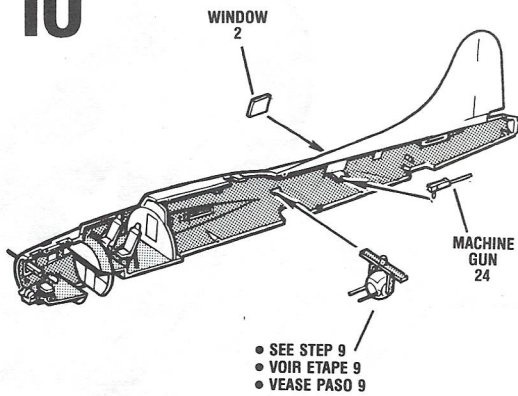

17

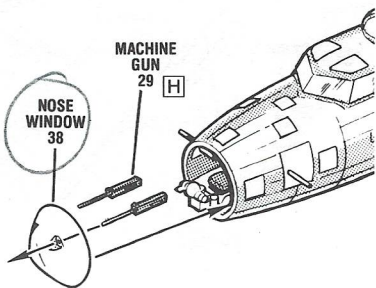

18

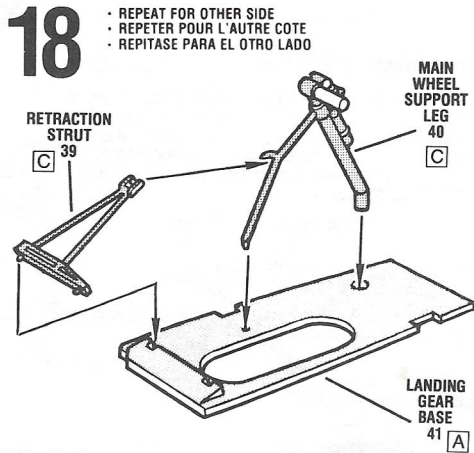

26

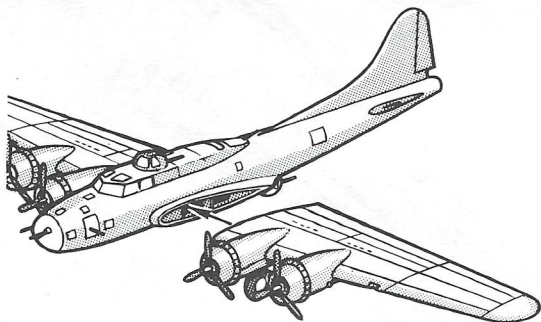

27

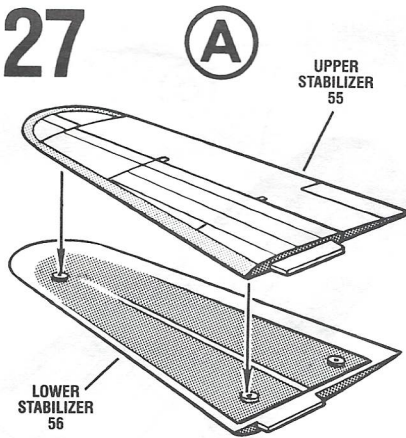

34

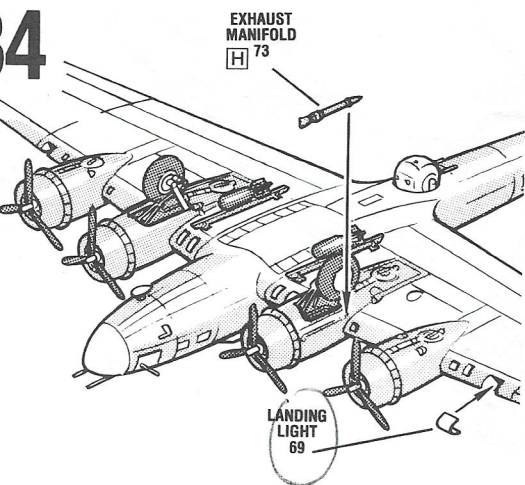

35

