

PLASTIC PARTS

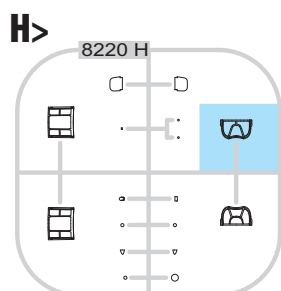
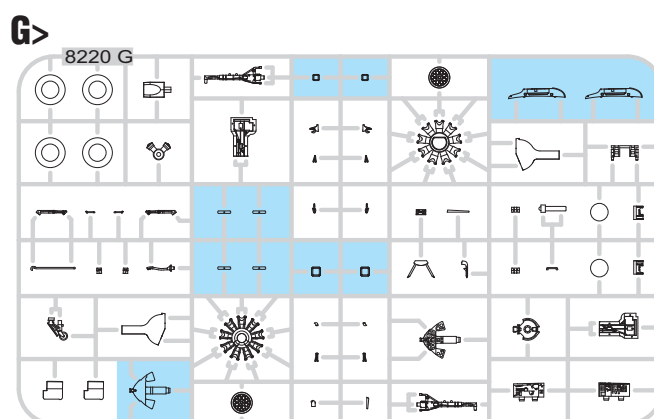
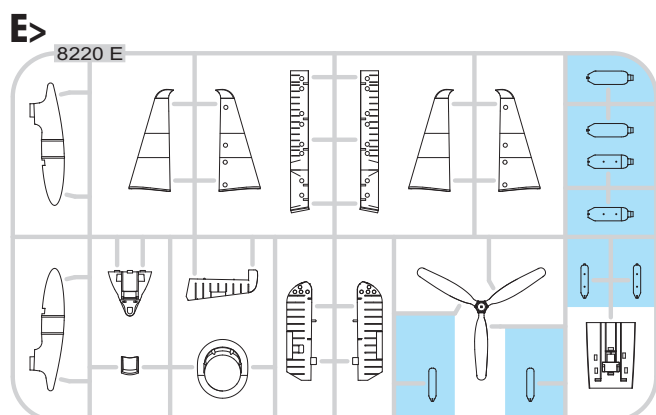
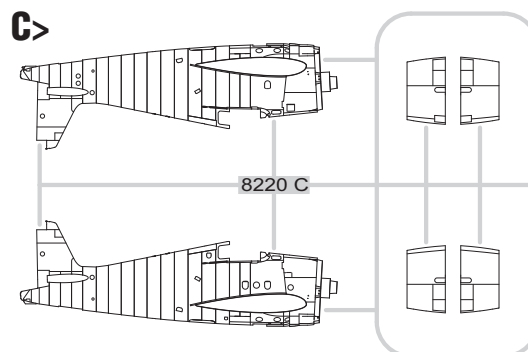
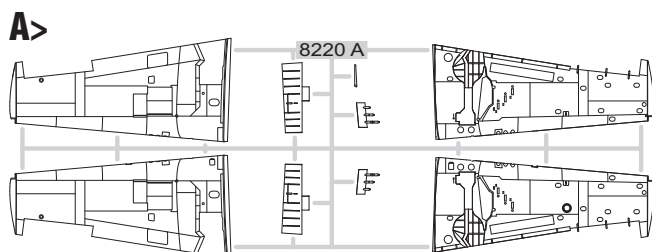

GUNZE		
H4	C4	RED
H11	C62	FLAT WHITE
H12	C33	FLAT BLACK
H47	C41	RED BROWN
H52	C12	OLIVE DRAB
H58	C351	INTERIOR GREEN
H74	C368	SKY
H76	C61	BURNT IRON
H77	C137	TIRE BLACK
H90	C47	CLEAR RED

GUNZE		
H91	C48	CLEAR YELLOW
H94	C138	CLEAR GREEN
H305	C305	GRAY
H306	C306	GRAY
H327	C327	RED
Mr. METAL COLOR		
MC213		STAINLESS
MC214		DARK IRON
MC218		ALUMINIUM

ATTENTION



UPOZORNĚNÍ



ACHTUNG



ATTENTION

(GB)

Carefully read instruction sheet before assembling. When you use glue or paint, do not use near open flame and use in well ventilated room. Keep out of reach of small children. Children must not be allowed to suck any part, or pull vinyl bag over the head.

(CZ)

Před započatím stavby si pečlivě prostudujte stavební návod. Při používání barev a lepidel pracujte v dobře větrané místnosti. Lepidla ani barvy nepoužívejte v blízkosti otevřeného ohně. Model není určen malým dětem, mohlo by dojít k požití drobných dílů.

(D)

Vor dem Zusammenbau die Bauanleitung gut durchlesen. Kleber und Farben nicht in der Nähe von offenem Feuer verwenden und für eine ausreichende Belüftung sorgen. Den Bausatz von kleinen Kindern fernhalten. Vermeiden Sie, dass Kinder Bauteile in den Mund nehmen oder sich Plastiktüten über den Kopf ziehen.

(F)

Lire soigneusement la fiche d'instructions avant d'assembler. Ne pas utiliser de colle ou de peinture à proximité d'une flamme nue, et aérer la pièce de temps en temps. Garder hors de portée des enfants en bas âge. Ne pas laisser les enfants mettre en bouche ou sucer les pièces, ou passer un sachet vinyl sur la tête.

INSTRUCTION SIGNS



INSTR. SYMBOLY



INSTRUKTION SINNBILDEN



SYMBOLES



OPTIONAL
FACULTATIF
NACH BELIEBEN
VOLBA



BEND
PLIER SIL VOUS PLAIT
BITTE BIEGEN
OHNOUT



OPEN HOLE
FAIRE UN TROU
OFFNEN
VYVRTAT OTVOR



SYMETRICAL ASSEMBLY
MONTAGE SYMÉTRIQUE
SYMMETRISCHE AUFBAU
SYMETRICKÁ MONTÁŽ



REVERSE SIDE
OTOČIT



REMOVE
RETIRER
ENTFERNEN
ODŘÍZNOUT

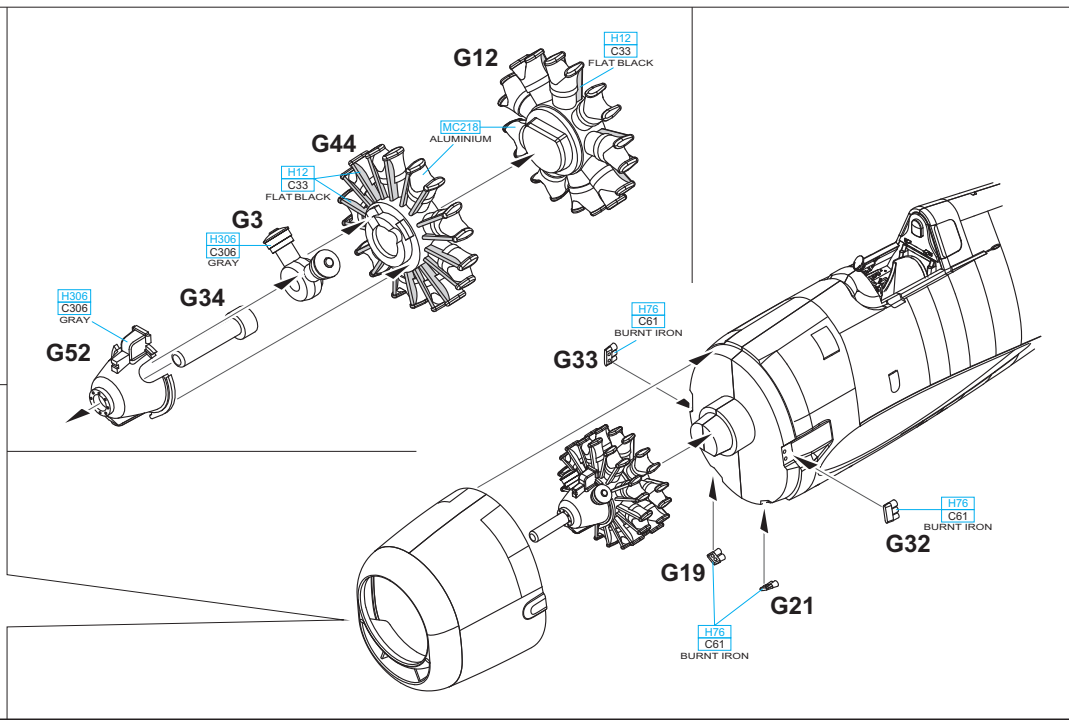
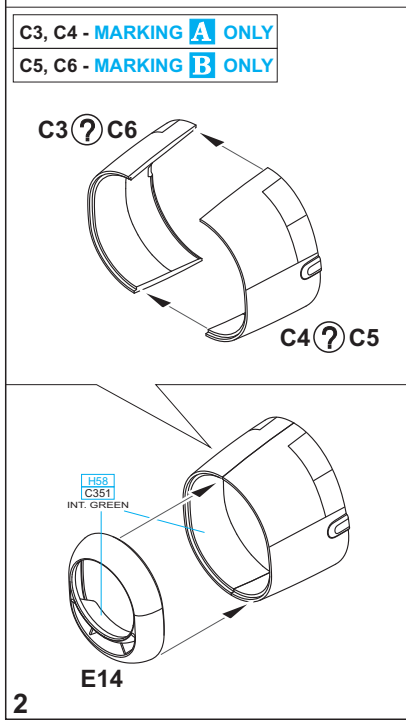
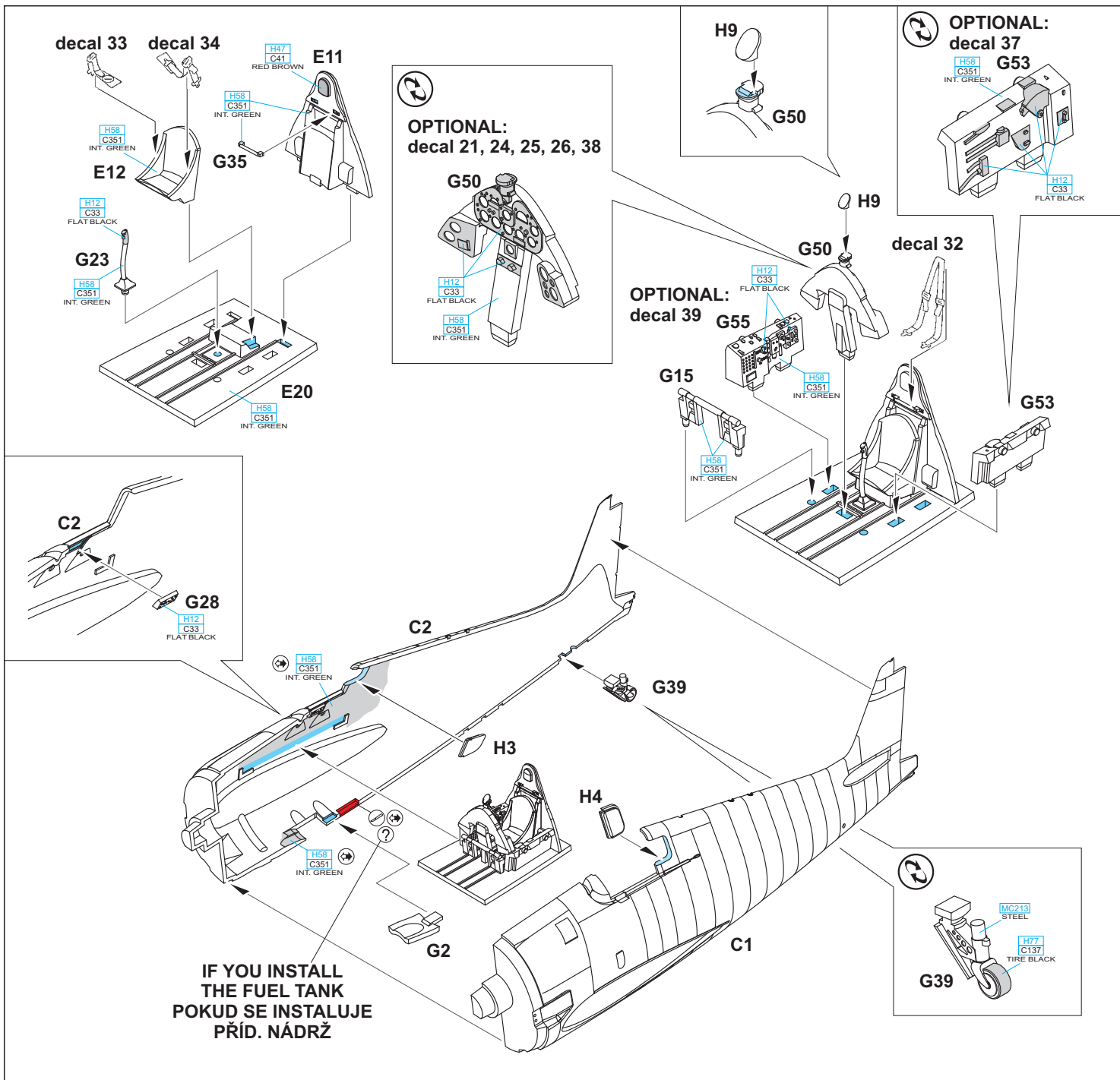

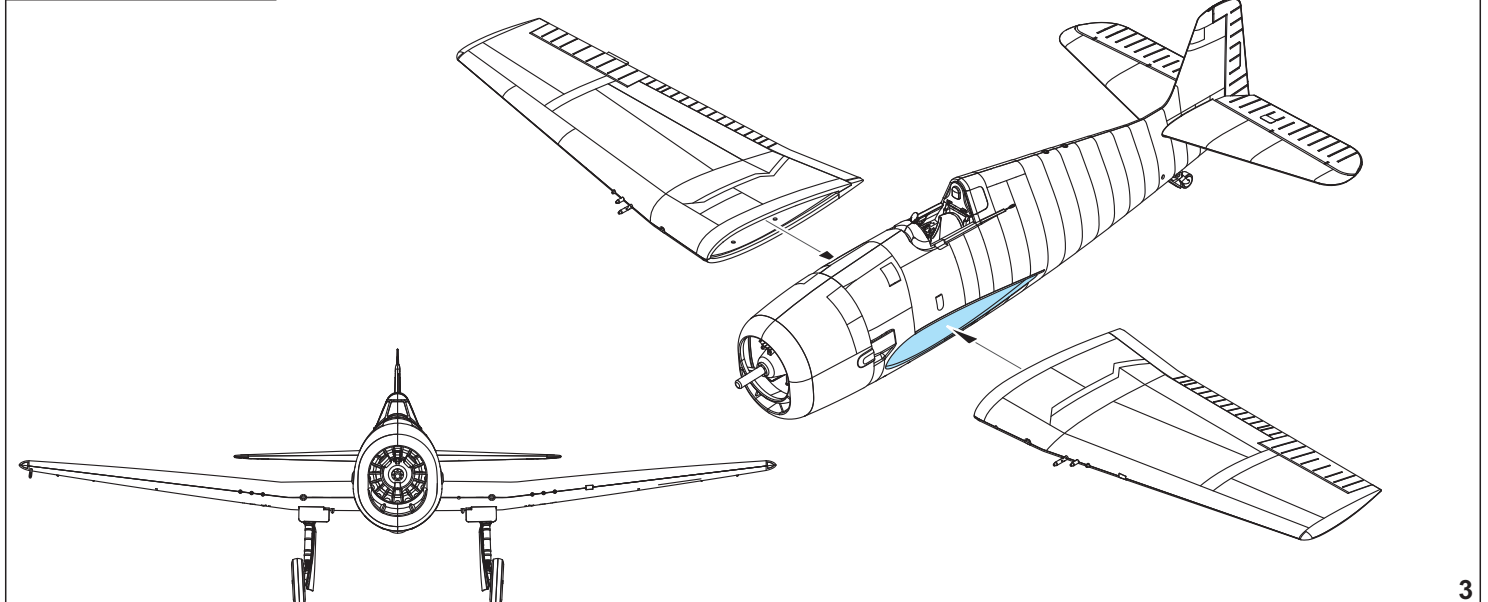
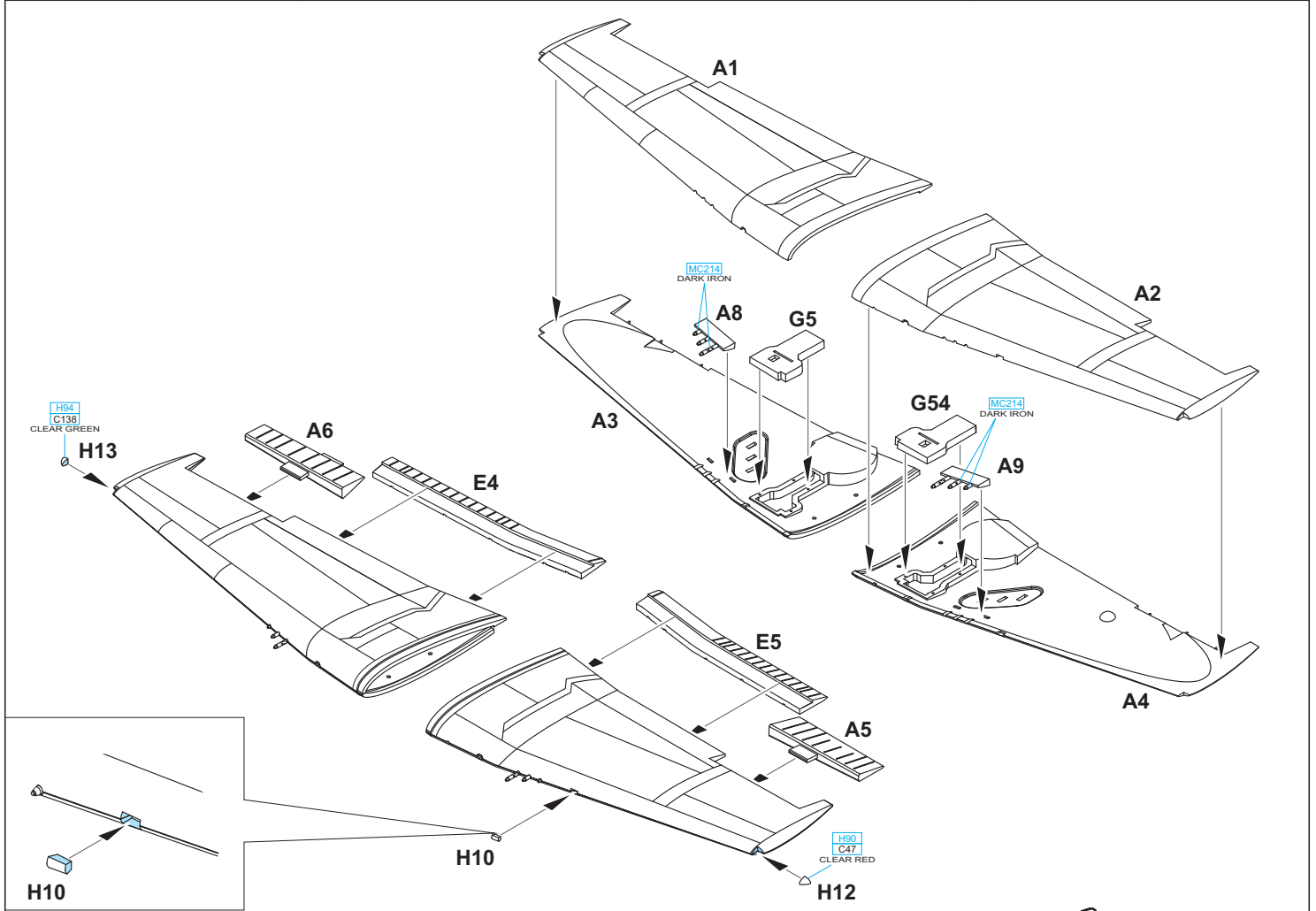
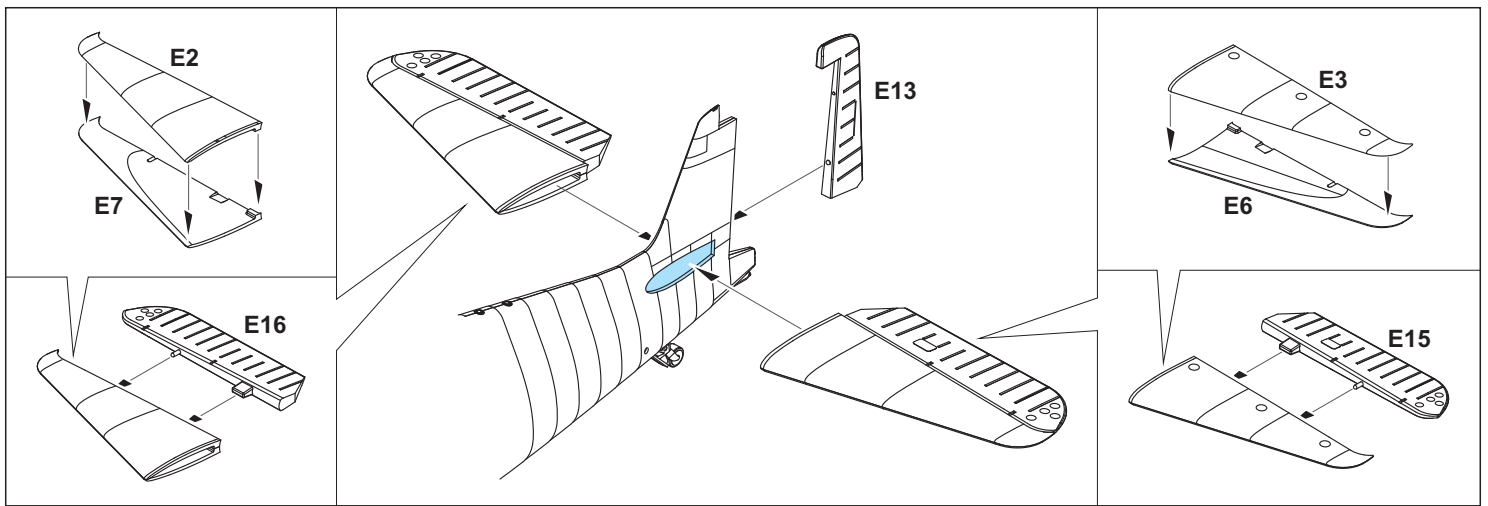

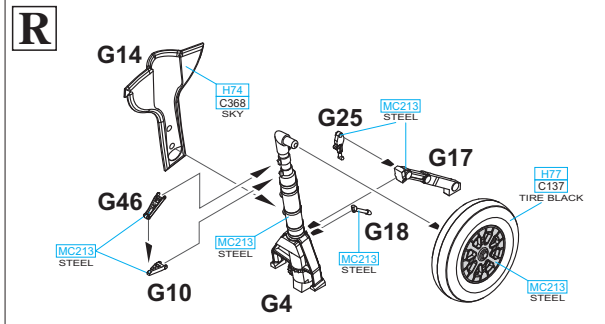
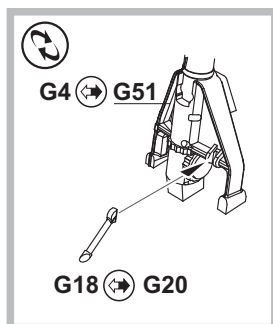
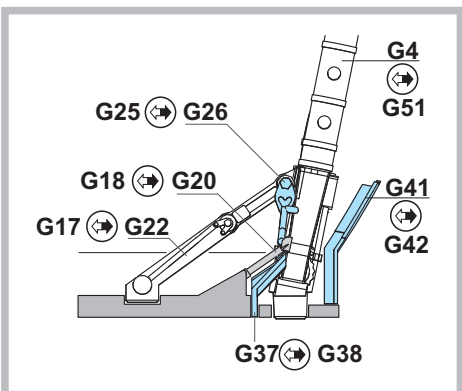
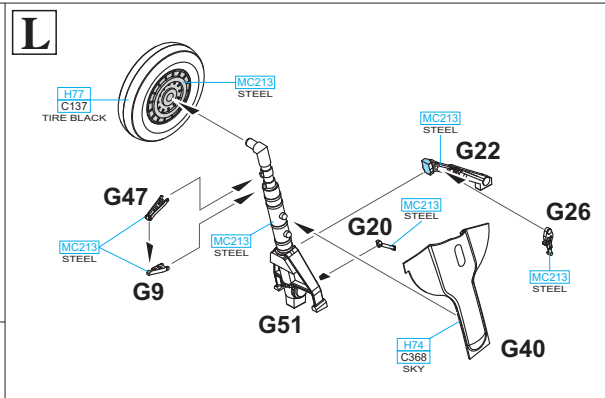
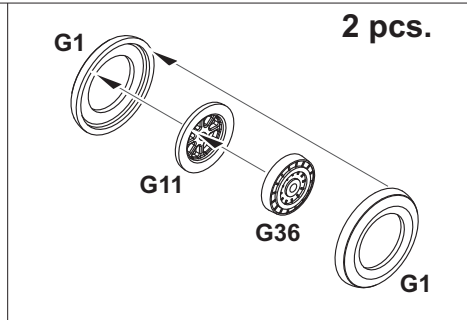
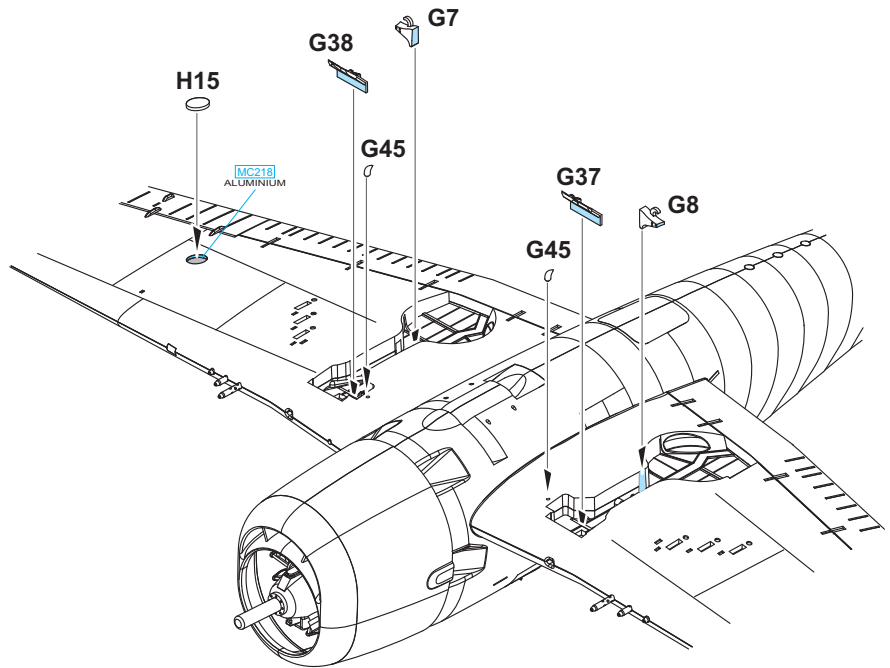
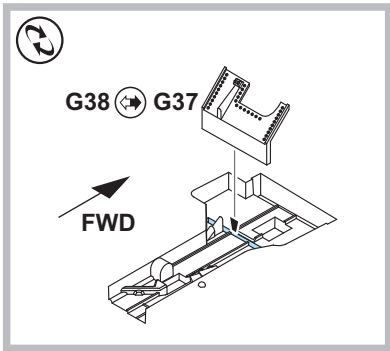
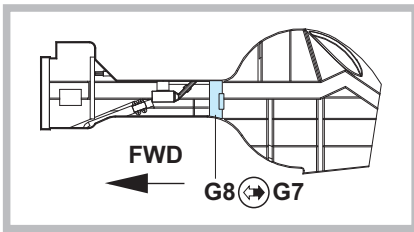
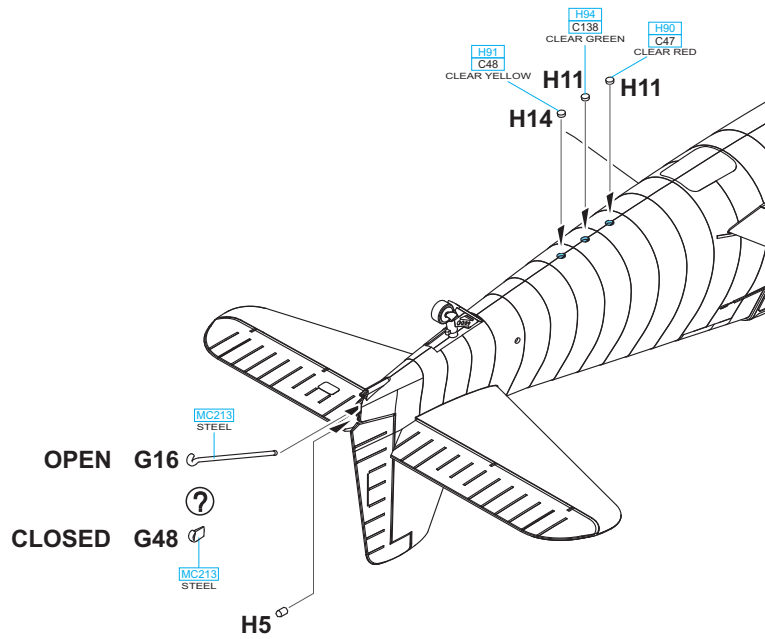

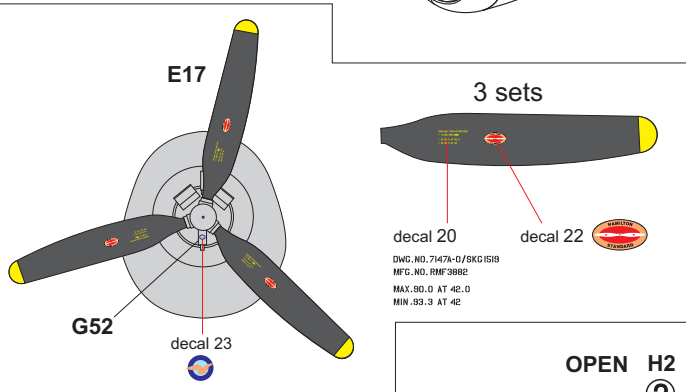
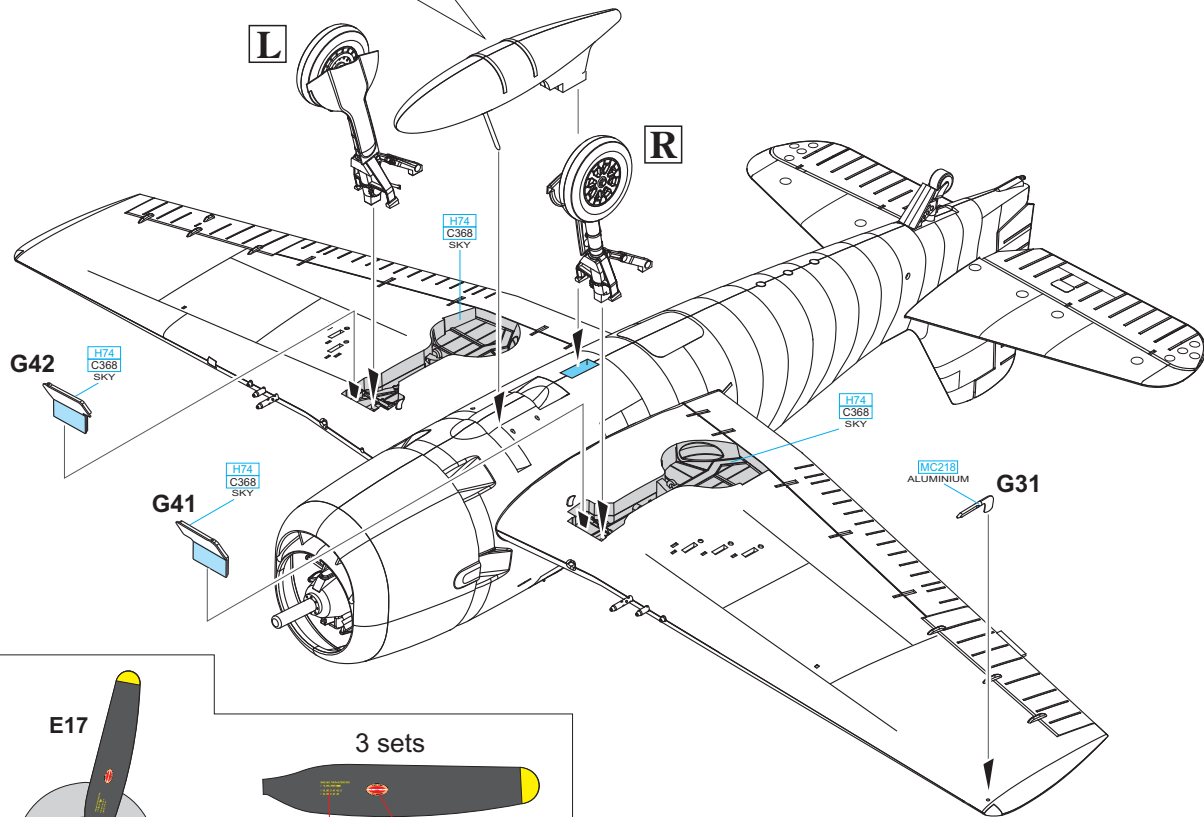
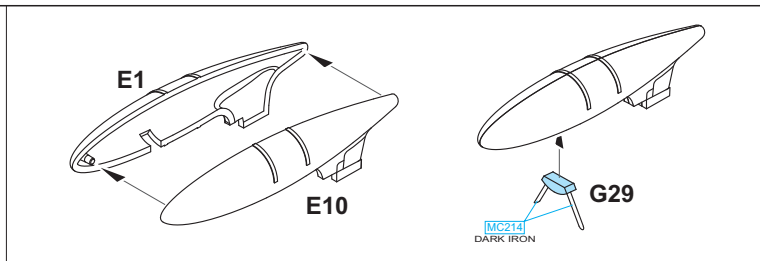

A7 - MARKING B

G30 - MARKING A

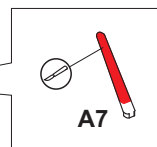

OPEN H2

CLOSED H1

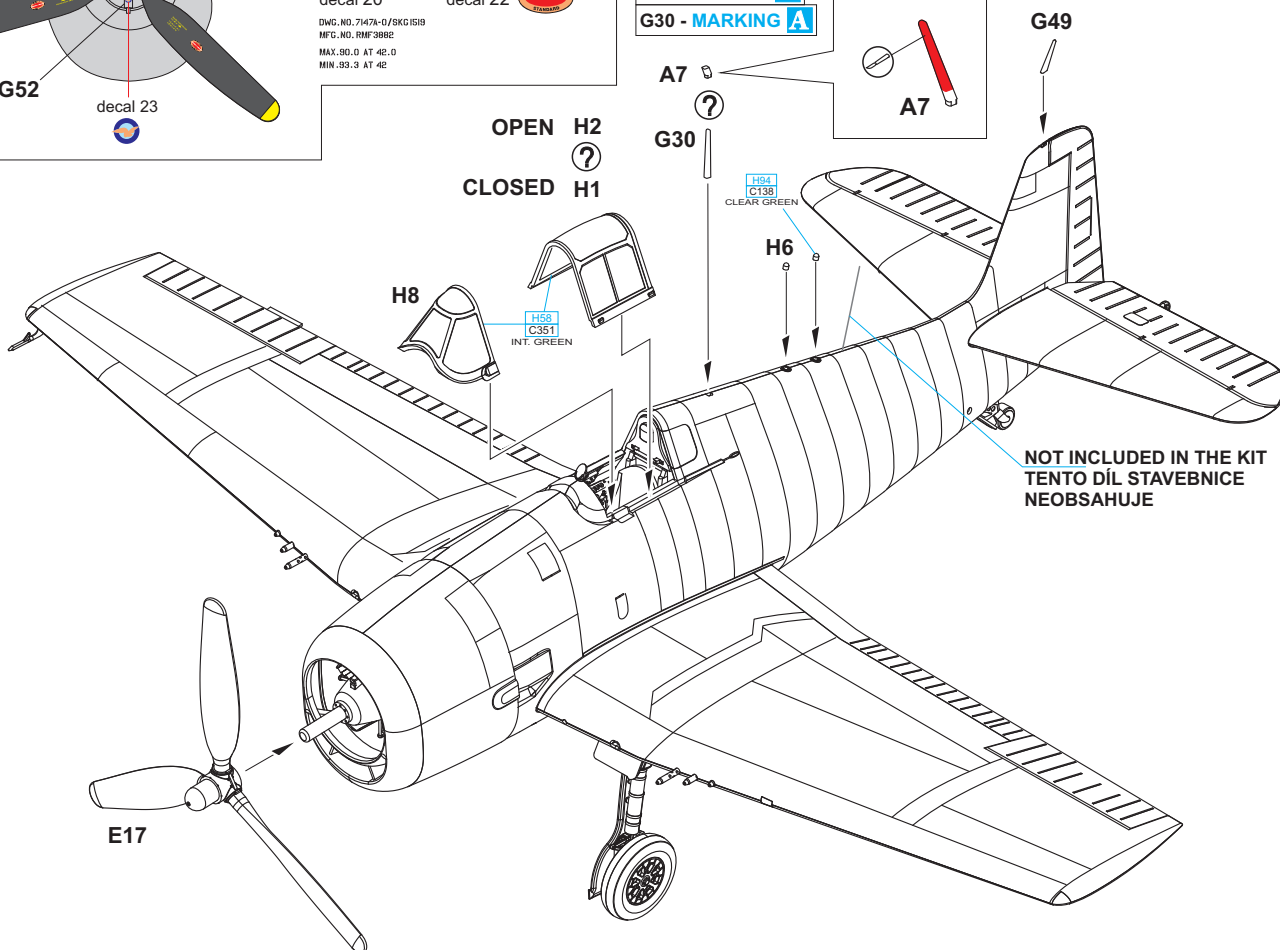

A s/n FN430, flown by P/O Hannay, No. 1844 Squadron FAA, HMS Indomitable, Indian Ocean, August 1944

No. 1844 Squadron was formed in December 1943 and was equipped with the F6F Hellcat. In February 1944, the unit boarded the HMS Begum and headed for the battlefields of the far east. Operating from the HMS Indomitable, the unit took part in attacks against Japanese occupied territory as members of the British Pacific Fleet, and later on the Japanese islands outright. Hellcats delivered to the British naval forces carried the standard scheme of the FAA composed of colours similar to Extra Dark Sea Grey and Dark Sea Grey on the upper and side surfaces, while the lower ones were painted in the American equivalent of Sky. Aircraft that were put in service against the Japanese carried a simplified version of the national roundels, where the red was left out to eliminate possible confusion with Japanese markings.

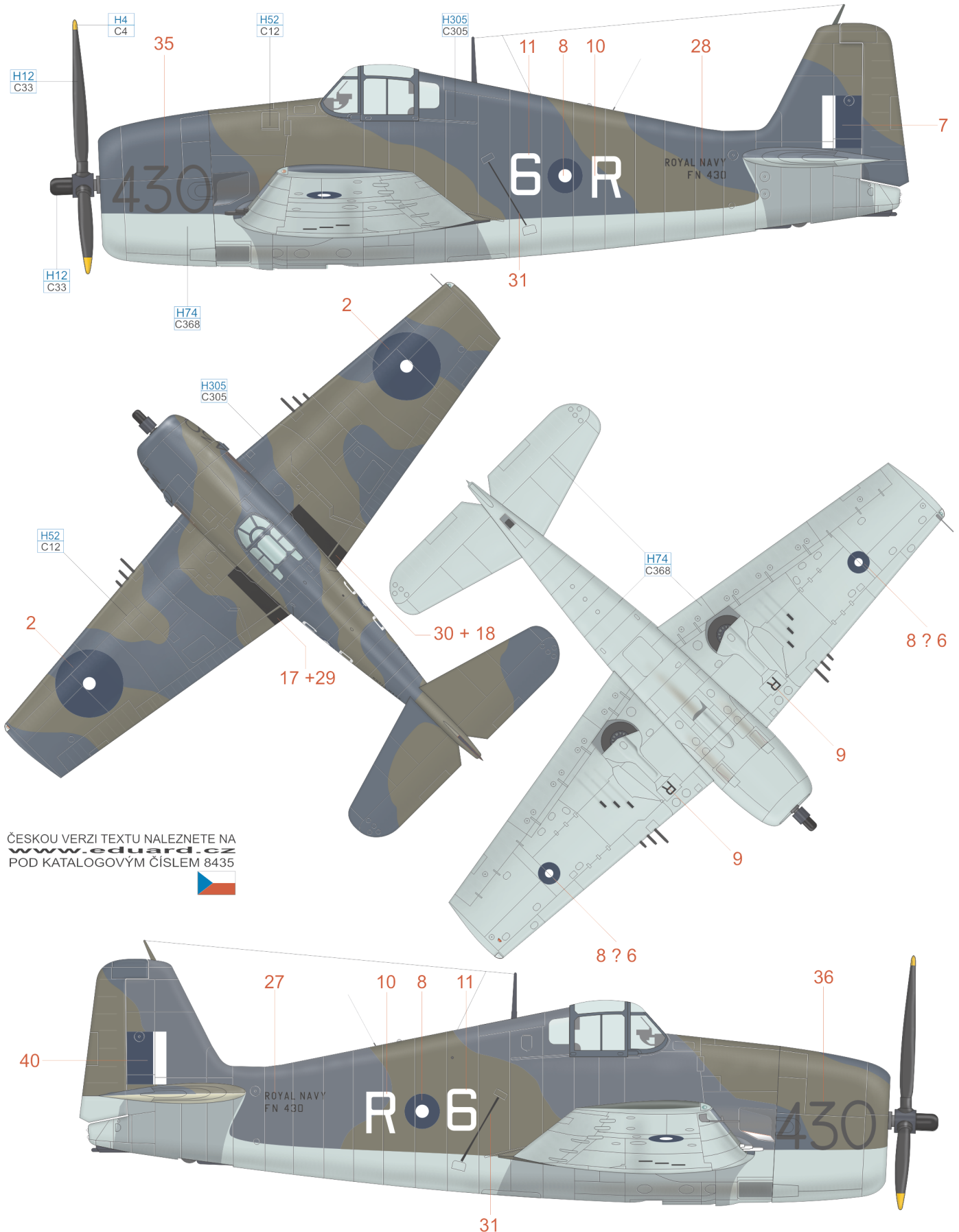

ČESKOU VERZI TEXTU NALEZNETE NA www.eduard.cz POD KATALOGOVÝM ČÍSLEM 8435



OLIVE DRAB H52 C12 OCEAN GRAY H305 C305 SKY H74 C368 BLACK H12 C33 YELLOW H4 C4

eduard

B s/n JV105, No. 800 Squadron FAA, HMS Emperor, Aegean Sea, September 1944

No.800 Squadron was formed on April 3rd, 1933 with the merger of 402 and 403 Flights. At the beginning of the Second World War, the unit was equipped with the Blackburn Skua, which was progressively replaced by the Fairey Fulmar and then the Hawker Sea Hurricane. In July 1943 it was the first unit within the FAA to be equipped with the F6F Hellcat, flying the type till the end of the war. In the following years and decades, No.800 Naval Air Squadron took part in combat over Korea, Malaysia, the Suez conflict, the Falklands War, and took part in operations over the Balkans and Afghanistan.

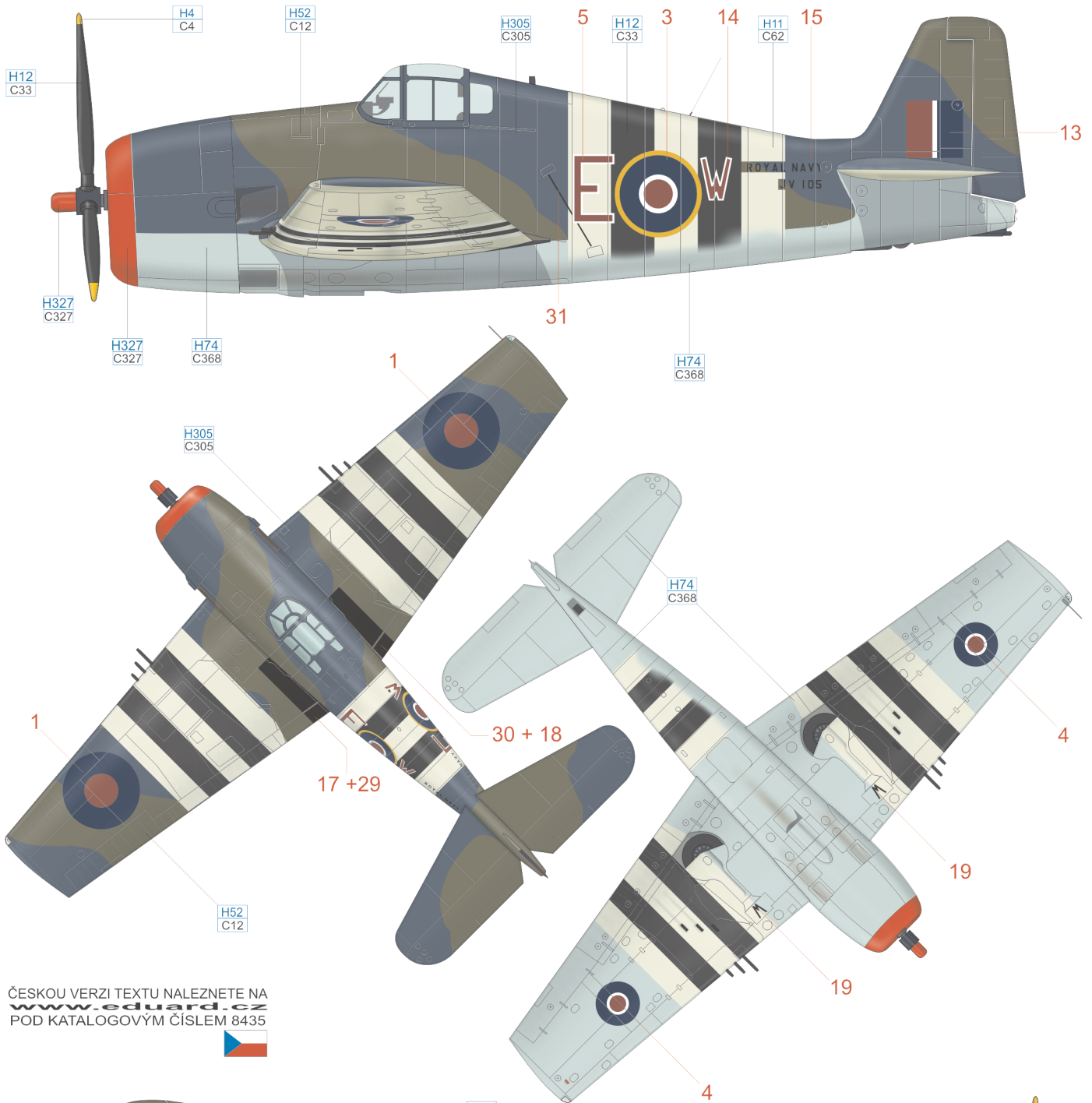

ČESKOU VERZI TEXTU NALEZNETE NA
www.eduard.cz
 POD KATALOGOVÝM ČÍSLEM 8435

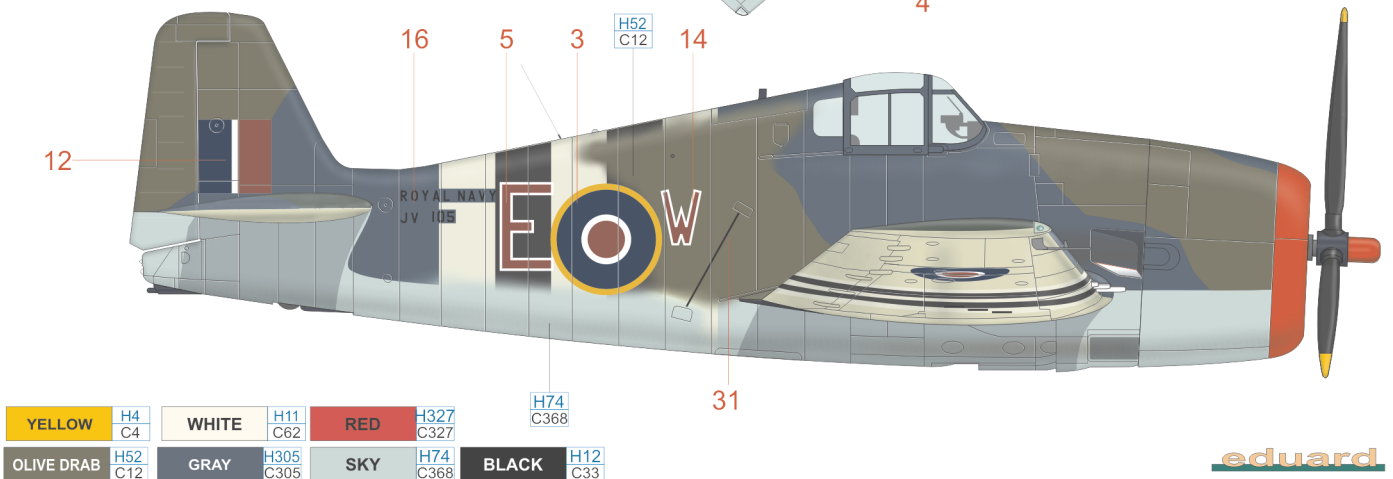

YELLOW	H4 C4	WHITE	H11 C62	RED	H327 C327
OLIVE DRAB	H52 C12	GRAY	H305 C305	SKY	H74 C368
				BLACK	H12 C33

