

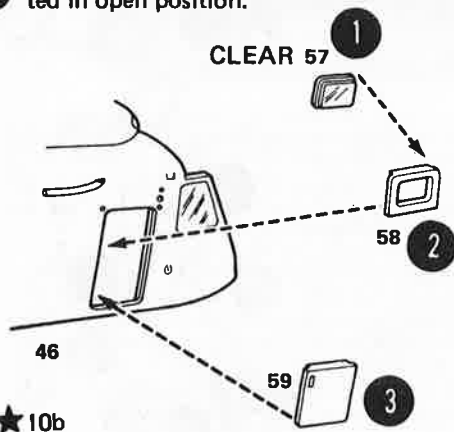



**8** NOTE: Doors may be cemented in open position.



**9** CLEAR RIGHT SIDE SHOWN

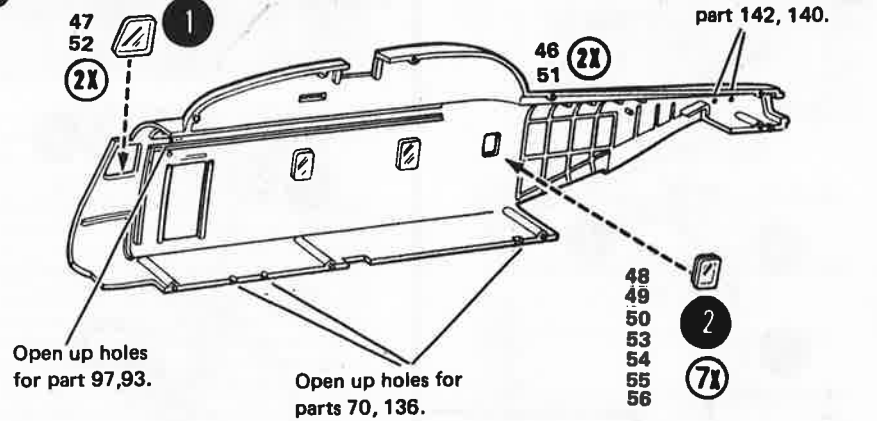

**10a**

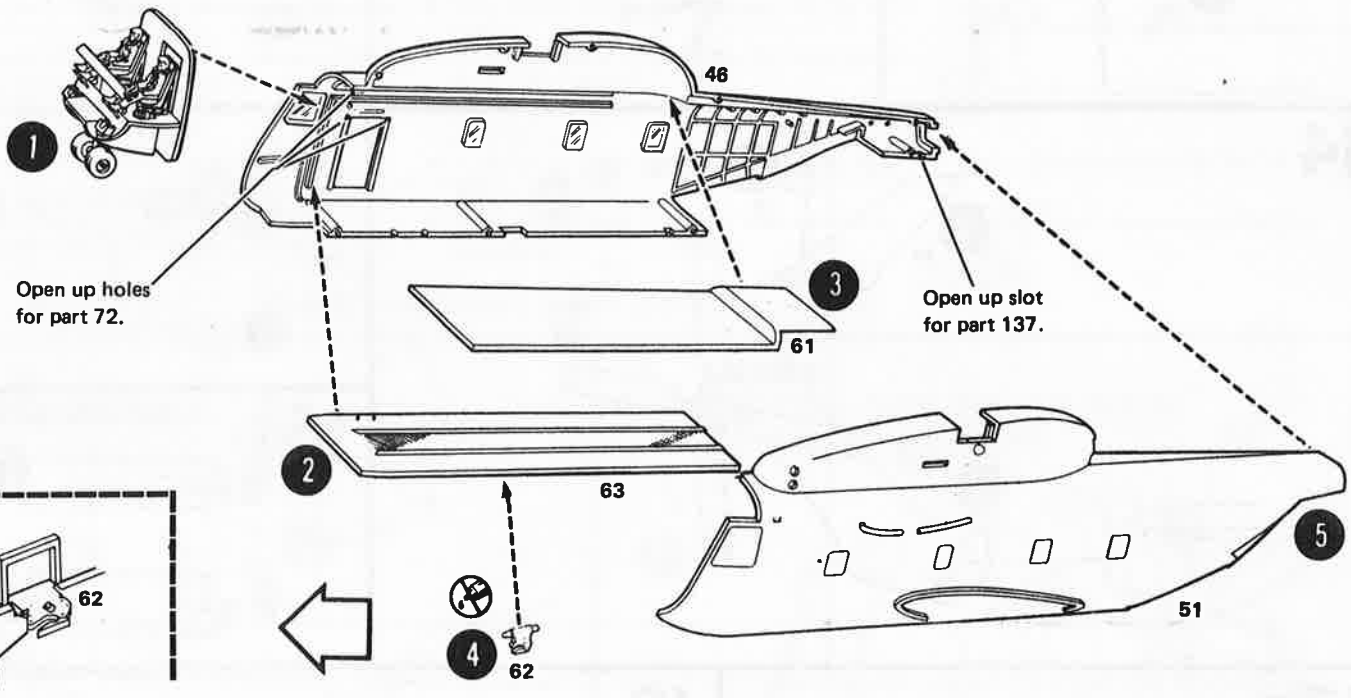

**10b** DOORS IN OPEN POSITION

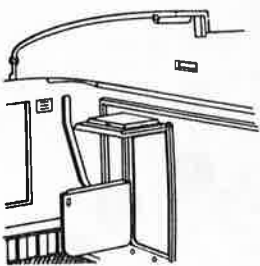

**11**

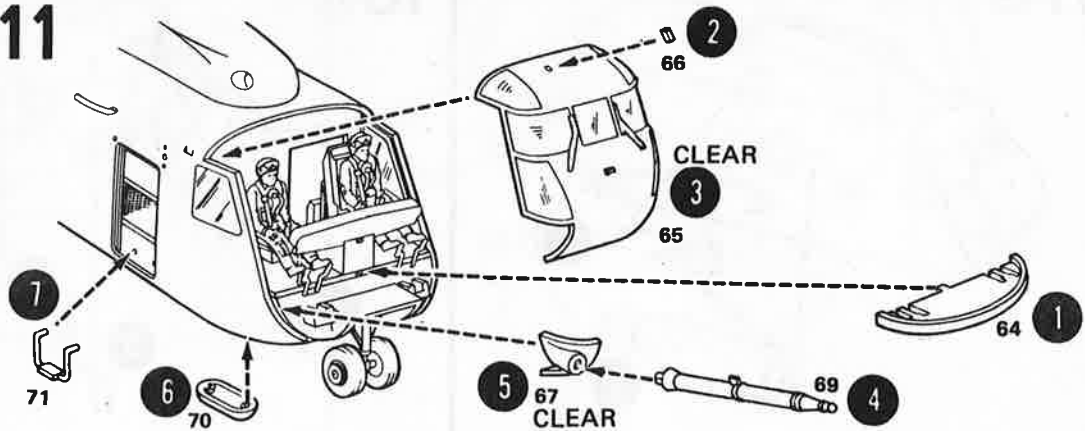

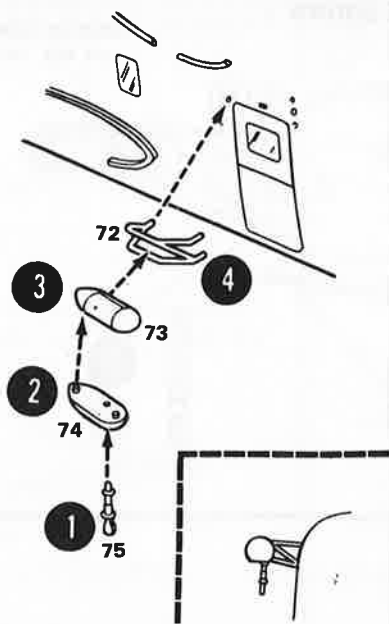
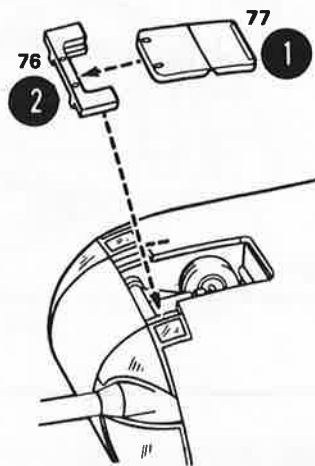
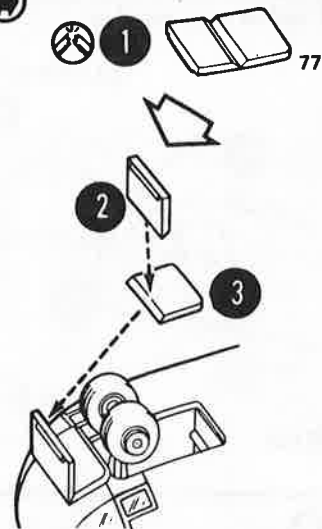
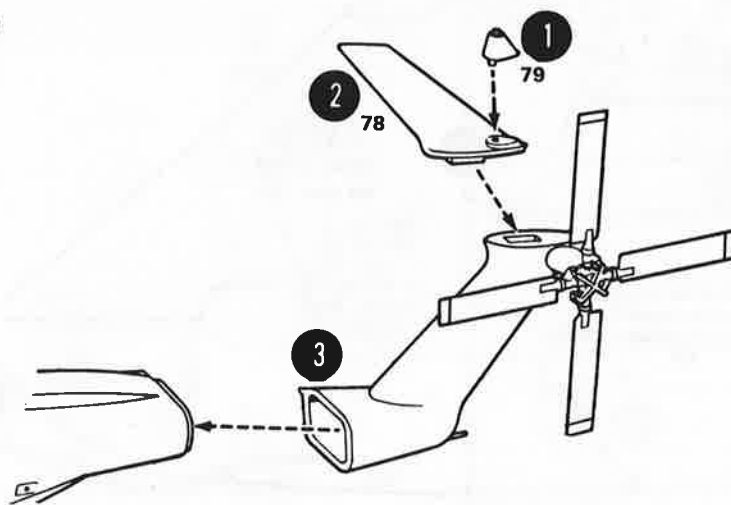
**12****13a****13b** **14****15** 

RIGHT SIDE SHOWN

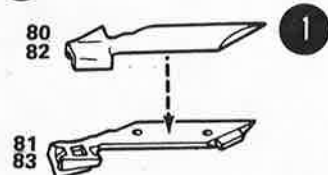
**16** 

RIGHT SIDE SHOWN

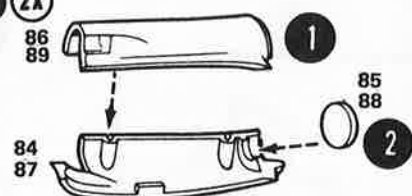
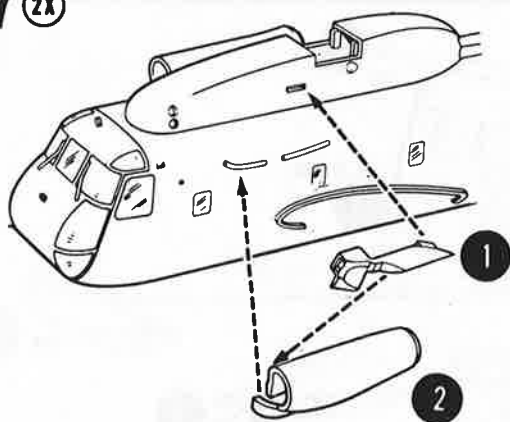
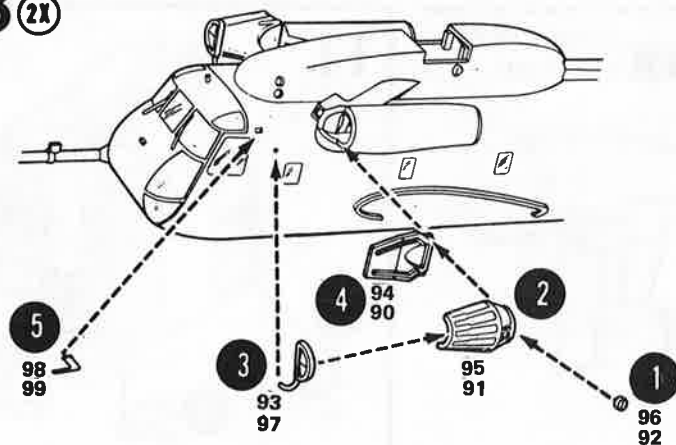
**17** **18** 

**19** (2X)

LEFT SIDE SHOWN

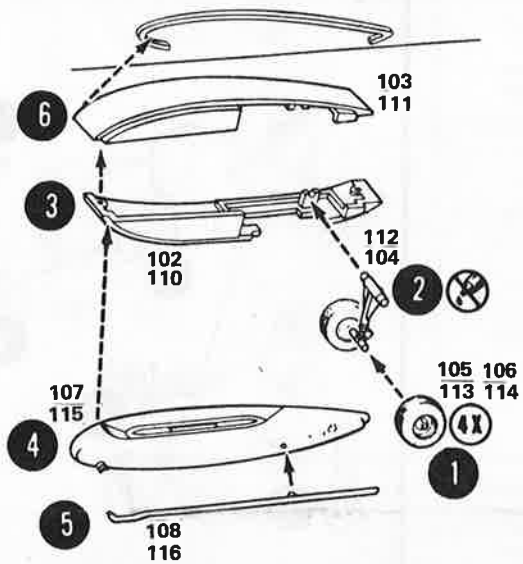
**20** (2X)

RIGHT SIDE SHOWN

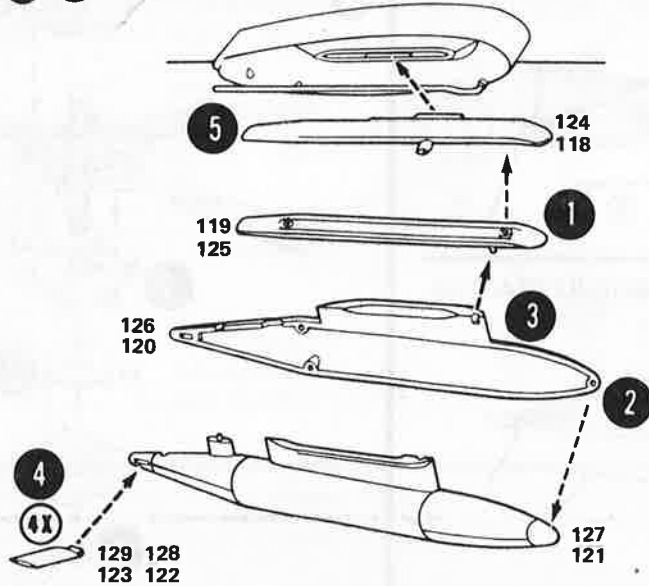
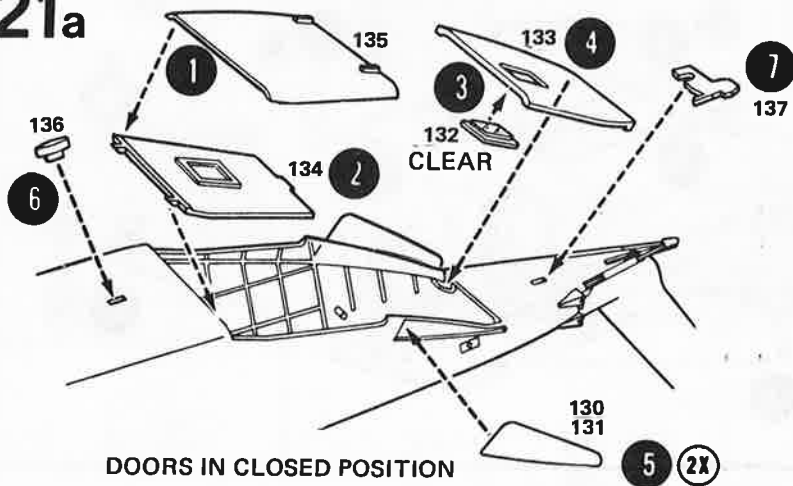
**21a**

DOORS IN CLOSED POSITION

**21b** (2X)

DOORS IN CLOSED POSITION

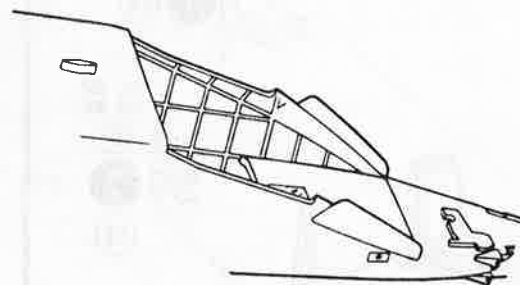
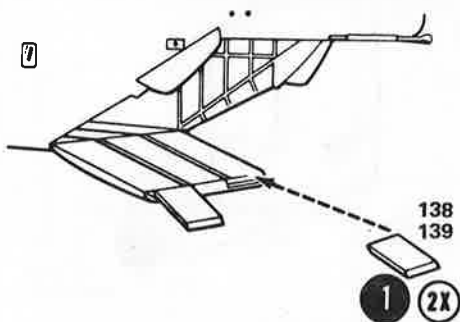
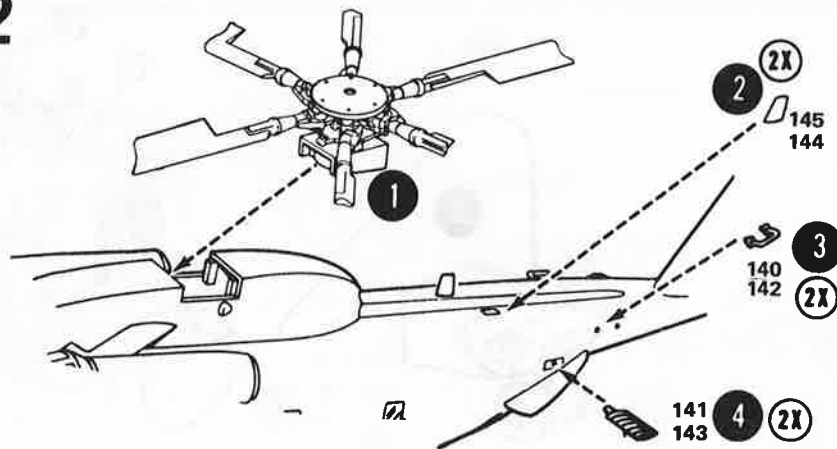
**21c** (2X) DOORS IN OPEN POSITION**22**

# SIKORSKY HH-53C OF THE 67TH AEROSPACE RESCUE AND RECOVERY SQUADRON, USAF, WOODBRIDGE, ENGLAND

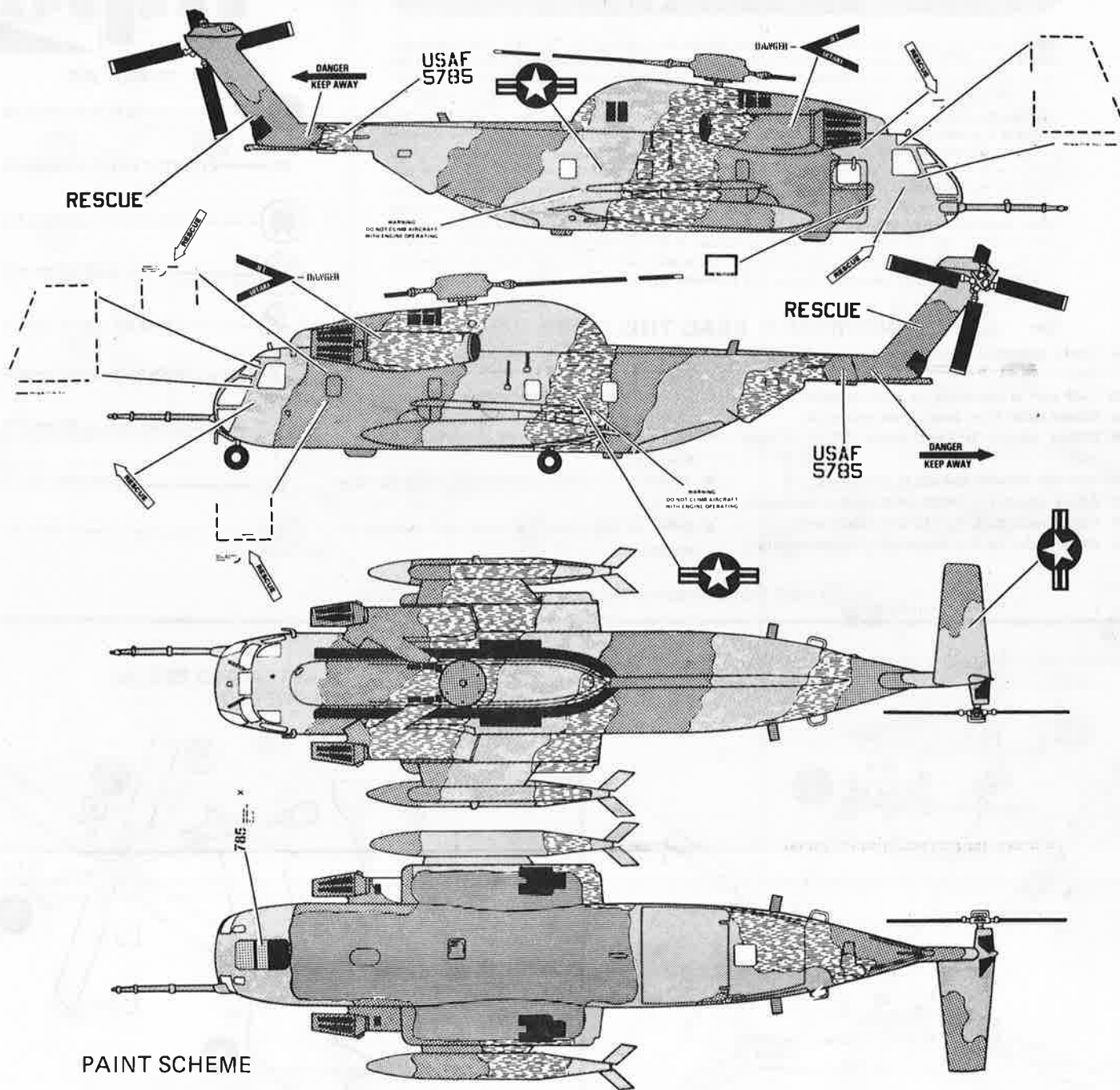

## PAINT SCHEME

A	BLACK
B	LT. GREY
C	O.D. GREEN
D	LT. BROWN

E	DK. GREEN
F	ZINC CHROMATE
G	FLESH

H	SILVER
I	YELLOW

USE FLAT PAINT

SEE BOX COVER FOR REFERENCE