



M88 A1G



Recovery Vehicle

The M88 Armored Recovery Vehicle was designated by U.S.Army to be the standard ARV evolved based on the M-74, which had the M4A3's chassis). The M88 was built on M48A2 chassis and use as many components as possible of the M48 tank family. A total of 1,075 M88 were built between 1960 to 1964 and saw extensive Action during the Vietnam War.

In 1975 M88 was fitted with AVDS-1790-2DR diesel engine made by TELEDYNE CONTINENTAL MOTORS to replace the old power plant with increase output up to 750bhp. Over the original M48A2. The improved version is designated as M88A1.

M88A1. ARV operated by four crews. At the front of the vehicle is a spade and a powerful winch. The crane system utilize an A-type Boom which maximum capacity is up to 25 tons. M88A1's allowable speed is about 26 mph. with range well over 300 miles.

In 1985, FGR commenced an upgrade program for their M88 starting with the crane to match the towing power of the crane to the M88 A1, 45 Metric Ton level. A gear box is also introduced to improve the cable's lifting ability to 25 Metric Ton. A new aux. power unit is also introduced for the hydraulic system to enable refueling while the recovery is in session. The M88 A1G also received the MG3 as it's armament.

M88全装軌式装甲戦車回収車は アメリカ陸軍がM74戦車回収車（M4A3の車体を利用）に続いて開発した標準型ARVである。1960年の生産開始から1964年の間に1075輛が生産された。M88は、M48A2戦車をベースに開発され可能な限りM48戦車系との部品の共通化が図られており、後のベトナム戦争では、全期間を通じて使用されている。

1975年 M88は搭載エンジンを、テレダイン・コンチネンタル・モーターズ社が製造したAVDS-1790-2DRディーゼルエンジンに換装したことにより、750馬力の高出力を得ることとなる。もとのM48A2を上回る出力を得たこの車輛は、M88A1と呼称されたのである。M88A1戦車回収車は、4名の乗員によって操作され、車体前面にはドーザーブレードを装着、最大吊り上げ能力25トンのAタイプブームクレーンを装備しており、車上には防御用として、50口径機関銃を搭載していた。M88A1の最高速度は時速41.6km、航続距離は480kmであった。

1985年 ドイツ連邦陸軍は保有するM88の近代化に着手した。巻揚げ機の改良により、M88A1と同等の45トンの牽引能力を持たせることに成功し、また、クレーンの吊り上げ能力も25トんに強化された。さらに、補助の油圧式装置に燃料を供給する新しいパワーユニットが装備され、最終的にはドイツ製のMG3機関銃が、オリジナルの機関銃に替わって装備された。これらの改修されたドイツ連邦軍版M88は、M88A1Gと呼称されたのである。

M88全履帶裝甲救濟車是美國陸軍繼M74救濟車(使用M4A3底盤)所開發的救濟車種,於1960年正式上線生產,至1964年已生產了1075輛,M88是以M48A2戰車為基礎所發展,許多零件能和M48系列戰車共用,爾後M88也被使用於越南戰場。

其後BYM公司於1975年將原來M88的發動機換裝為大陸汽車公司(TELEDYNE CONTINENTAL MOTORS)之AVDS-1790-2DR型柴油發動機,將馬力提昇超過原來M48A2戰車的輸出馬力,並正式命名為M88A1。

1985年時西德陸軍將手中的M88提升其性能,首先是絞盤的改良使其達到與M88A1同一級45公噸的曳引力,並設計一個有孔的金屬盒子,於吊掛時讓鋼纜從中穿過,如此也能提升吊掛重量至25公噸,此外,新的輔助動力單位能夠供動力給一個輔助液壓系統,使其在工作時發揮重新注燃料的功能,車身的武裝則以西德自製的MG3機槍來取代。

Illustration:圖示說明



Method For Applying Decals:

1. Clean Model Surface With Wet Cloth.
2. Cut Out Of Decal Sheet And Dip Them In Water For 15 Seconds.
3. Place it on proper position on model.
4. Slide off base paper leaving decals On Model With Wet Finger Tip.
5. Move Decals To Exact Position, Push Out Excess Water Under Decal With Soft Cotton Cloth.
6. When Decals Get Dry Then Complete.

水貼紙使用說明:

1. 將模型表面擦乾淨
2. 將貼紙剪下泡入清水中約15秒
3. 將泡濕之貼紙取出置於欲貼處旁
4. 用指尖輕推貼紙表面使其滑出底紙
5. 將貼紙調整至適當位置並輕擦拭水份
6. 待其自然乾燥後即完成

Color list: 塗料表

Color	Brand	GSI Creos (Gunze Sangyo)			Humbrol	Revell	Life Color
		Hobby Color	Mr. Color	Mr. Color Spray			
Olive drab(2)	橄欖綠	H-78	C-38	J-38	66	46	UA106
Khaki green	卡其綠	H-80	C-54				
Steel	黑鐵	H-18	C-28	J-28	53	91	LC76
Tire black	輪胎黑	H-77	C-137		85	302	
Bright blue	寶藍	H-15	C-65	J-65	14	51	LC60
Red brown	紅褐	H-47	C-41	J-41	160	383	
Khaki	卡其	H-81	C-55		159		
Leather brown	皮革	H-47	TC-11	J-41	160	383	
Bronze green	青銅		TC-10		86	361	UA002
Tar black	瀝青	H-12	TC-12	J-33	33	08	LC02
Black	黑	H-2	C-2	J-2	21	07	LC52
Red	紅	H-3	C-3	J-3	19	31	LC56

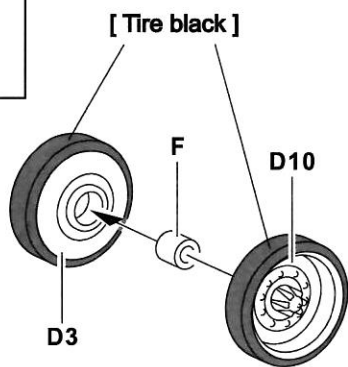
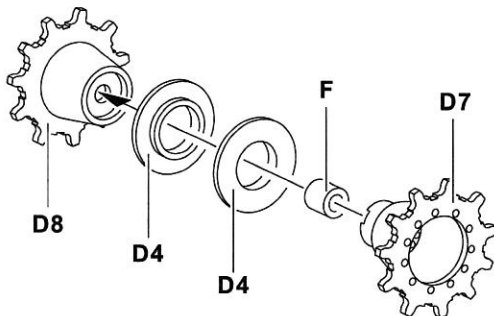
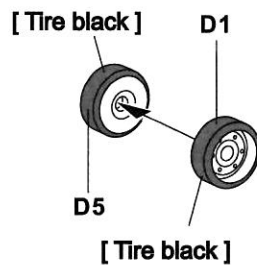
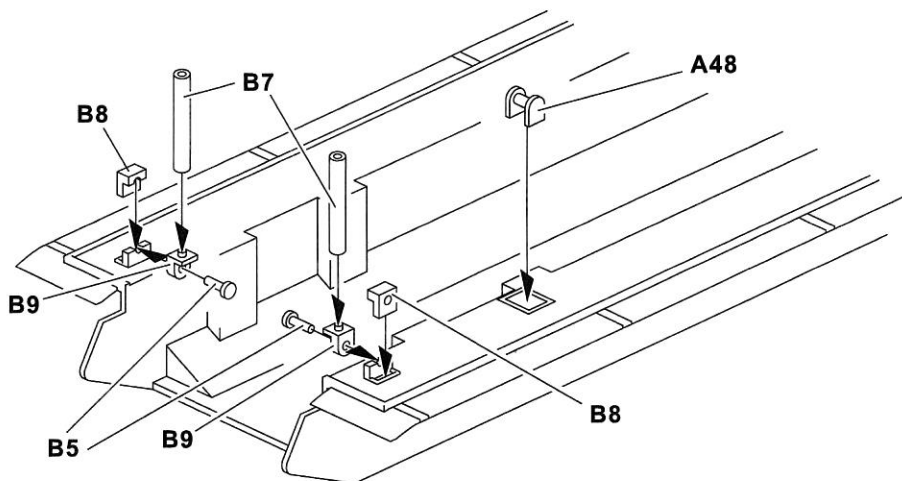
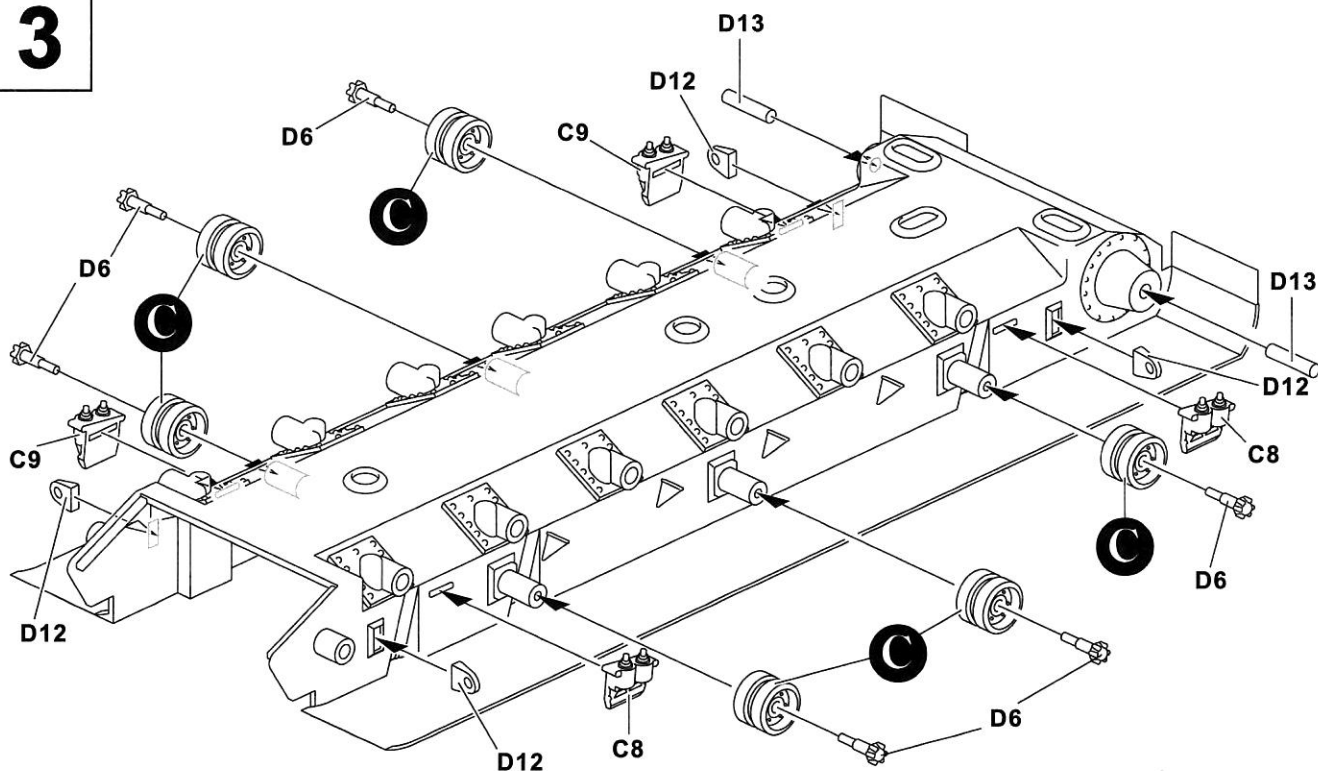
1**A** ×14**B** ×2**C** ×6**2****3**

4

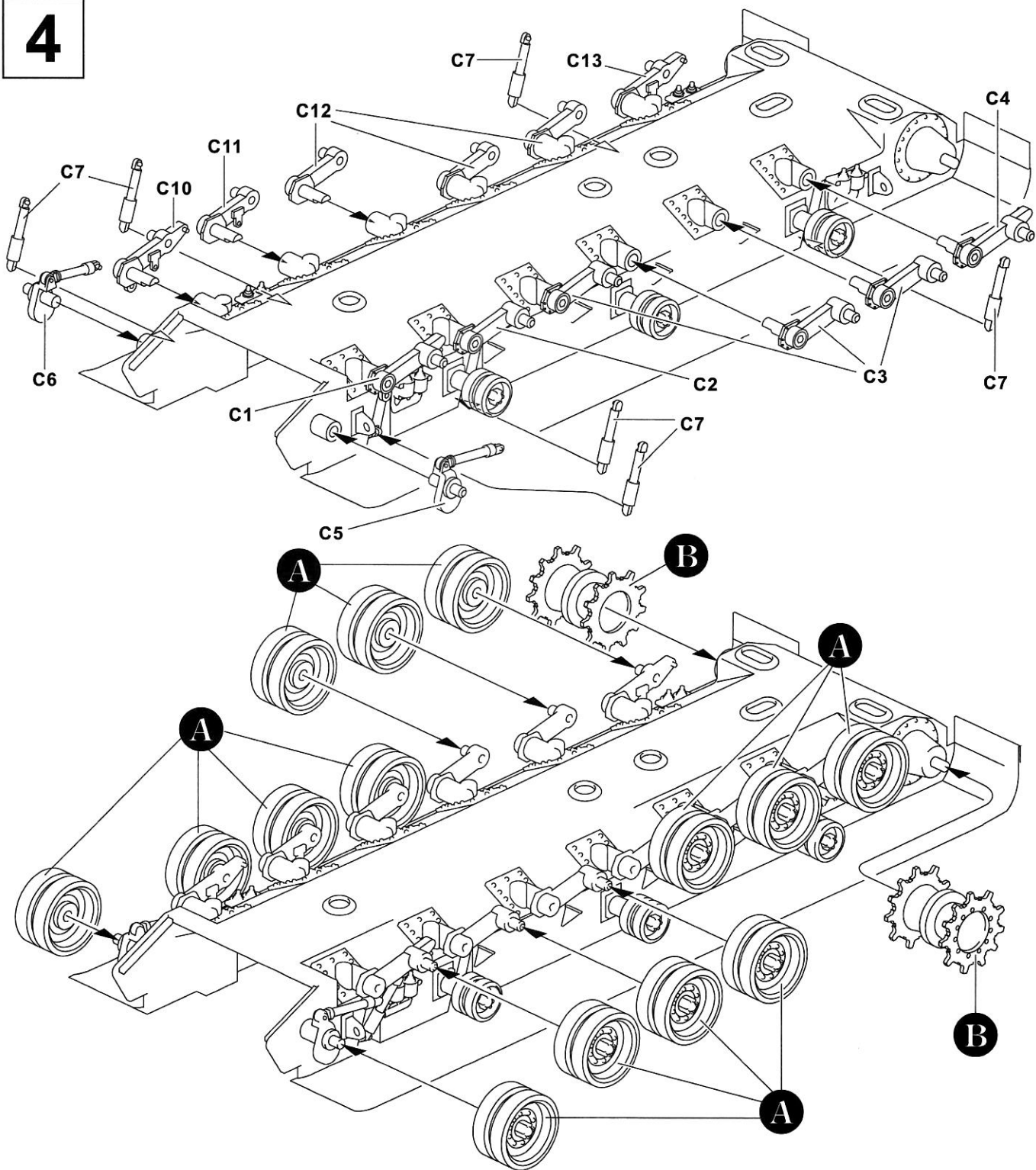

5

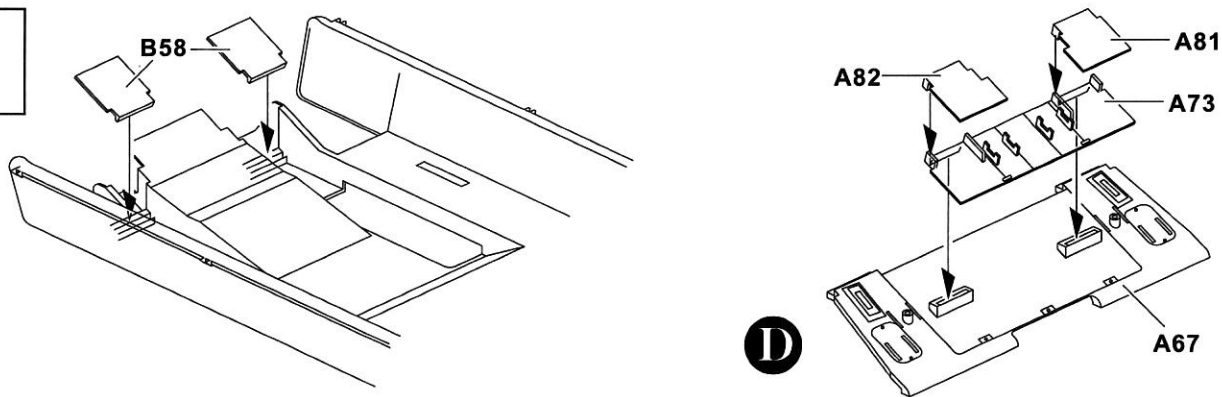

6

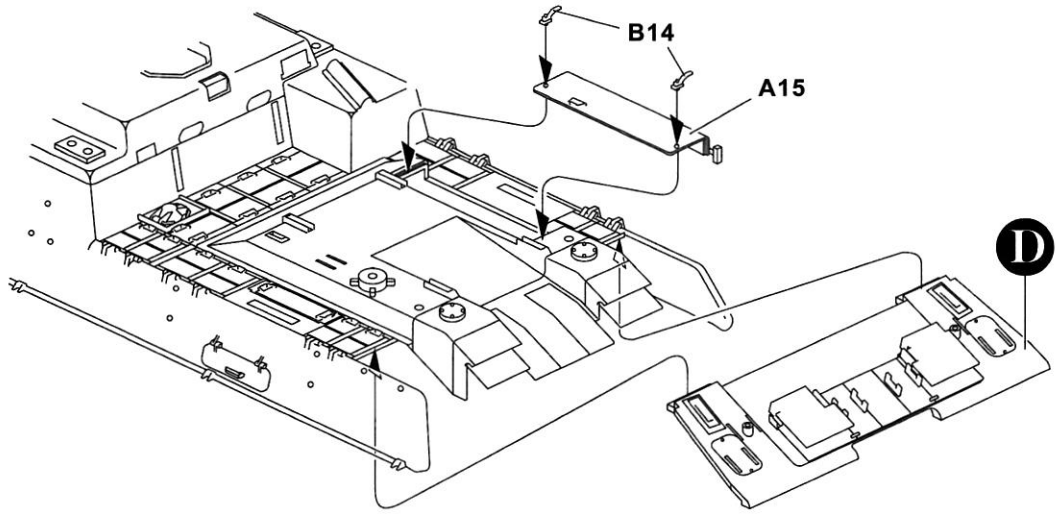

7

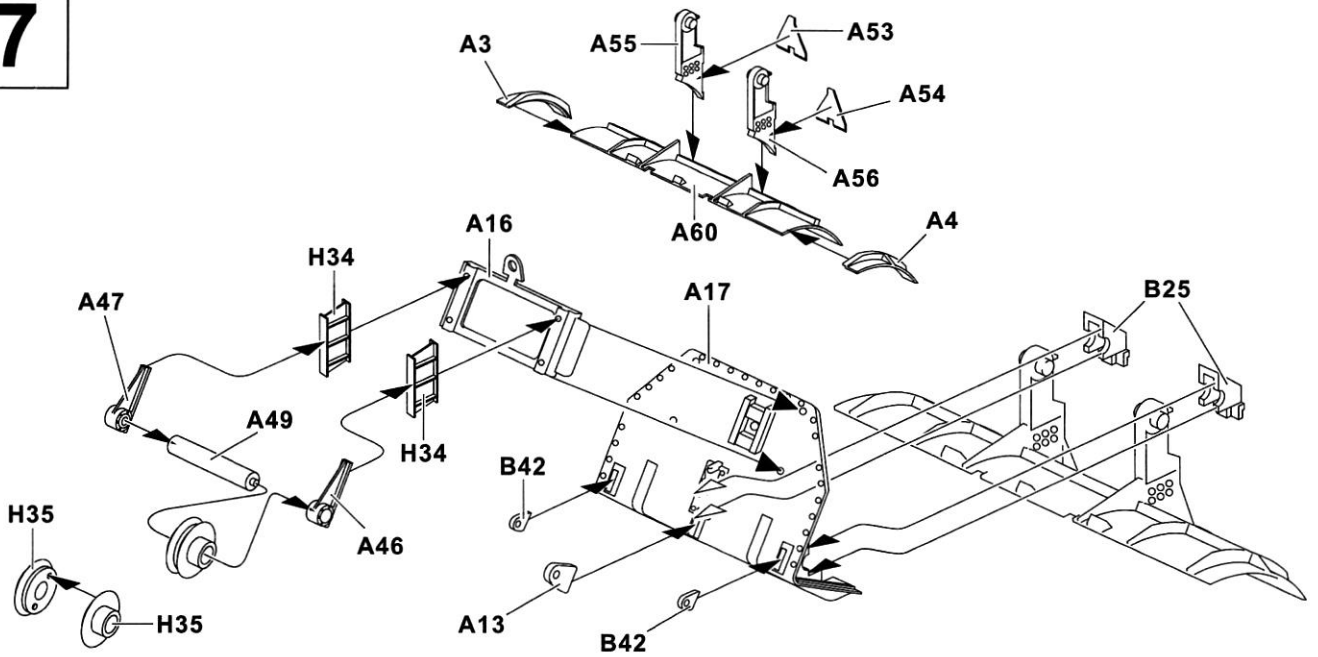

8

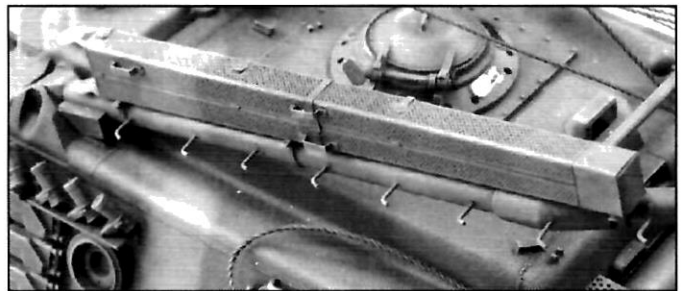
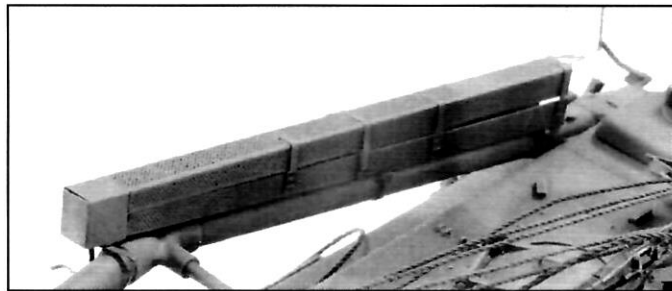
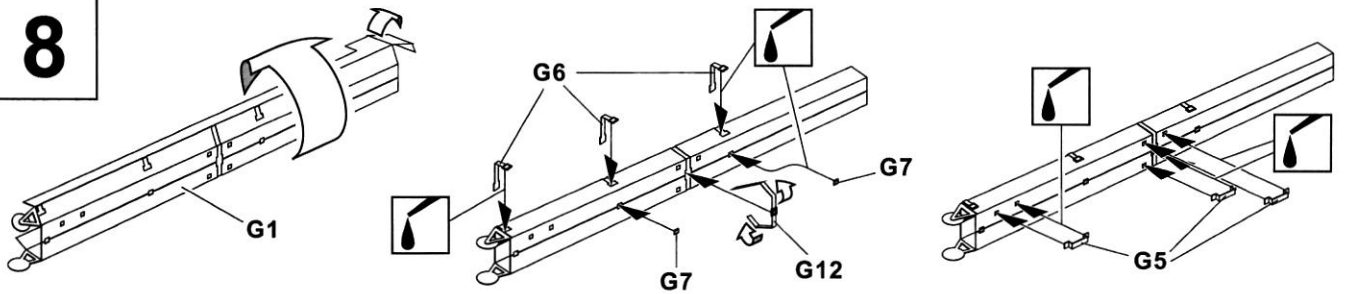

9

E ×2

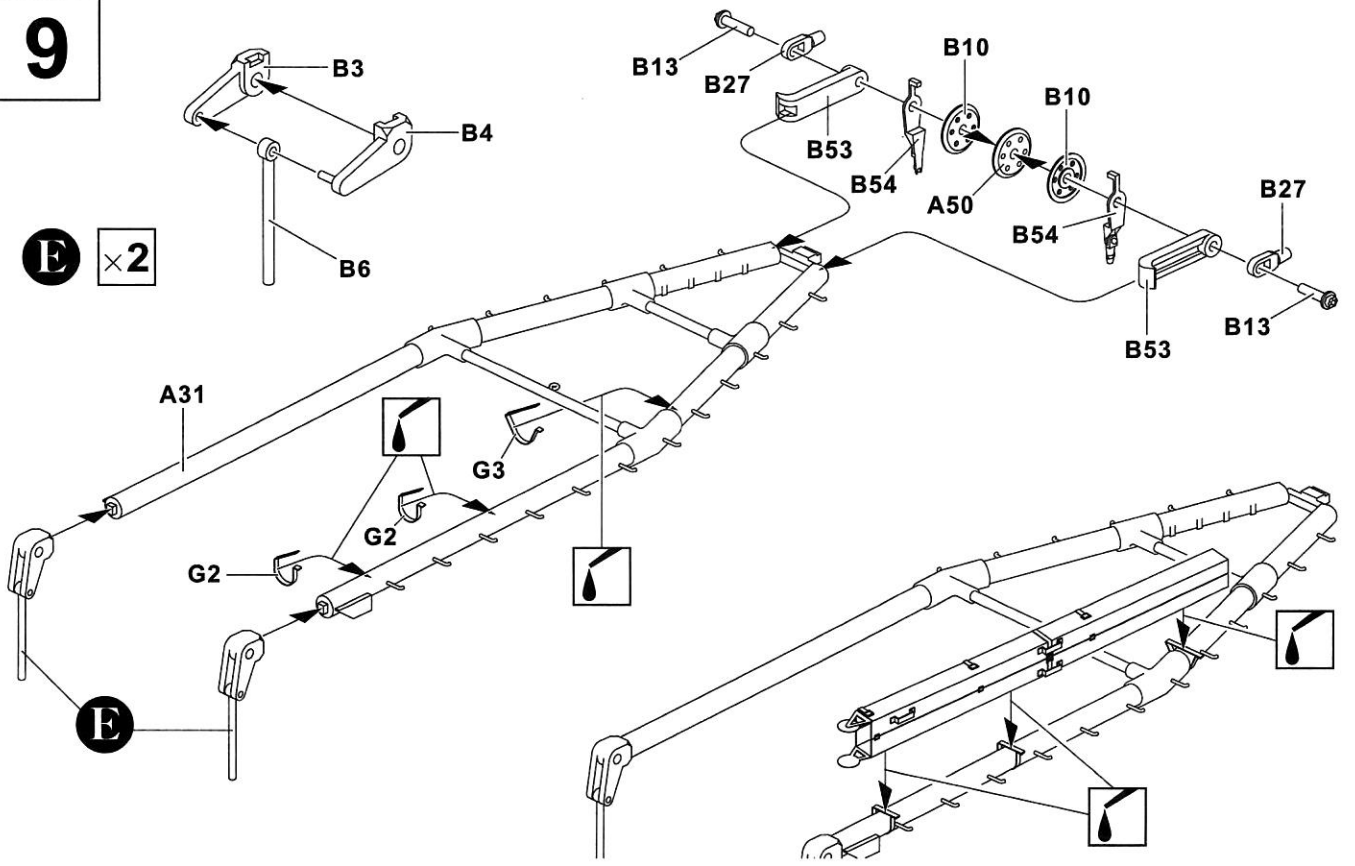

10

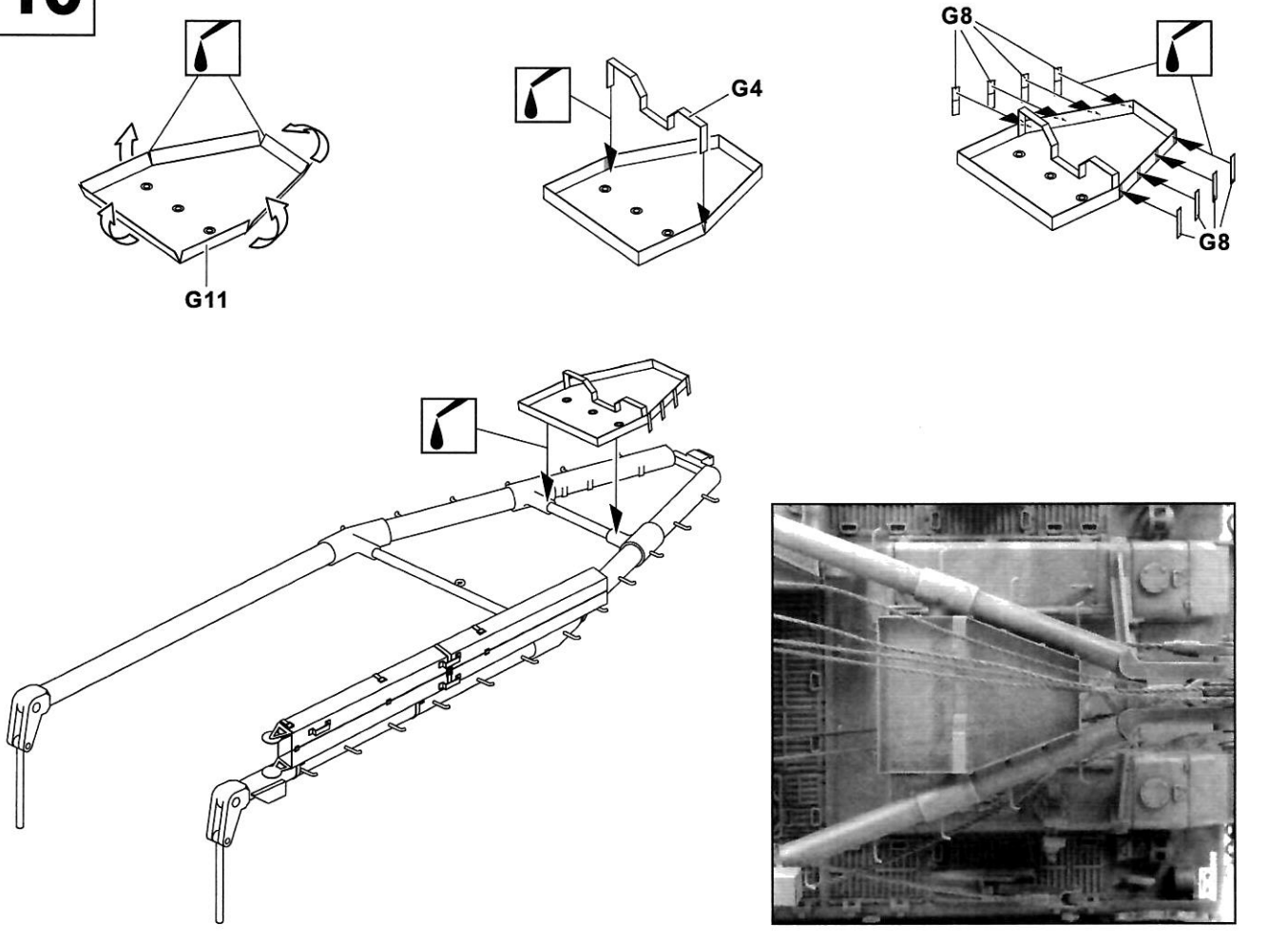

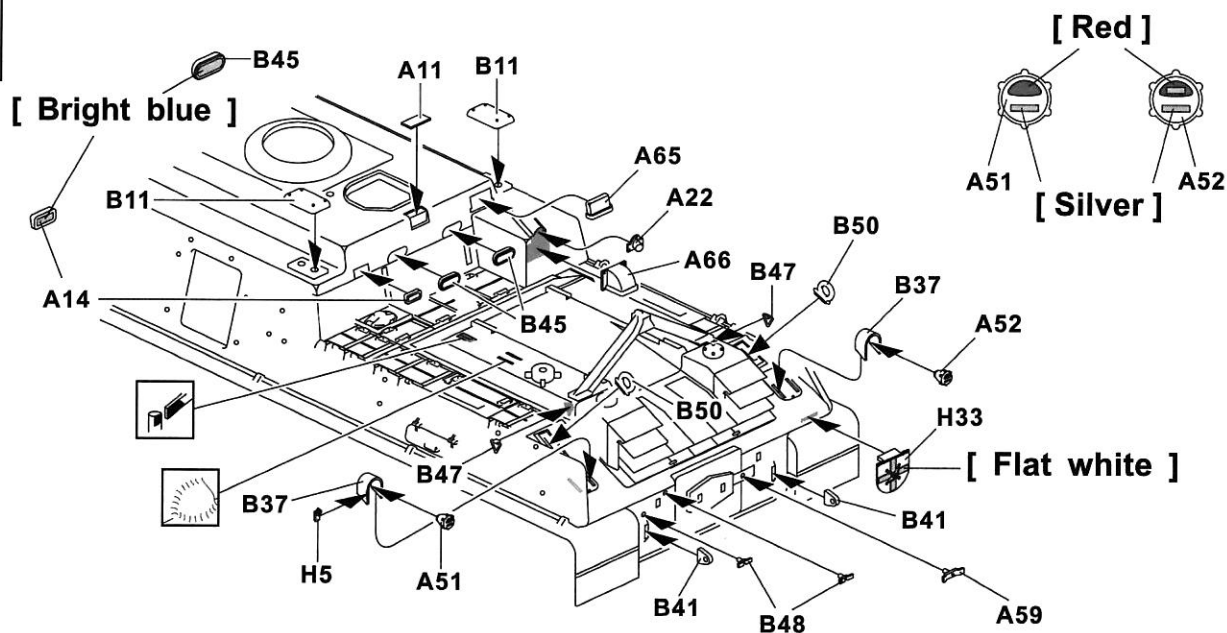
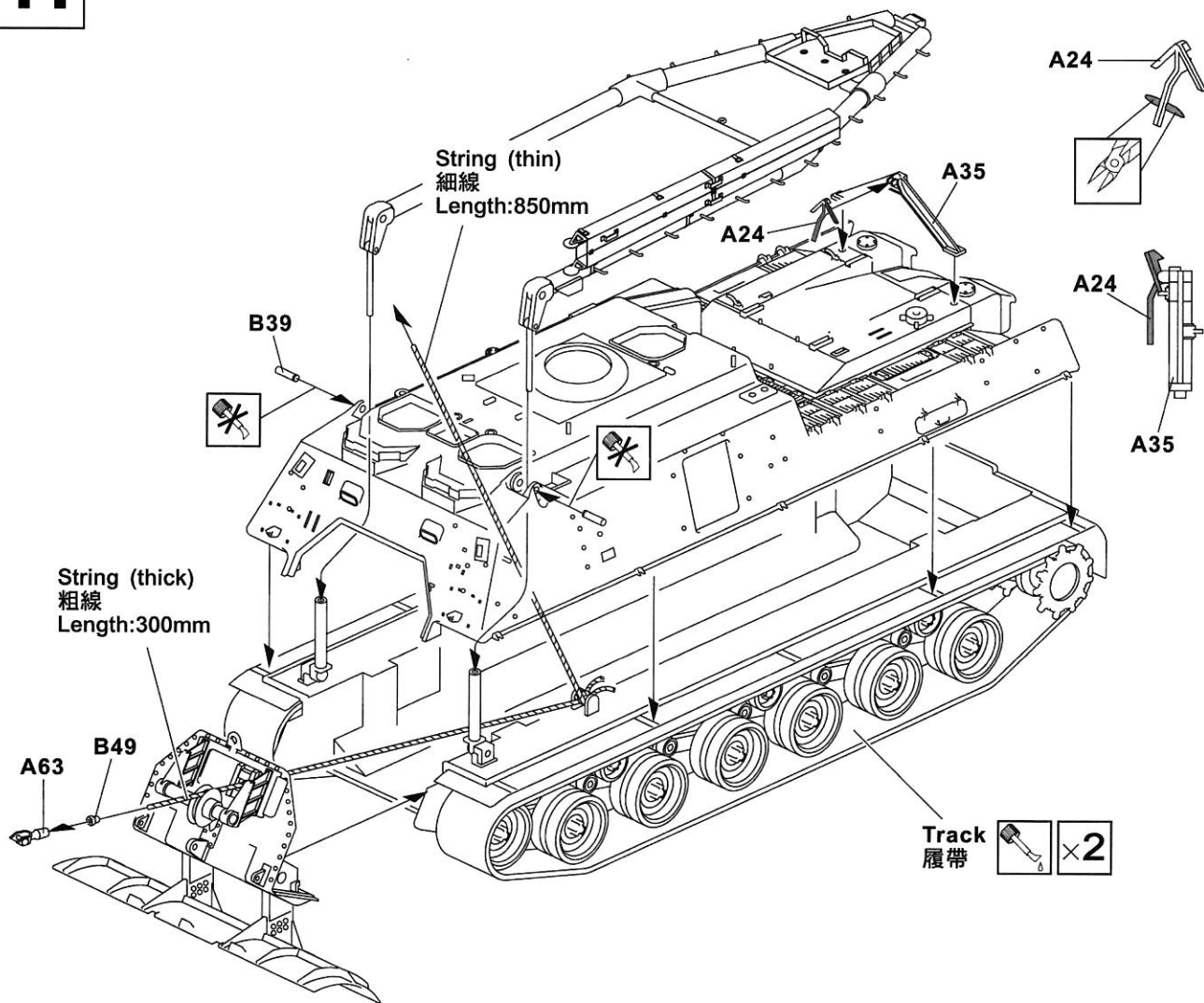

13

[Silver]

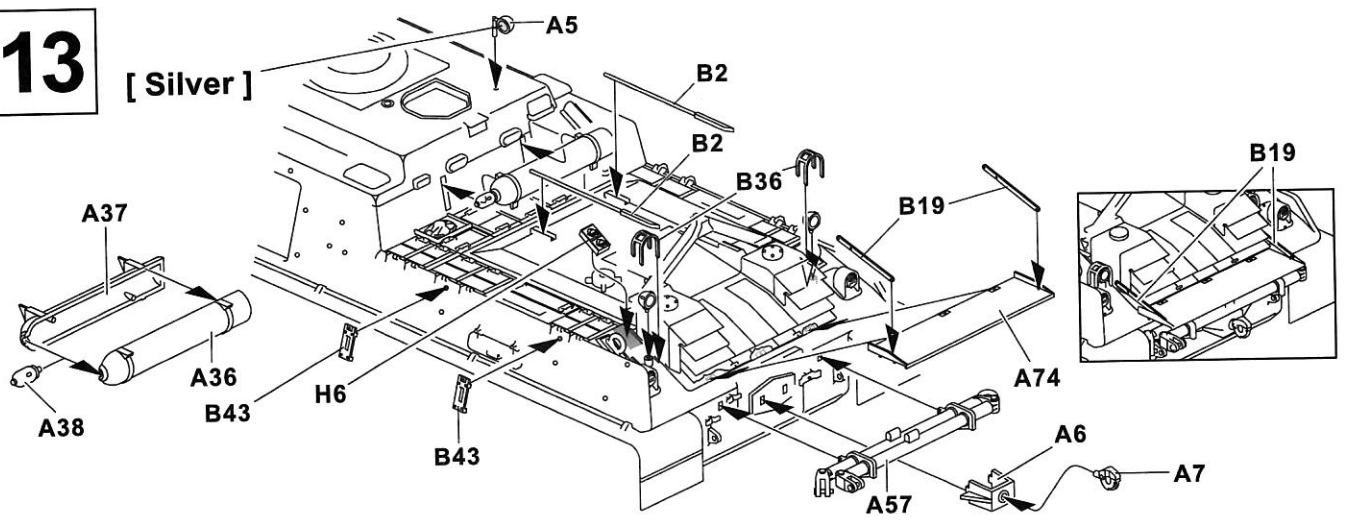

14

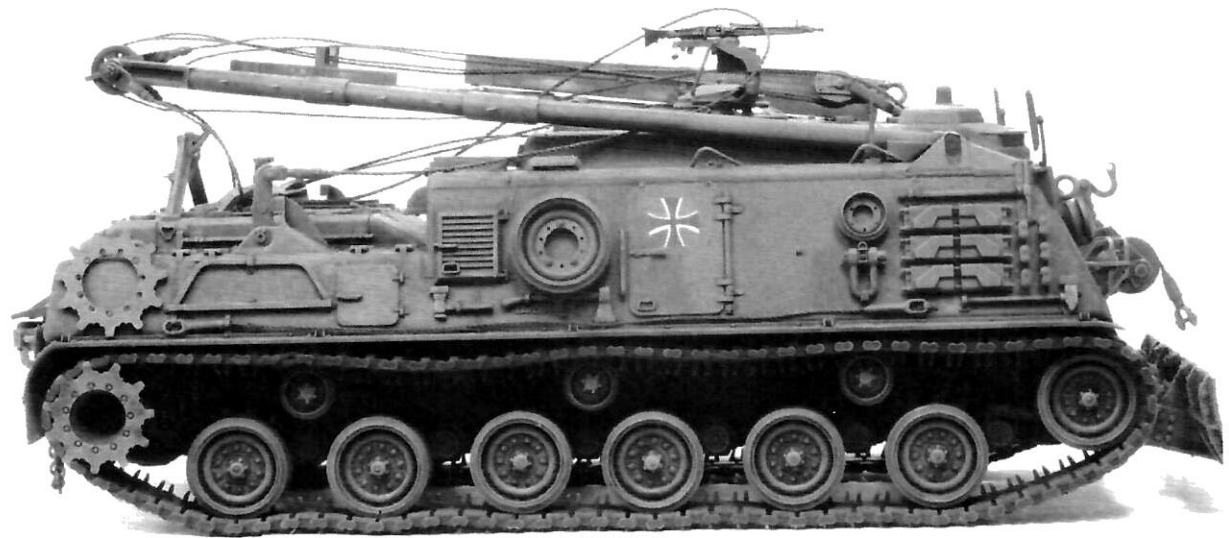
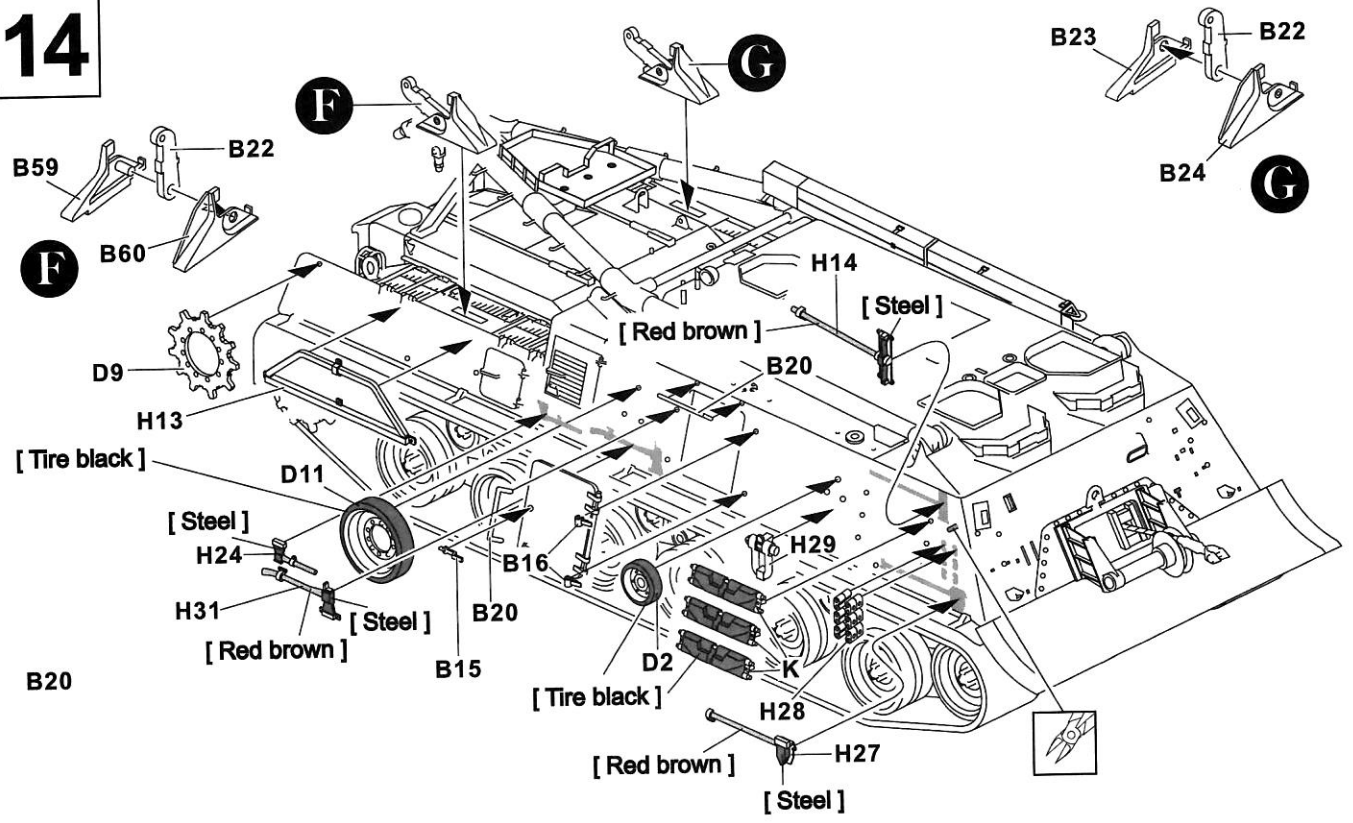

15

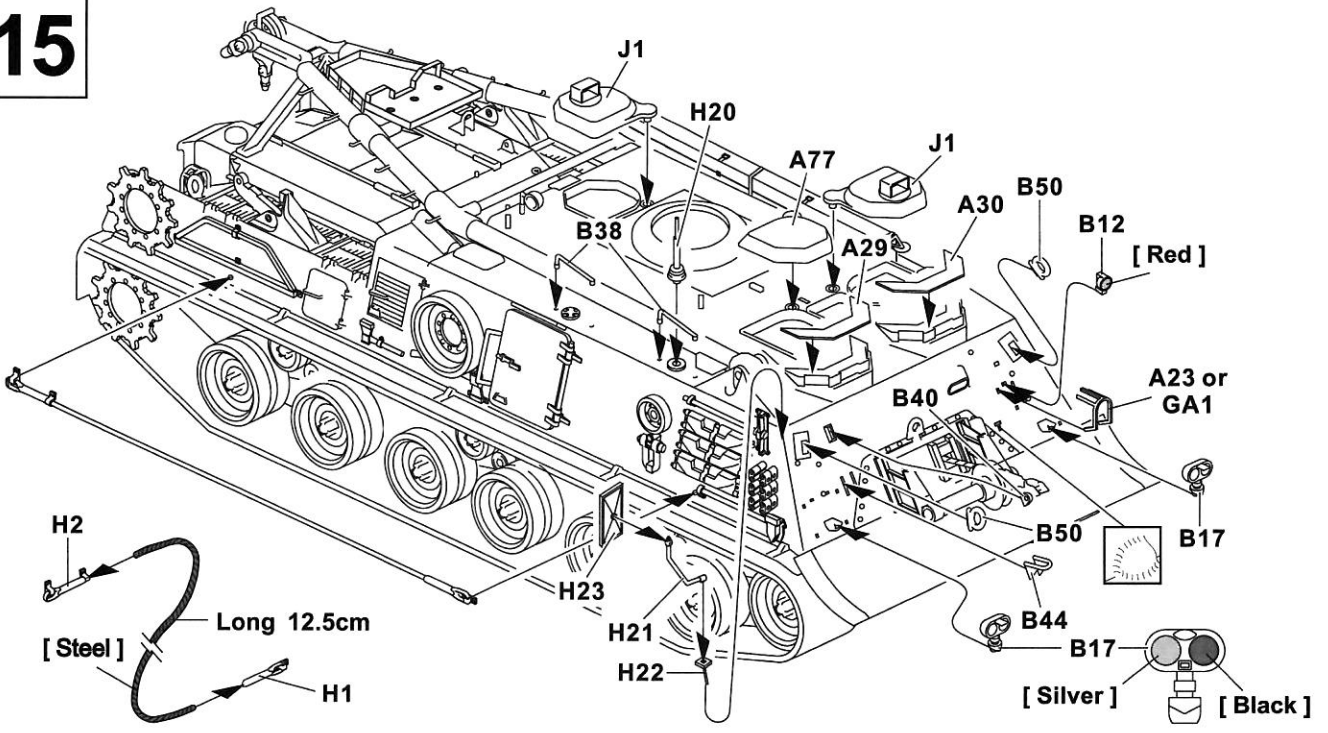

16

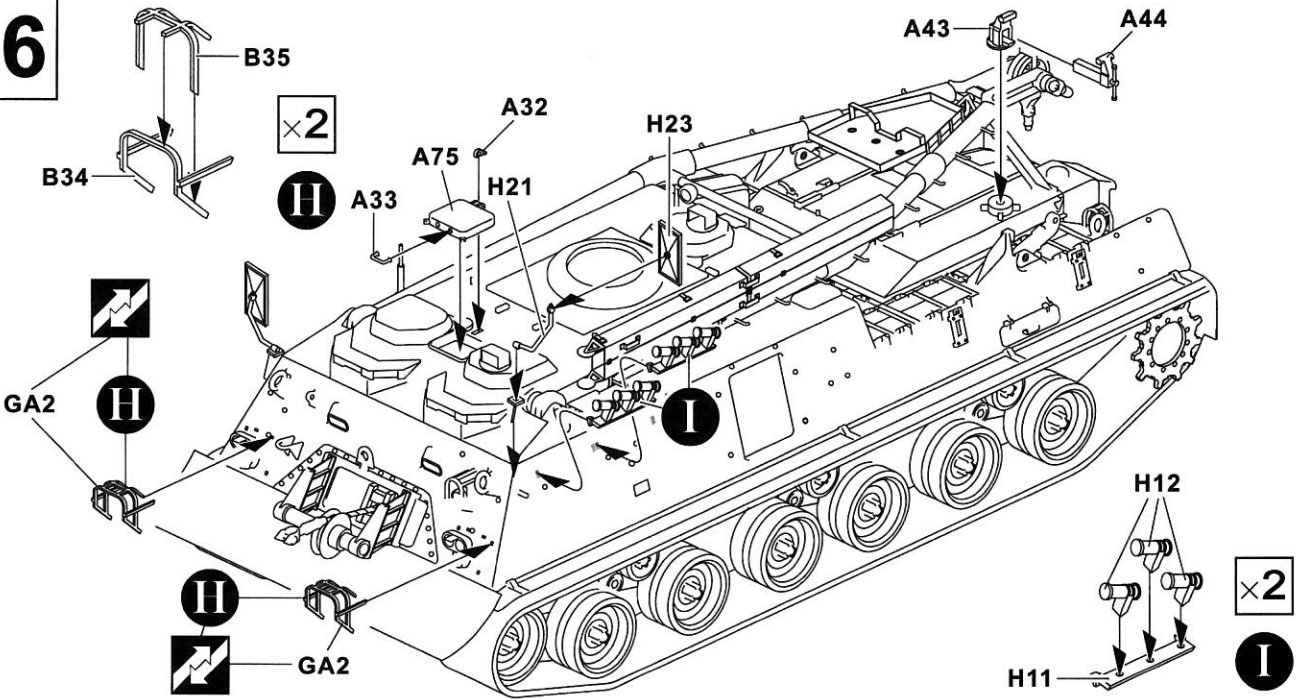

17

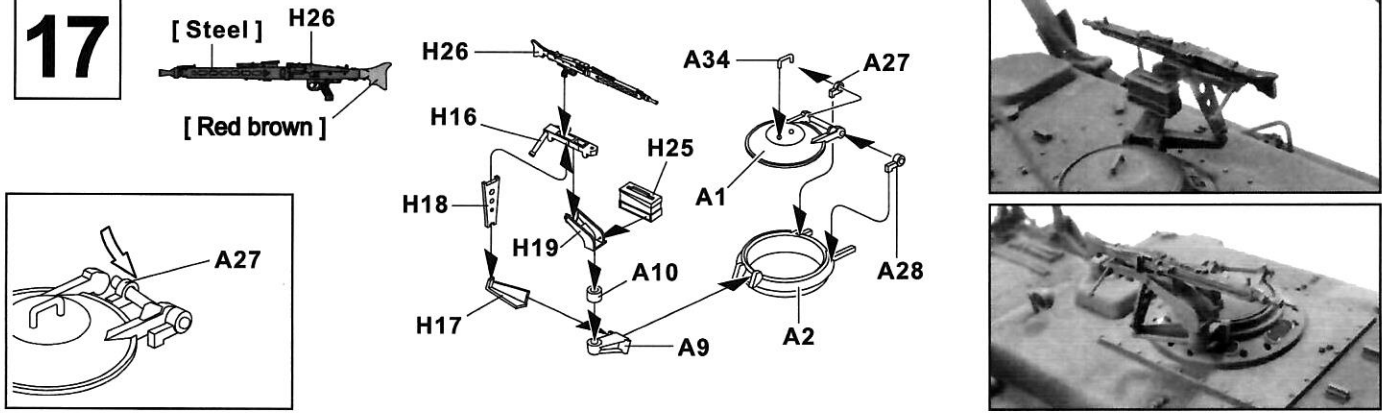

18

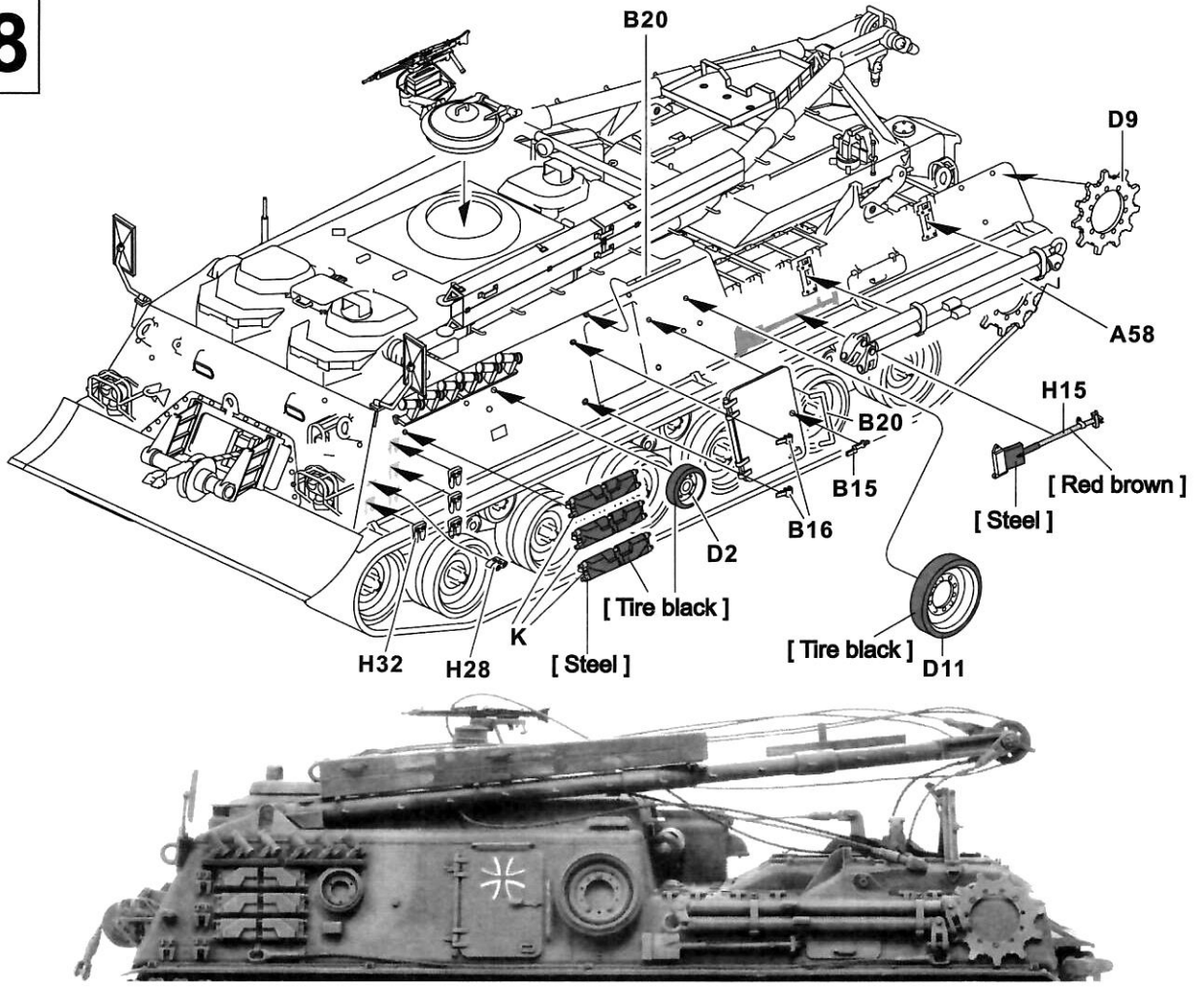

19

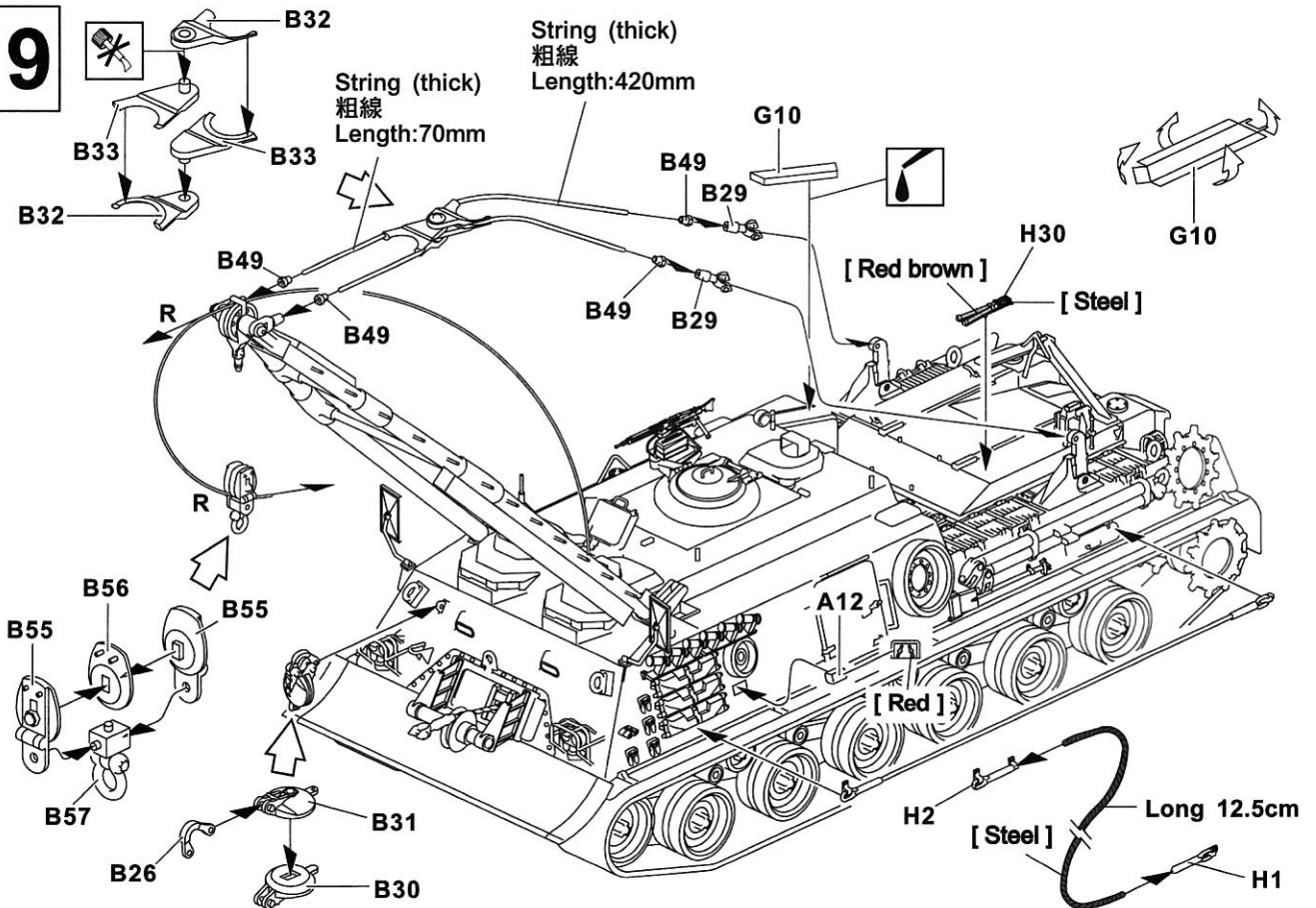

20

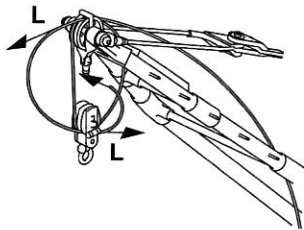
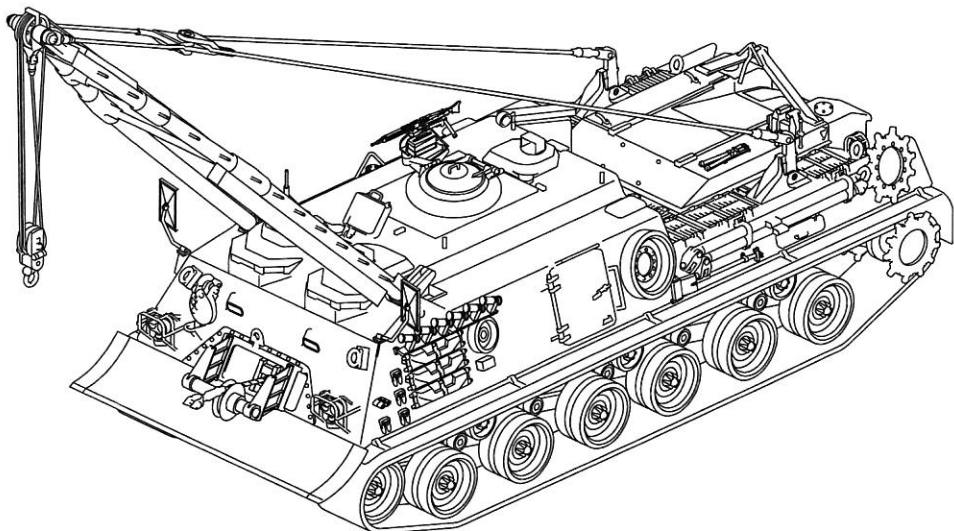
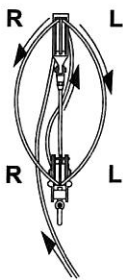

A  **Body Color:**  Tar black RAL 9021  Bronze green RAL 6031
 Leather brown RAL 8027

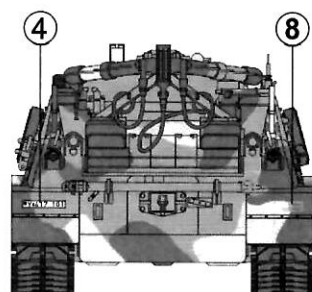
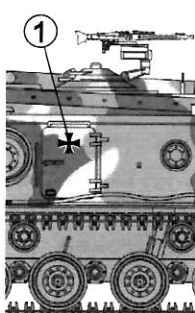
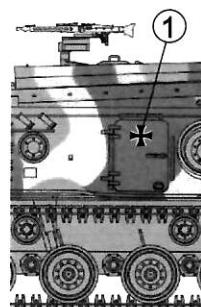
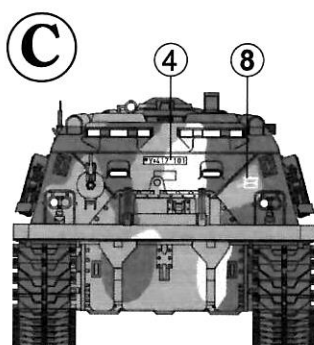
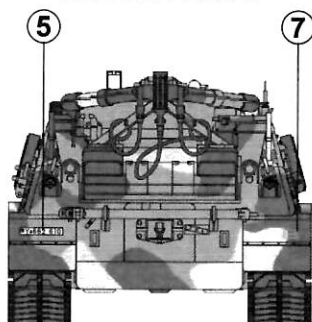
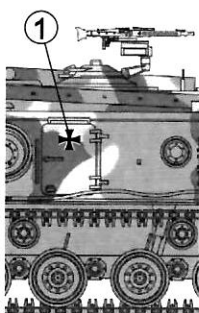
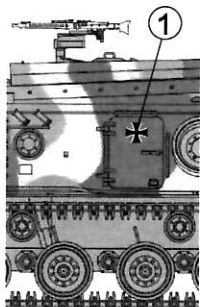
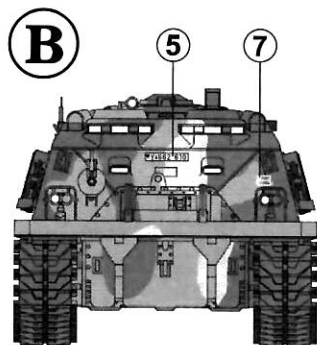
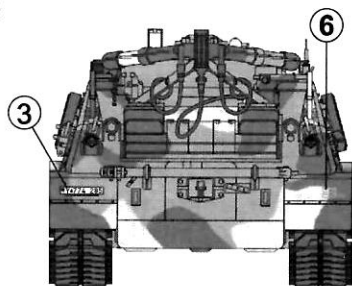
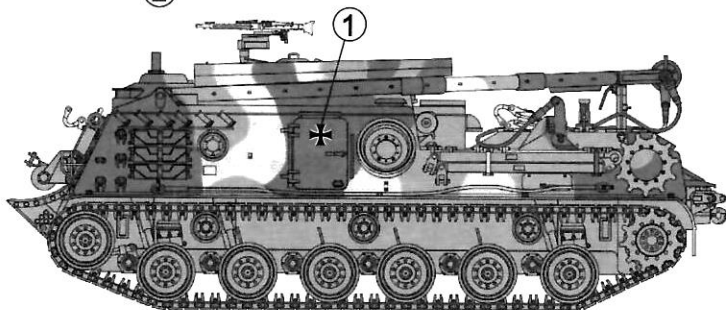
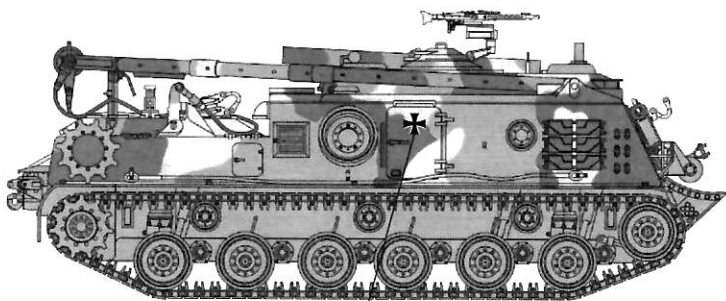
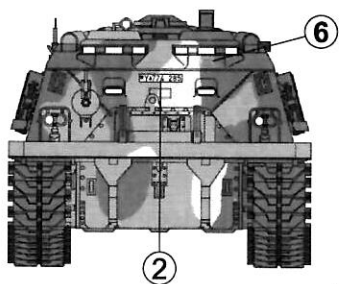

PARTS LIST 零件表

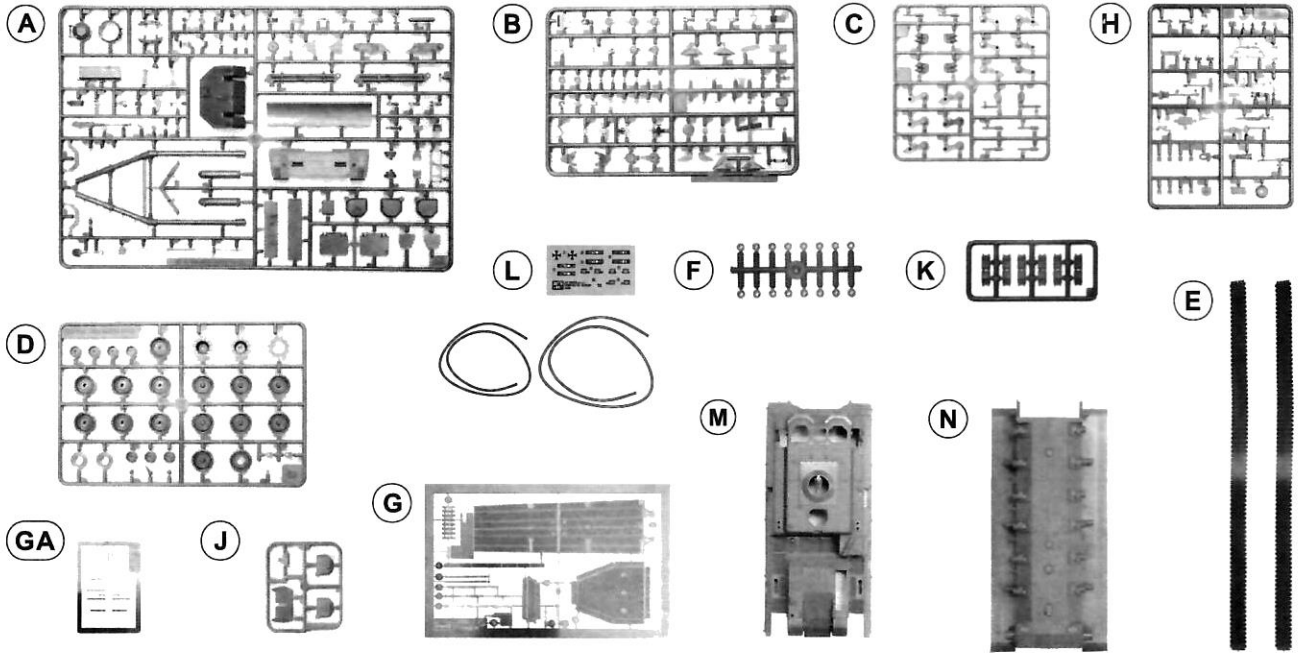

Parts :

- | | | | | |
|------------------|------------------|------------------|------------------|-------------------|
| A ————— 1 | D ————— 2 | H ————— 2 | L ————— 1 | GA ————— 1 |
| B ————— 2 | E ————— 1 | J ————— 1 | M ————— 1 | |
| C ————— 1 | G ————— 1 | K ————— 1 | N ————— 1 | |

Parts not used. A:9、10、18、19、20、21、25、39、40、41、45、61
 不需使用的零件 : 62、64、68、69、70、71、72、76、78、8
 B:1x2、26、28x2、30、31、46x2、49x4、51x2、52x2
 : 55x2、56、57
 J:2、3



Instructions:

If for some reason, you are not fully satisfied or have questions concerning our product; Please use the form provide, and send it to our nearest representative or mail it directly to our office.

We will deal with that A.S.A.P.



AF 35S33 Parts Replacement Form

- | | |
|----------------------------------|-----------------------------------|
| <input type="checkbox"/> A parts | <input type="checkbox"/> K parts |
| <input type="checkbox"/> B parts | <input type="checkbox"/> L parts |
| <input type="checkbox"/> C parts | <input type="checkbox"/> M parts |
| <input type="checkbox"/> D parts | <input type="checkbox"/> N parts |
| <input type="checkbox"/> E parts | <input type="checkbox"/> GA parts |
| <input type="checkbox"/> G parts | |
| <input type="checkbox"/> H parts | |
| <input type="checkbox"/> J parts | |

Reason for replacement: Missing
 Broken

Signature: _____

限臺灣地區使用 For Taiwanese use only!



AF 35S33

零件補充申請表

申請人
姓名 ..
地址 ..
電話 ..

- | | |
|----------------------------------|-------------|
| <input type="checkbox"/> A 部品零件 | —— NT\$ 200 |
| <input type="checkbox"/> B 部品零件 | —— NT\$ 260 |
| <input type="checkbox"/> C 部品零件 | —— NT\$ 200 |
| <input type="checkbox"/> D 部品零件 | —— NT\$ 260 |
| <input type="checkbox"/> E 部品零件 | —— NT\$ 200 |
| <input type="checkbox"/> G 部品零件 | —— NT\$ 260 |
| <input type="checkbox"/> H 部品零件 | —— NT\$ 200 |
| <input type="checkbox"/> J 部品零件 | —— NT\$ 160 |
| <input type="checkbox"/> K 部品零件 | —— NT\$ 80 |
| <input type="checkbox"/> L 部品零件 | —— NT\$ 80 |
| <input type="checkbox"/> M 部品零件 | —— NT\$ 180 |
| <input type="checkbox"/> N 部品零件 | —— NT\$ 180 |
| <input type="checkbox"/> GA 部品零件 | —— NT\$ 120 |

+ 郵寄費 ——— NT\$ 80

(請填) 總計 NT\$ _____

零件補充原因:(請於 打)

- 原包裝即 遺失或 毀損
 製作途中 遺失或 毀損
 補充多餘零件
 其他原因 _____

★請將本表與該部品相同金額之郵政匯票一同寄至
 總代理 戰鷹企業 客服部 收 本公司將盡速為您處理