

# The Mer su

ACD 48 021

Bf 109 G-2 & G-6 in The Finnish air force service

decal set - 9 marking options

1/48 decal set

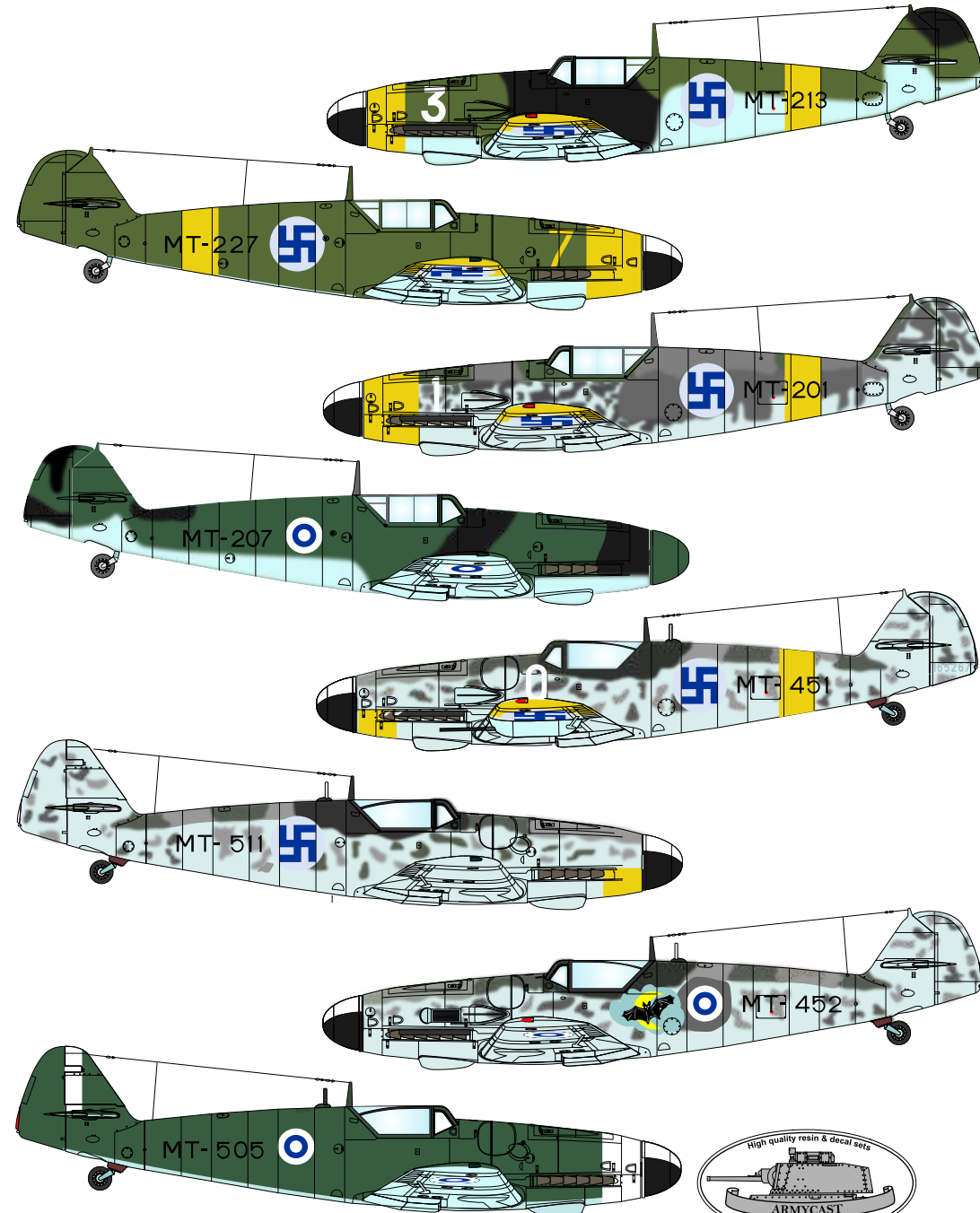

- Use warning symbols and stencils from the kit.
- Full stencils for schemes C, E, F, G, H only.
- Fuel filling marking without stencils for schemes A, B, D only.

## Used colours:

GUNZE SANGYO  
Mr. COLOR

A		SEMIGLOSS BLACK	C 092
B		RLM 74	C 036
C		RLM 75	C 037
D		RLM 76	C 117
E		LIGHT BLUE (RLM 65) + overpaint Hakaristy + yellow marking	C 115
F		YELLOW RLM 02	C 113
G		GREEN	C 122
H		OLIVE GREEN	C 120
I		RLM 66	C 116
J		RLM 75 fresh overpaint LWF cross	C 037
K		DARK GREY overpaint Hakaristy	C 032
L		WHITE	C 001

Recommended kit: **Eduard**

[www.armycast.cz](http://www.armycast.cz)

Printed in  
the Czech Republic  
© Armycast, 2017

[www.armycast.cz](http://www.armycast.cz)

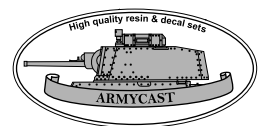

© Armycast, 2017

**A** Bf 109 G-2, W.Nr. 14754, MT-213, 2/HLeLv 24, Finnish AF, May 1944, pilot Lieutenant E.Riihikailio.

Total score of this Bf 109G-2 was 10 victories.

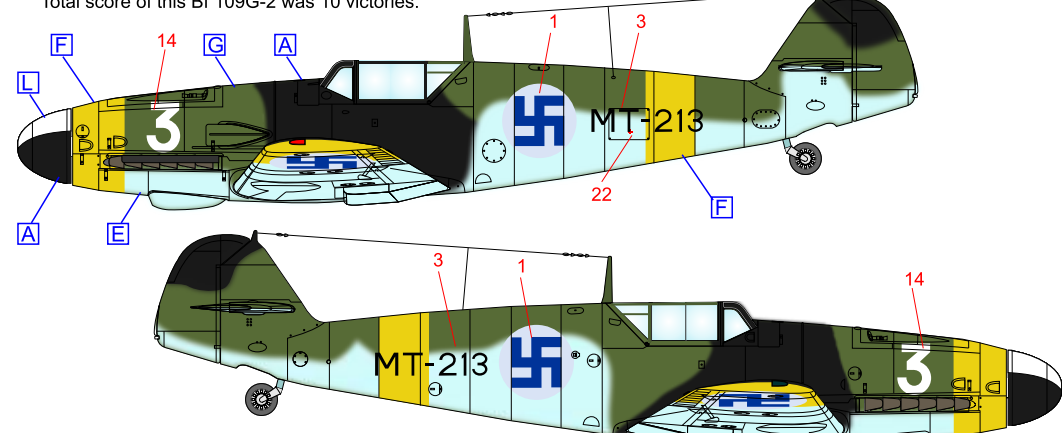

**B** Bf 109 G-2, W.Nr. 13736, MT-227, 2/HLeLv 24, Finnish AF, May 1944, Sulajärvi airfield, pilot Lieutenant U.Sarjamo.

Total score of this Bf 109G-2 was 9 victories.

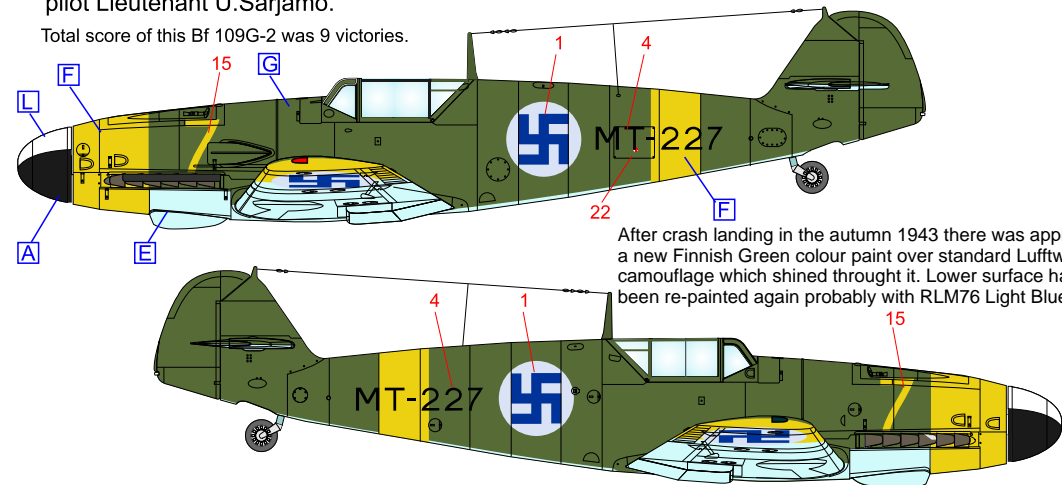

After crash landing in the autumn 1943 there was applied a new Finnish Green colour paint over standard Luftwaffe camouflage which shined through it. Lower surface has been re-painted again probably with RLM76 Light Blue.

**C** Bf 109 G-2, W.Nr. 14718, MT-201, 2/LeLv 34, May 1944

Total score of this the Best Finnish Bf 109G-2 was 32,5 victories.

Early the service digit 1 (decal no.16) was not applied.

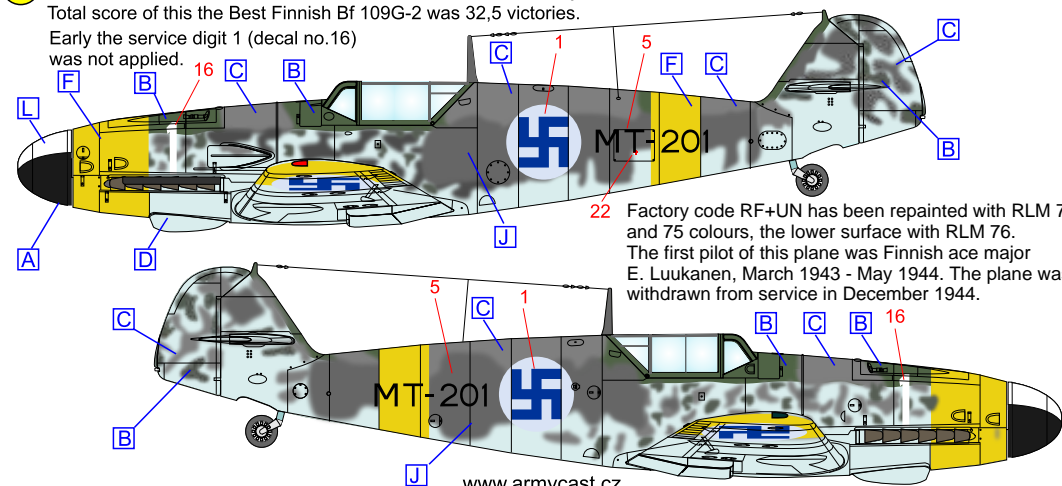

Factory code RF+UN has been repainted with RLM 74 and 75 colours, the lower surface with RLM 76. The first pilot of this plane was Finnish ace major E. Luukonen, March 1943 - May 1944. The plane was withdrawn from service in December 1944.

**G**

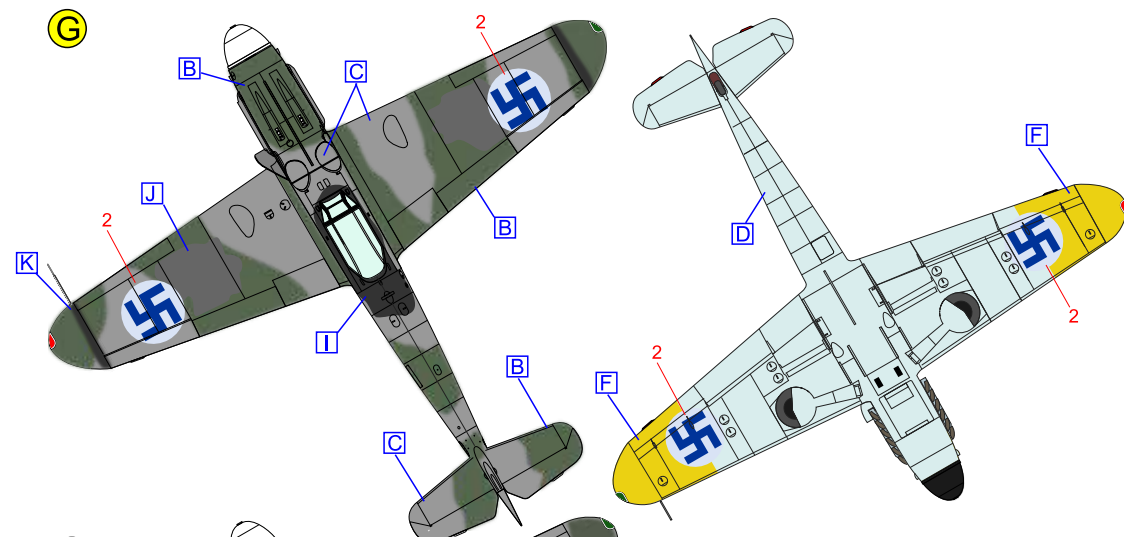

**H**

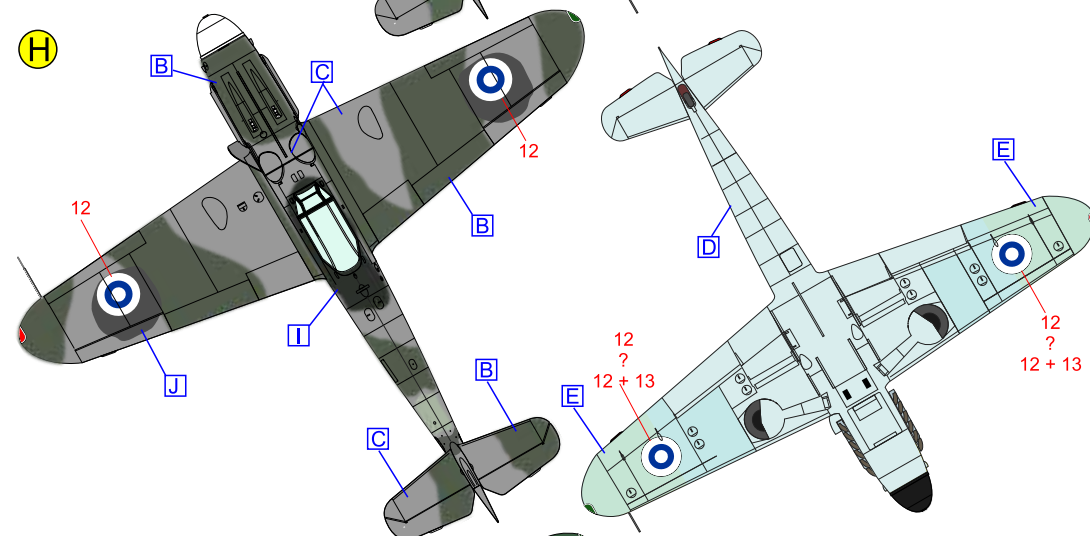

**I**

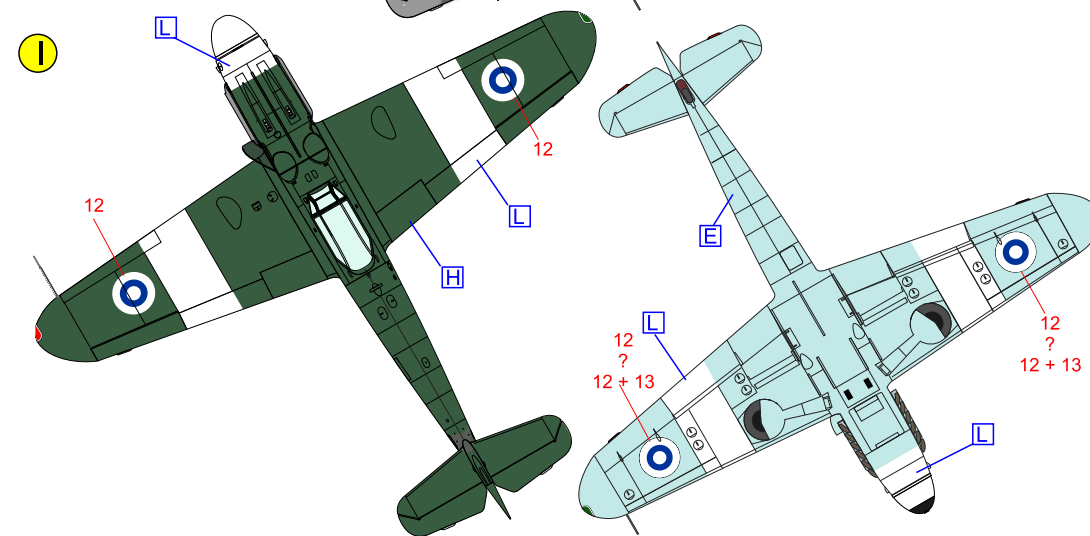

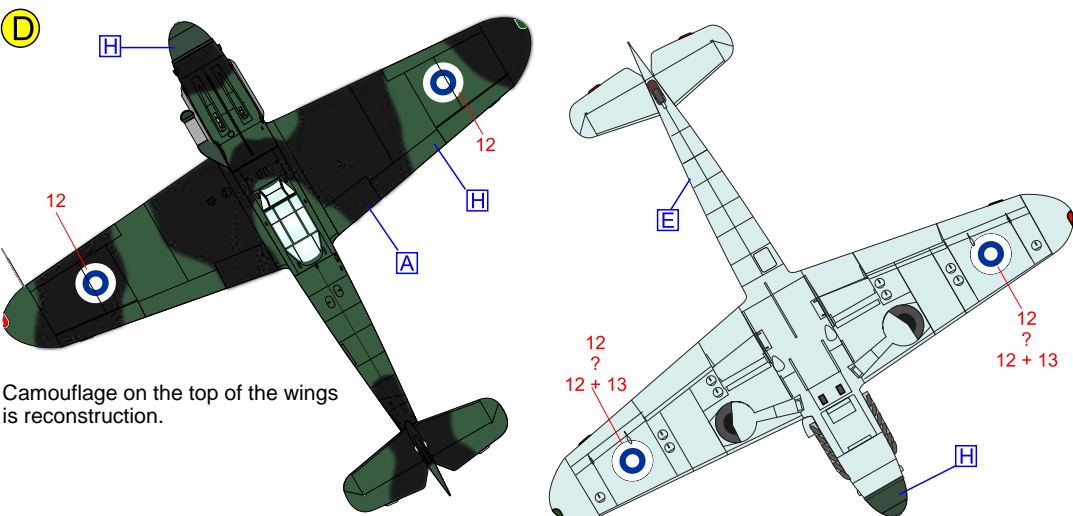

Camouflage on the top of the wings is reconstruction.

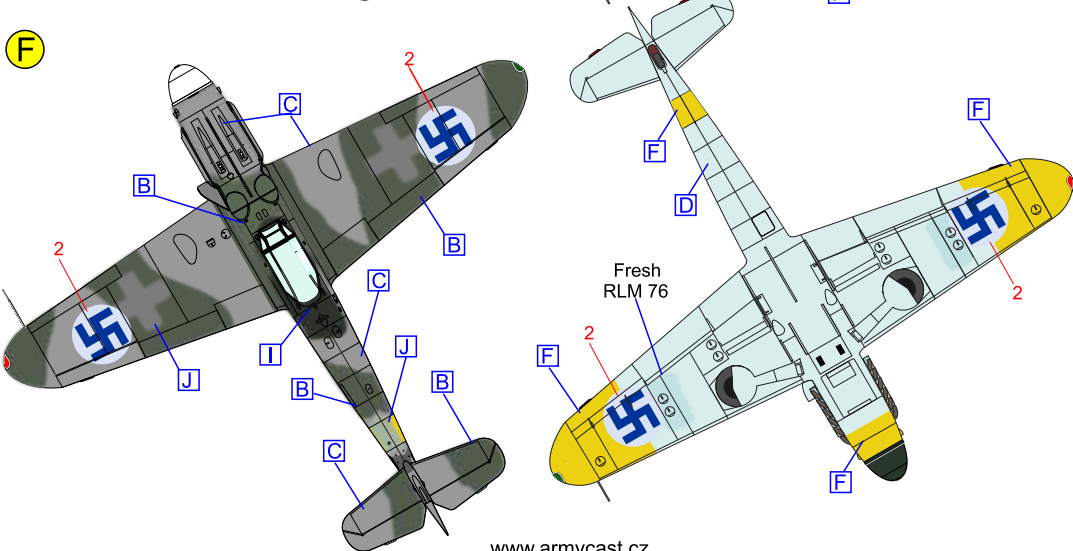
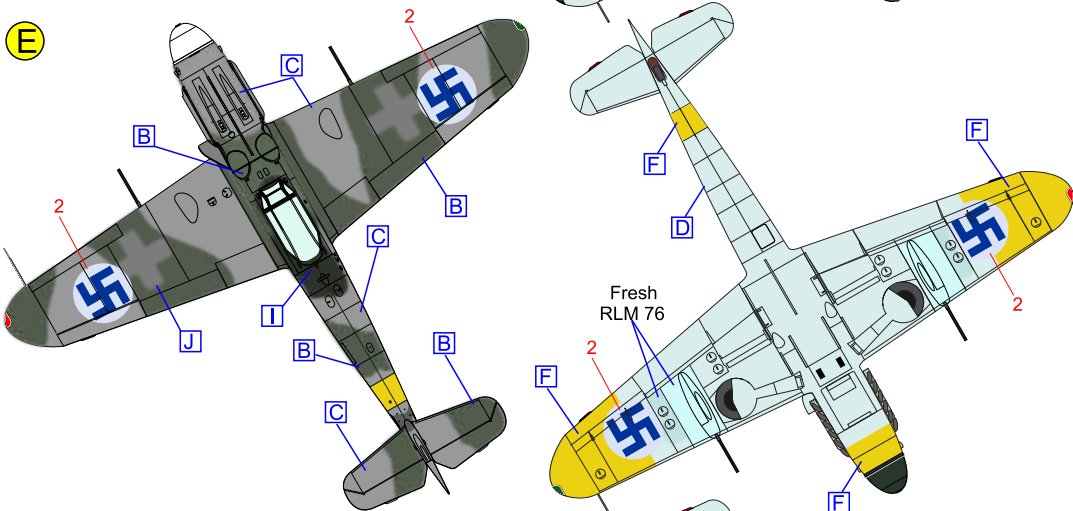

**D** Bf 109 G-2, W.Nr.14741, MT-207, HLeLv 11, Finnish AF, 1946  
Total score of this Bf 109G-2 was 5 victories.

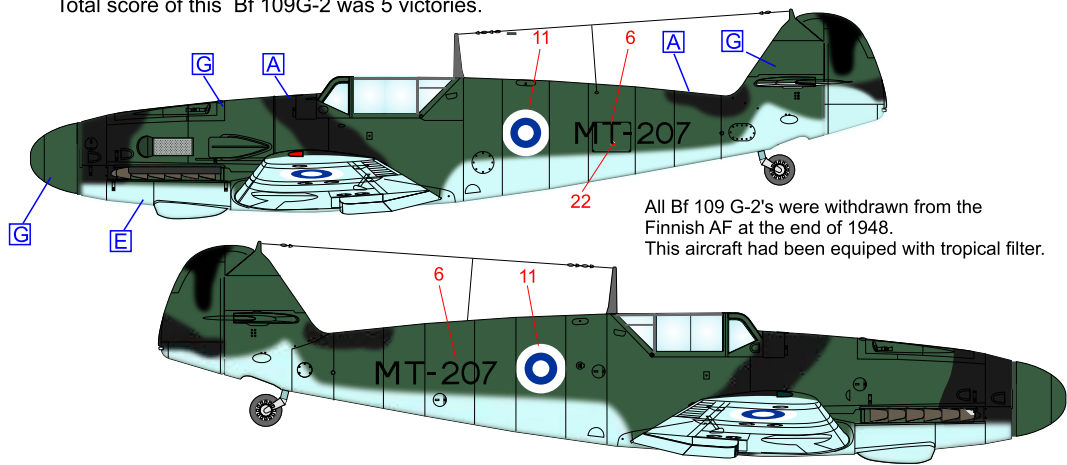

All Bf 109 G-2's were withdrawn from the Finnish AF at the end of 1948. This aircraft had been equipped with tropical filter.

**E** Bf 109 G-6/R6, Ltm. Juutilainen, W.Nr.165267, MT-451, 1/HLeLv 34, Tailpalsaary airfield, Finnish AF, June 1944

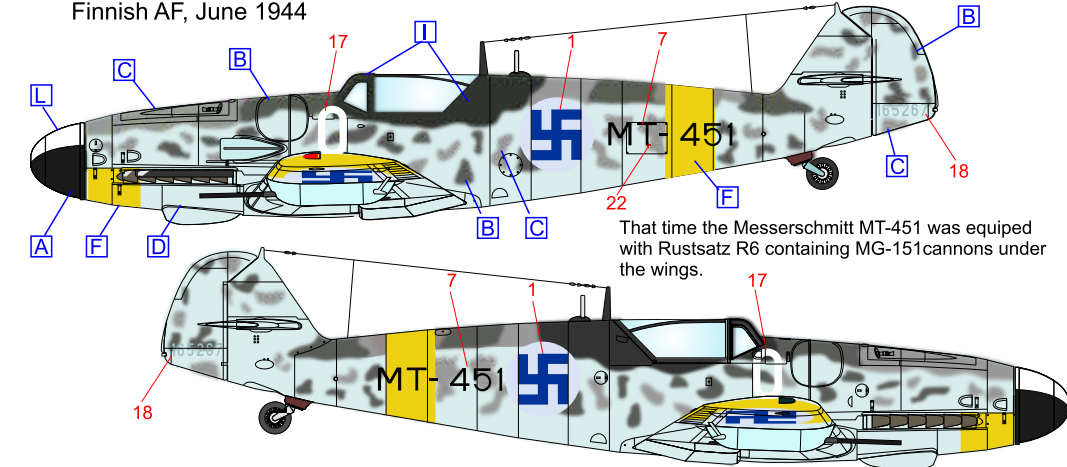

That time the Messerschmitt MT-451 was equipped with Rustsatz R6 containing MG-151 cannons under the wings.

**F** Bf 109 G-6 Ltm. Juutilainen, W.Nr.165267, MT-451,1/HLeLv 34, Finnish AF, August 1944.  
Total score of this Bf 109G-6 was 1 victories.

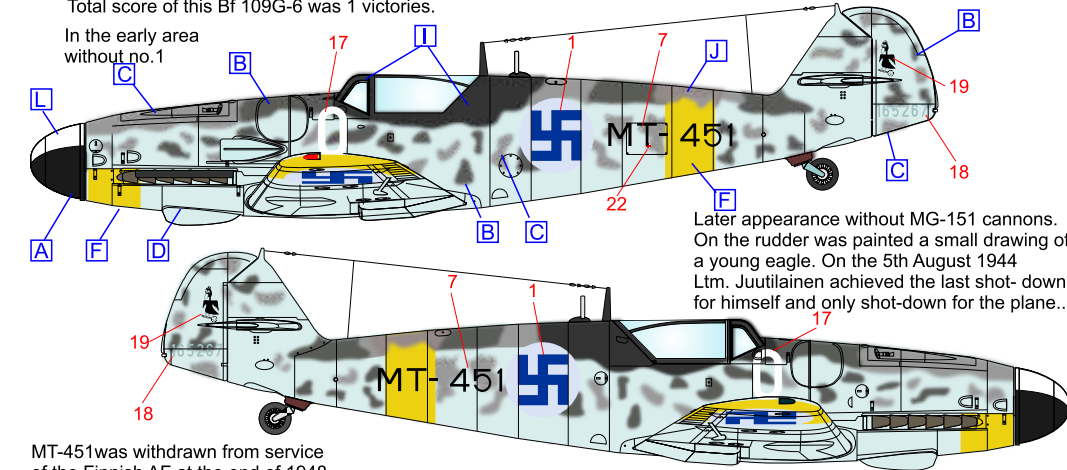

Later appearance without MG-151 cannons. On the rudder was painted a small drawing of a young eagle. On the 5th August 1944 Ltm. Juutilainen achieved the last shot-down for himself and only shot-down for the plane..

MT-451 was withdrawn from service of the Finnish AF at the end of 1948.

**G** Bf 109 G-6, W.Nr.165429, MT-511,1/HLeLv 34, Finnish AF, August 1944.  
The plane used tropical filter.

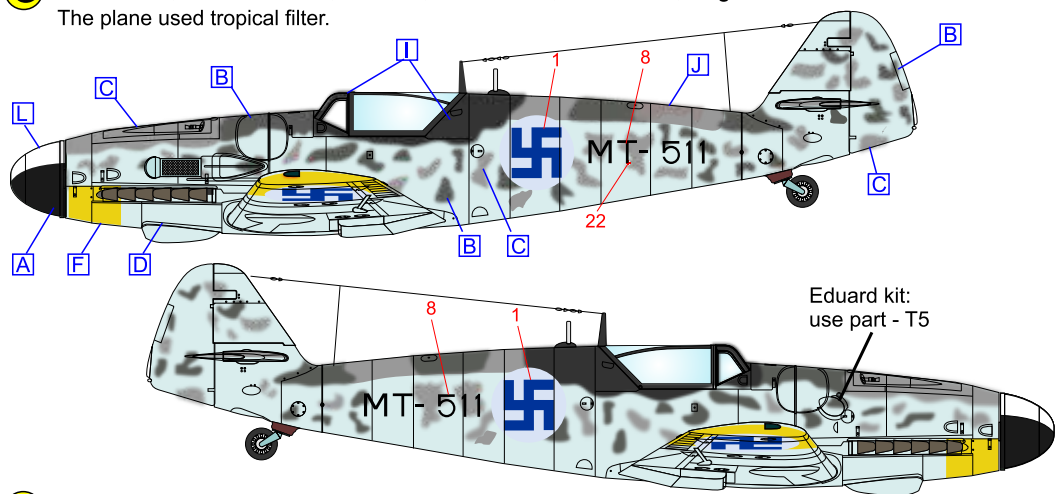

**H** Bf 109 G-6 (Erla canopy), Sergant E.Aromaa, W.Nr.165227, MT-452, HLeLv 31, Finnish AF, early 1950s. The plane very probably used tropical filter.  
Total score of this Bf 109G-6 was 9 victories.

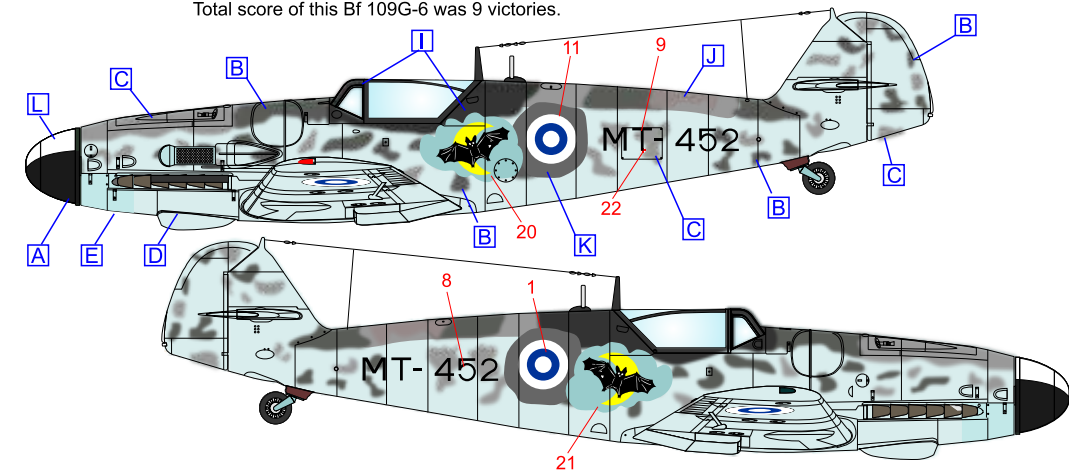

**I** Bf 109 G-6 (Erla canopy), W.Nr.1662215 MT-505, PLeLv 41, Finnish AF, 1948 - 50.  
The plane used tropical filter.

