

INTRUDER A-6E

A-6E イントルーダー 艦上攻撃機

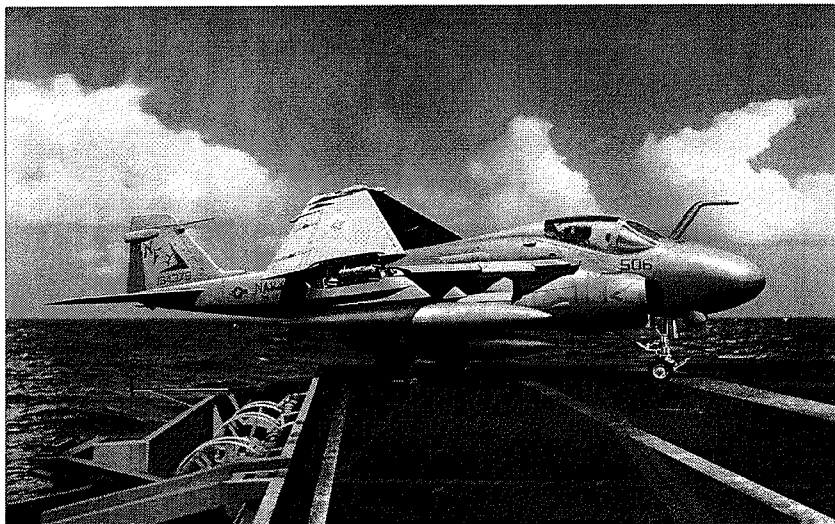

1/48 A-6E Intruder

The carrier based A-6E intruder is a variant of the A-6 series which had been the mainstay of the U.S. Navy and U.S. Marine Corps from 1963 to 1997. As the last member in the series, the A-6E was introduced in 1970 and featured vast improvements on the radar system and onboard computer for missions including close air support, interdiction and deep-strike missions.

Despite the nickname "Double Ugly" inspired by its large blunt nose, the A-6E was obviously a top performer attack bomber. It had a total payload of 18,000 pounds and was capable of carrying ordnance including HARM, Harpoon missiles and a wide range of air-to-ground weapons. With the large variety of ordnance, the multiple-mode radar and Forward Looking Infra-Red (FLIR) system, the A-6E was able to detect, identify and attack targets precisely under zero-visibility conditions or in foul weather. In the early 1990s, wing fatigue problems were discovered in the A-6Es. As a primary solution, majority of the fleets were fitted with upgraded composite wings which significantly extended the aircrafts' operational life.

The A-6E saw service extensively in Operation El Dorado Canyon, Operation Desert Storm, Operation Restore and in Bosnia. As the aircraft retired in 1997, its precision strike role was filled by the F-14 Tomcat.



Drill



Remove



2 Set



Bend



Optional



Decal



Super Glue



Fill Hole



No Cement



Ballast

Tools Recommended 使用する工具

Cement

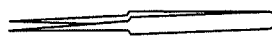
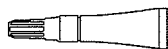

Tweezers

Side Cutter



Modeling Knife

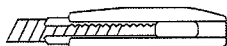

PAINTING GUIDE

MR. COLOR

HOBBY COLOR

VALLEJO (MODEL COLOR)

White	1	H1	842
Black	2	H2	861
Gray	308	H308	989
Olive Green	120		974
White	316	H316	842
Red	327	H327	947
Clear Red	47	H47	
Clear Green	138	H138	
Gray FS 36320	307	H307	905
Light Gray FS 36375	308	H308	990
Yellow FS 13538	329	H329	

* 316 denotes GSI Mr. Color

1/48 SCALE AIRCRAFT SERIES NO:48023

CAUTION

- *Read carefully and fully understand the instructions before commencing assembly.
- *Keep out of reach of children. Children must not be allowed to put any parts in their mouths, or pull plastic bag over their heads.
- *When using adhesives and paints, please make sure not to use them in closed room or near the fire.
- *When assembling this kit, tools including knives are used. Extra care should be taken to avoid injury.

WARNING: CONTAIN SMALL PARTS NOT FOR CHILDREN UNDER 14 YEARS OF AGE.

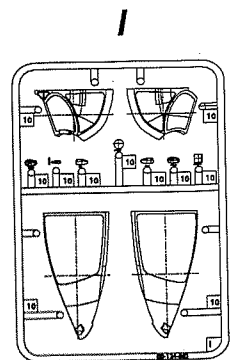
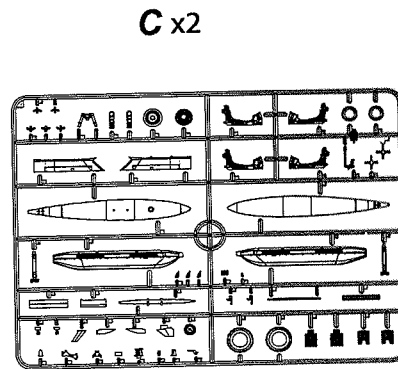
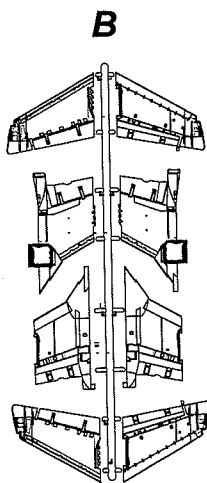
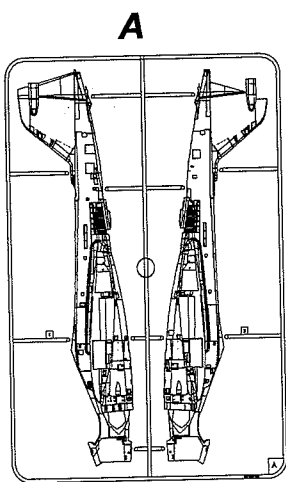

**Weapon Set A X 2
MK82**

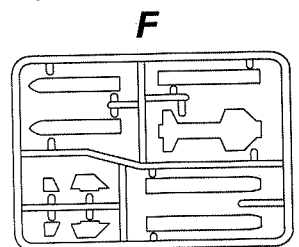
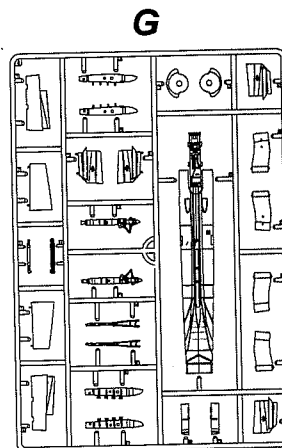
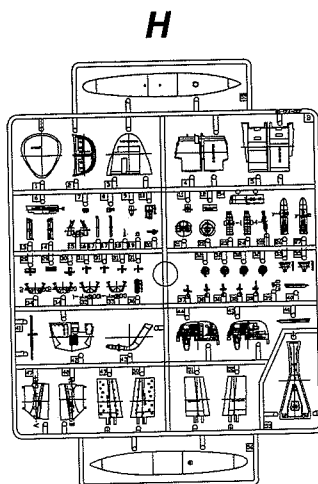
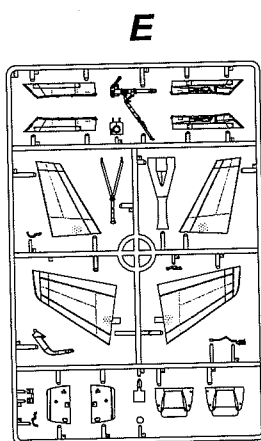
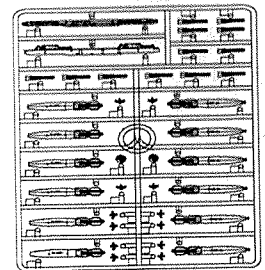

AFTERMARKET SERVICES CARD

When requesting replacement parts, please take or send this form to your local dealer so that the parts required can be correctly identified. Please note that specifications and availability are subject to change without notice.

For more information, please contact services@kineticmodel.com or visit <http://www.kineticmodel.com> for latest information.

Parts Code	Item 48023
00-124-001.....	A part
00-105-002.....	B part
00-105-003.....	C part
00-124-003.....	I part
00-105-005.....	E part
00-105-007.....	G part
00-124-002.....	H part
00-103-009.....	F part
00-124-48023.....	A-6E decal
01-143-001.....	Weapon Set A X 2
03-124-48023.....	Manual

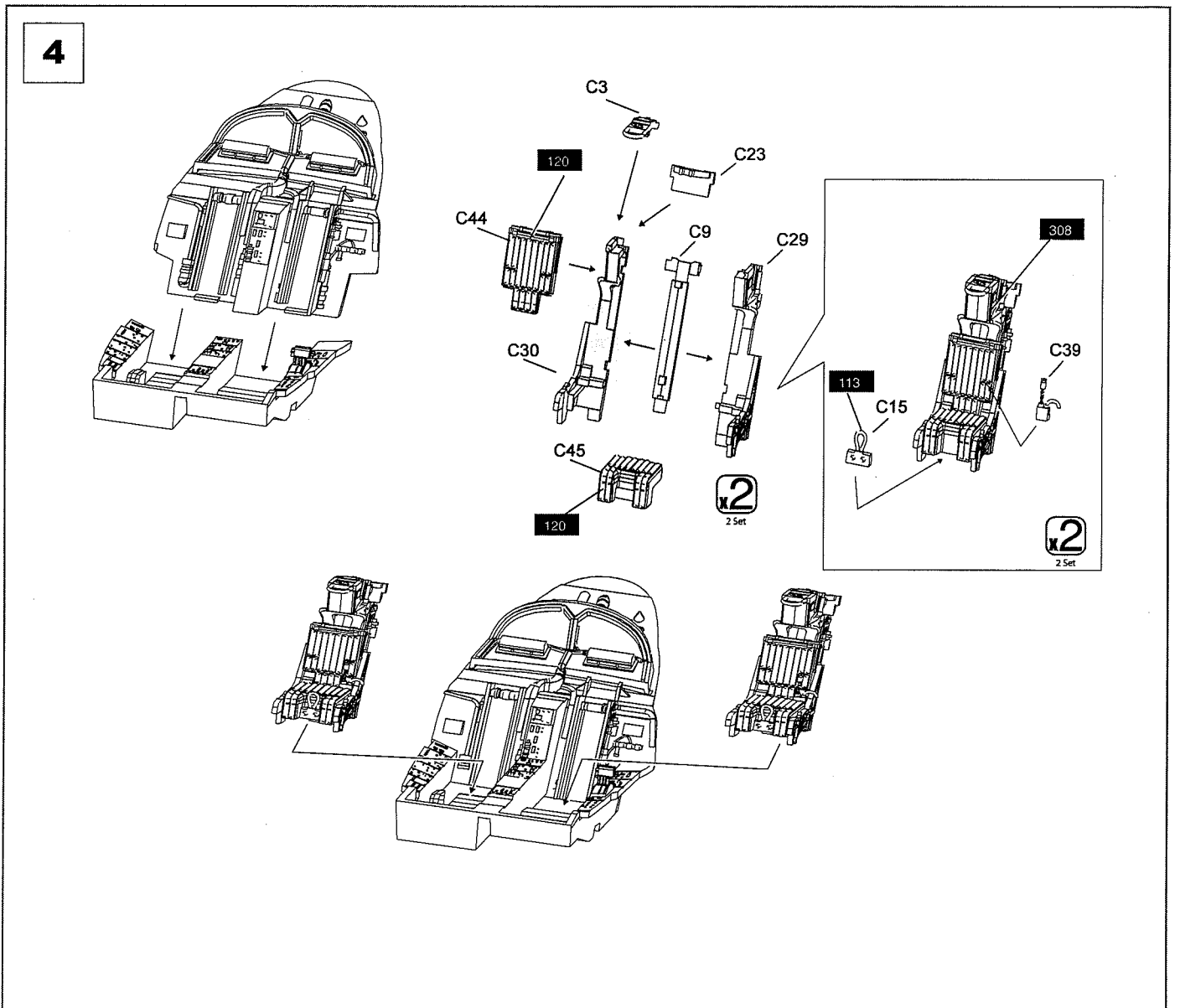
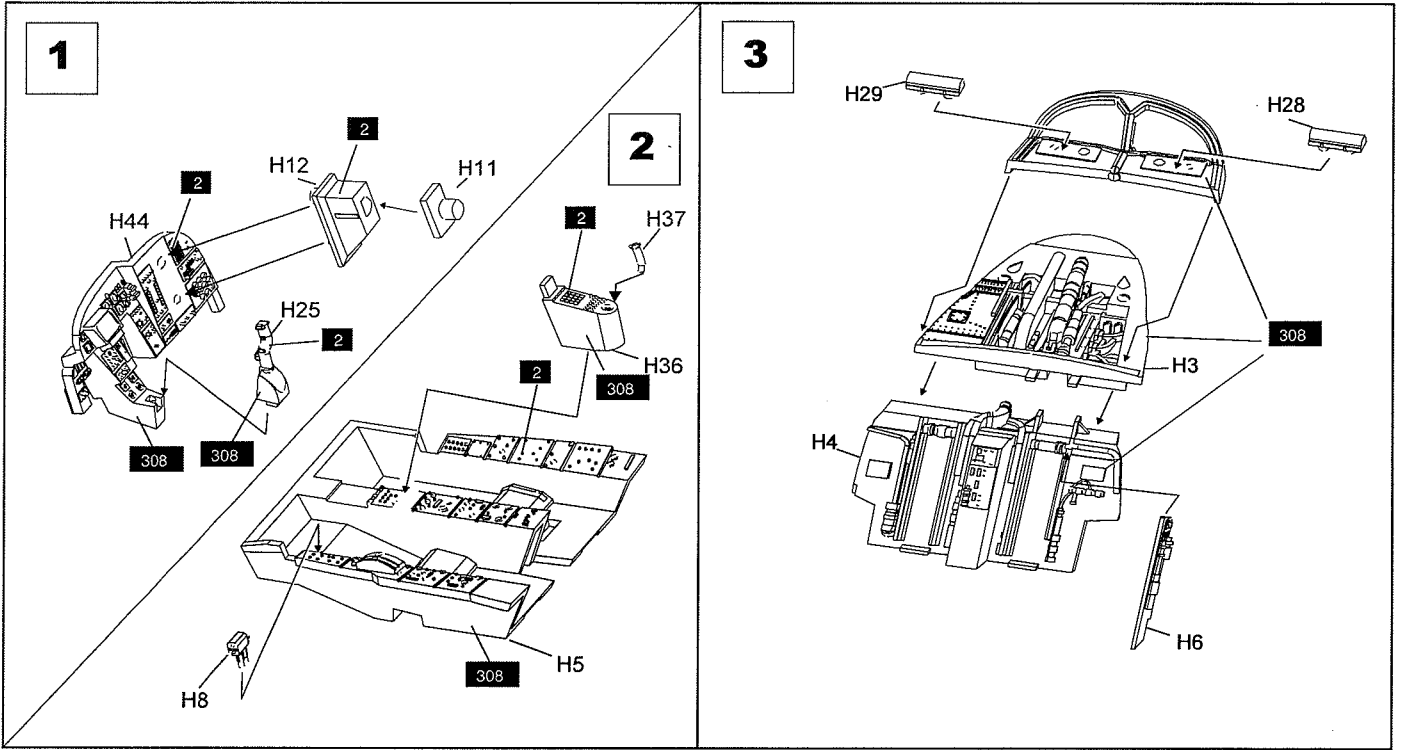

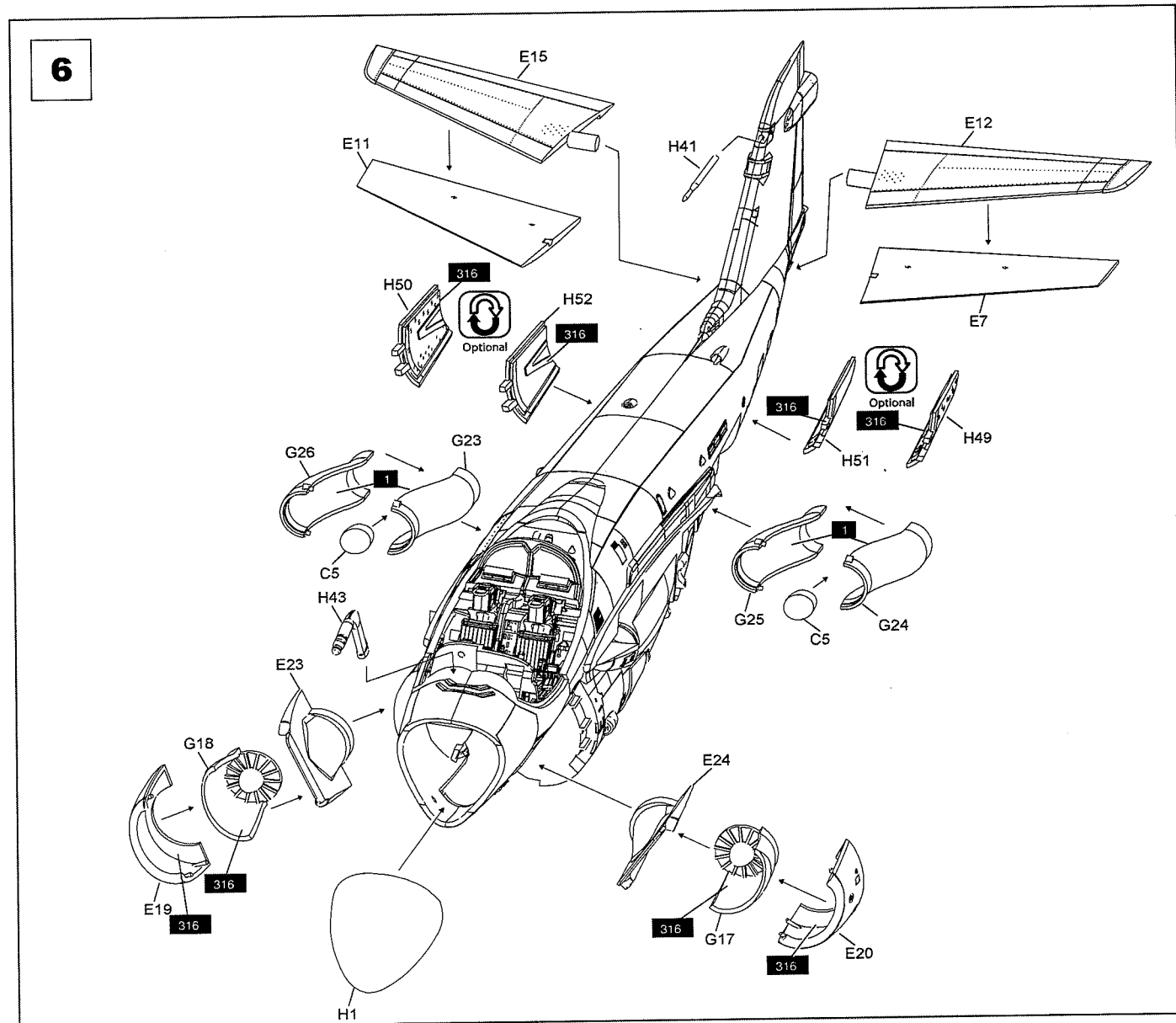
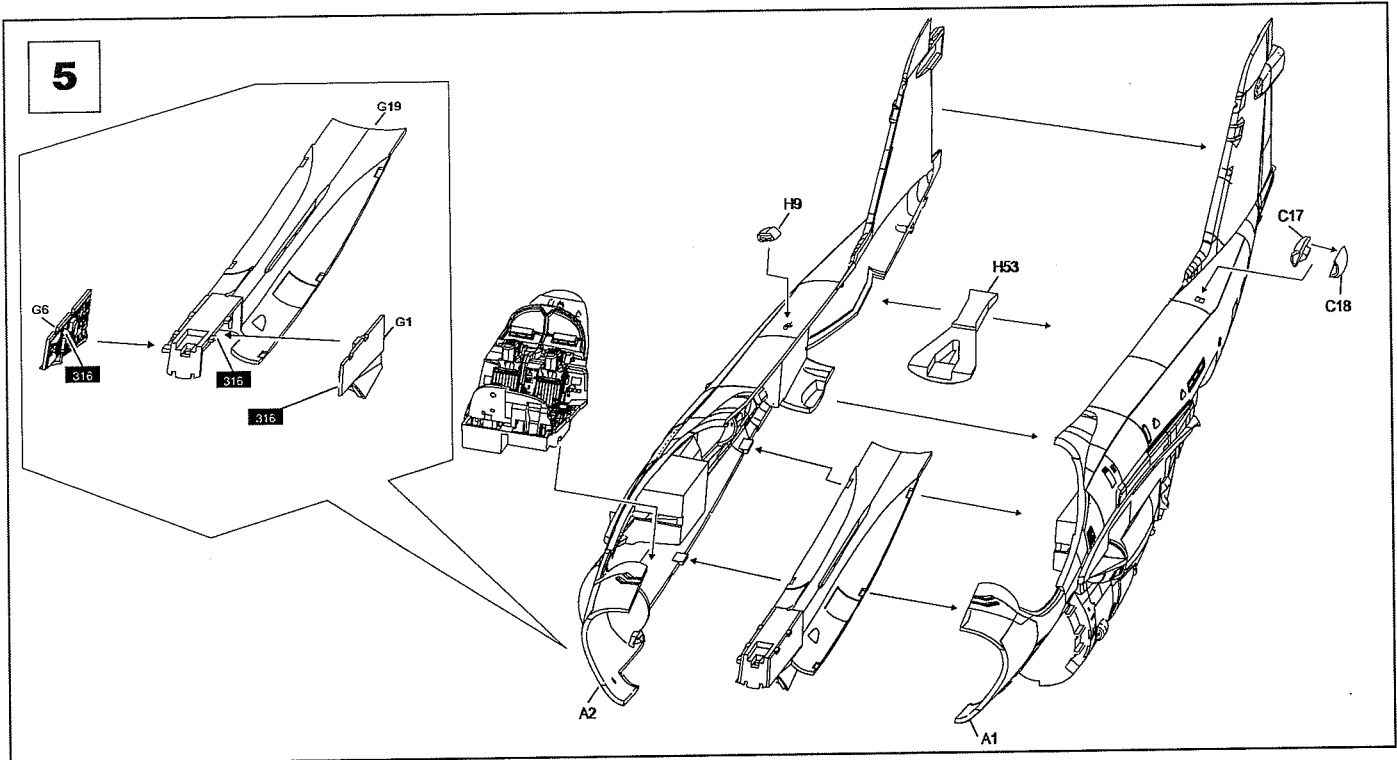

7

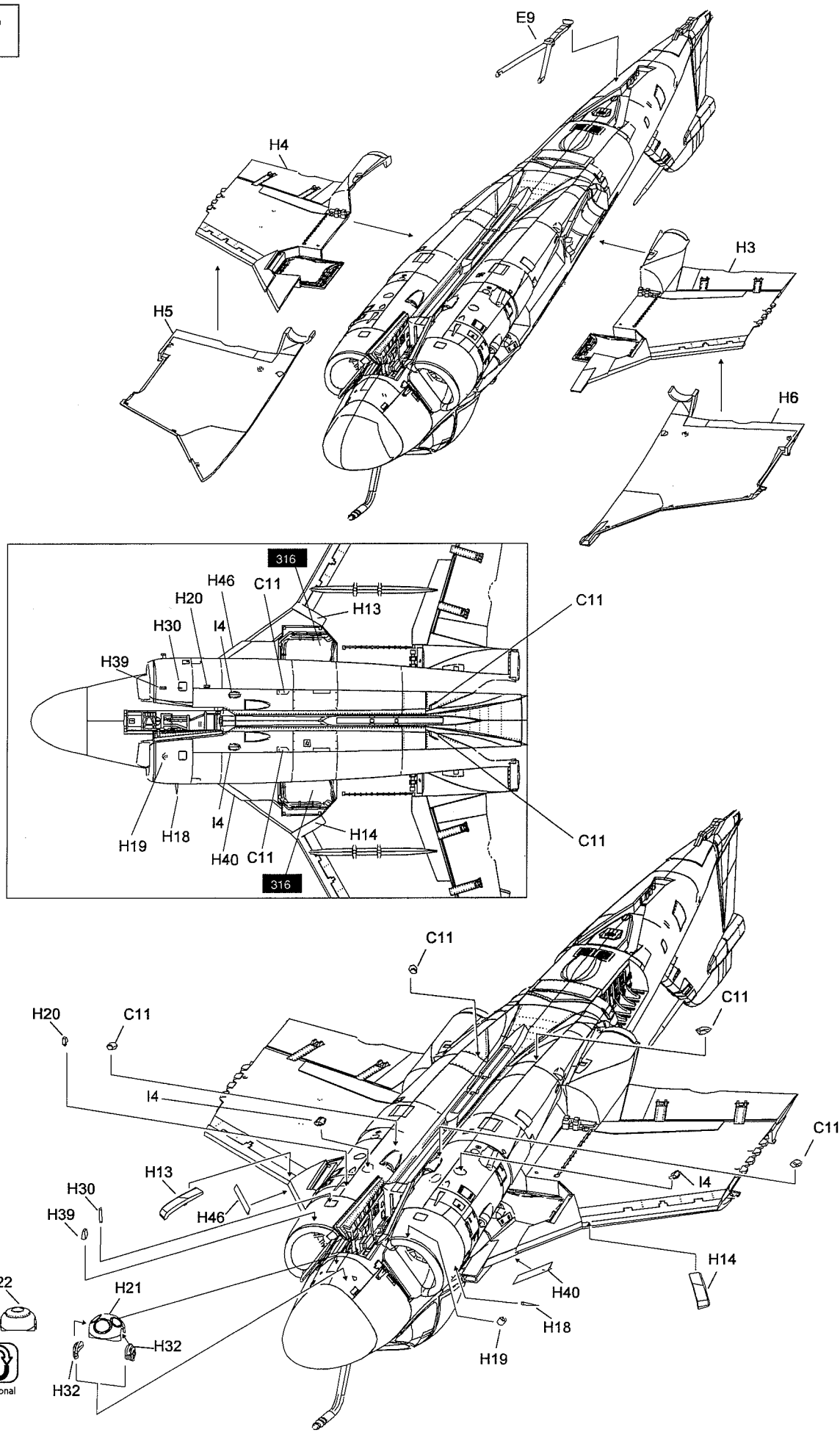

P5

8

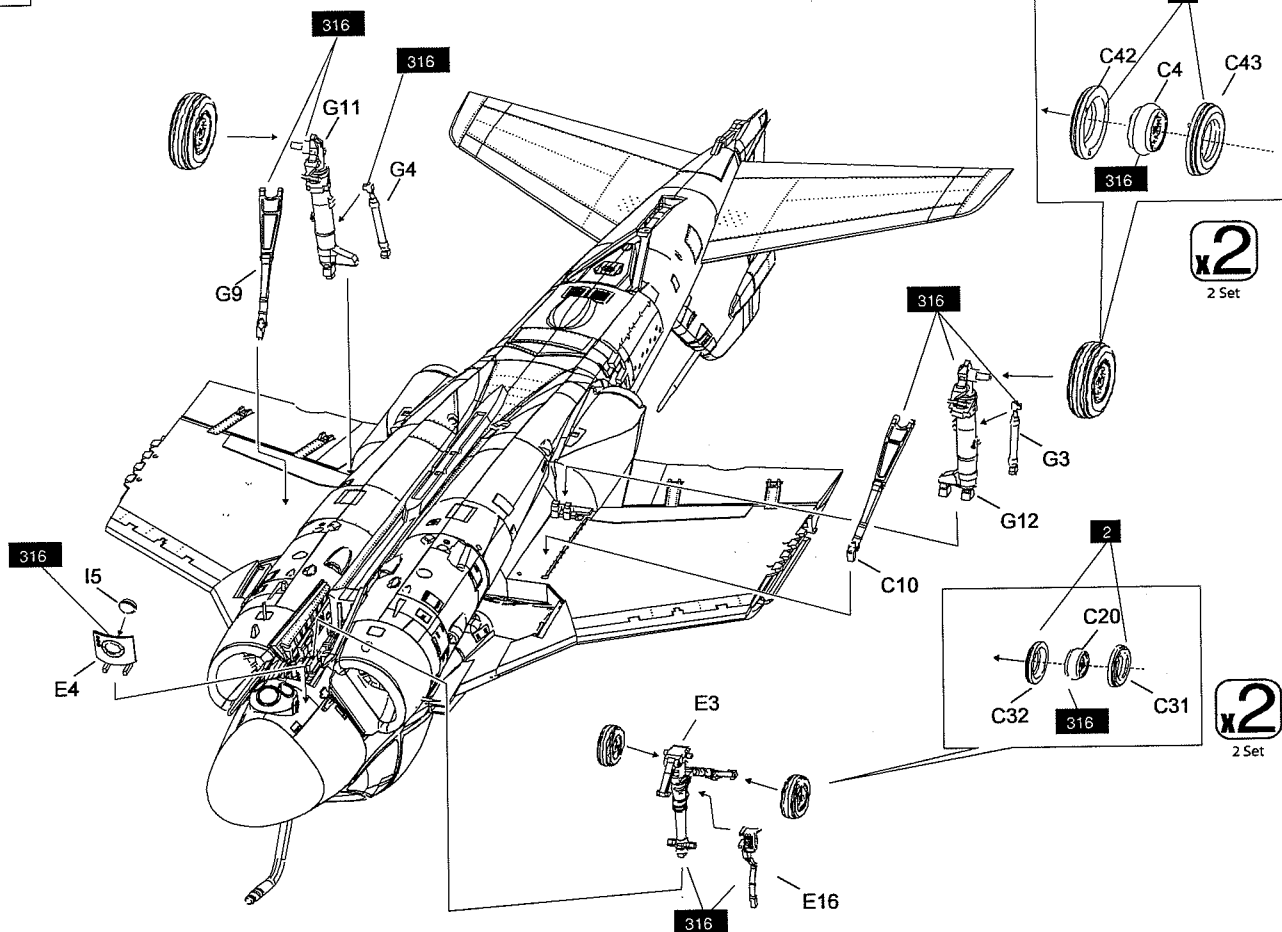

9

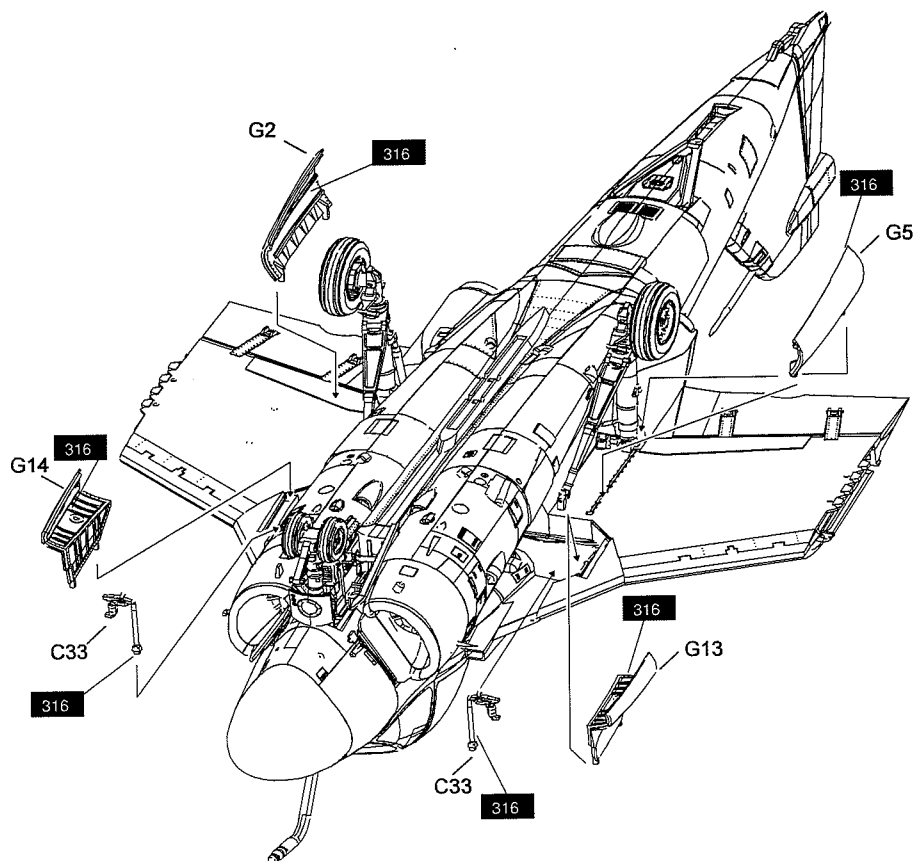

10

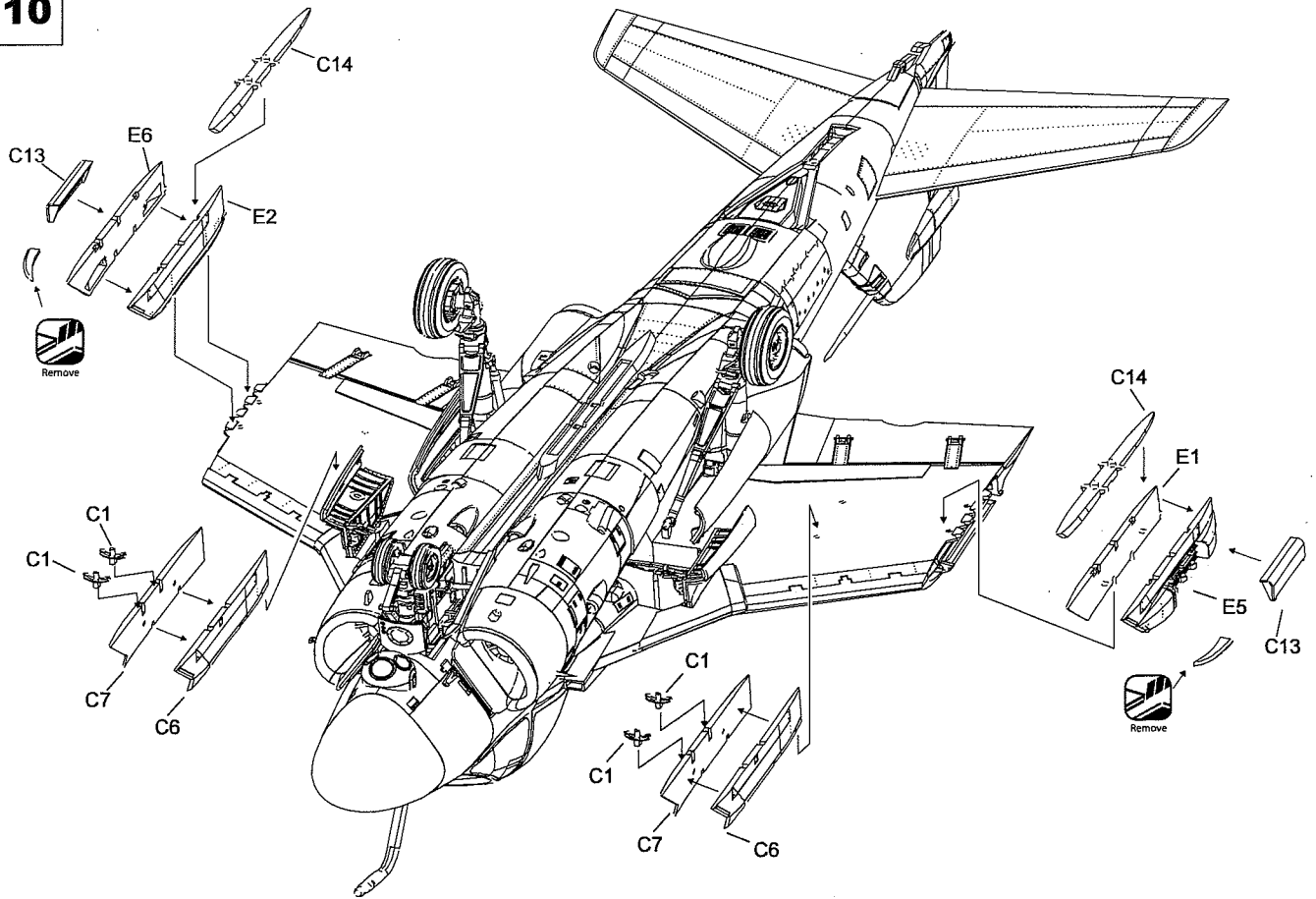

11

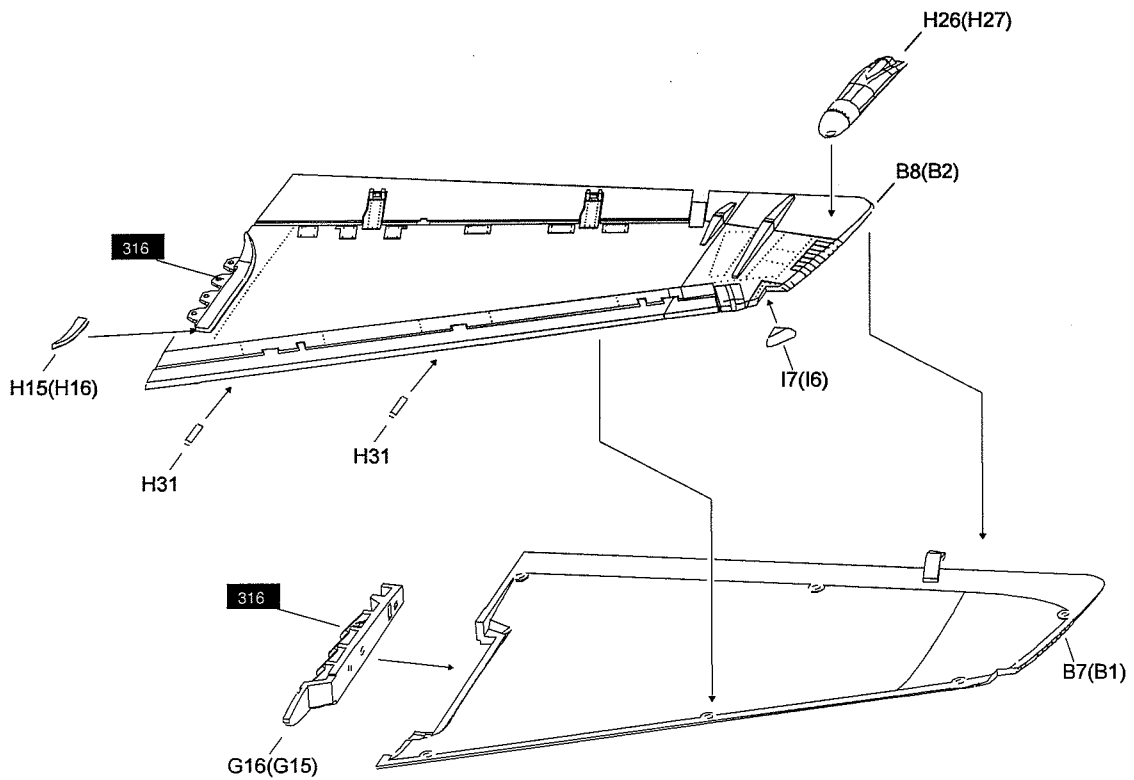

12

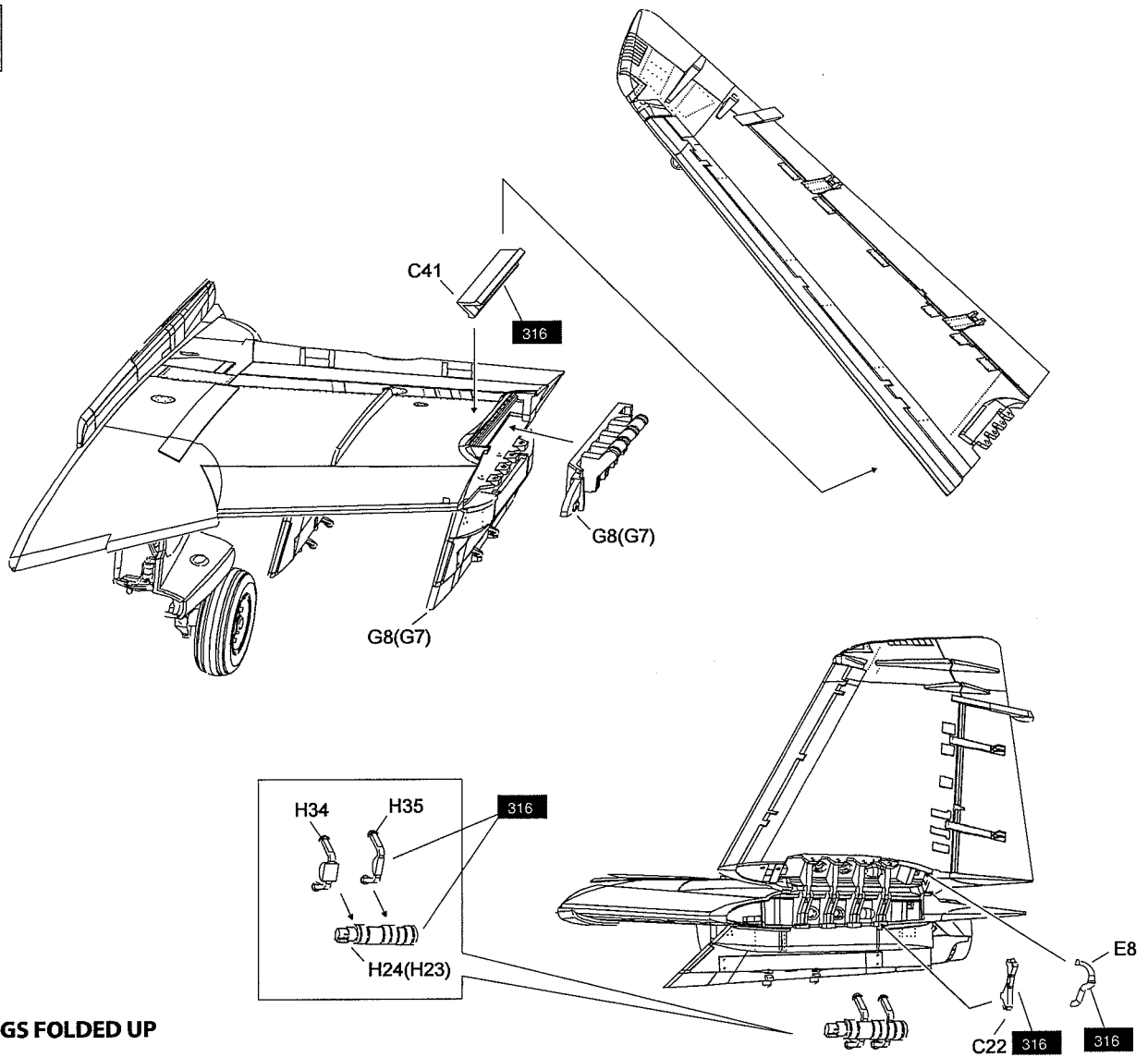

WINGS FOLDED UP

13

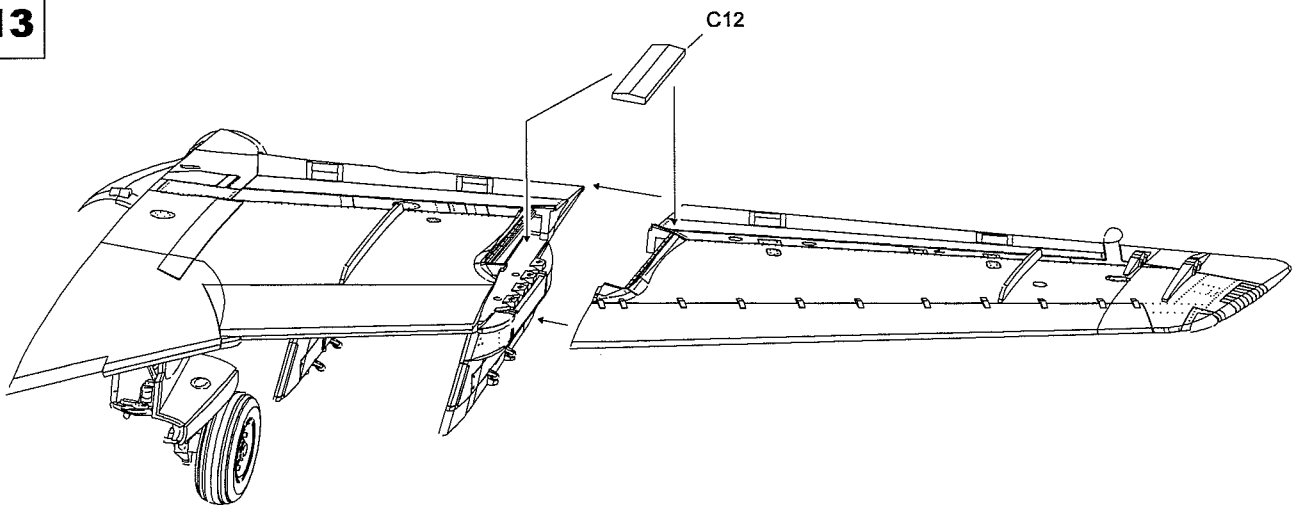

WINGS EXTENDED

14

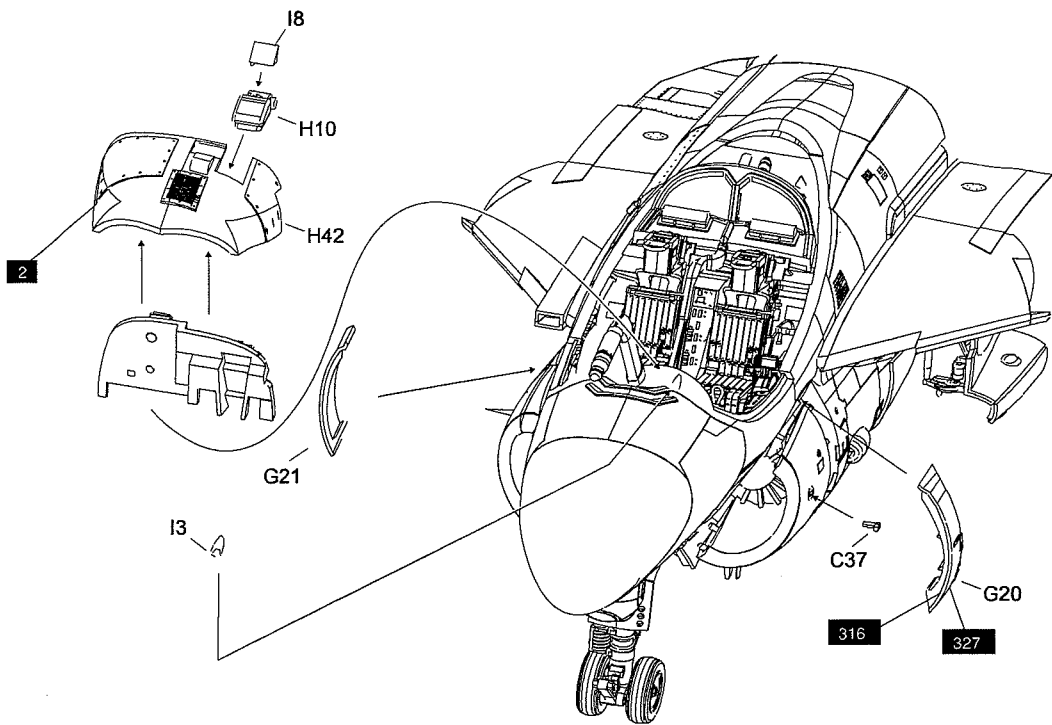

15

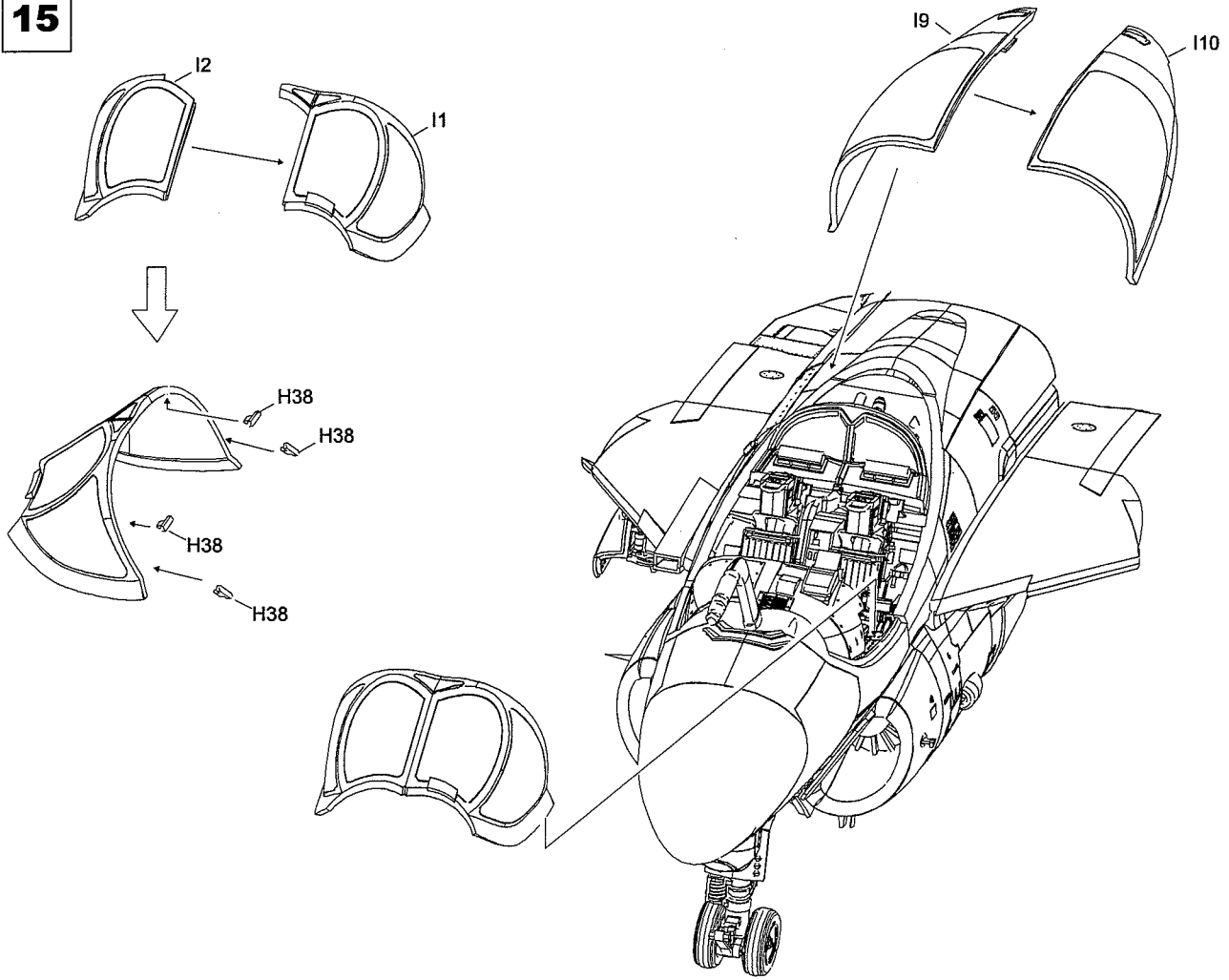

16

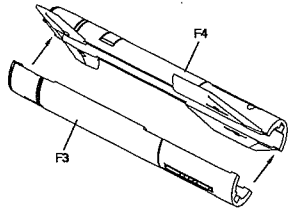

AGM - 84D HARPOON

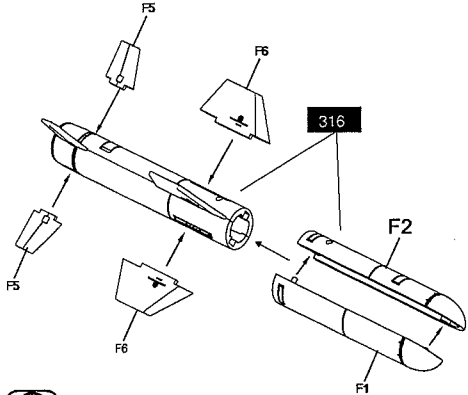

Optional

WEAPON SET A
MK82

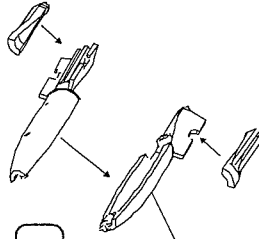

12
12 Set

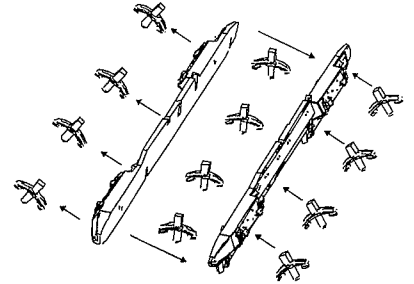

2
2 Set

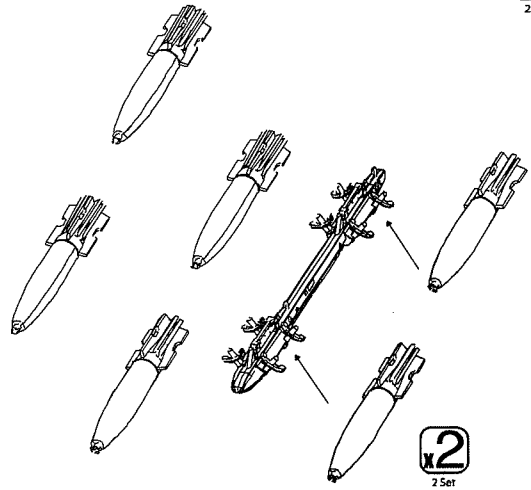

2
2 Set

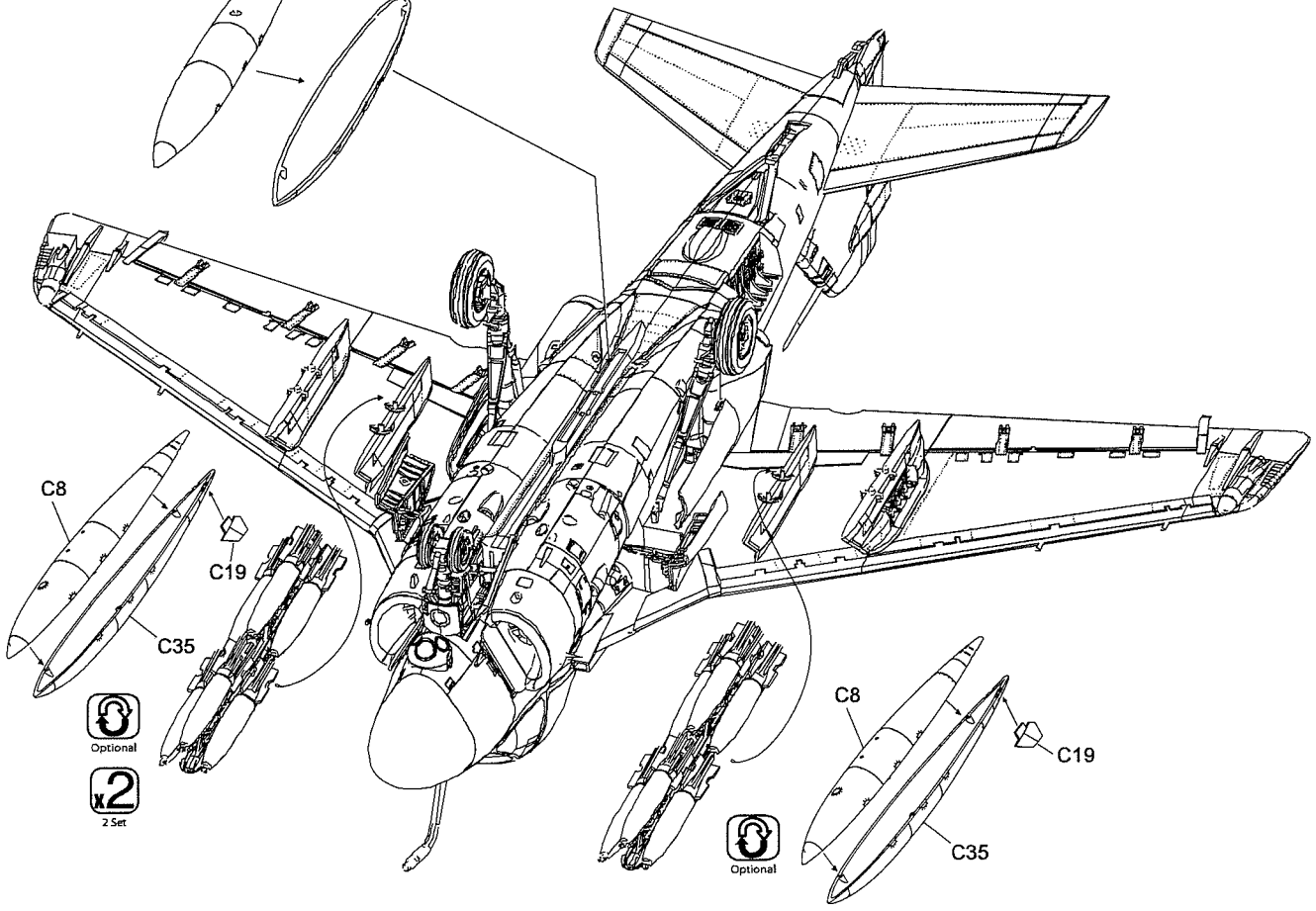
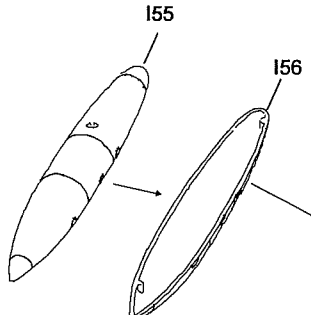

Optional

2
2 Set



Optional

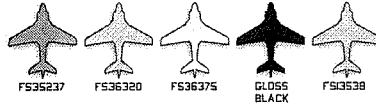

GRUMMAN A-6E
VA-115 EAGLES
BUND 155622
AUG-OCT 1996

LT JOHN DUNNE
[CHOWDA]

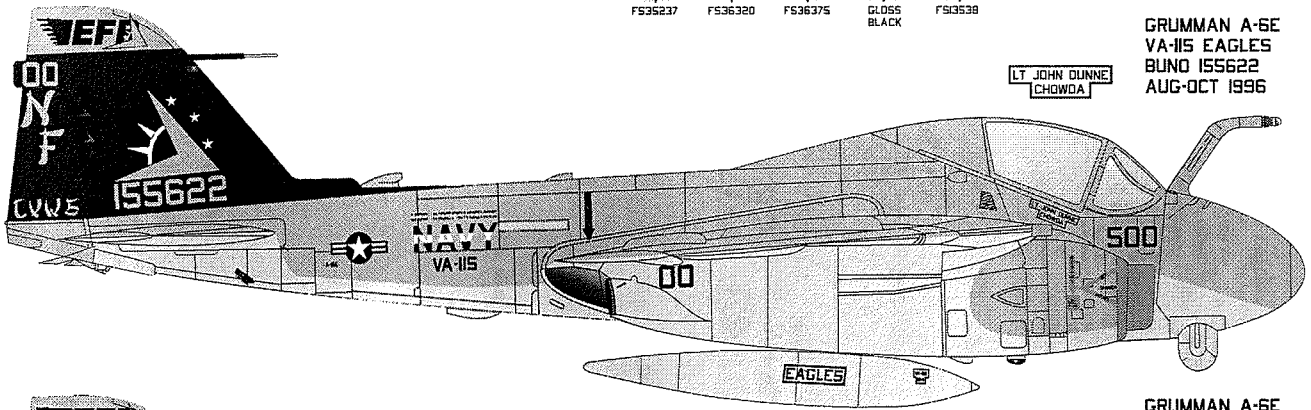

GRUMMAN A-6E
VA-115 EAGLES
BUND 155704
RIMPAC JULY 1996

CAPT DICK MAUDLIN
[DCAG]

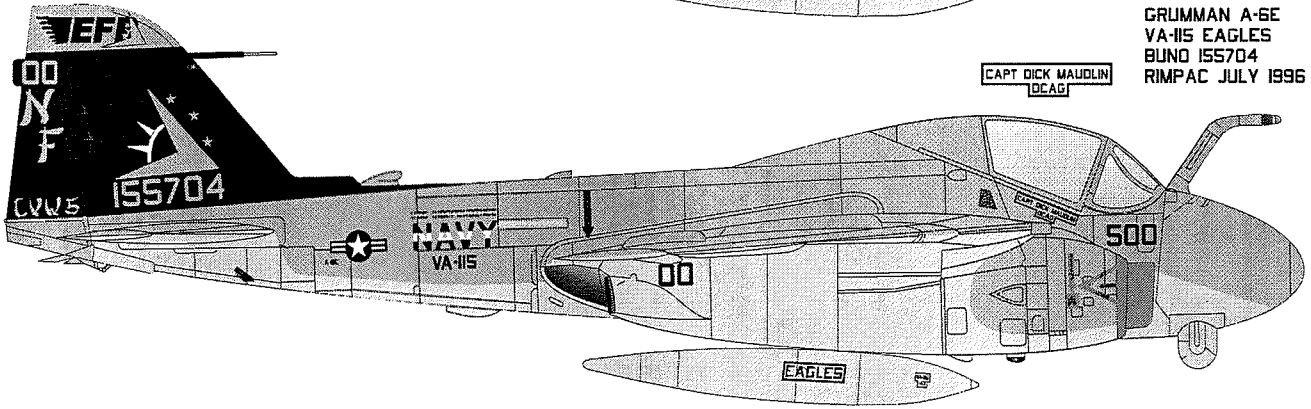

GRUMMAN A-6E
VA-115 EAGLES
BUND 164310
1994

CDR RICK MCHARG
[CO]

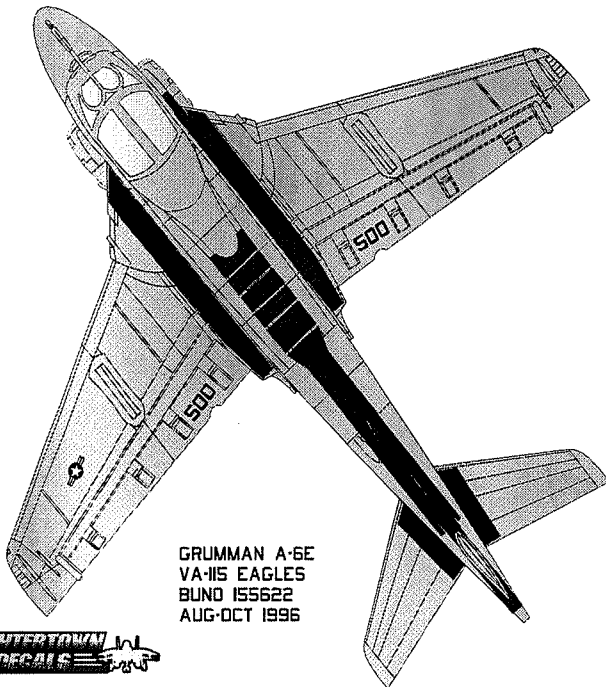
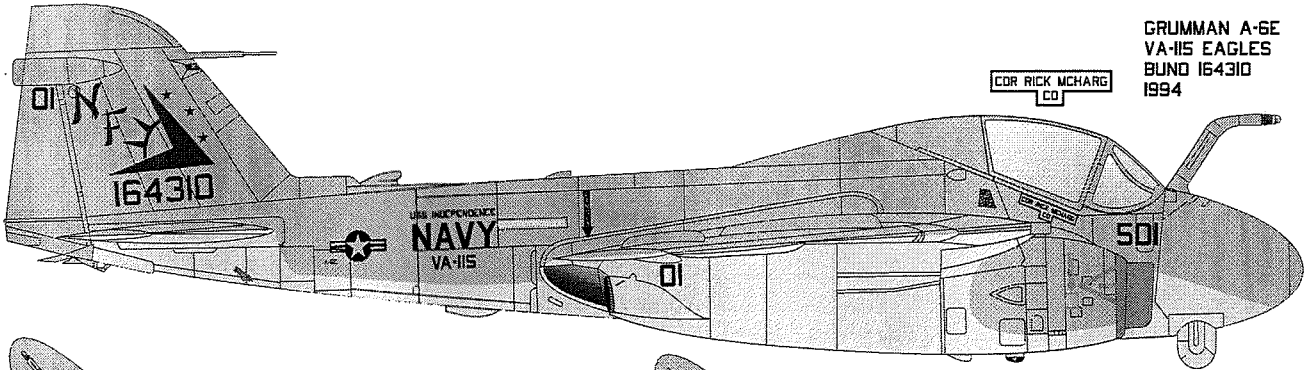

GRUMMAN A-6E
VA-115 EAGLES
BUND 155622
AUG-OCT 1996

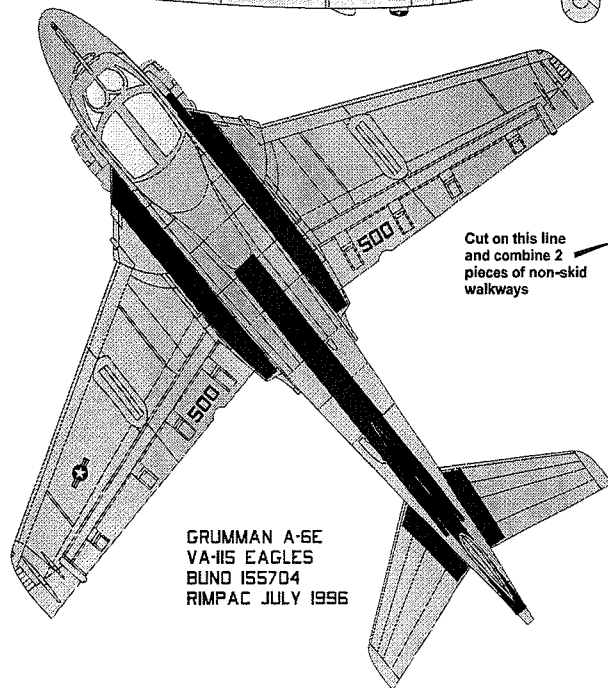

GRUMMAN A-6E
VA-115 EAGLES
BUND 155704
RIMPAC JULY 1996

Cut on this line
and combine 2
pieces of non-skid
walkways



KINETIC
Model Kits

GRUMMAN A-6E INTRUDER SWIP
01-124-48023

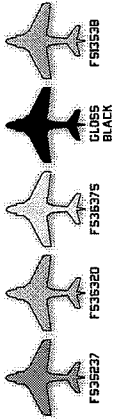

GRUMMAN A-6E
VA-115 EAGLES
BUNO 155622
AUG-OCT 1996

LT ERIC HAMM
BDNE

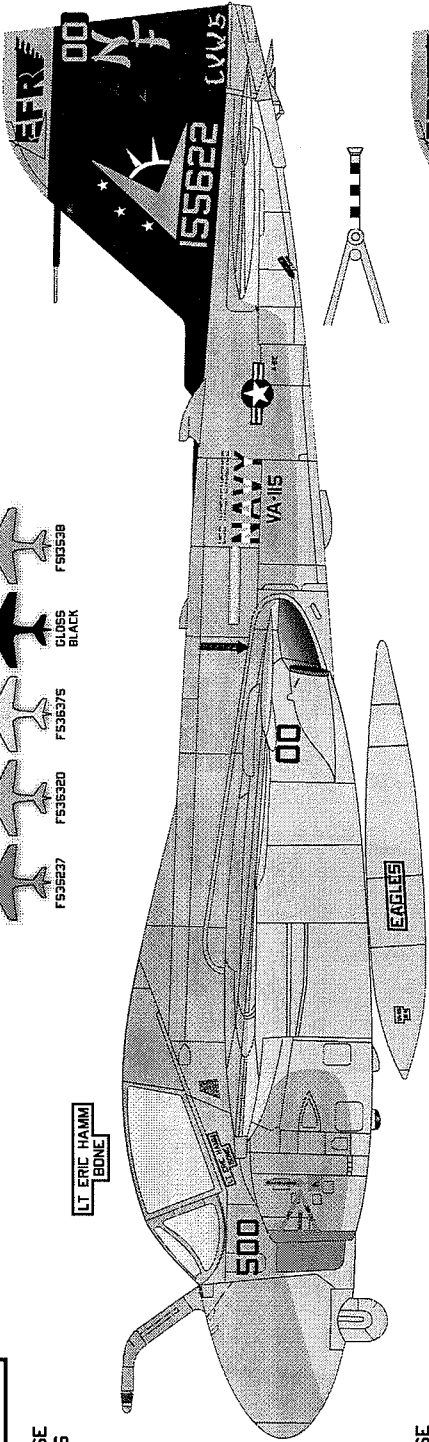

GRUMMAN A-6E
VA-115 EAGLES
BUNO 155704
RIMPAC JULY 1996

CAPT BRIAN CALHOUN
LAG

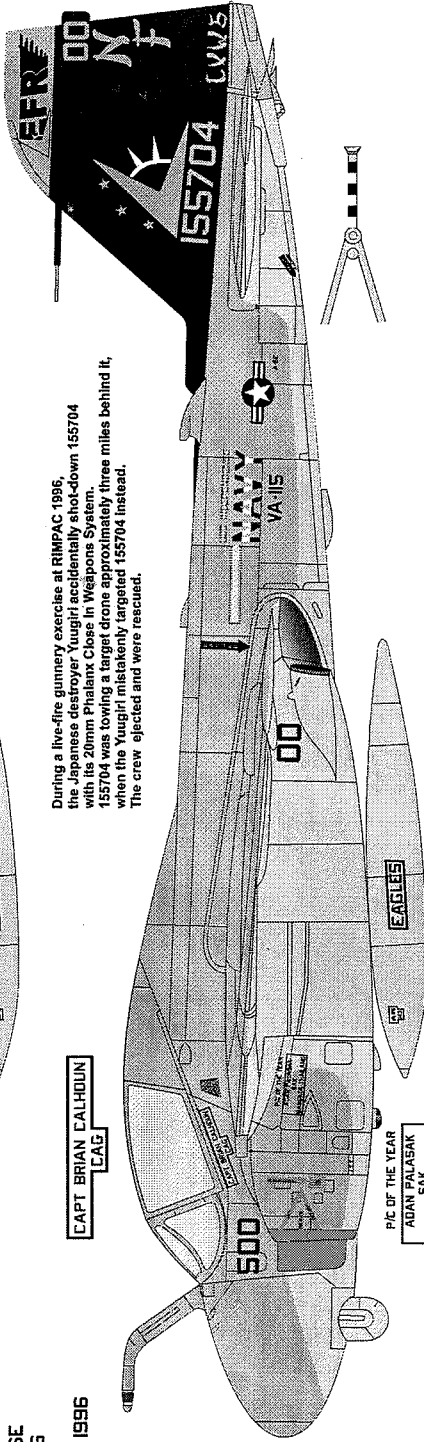

During a live-fire gunnery exercise at RIMPAC 1996, the Japanese destroyer Yuugiri accidentally shot-down 155704 with its 20mm Phalanx Close In Weapons System. 155704 was towing a target drone approximately three miles behind it, when the Yuugiri mistakenly targeted 155704 instead. The crew ejected and were rescued.

P/O OF THE YEAR
ADAN PALASAK
SAK
BANGKOK THAILAND

GRUMMAN A-6E
VA-115 EAGLES
BUNO 164310
1994

CDR ALDO KUNTZ
XO

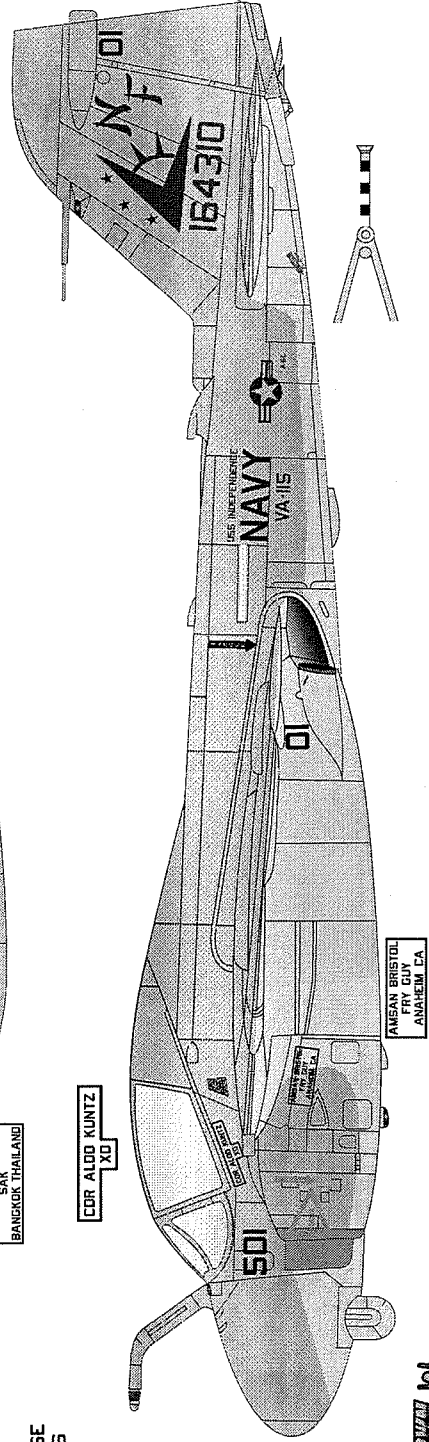

AMEAN BRISTOL
LUTY
ANALEEM EA

