

KIT2169

85216900200

# '31 Ford Model A Sedan Hot Rod 2'n1

The time period from the late 1920's to the early 1930's was an important one for both Henry Ford's little company in Detroit as well as the young automobile industry as a whole. Gone were the spindly suspensions and tall wooden spoke wheels, in their place automobiles that were lower, more durable and easier to drive.

This did not go un-noticed by the hot rodding community. Ford's rugged little Model A had classic good looks with or without fenders. While nearly every engine type ever made has appeared between the frame rails of the '31, a good many rodders kept the spunky 40 horsepower four cylinder and in fact added speed parts of the period to theirs.

Your Revell 1931 Ford Sedan kit includes many of these period speed parts in scale for you to choose whether to add them to yours. These include a revised cylinder head and intake manifold equipped to handle two carbs, chrome valve covers and exhaust headers.

We also include your choice of two different seat treatments, two different sets of wheels-modern mags or go for the steelies with caps & rings on wide white-walls, a look that's extremely popular once again.

Add in the opening hood and doors and you can see why this kit has been one of our most requested over the last few years. We're happy to bring it back for to you to enjoy once again.

You have two building options available to you with this kit. Please take a few moments to look over the building versions prior to beginning construction.

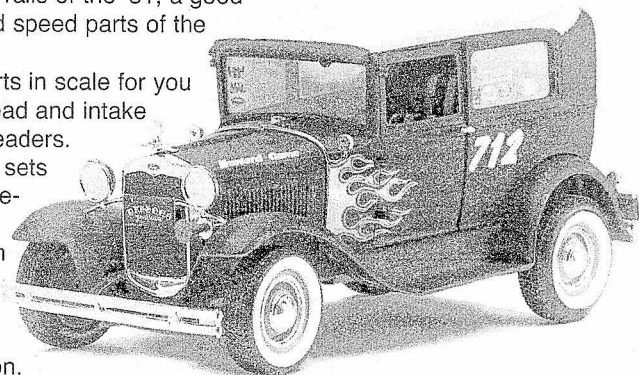

\* REPEAT SEVERAL TIMES  
\* A REPETER PLUSIEURS FOIS



\* OPTIONAL PARTS  
\* PIECES EN OPTION



\* DECAL  
\* DECAL COMANIE



\* ALTERNATIVE ASSEMBLY  
\* ENSEMBLAGE ALTERNATIVE



\* CEMENT TOGETHER  
\* A COLLER



\* REMOVE AND THROW AWAY  
\* A RETIRER ET JETER



\* DO NOT CEMENT  
\* NE PAS COLLER

### READ THIS BEFORE YOU BEGIN

- \* Study the assembly drawings.
- \* Each plastic part is identified by a number.
- \* In the assembly drawings, some parts will be marked by a star (\*) to indicate chrome plated plastic.
- \* For better paint and decal adhesion, wash the plastic parts in a mild detergent solution. Rinse and let air dry.
- \* Check the fit of each piece before cementing in place.
- \* Use only cement for polystyrene plastic.
- \* Scrape plating and paint from areas to be cemented.
- \* Allow paint to dry thoroughly before handling parts.
- \* Any unused parts may be discarded.

### DECAL APPLICATION INSTRUCTIONS

1. Cut desired decal from sheet.
2. Dip decal in water for a few seconds.
3. Place wet decal on paper towel.
4. Wait until decal is movable on paper backing.
5. Place decal in position on model, face up and slide backing away.
6. Press out air bubbles with a soft damp cloth.
7. Milkiness that may appear is for better decal adhesion and will dry clear. Wipe away any excess adhesive.
8. Do not touch decal until fully dry.
9. Allow the decals 48 hours to dry before applying clear coat.

**NOTE:** Decals are compatible with setting solutions or solvents.

### LIRE CE QUI SUIT AVANT DE COMMENCER

- \* Etudier les schémas de montage.
- \* Chaque pièce en plastique est identifiée par un numéro.
- \* Sur les schémas de montage, certaines pièces sont marquées d'une étoile (\*) pour indiquer qu'elles sont en plastique chromé.
- \* Pour une meilleure prise de la peinture et des autocollants, laver les pièces en plastique avec une solution détergente peu concentrée. Les rincer et les laisser sécher à l'air.
- \* Vérifier que chaque pièce s'ajuste bien avant de la coller en place.
- \* N'utiliser que de la colle pour polystyrène.
- \* Gratter les parties à coller pour enlever le chrome et la peinture.
- \* Laisser la peinture bien sécher avant de manipuler les pièces.
- \* Toute pièce inutilisée peut être jetée.

### DIRECTIVES D'APPLICATION DES AUTOCOLLANTS

1. Découper l'autocollant désiré de la feuille.
2. Tremper l'autocollant dans de l'eau pendant quelques secondes.
3. Placer l'autocollant mouillé sur une serviette en papier.
4. Attendez que l'autocollant puisse être déplacé sur son support en papier.
5. Mettre l'autocollant en position sur le modèle face sur le dessus et faire glisser le support pour l'enlever.
6. Appuyer avec un chiffon doux humide pour éliminer les bulles d'air.
7. La substance laiteuse qui peut apparaître est destinée à améliorer l'adhésion de l'autocollant et devient incolore au séchage. Essuyer pour enlever tout excédent d'adhésif.
8. Ne pas toucher l'autocollant tant qu'il n'est pas bien sec.
9. Laisser l'autocollant sécher pendant 48 heures avant d'appliquer une couche transparente.

**REMARQUE:** Les autocollants sont compatibles avec les solutions de fixation ou les solvants.

### This optional paint guide is provided if you choose to detail paint your model.

Ce guide de peinture vous sera fourni si vous choisissez de peindre votre modèle en détail.

Aluminum	Aluminum
Flat Black	Noir mat
Flat White	Blanc mat
Gloss Red	Rouge lustré
Gloss White	Blanc lustré
Gold	Or
Gunmetal	Bronze
Jet Exhaust	Flux d'éjection
Gloss Lime Gold Metal Flake	Or lime à paillettes métallisés lustré
Satin Black	Noir satiné
Satin White	Blanc satiné
Transparent Red	Rouge transparent

If you have any questions or comments, call our hotline at: **(800) 833-3570** or, please write to:

Revell-Monogram Consumer Service Department, 8601 Waukegan Road, Morton Grove, Illinois 60053  
Be sure to include the plan number (85216900200), part number, description, your return address and phone number.

Visit our website: [www.revell-monogram.com](http://www.revell-monogram.com)

# ENGINE ASSEMBLY

**NOTE: COLORS ARE SPECIFIED IN TWO VERSIONS. VERSION A IS CALLED OUT IN ITALICIZED TYPE. VERSION B IS CALLED OUT IN BOLD ITALICIZED TYPE. WHEN THERE IS ONLY ONE COLOR IT DENOTES A COMMON COLOR FOR BOTH VERSIONS.**

**A**

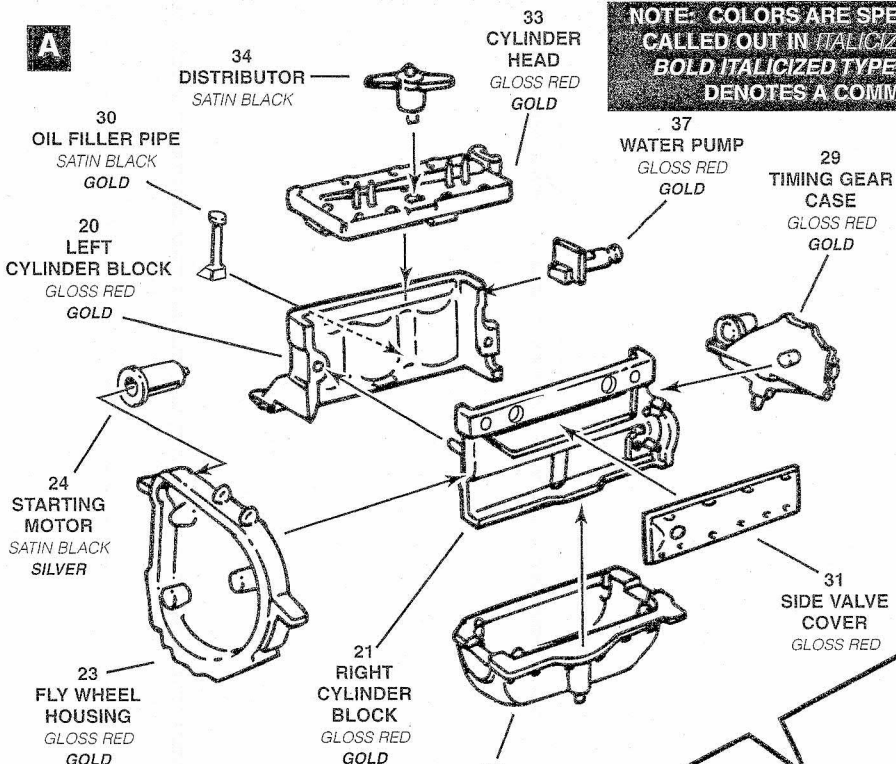

**B**

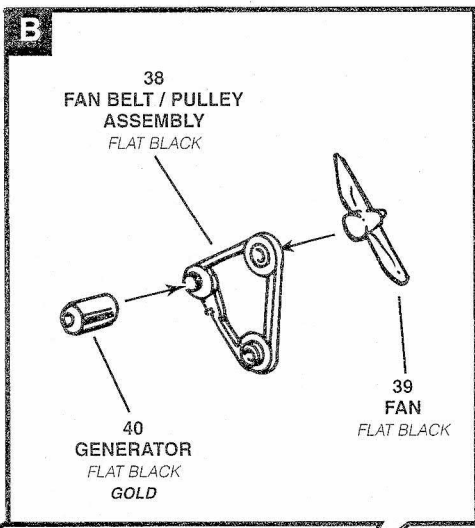

**D**

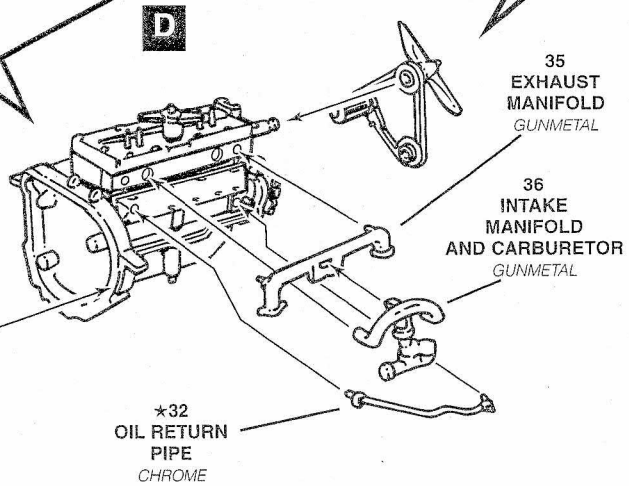

**C**

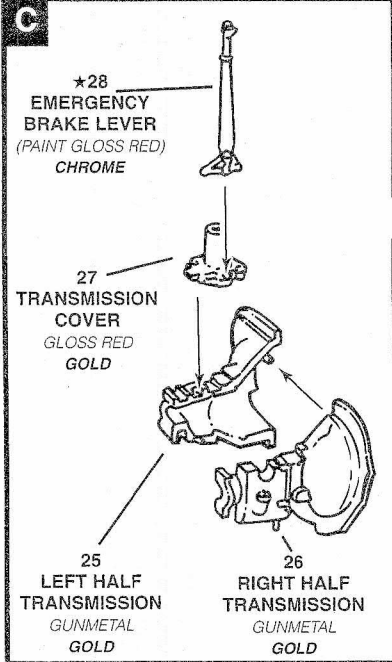

**ENGINE FOR VERSION B ONLY**

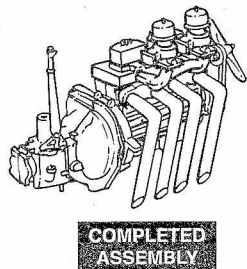
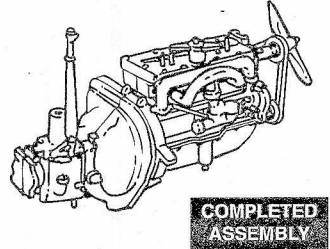
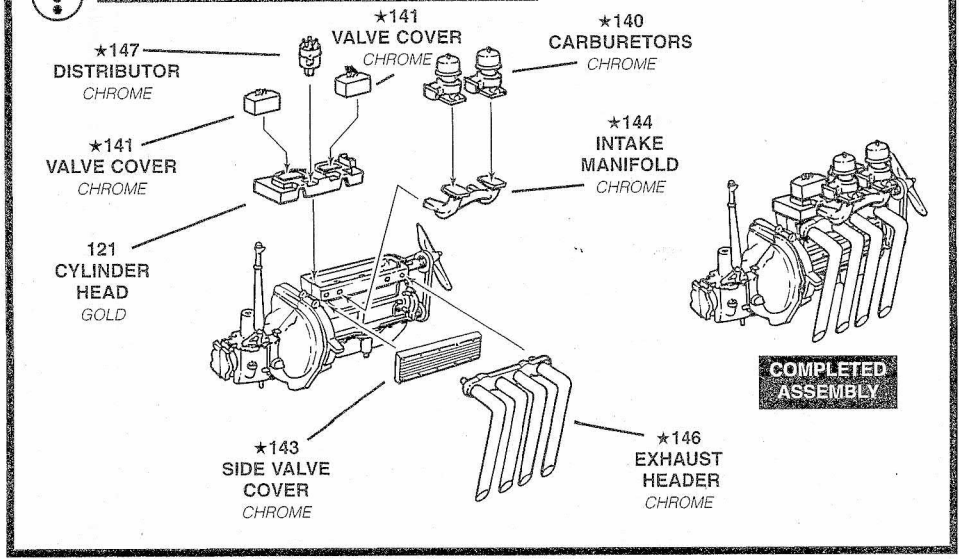

# 2

# FRAME ASSEMBLY

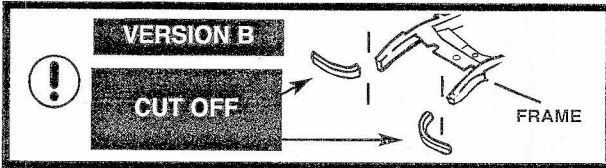

**NOTE: DO NOT GLUE HOSES TO RADIATOR CORE (47) IN ORDER TO ATTACH HOOD IN STEP 9**

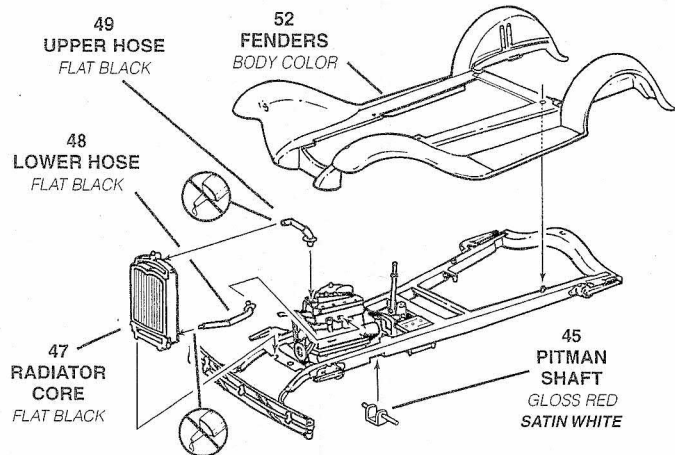
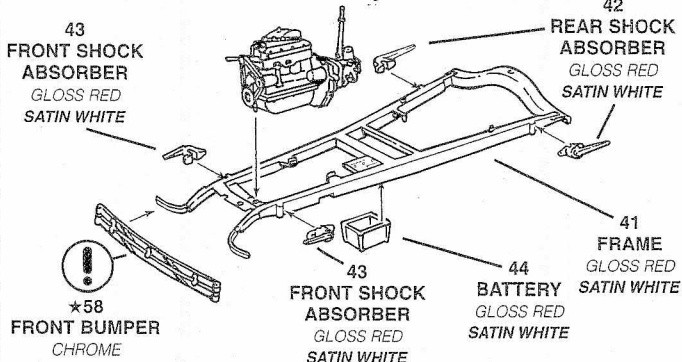

# 3

# FRONT SUSPENSION ASSEMBLY

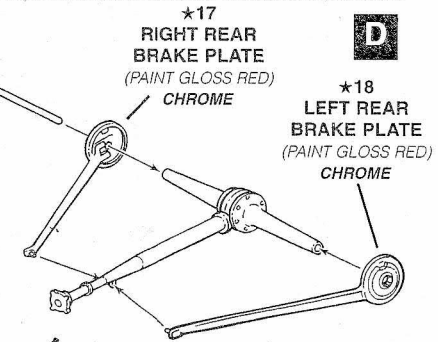
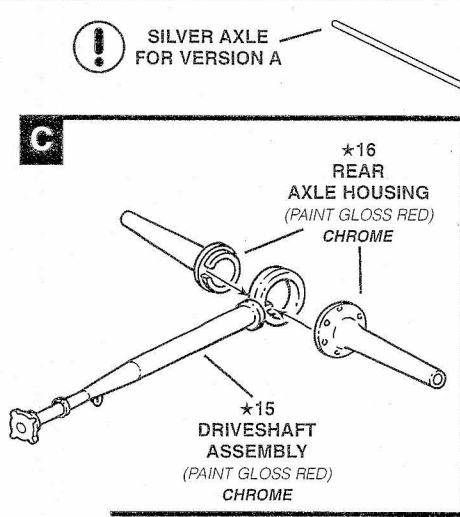
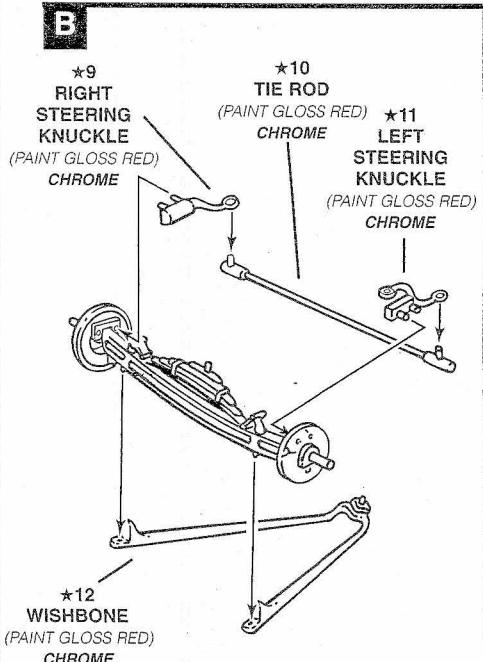
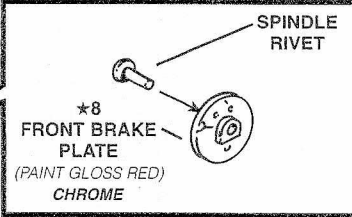
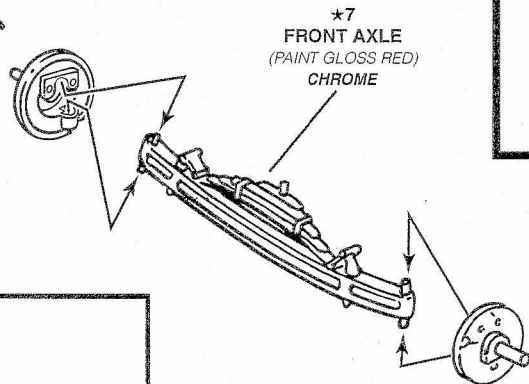
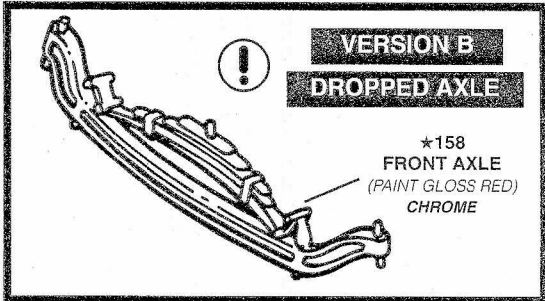
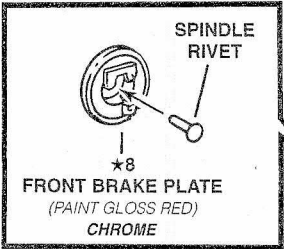

**BLACK AXLE FOR VERSION B**



# 3

# FRONT SUSPENSION ASSEMBLY CONTINUED

**E**

★19  
REAR  
SPRING  
(PAINT GUNMETAL)  
CHROME

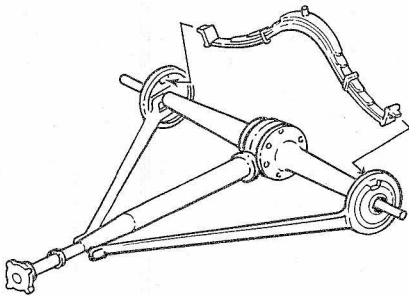
**F**

★14  
PITMAN  
ARM  
(PAINT GLOSS RED)  
CHROME

★13  
DRAG LINK  
(PAINT GLOSS RED)  
CHROME

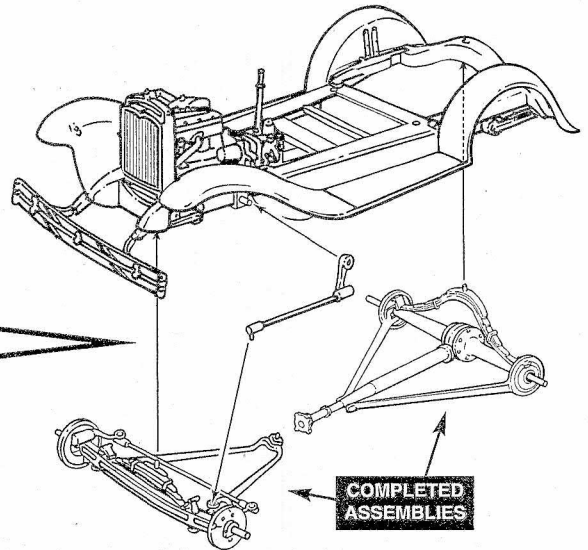
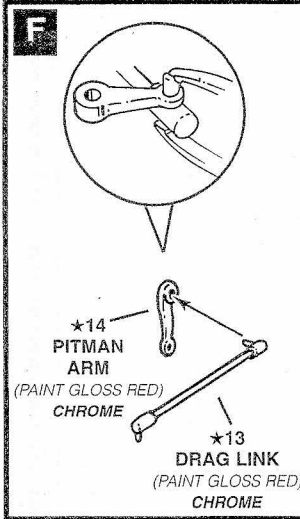
**COMPLETED ASSEMBLIES**

# 4

# WHEEL ASSEMBLY

**VERSION A****FRONT**

(2X)  
113  
INNER RING  
GLOSS RED

111  
WHEEL  
GLOSS RED

SMALL  
TIRE

103  
WHITEWALL

★115  
BEAUTY  
RING  
CHROME

★114  
HUB CAP  
CHROME

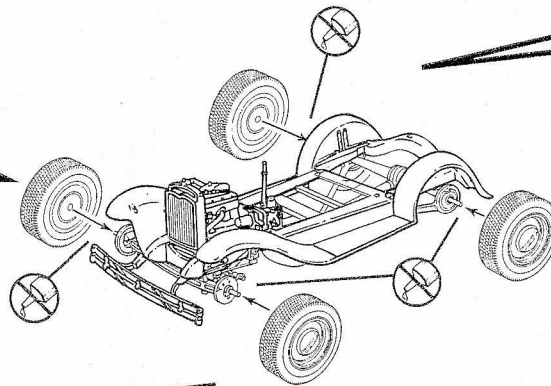
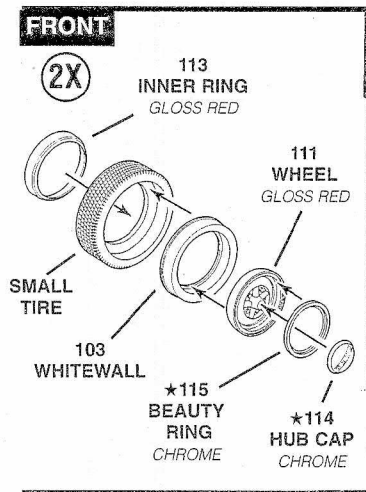
**REAR**

(2X)

113  
INNER RING  
GLOSS RED

LARGER  
TIRE

112  
WHEEL  
GLOSS RED

102  
WHITEWALL

★115  
BEAUTY  
RING  
CHROME

★114  
HUB CAP  
CHROME

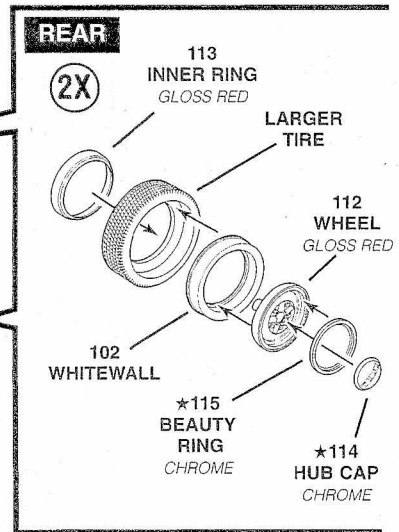
**VERSION B****FRONT**

(2X)



★151  
INNER RING  
CHROME

★148  
MAG WHEEL  
CHROME

PIRELLI  
TIRE

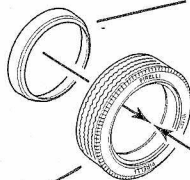
**REAR**

(2X)

★150  
INNER RING  
CHROME

LARGER  
TIRE

102  
WHITEWALL

★149  
MAG WHEEL  
CHROME

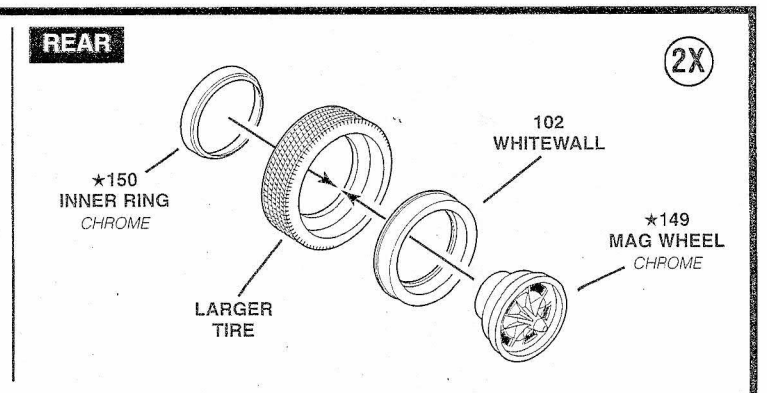



# 5 EXHAUST AND FLOOR BOARD ASSEMBLY

**NOTE: EXHAUST FOR VERSION A ONLY**

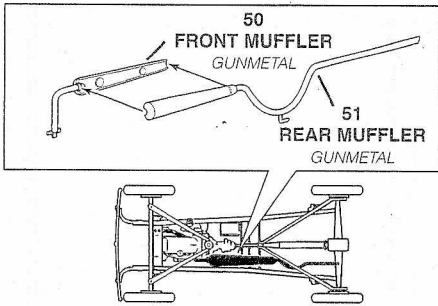

**NOTE: CUT OUT HOLES FOR CONVENTIONAL SEATS ONLY**

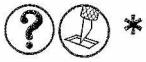

126 FLOOR BOARD  
FLAT BLACK  
SATIN WHITE  
(PAINT UNDERSIDE  
BODY COLOR)

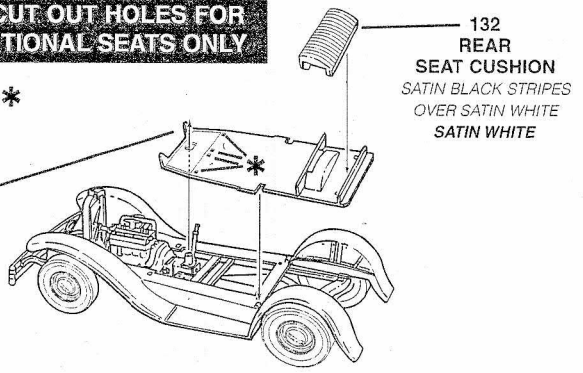

# 6 INTERIOR ASSEMBLY

**NOTE: IF YOU WANT THE SPORT SEAT TO SWIVEL GLUE SEAT RETAINER (136) TO SPORT SEAT BRACKET (134) ONLY**

**NOTE: THE TEMPLATE SHOWN ON THE RIGHT IS FOR THE FRONT, SIDES AND REAR OF THE 31 FORD. COPY TEMPLATE AND CUT OUT OF AN ACETATE SHEET PROVIDED WITH KIT TRIM TO FIT OPENING**

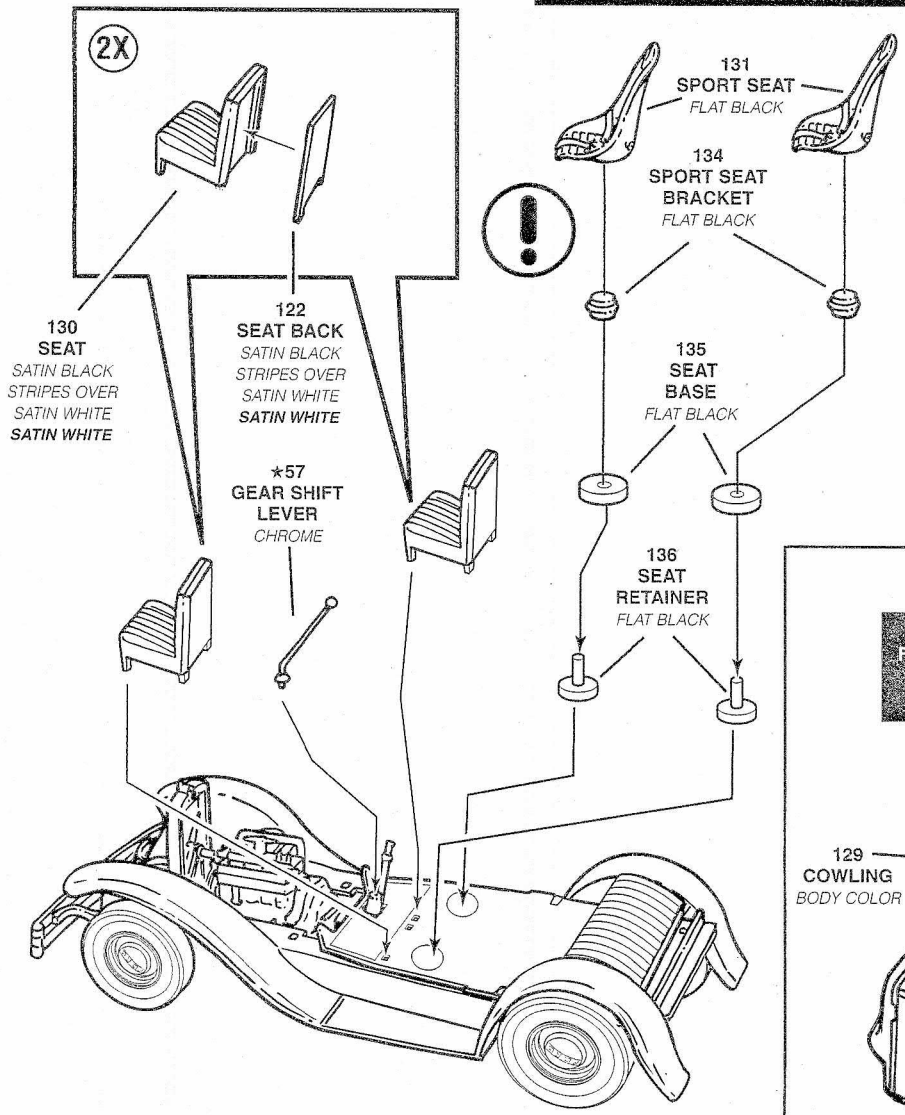

**NOTE: CUT WINDSHIELD FROM PLASTIC SHEET, USE WHITE GLUE TO ATTACH WINDSHIELD**

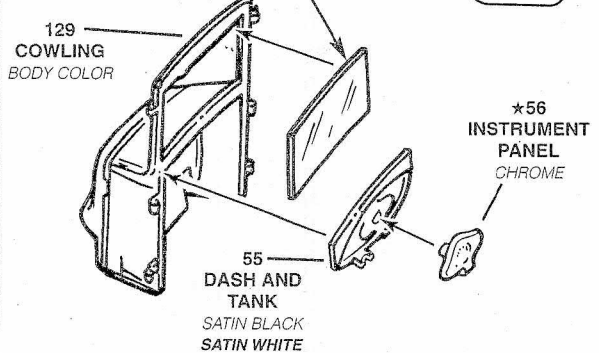

**NO BUMPER BRACKET ON VERSION B**

# CAB ASSEMBLY

COMPLETED COWLING ASSEMBLY

76 STEERING WHEEL  
FLAT BLACK  
SATIN WHITE

BODY ASSEMBLY

NOTE: ASSEMBLE COMPLETED COWLING AND BODY TOGETHER BEFORE ATTACHING IT TO CHASSIS

75 STEERING COLUMN  
FLAT BLACK  
SATIN WHITE

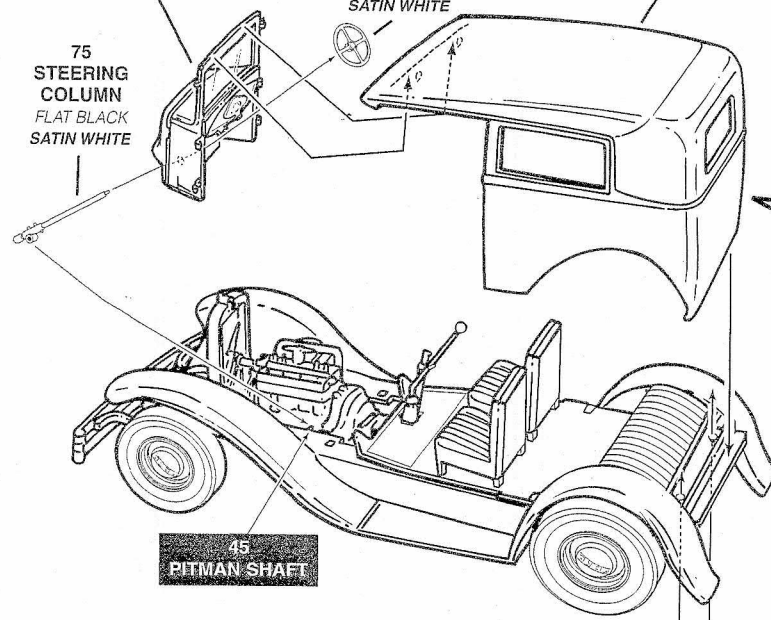

45 PITMAN SHAFT

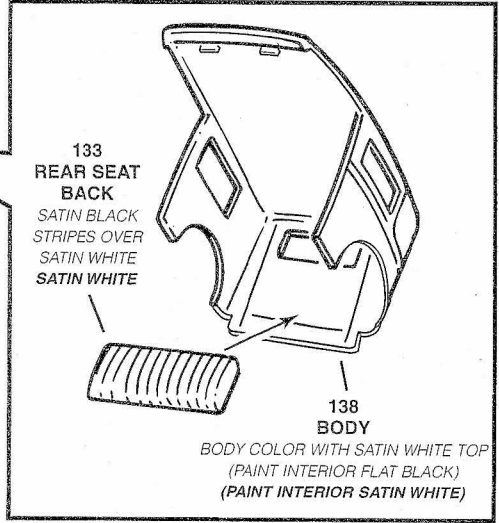

133 REAR SEAT BACK  
SATIN BLACK  
STRIPES OVER  
SATIN WHITE  
SATIN WHITE

138 BODY

BODY COLOR WITH SATIN WHITE TOP  
(PAINT INTERIOR FLAT BLACK)  
(PAINT INTERIOR SATIN WHITE)

NOTE: CUT BACK AND SIDE WINDOWS FROM PLASTIC SHEET. USE WHITE GLUE TO ATTACH BACK AND SIDE WINDOWS

NOTE: STEERING COLUMN (75) AND STEERING WHEEL (76) CAN BE INSERTED INTO THE CAB AFTER THE BODY AND THE COMPLETED COWLING HAVE BEEN INSTALLED

USE FOR VERSION A ONLY

137 REAR BUMPER BRACKET  
GLOSS RED

# FRONT END ASSEMBLY

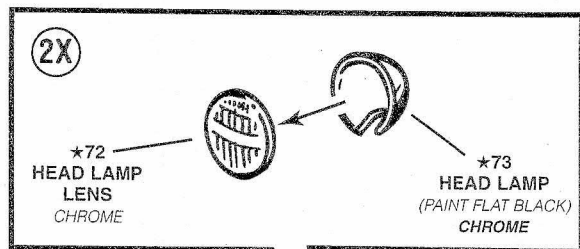

2X

\*72 HEAD LAMP LENS  
CHROME

\*73 HEAD LAMP  
(PAINT FLAT BLACK)  
CHROME

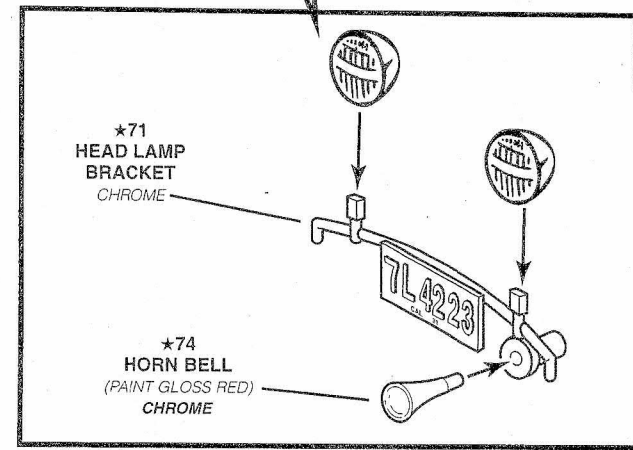

\*71 HEAD LAMP BRACKET  
CHROME

\*74 HORN BELL  
(PAINT GLOSS RED)  
CHROME

\*70 RADIATOR SHELL  
CHROME

\*68 TRIM AND PARKING LAMPS  
CHROME

FIRST

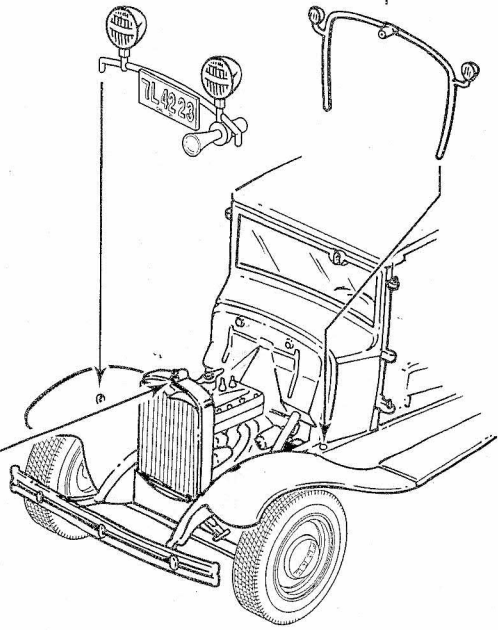

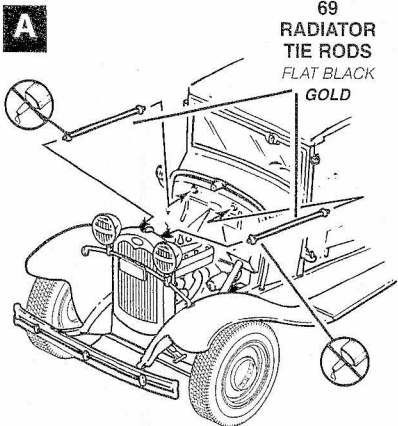

**NOTE:** RADIATOR TIE RODS (69) ARE NOT GLUED TO RADIATOR IN ORDER TO AID IN THE INSTALLATION OF THE HOOD

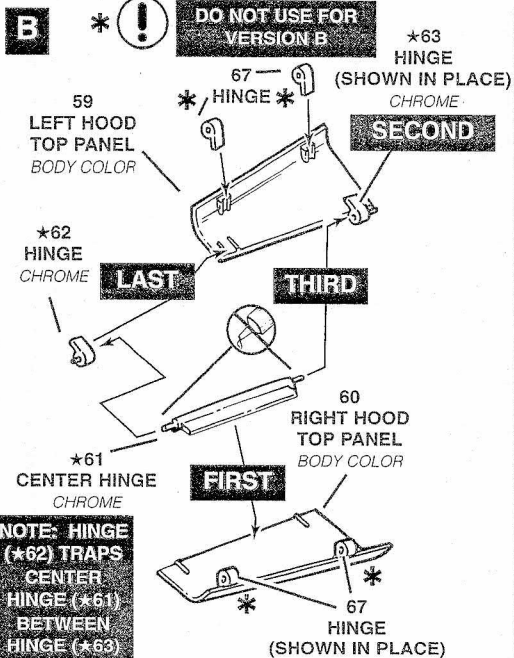

**NOTE:** HINGE (\*62) TRAPS CENTER HINGE (\*61) BETWEEN HINGE (\*63)

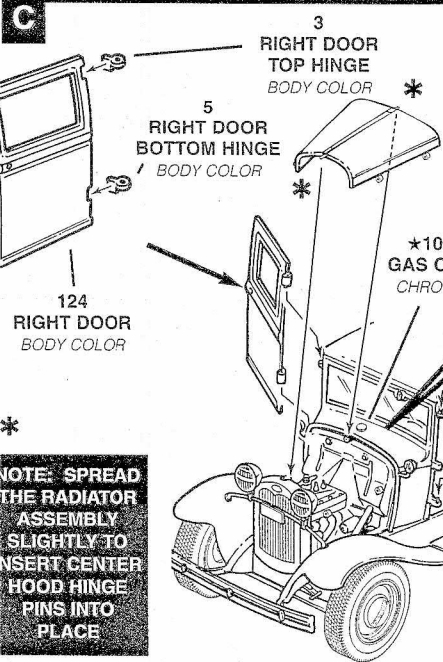
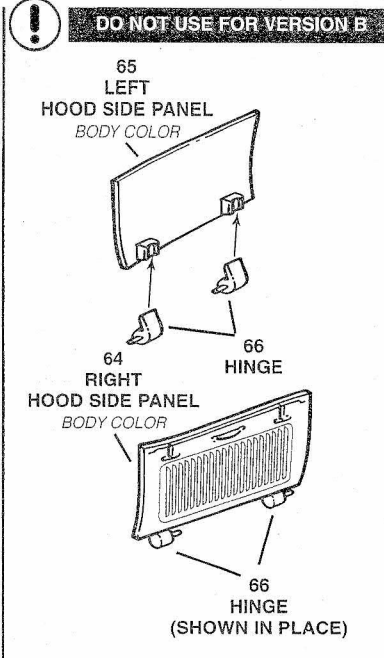

**NOTE:** SPREAD THE RADIATOR ASSEMBLY SLIGHTLY TO INSERT CENTER HOOD HINGE PINS INTO PLACE

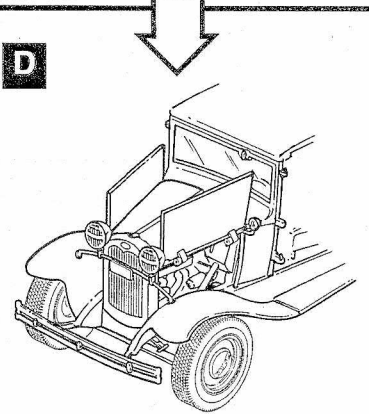

**NOTE:** INSERT LEFT AND RIGHT SIDE HOOD SIDE PANELS FOR VERSION A ONLY

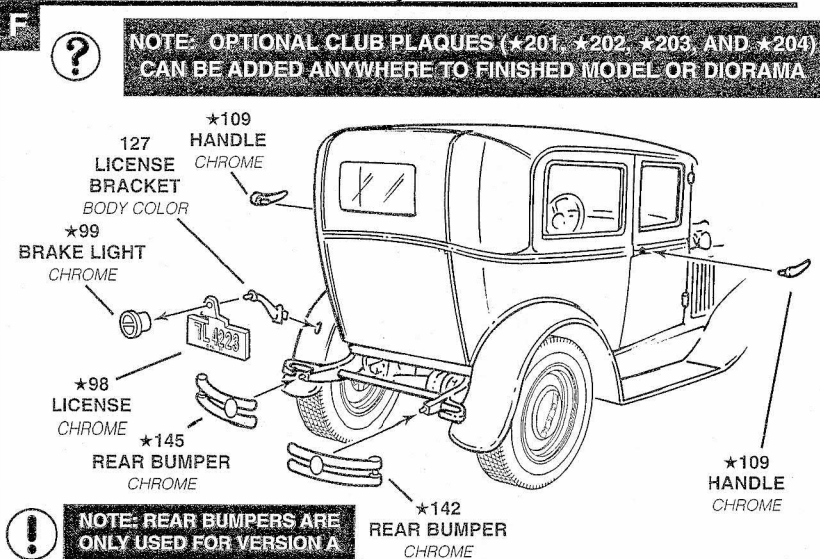
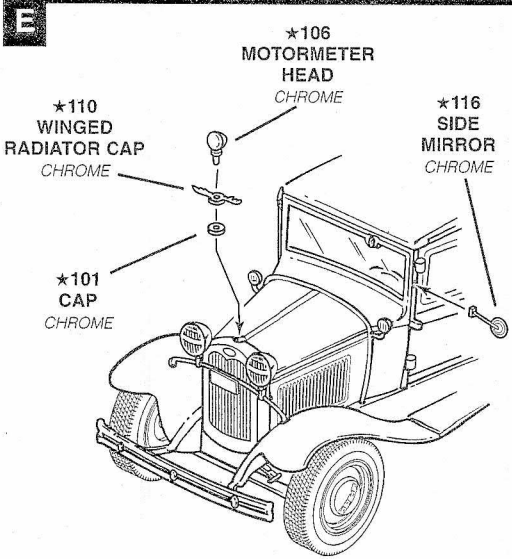

**NOTE:** REAR BUMPERS ARE ONLY USED FOR VERSION A



## Version A



**FLAT BLACK**

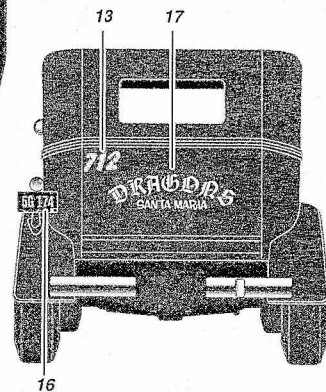
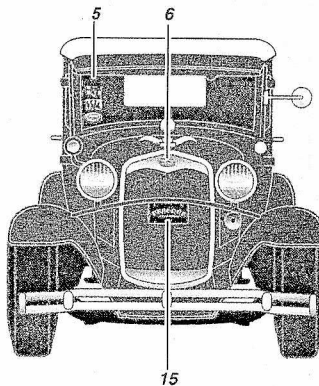
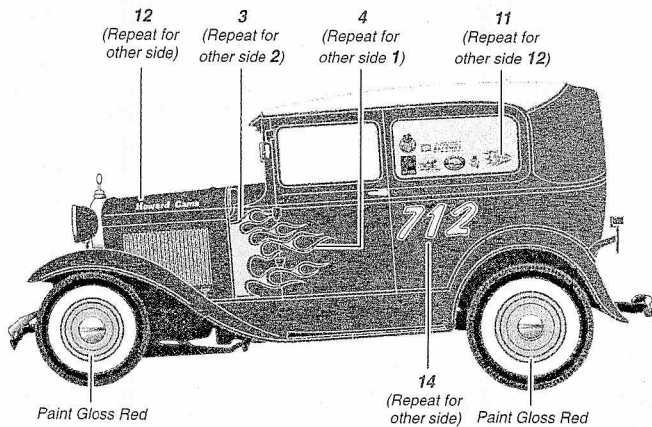

## Version B

**GLOSS LIME GOLD METAL FLAKE**

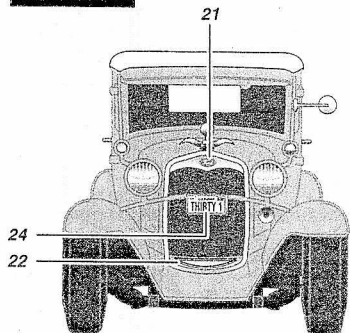

Note: APPLY THIS DECAL LAST  
 pinstriping will slightly overlap

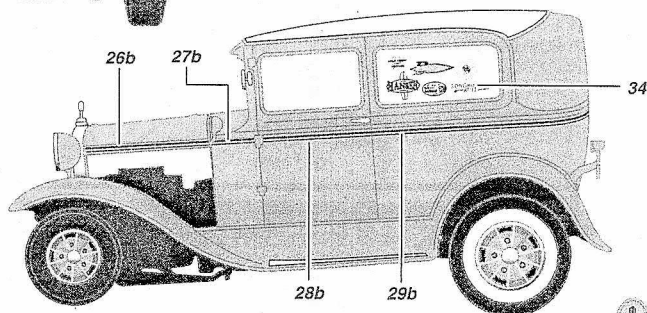
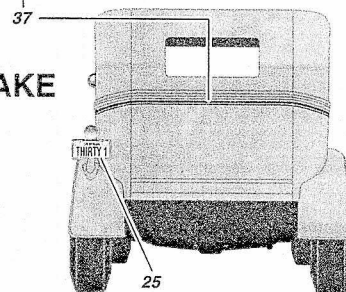

Note: pinstriping on fenders will slightly overlap

