

A-10 Warthog Stencils

As with most military aircraft, and especially with modern US warplanes, the style and placement of maintenance and warning stencils can easily vary from manufacturer's block to block, group to group, squadron to squadron and aircraft to aircraft! We have attempted to provide a selection of the most common varieties of stencils with a few documented oddities added. Note that there are many variations of certain markings. Please check your reference photos for the most appropriate style of stencils for the model you are building.

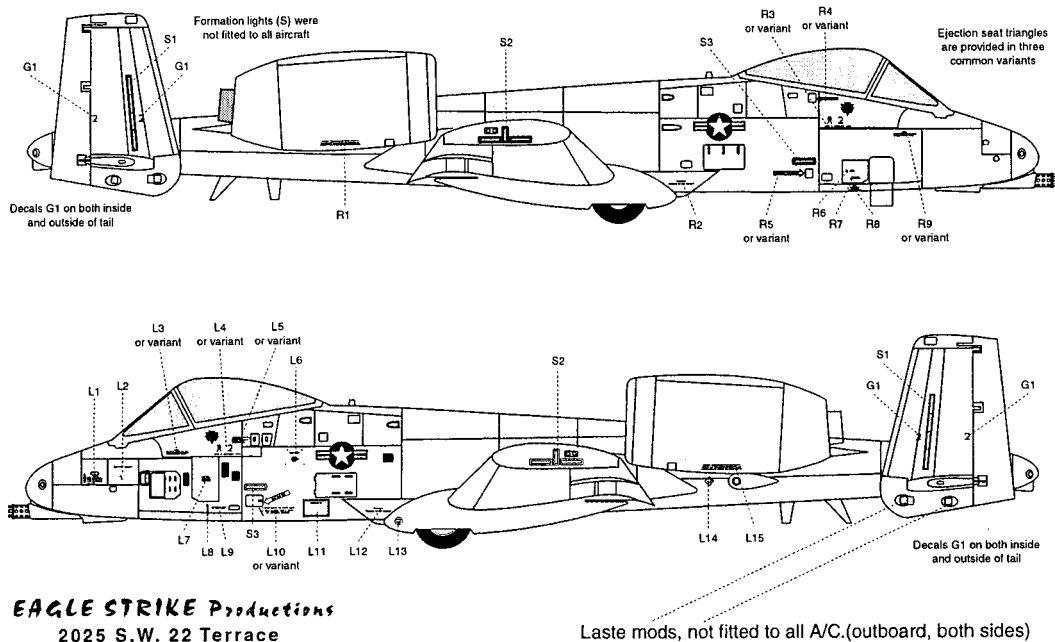

Decaling: Apply decals only to a glossy surface.

1. With a sharp scissors or knife, carefully cut item to be used, being careful of not cutting off the clear film around it or that belonging to an adjacent item.

2. Submerge in clean tap water for over 10 seconds and lay over an absorbent paper towel. Decal will slide freely in about 20 seconds. Do not leave decal on water bowl over ten seconds, or adhesive quality will suffer.

3. With a clean brush, apply a setting solution to the area where the decal will finally lay. (Micro, Super or Aero Set will do). With a clean pointed brush slide the decal on to the final area. Allow the setting solution to dry for about 3-5 minutes.

4. With another clean brush, apply a solvent solution over the decal (Micro, Super or Aero Sol will do). Do this if possible in one stroke since your decal will soften up and wrinkle immediately. This is an important step in the process, whatever you do, **DO NOT TOUCH THE DECAL** after this process until it is totally dry, preferably overnight.

5. When thoroughly dry, rinse your model with tap water and mild soap to wash off excess glue.

6. Finish your model with the desired final coat (gloss, flat, or semi-gloss).

EAGLE STRIKE Productions

2025 S.W. 22 Terrace
Miami, Fl. 33145 U.S.A
fax (305) 285-7219

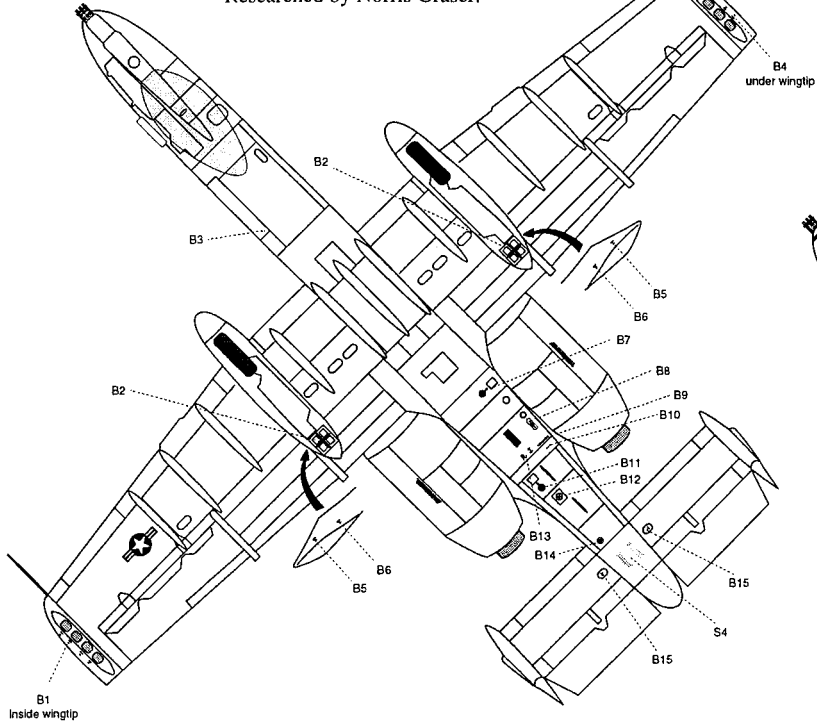

Style 'A'

WARNING
ENGINE RUN UP, TAXI OR FLIGHT IS PROHIBITED WITH BATTERY CIRCUIT BREAKERS PULLED. IF FAULT HAS CAUSED TRIP, REPAIR CAUSE AND IMMEDIATELY RESET

Style 'B'

WARNING
ENGINE RUN UP TAXI OR FLIGHT IS PROHIBITED WITH CIRCUIT BREAKERS PULLED IF FAULT HAS CAUSED TRIP REPAIR CAUSE AND IMMEDIATELY RESET

Style 'C'

WARNING
ENGINE RUN UP TAXI OR FLIGHT IS PROHIBITED WITH CIRCUIT BREAKERS PULLED IF FAULT HAS CAUSED TRIP REPAIR CAUSE AND IMMEDIATELY RESET

Refuelling target shown in black for clarity

Aircraft stenciled in Style 'C' generally use the 'black spot only' variant of marking T3. Early aircraft used red spots, later changing to black.

