



SS506

# Vampire FB.5 S.A.

1/72 scale detail set for MPM kit • sada detailů pro model MPM 1/72



SS506



ORIGINAL KIT PARTS  
PUVODNÍ DÍLY, STAVENICE

PHOTO-ETCHED PARTS  
LEPÁNE DÍLY

PARTS TO BE REMOVED  
DÍLY K ODSTRANĚNÍ

FILL  
TMĚLIT

SMETRICAL ASSEMBLY  
SMETRICKÁ MONTÁŽ

REMOVE  
ODSTRANIT

BEND  
OHNOUT

REPLACE  
NAHRADIT

GRIND  
OBRUSIT

OPTION  
VOLBA

1  
COLORED ETCHED PARTS  
LEPÁNE BAREVNÉ DÍLY

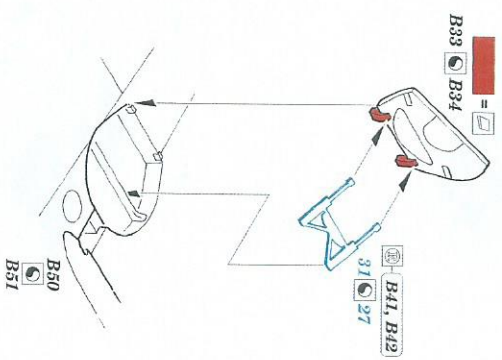
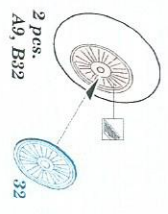
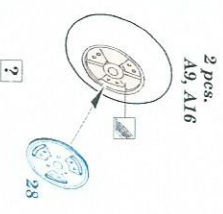
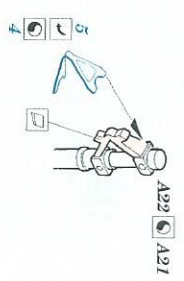
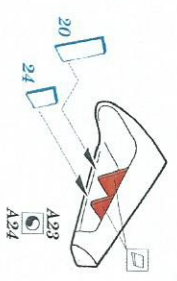
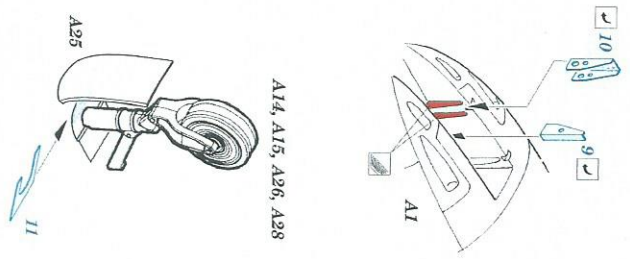
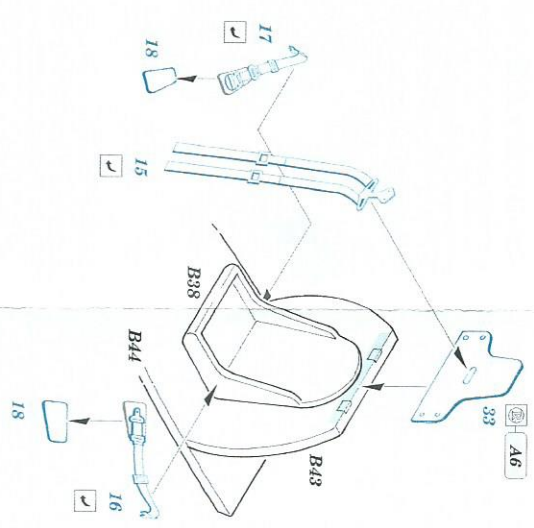
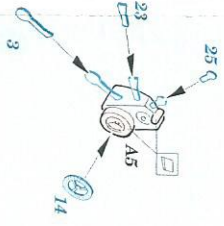
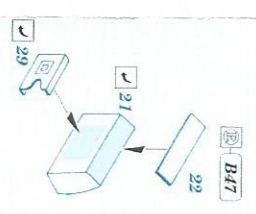
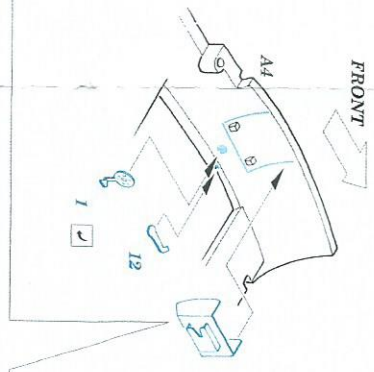
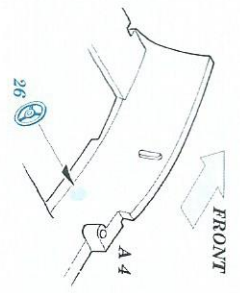
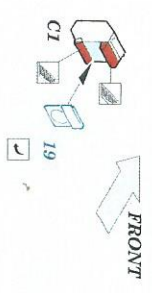
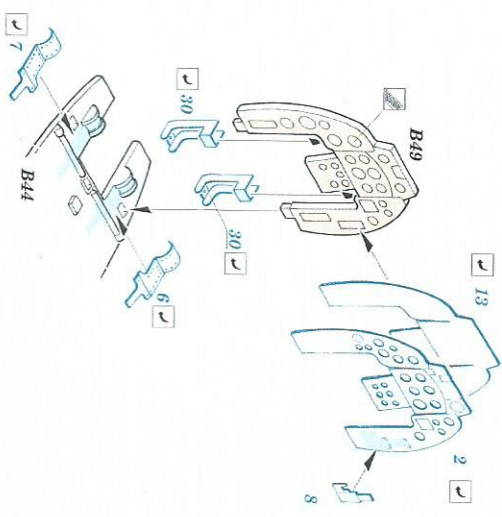

# PARTS WITH GLUE • DÍLY OPATŘENÉ LEPIDLEM

SS506

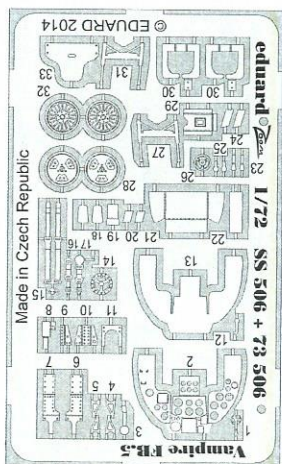

1. Separate the etched components from their frames on the protective paper. Removal from the paper is done only after separation of the parts from the frames.

1. Samolepicí díly oddělte od rámečku na podkladovém papíře. Po oddělení je sejměte z krycího papíru.

3. Do not touch the adhesive areas of the etched components.

3. Nesahajte na částí dílů, na kterých je nanášeno lepidlo.

4. Hold the parts by the edges, or at areas free of adhesive.

4. Samolepicí díly berzte za hrany nebo za části, na kterých není nanášeno lepidlo.



5. Lightly place the component in the desired location and position. Adjust as required. The component will be permanently affixed when pressed onto its intended location, its location can be adjusted.

5. Díl lehce položte do pozice, ve které má být nalepen. Upravte přesnou pozici a přimáčkněte. Díl dokonale přilne až po přimáčknutí, před přimáčknutím lze dílem opatrně manipulovat.

2. Do not inadvertently place etched components on an unwanted surface. Attempts to remove will result in damage to your part.

2. Nepokládejte samolepicí díly na volné plochy. Pokud je omyllem přilepíte, při pokusu o odlepení dojde k poškození dílu.

