



CF-5A Freedom Fighter

The Canadair CF-5 (officially designated the CF-116 Freedom Fighter) is the Canadair licensed-built version of the American Northrop F-5 Freedom Fighter aircraft primarily for the Canadian Forces. The CF-5 was upgraded periodically throughout its service career in Canada. The Canadian Forces retired the type in 1995, although CF-5s continue to be used by other countries.

The CF-5 was ordered by the Royal Canadian Air Force, which became part of the Canadian Forces on 1 February 1968. The new unified force took delivery of the first CF-5s at the end of 1968. Production by Canadair for the Canadian Forces was 89 single-seat aircraft, 46 dual-seat aircraft and 75 single-seat with 30 dual-seat aircraft for the Royal Netherlands Air Force, a total production of 240. Some surplus Canadian aircraft were sold to Venezuela.

A total of 2,350 F-5 Freedom Fighters were produced, between 1962 and 1975; 240 of them by Canadair in Montreal (135 for the CAF and 105 for the Royal Netherlands Air Force).

CAUTION

- *Read carefully and fully understand the instructions before commencing assembly.
- *Keep out of reach of children. Children must not be allowed to put any parts in their mouths, or pull plastic bag over their heads.
- *When using adhesives and paints, please make sure not to use them in closed room or near the fire.
- *When assembling this kit, tools including knives are used. Extra care should be taken to avoid injury.

WARNING: CONTAIN SMALL PARTS NOT FOR CHILDREN UNDER 14 YEARS OF AGE



TOOLS RECOMMENDED

Cement

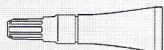

Side Cutter



Modeling Knife



Tweezers



A

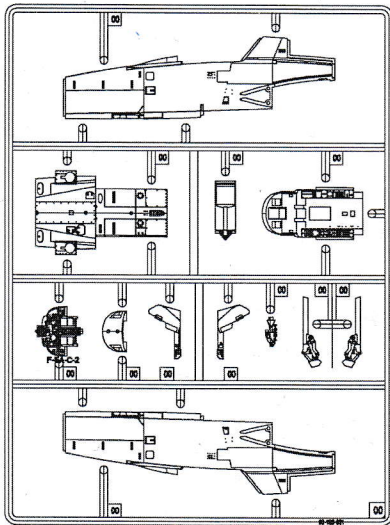

B

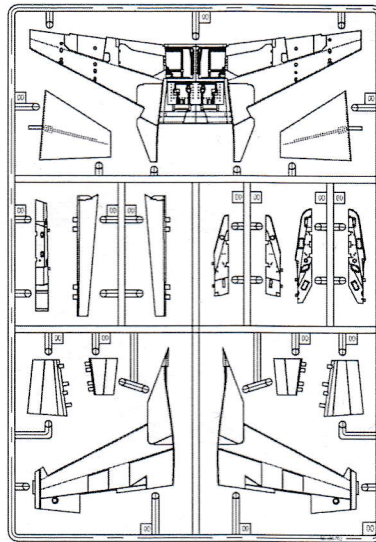

C X 2

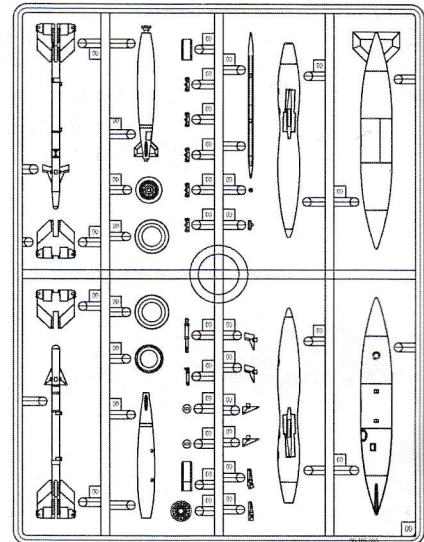

D

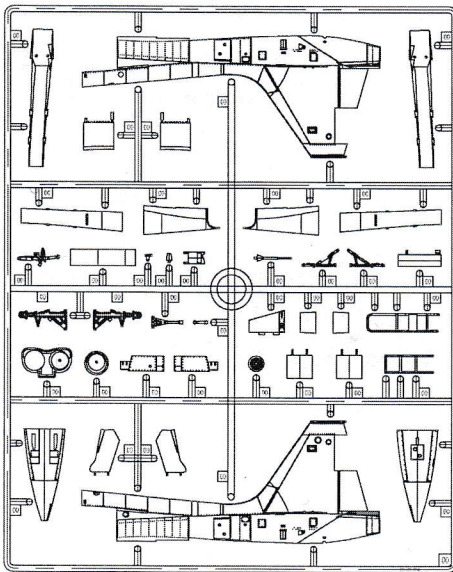

E

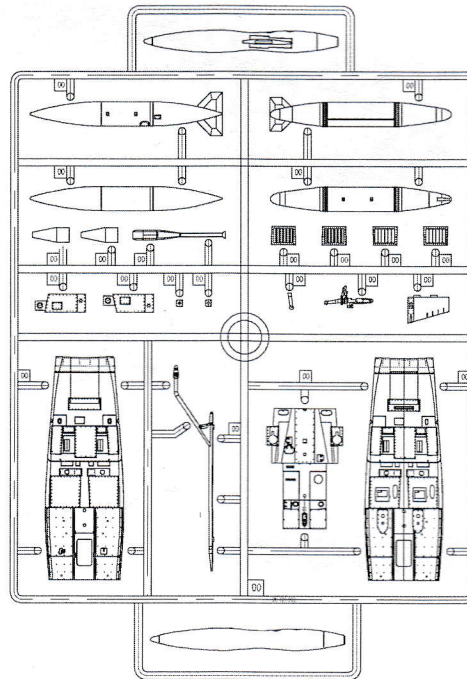

F

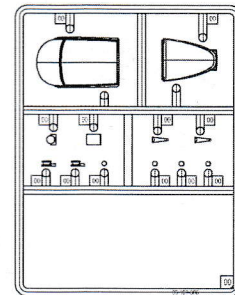

PE

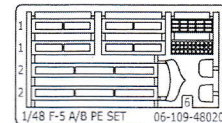

AFTERMARKET SERVICES CARD

When requesting replacement parts, please take or send this form to your local dealer so that the parts required can be correctly identified. Please note that specifications and availability are subject to change without notice. Or visit <http://www.kineticmodel.com> for latest information. For more information, please contact services@kineticmodel.com

Part Code	K48109	QTY	Item
00-109-001	1/48 F-5A FRONT FUESLAGE	1	A
00-109-002	1/48 F-5A/B MAIN WING	1	B
00-109-003	1/48 F-5A/B LANDING GEAR / TANK	2	C
00-109-004	F-5A/B AFTER FUSLEAGE AND PARTS	1	D
00-109-005	F-5A/B BOTTOM FUESLAGE AND CENTER TANK	1	E
00-109-006	F-5A CLEAR PART	1	F
01-109-48109	CF-5A FREEDOM FIGHTER	1	DECAL
03-109-48109	CF-5A FREEDOM FIGHTER	1	MANUAL
06-109-48020	F-5A/B PE Set	1	PE



COLOR	AMMO MIG	VALLEJO MODEL COLOR	GSI CREOS MR. COLOR	TAMIYA ENAMEL/ACRYLIC	HUMBROL ENAMEL
SATIN BLACK	A.MIG-032	70.861	2	X-1	85
RUBBER & TIRES	A.MIG-033	70.306	137	XF-85	67
RED	A.MIG-049	71.003	3	XF-7	60/153
FS 36251 GRAY	A.MIG-059	71.050	H22	-	-
FS 36463 STONE GREY	A.MIG-075	70.989	-	XF-80	-
FS 34064 OLIVE DRAB	A.MIG-112	71.014	302	-	-
SILVER	A.MIG-195	71.063	8	X-11	11
FS36320 GRAY	A.MIG-208	71.120	307	-	128
FS 35237 BLUE GREY	A.MIG-210	71.049	337	-	145
FS 36099 NIGHT BLUE GRAY	A.MIG-250	71.054	36	-	-
FS 36307 HELL GRAU	A.MIG-266	-	324	-	-

For Color Profile, please go to www.kineticmodel.com for download
(type the kit# and go for manual/painting guide)

1

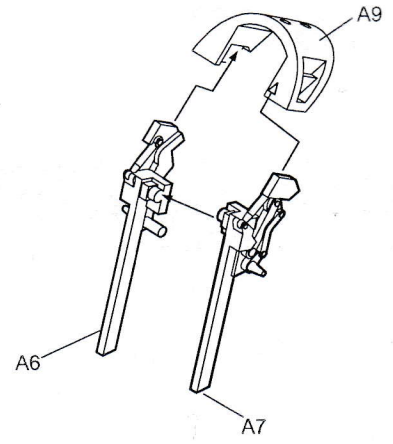
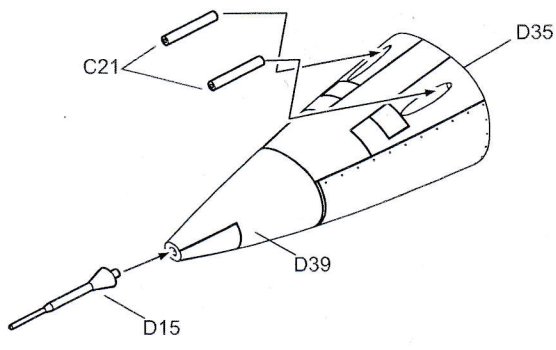
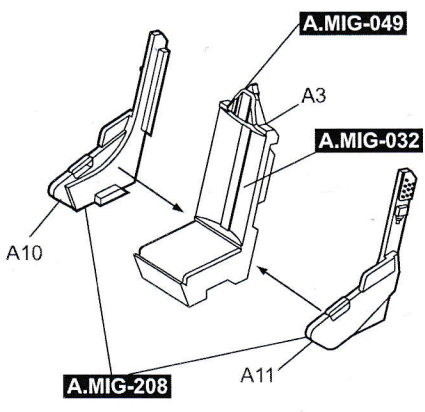

Canopy open option

2

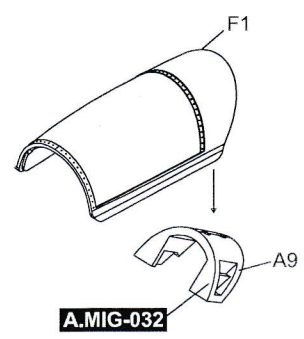
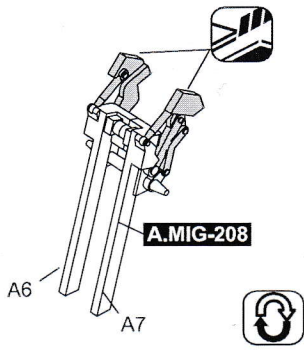
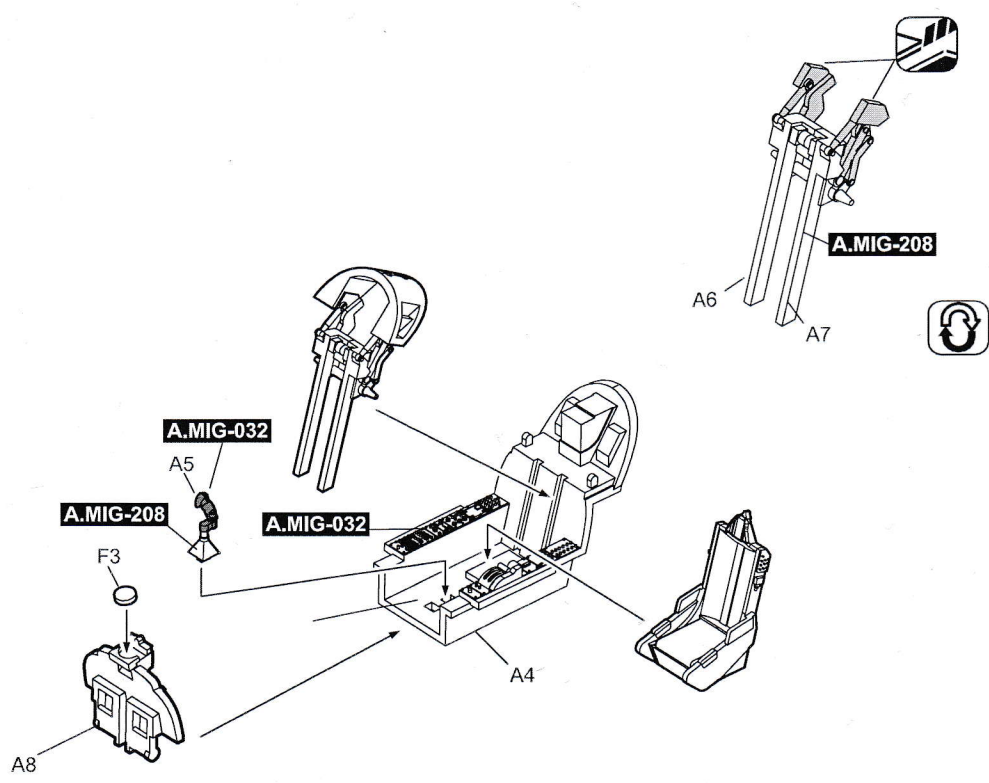

Canopy closed option

3

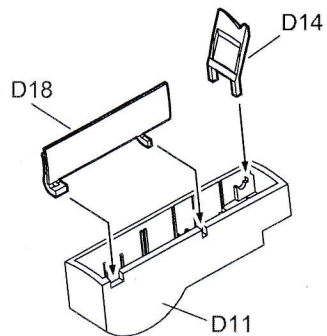
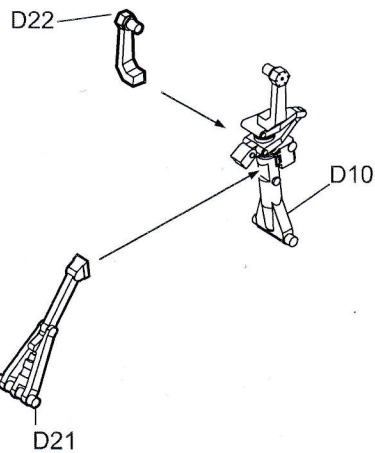
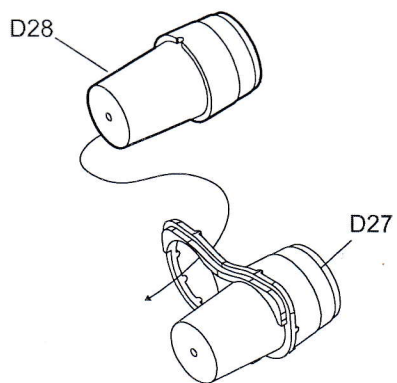
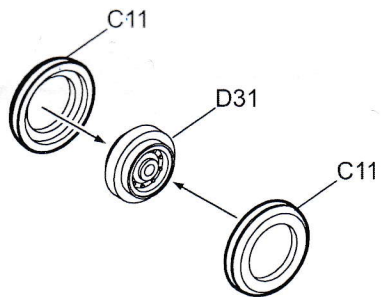

4

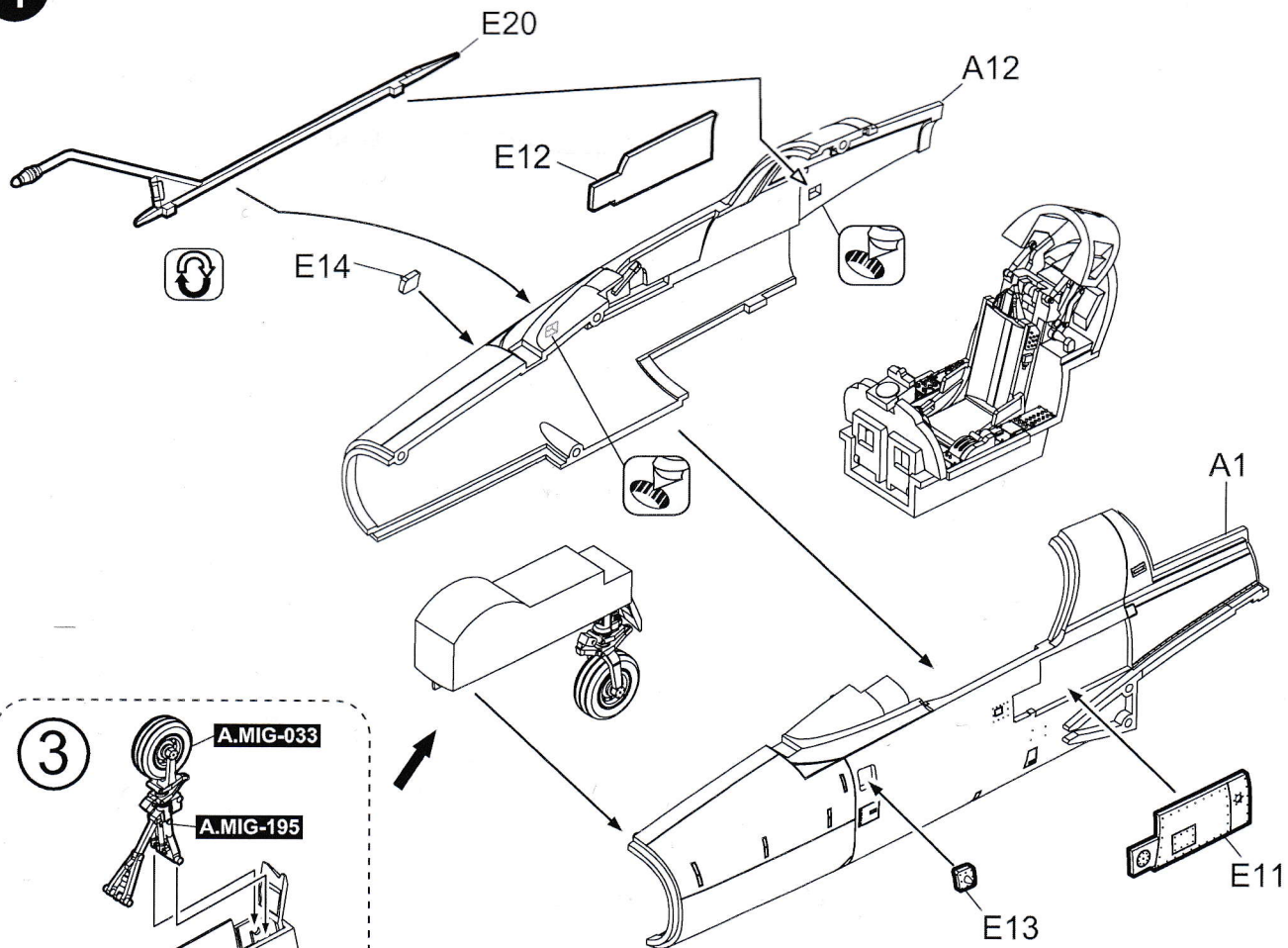

3

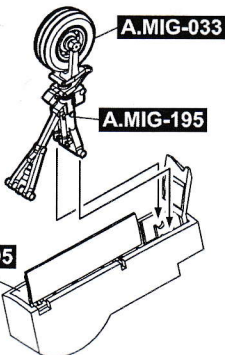

5

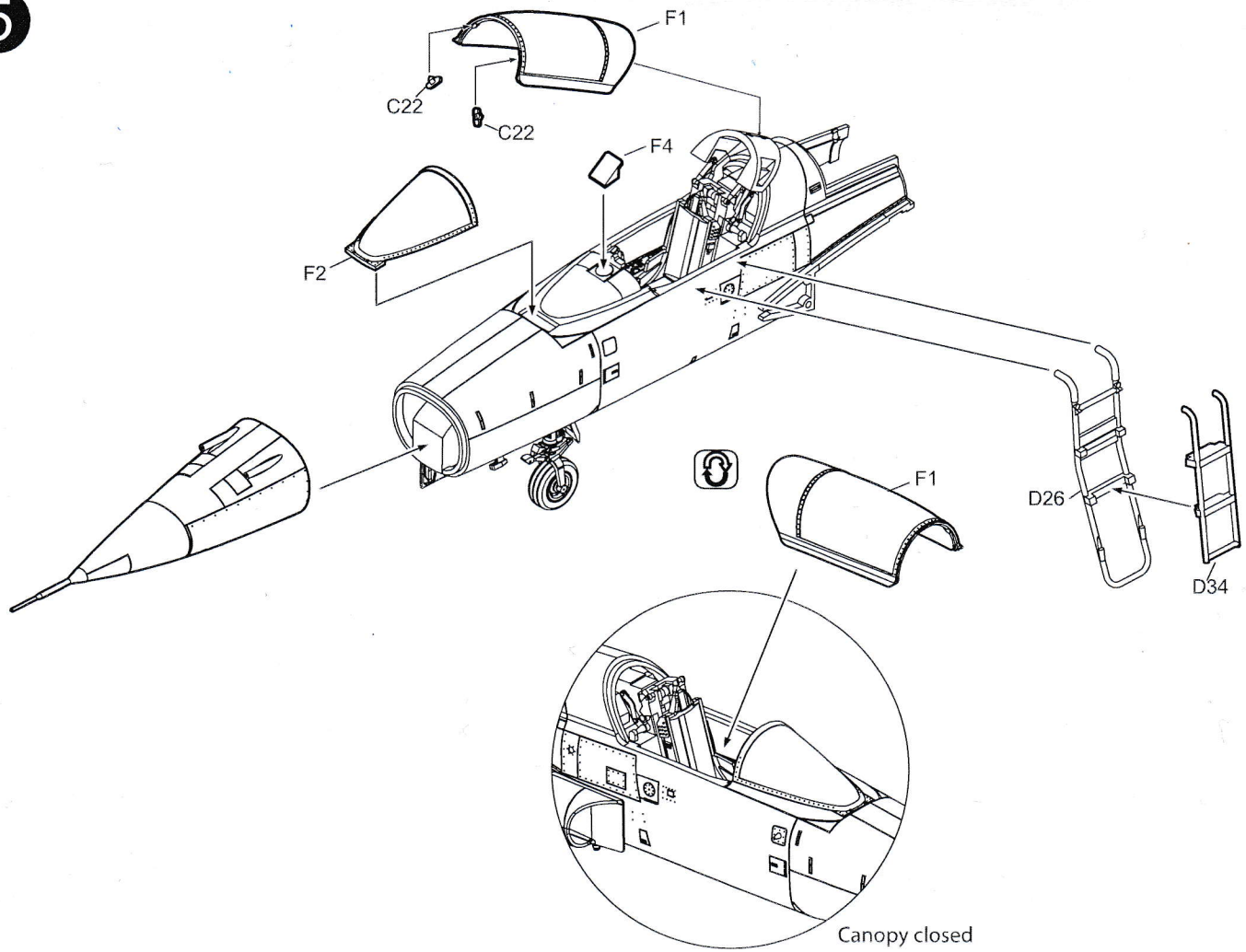

6

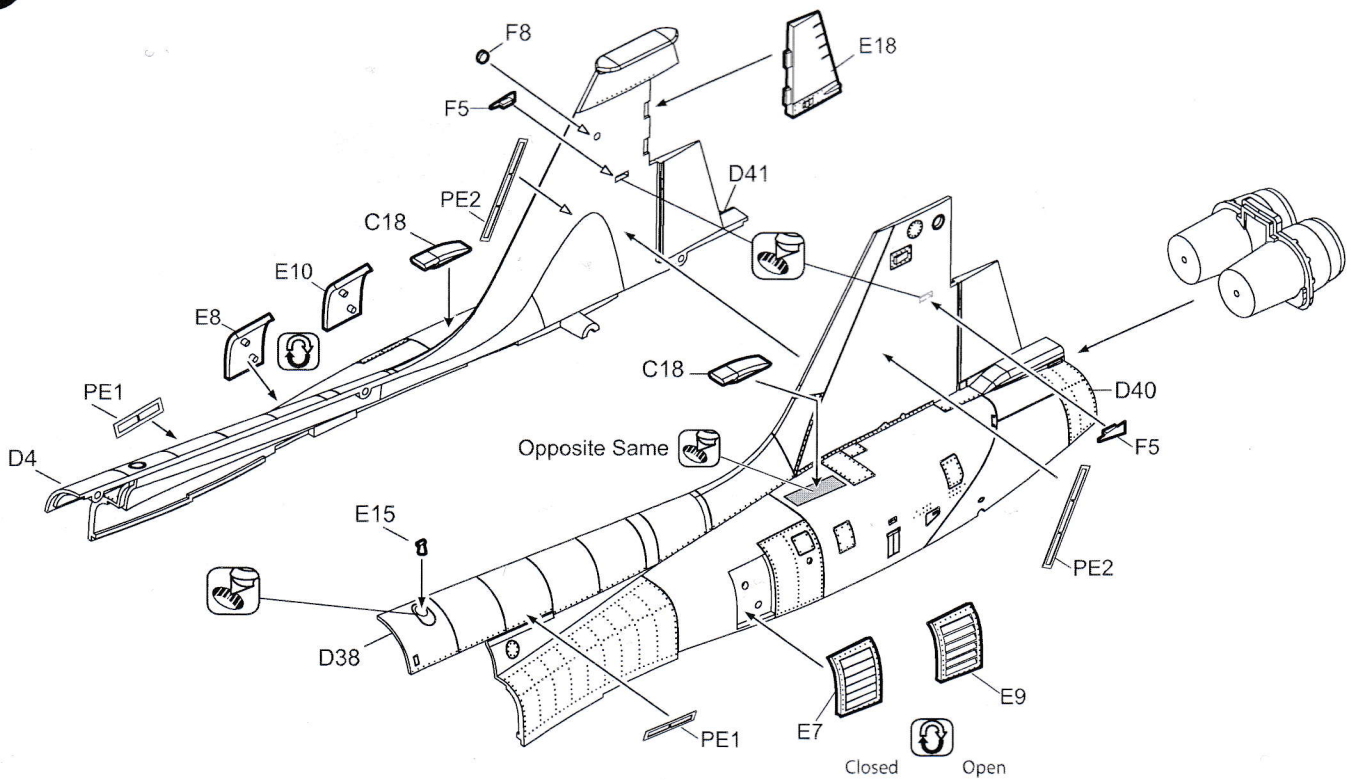

7

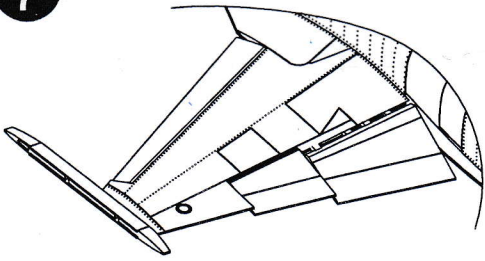

Flap Down

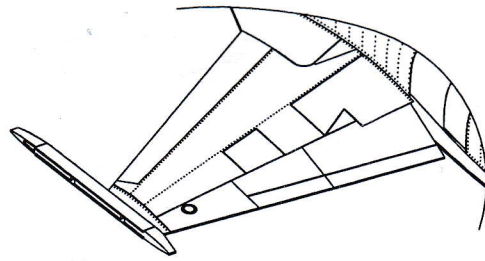

Flap Up

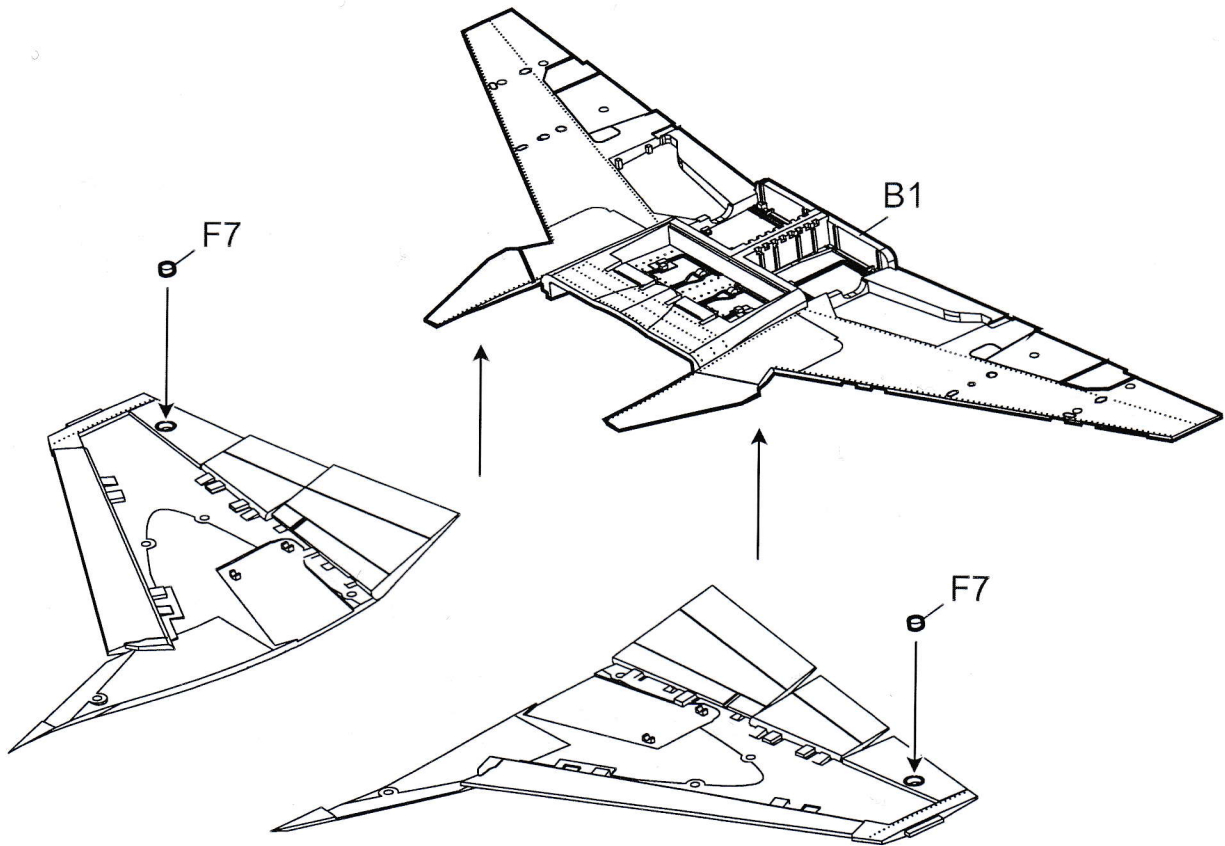
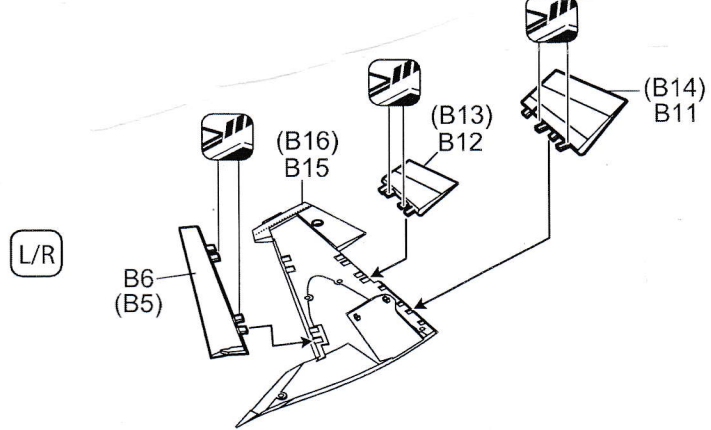
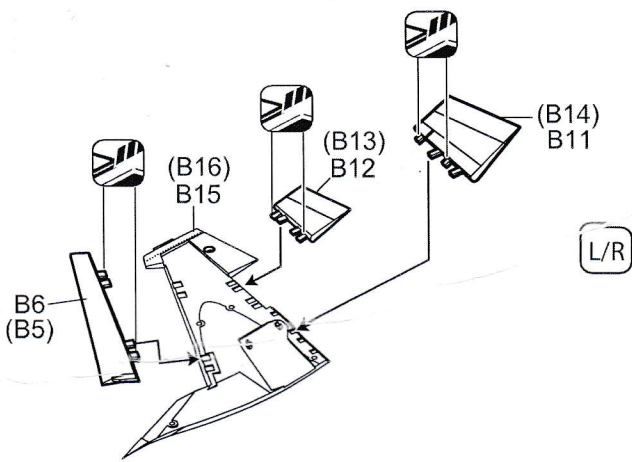

8

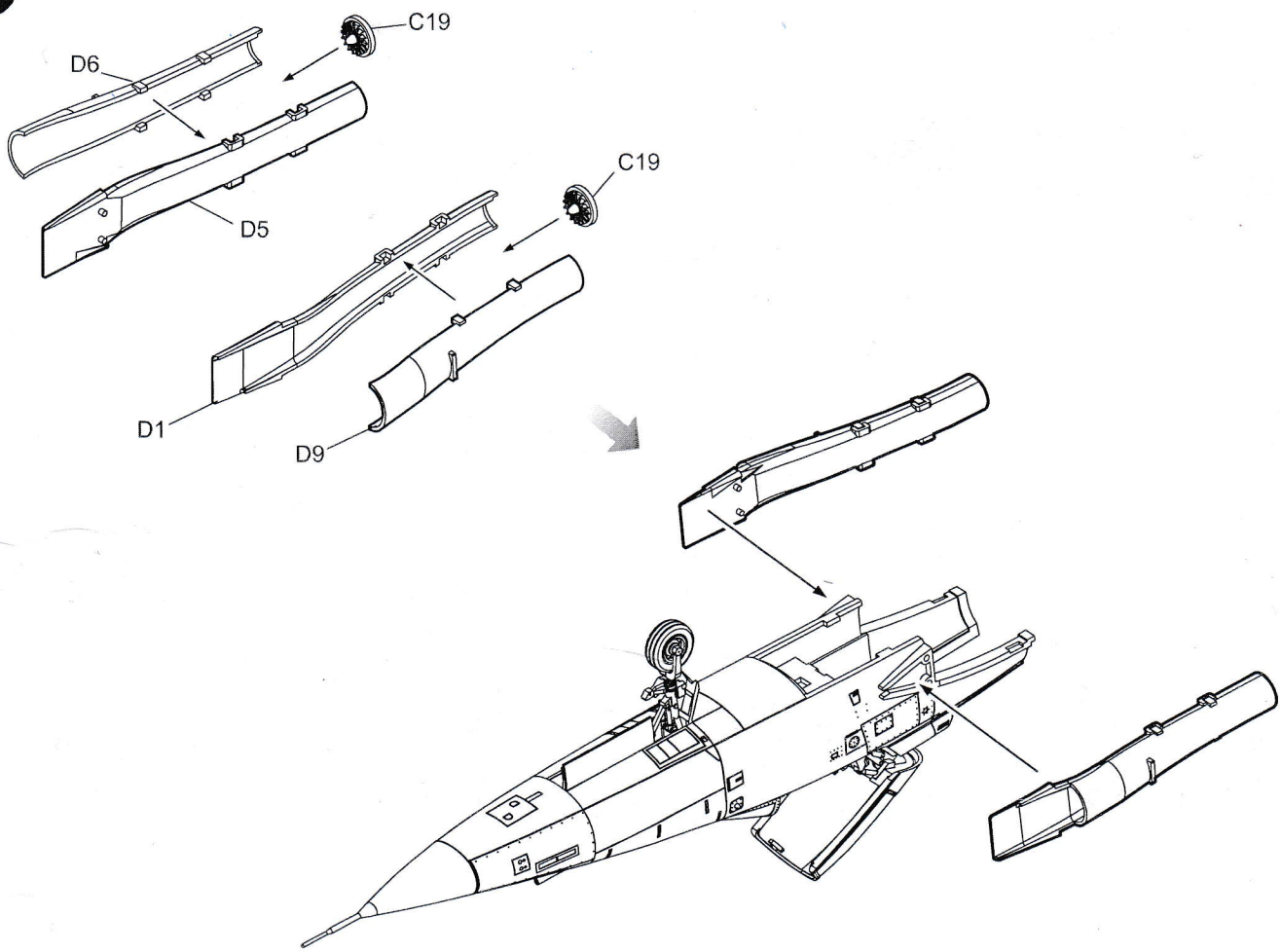

9

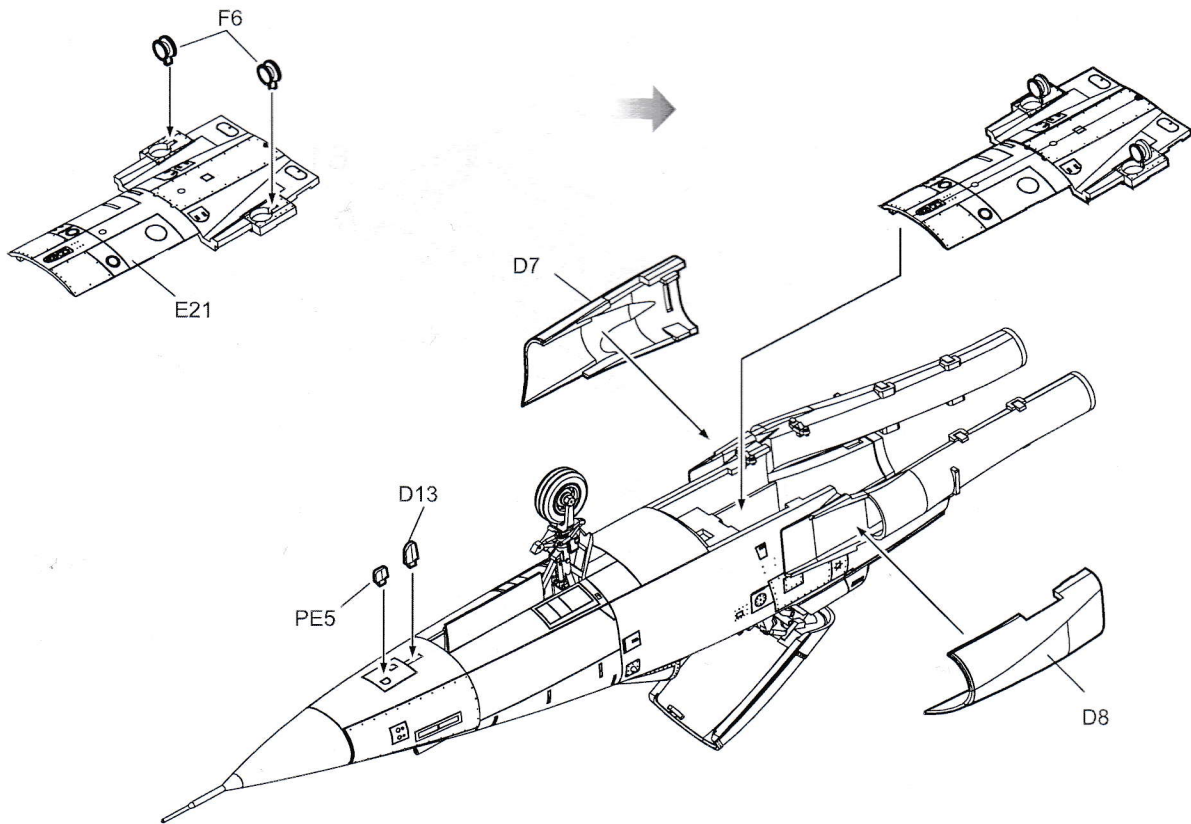

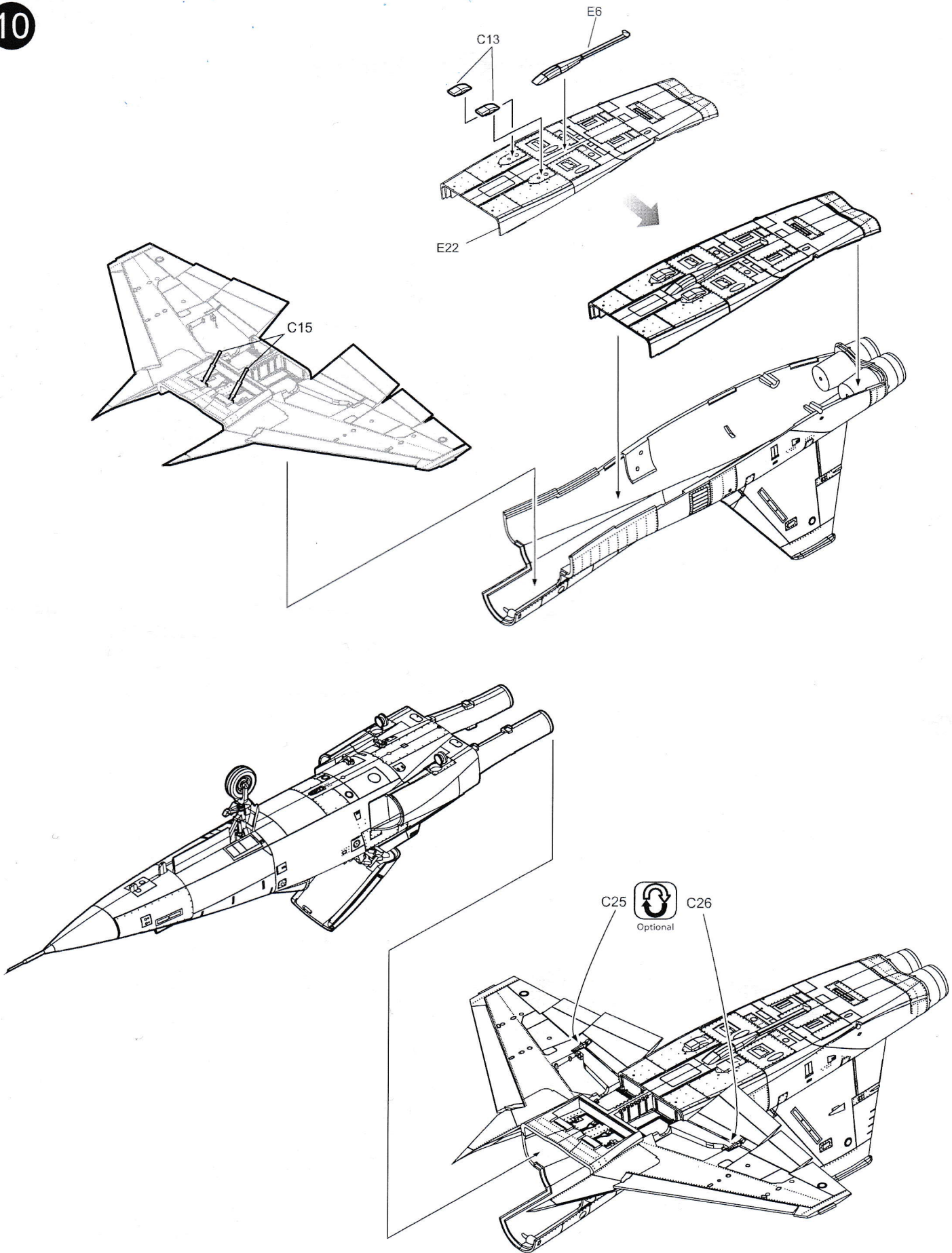

11

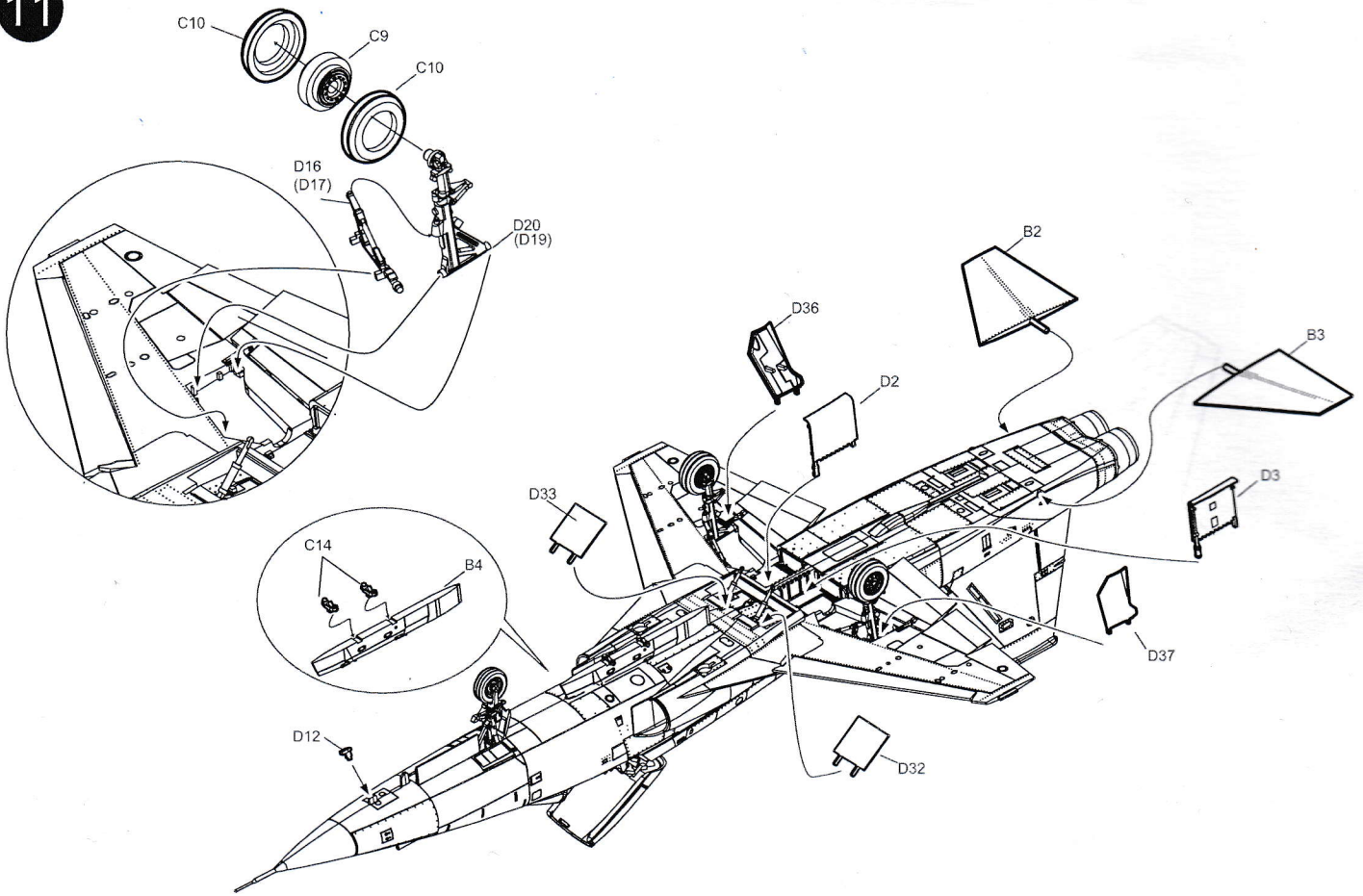

12

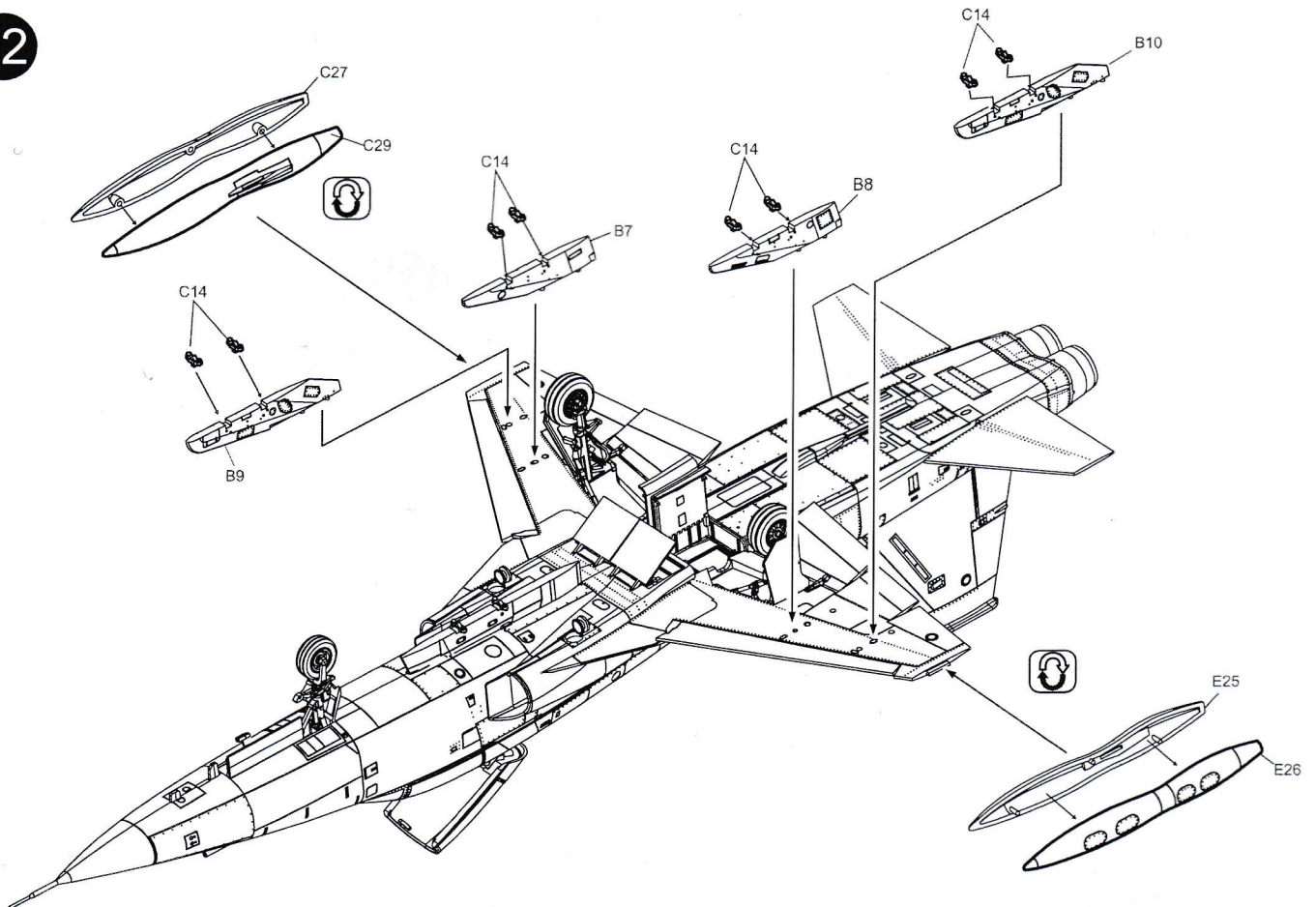

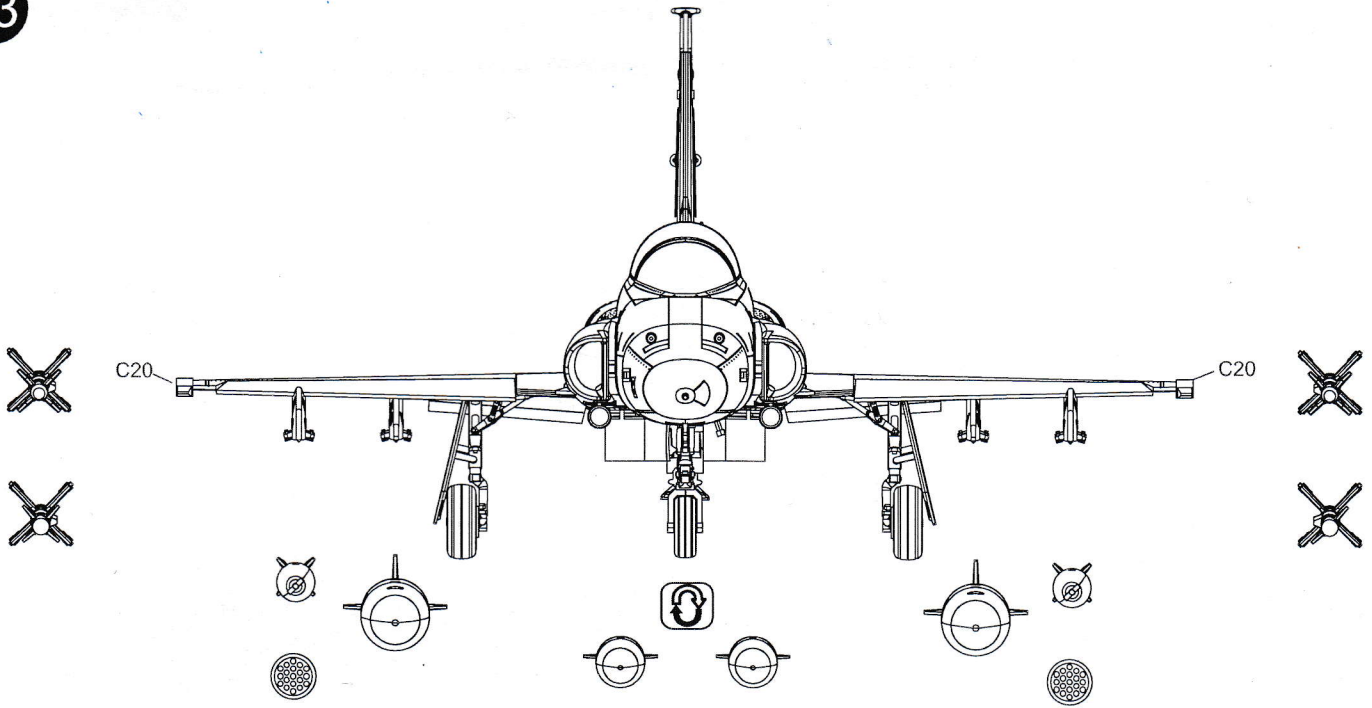

Centerline Fuel Tank #1

Fuel Tank

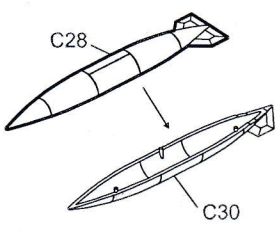

Rocket Launcher

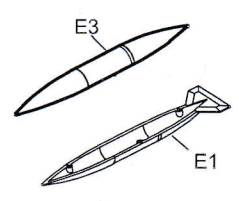
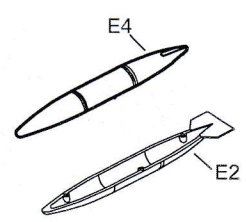
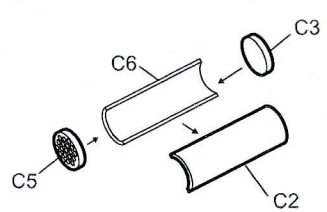

MK82

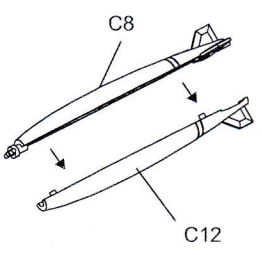

AIM-9B

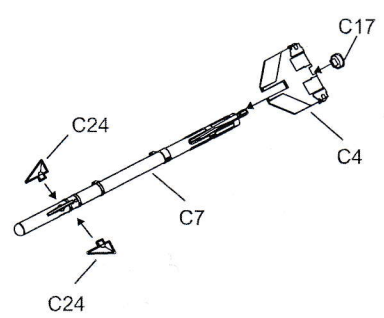

AIM-9J

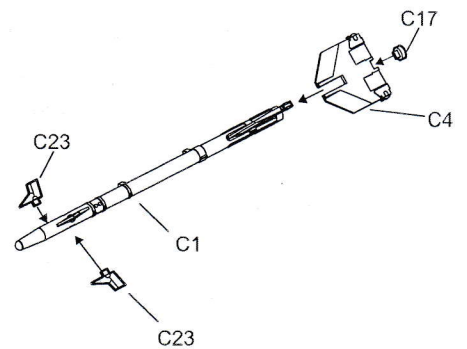

1/48 SCALE AIRCRAFT SERIES NO. K48109

1. Canadian Armed Forces CF-116 116757 / 116727, 1995.
116757 is stored in Canadian warplane heritage museum, wearing its last camouflage scheme at its retirement, 1995.

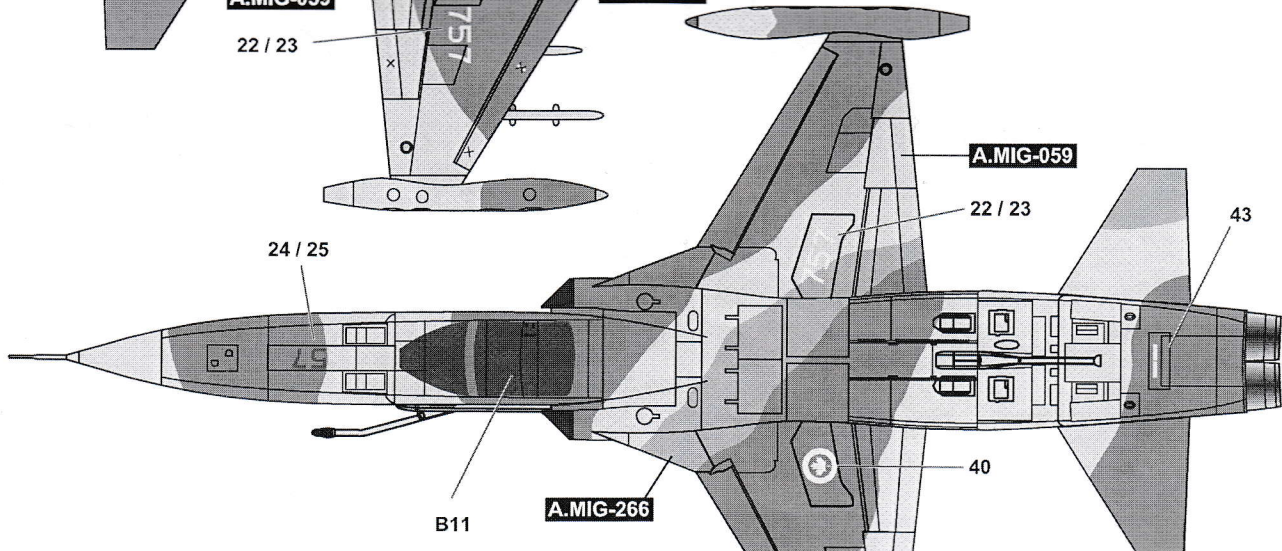
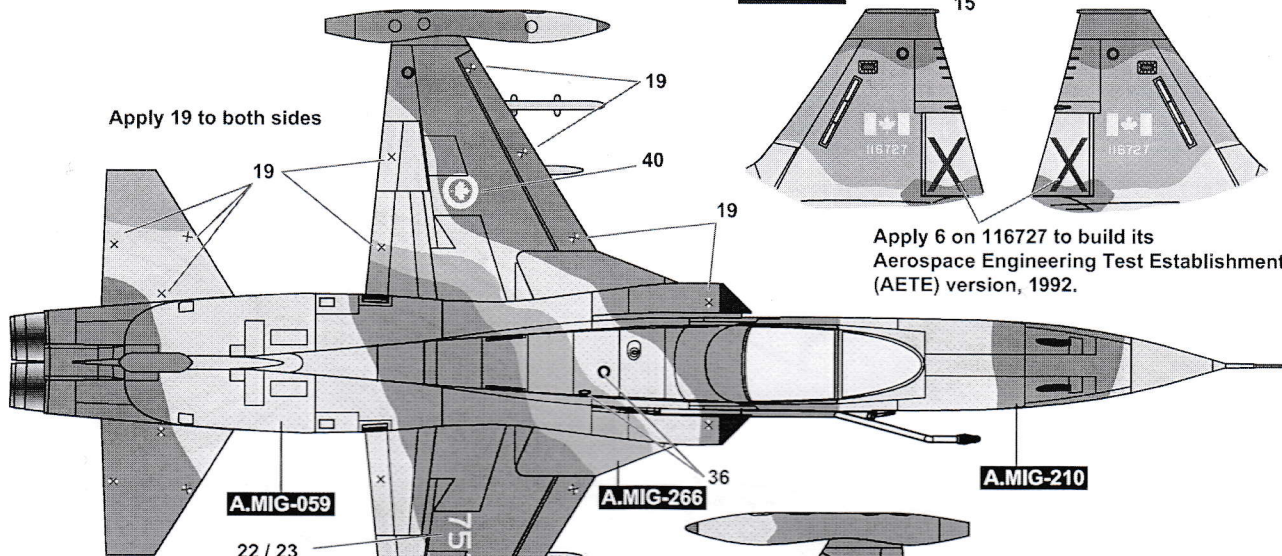
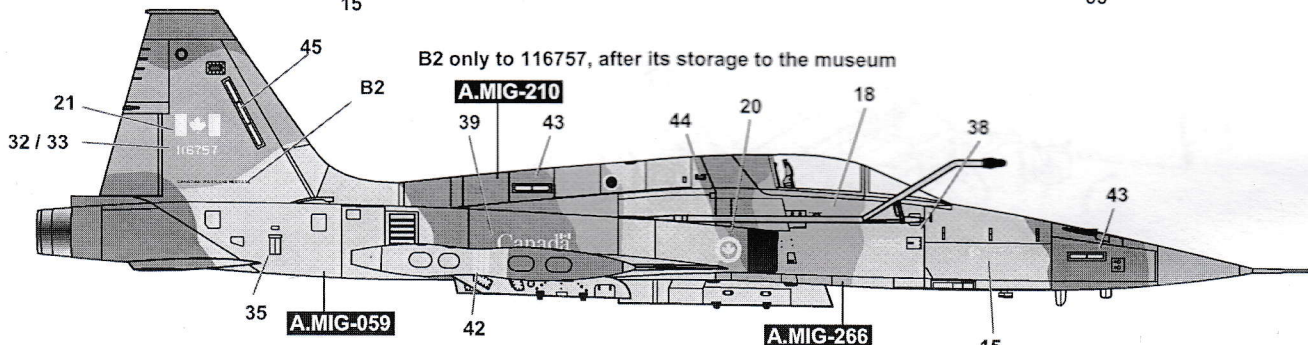
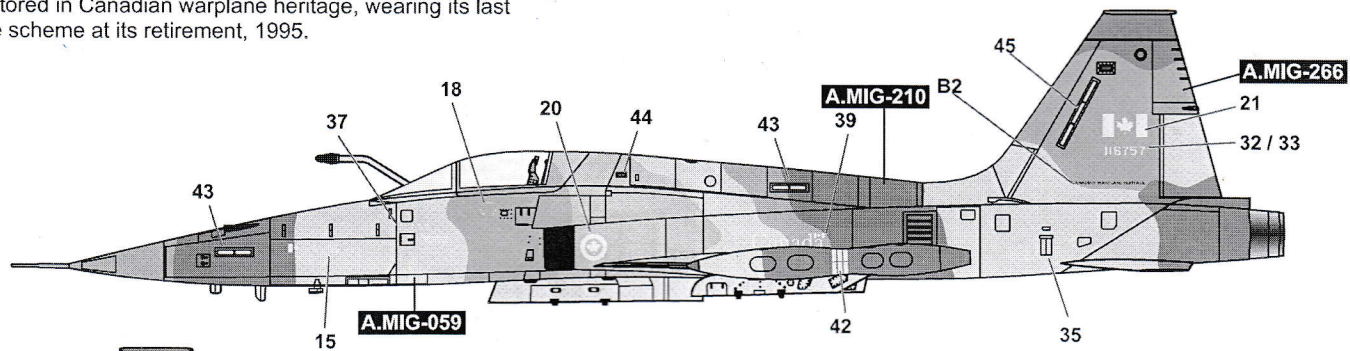

A.MIG-210 FS 35237 Blue Gray

A.MIG-266 FS 36307 Gray

A.MIG-059 FS 36251 Gray

1/48 SCALE AIRCRAFT SERIES NO K48109

2. Canadian Armed Forces CF-116 116763, No.434 "Bluenose" Squadron, in aggressor scheme, 1988. Retired and on exhibition at Canada Aviation and Space museum, Ottawa, Canada.

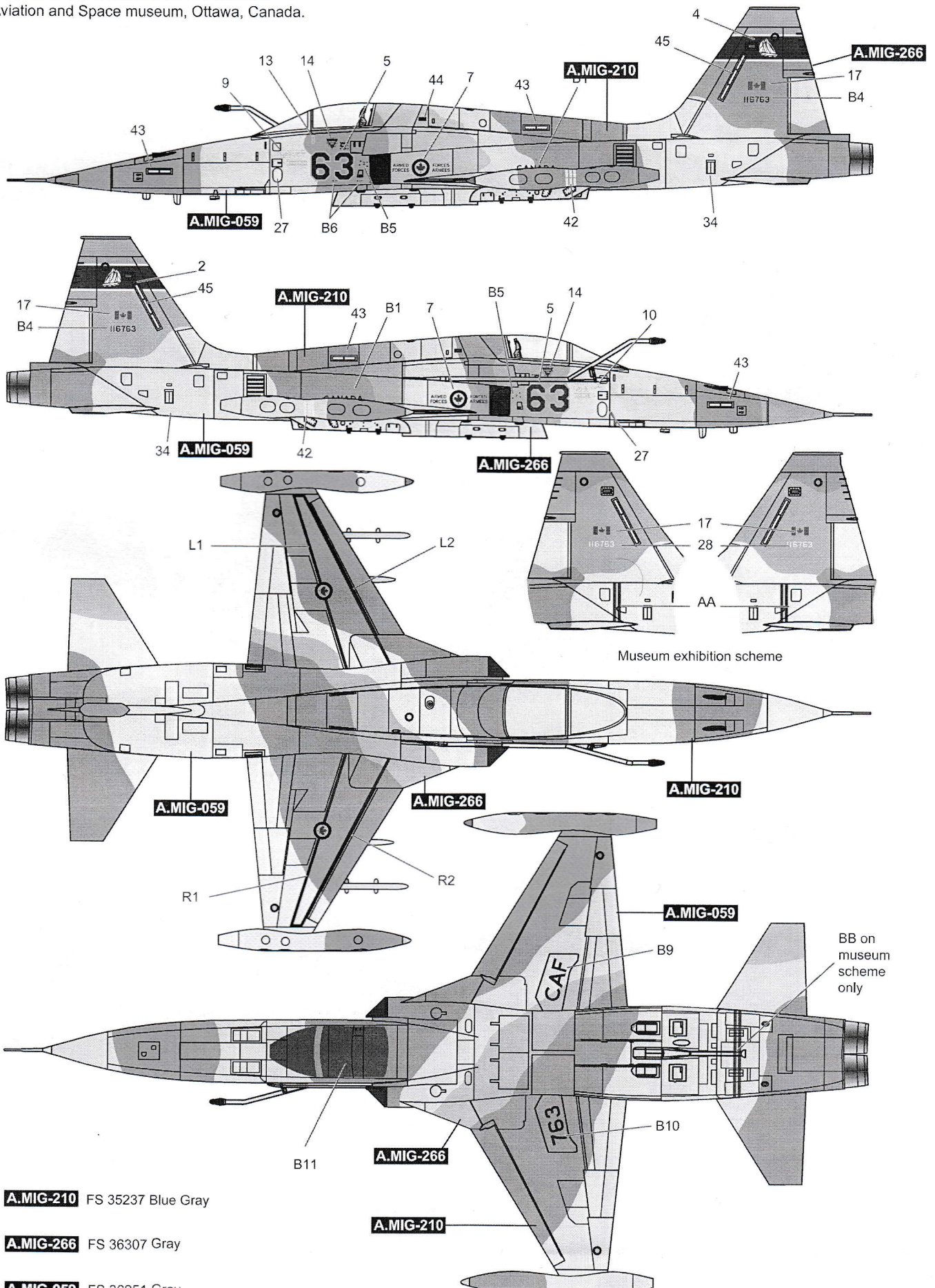

A.MIG-210 FS 35237 Blue Gray

A.MIG-266 FS 36307 Gray

A.MIG-059 FS 36251 Gray

1/48 SCALE AIRCRAFT SERIES NO.K48109

3. Canadian Forces CF-116, No.434 "Bluenose" Squadron, 1979.

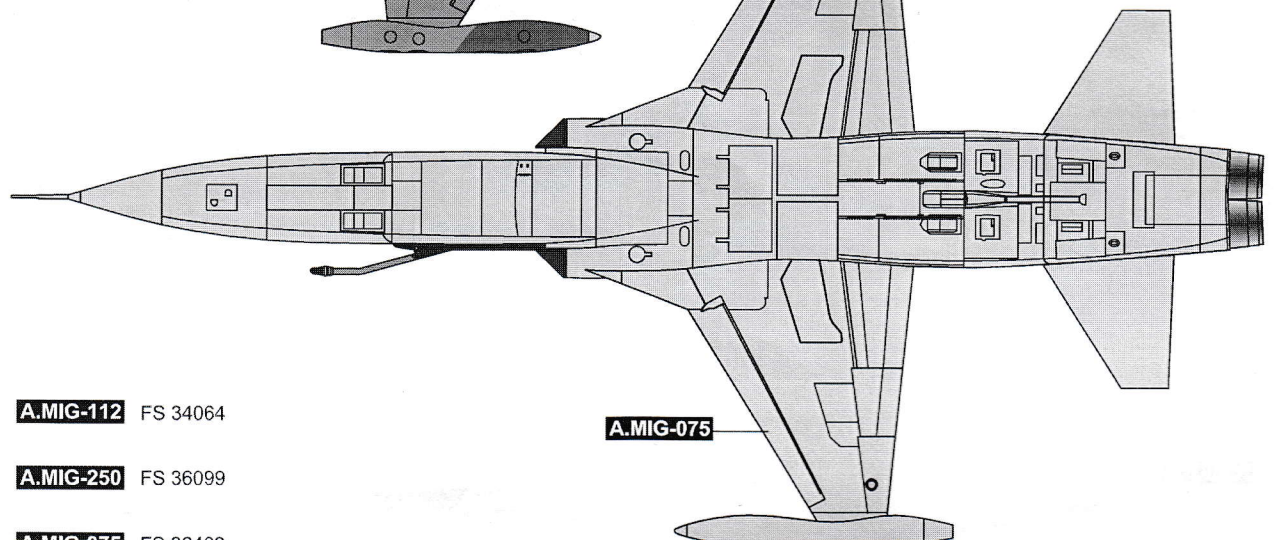
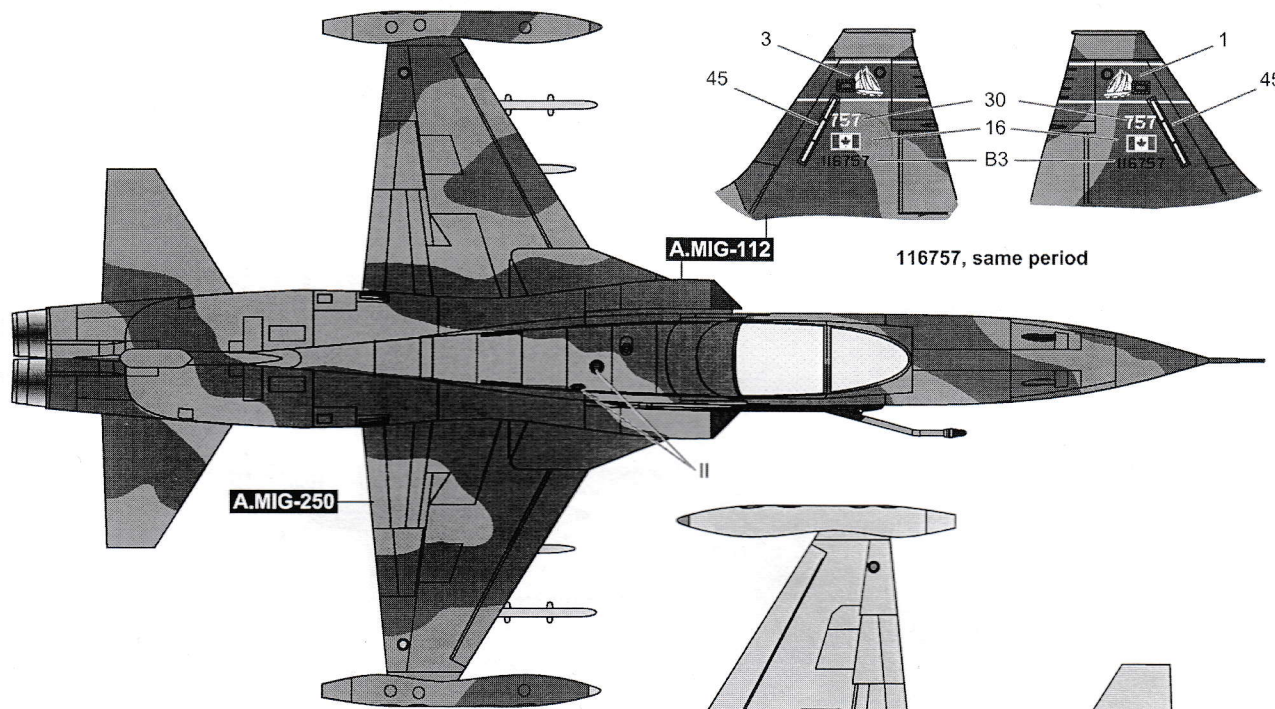
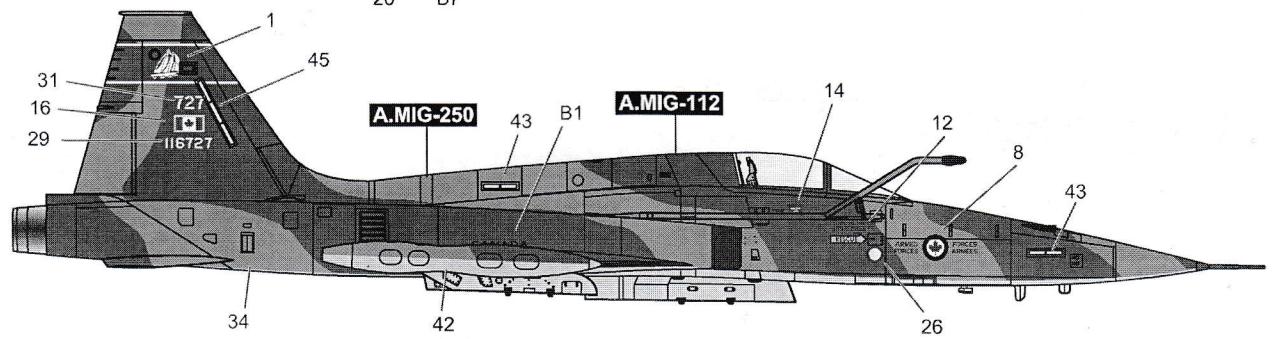
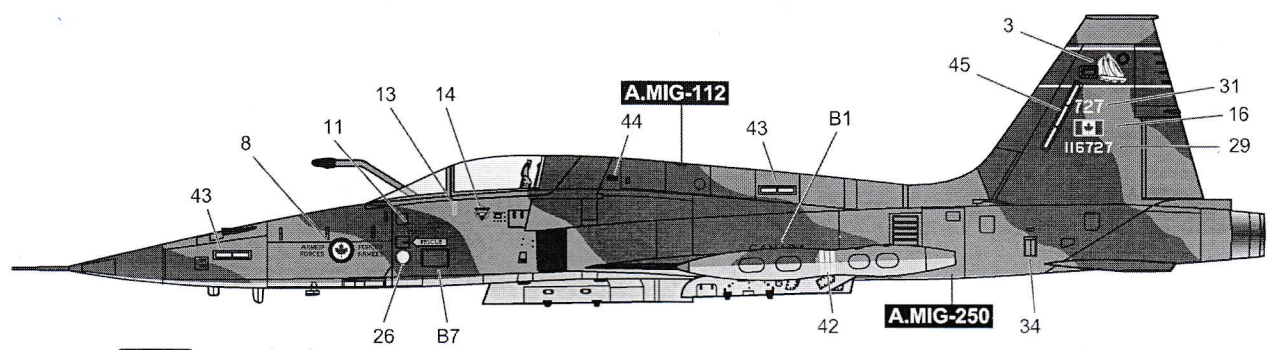

A.MIG-112 FS 34064

A.MIG-250 FS 36099

A.MIG-075 FS 02400