



A-26C-15 «Инвейдер»

Американский бомбардировщик II МВ

Дуглас А-26 «Инвейдер» был лучшим американским двухмоторным бомбардировщиком II Мировой войны. Он имел высокие летные характеристики и мощное вооружение. А-26 производился в 1942-1945 г. Всего было выпущено 1355 самолетов А-26В со «сплошным» носом (6-8 12,7-мм пулеметов Браунинг) и 1091 А-26С с «остекленным», в котором находилось место штурмана-бомбардира.

Бомбардировщики А-26 активно применялись в Западной Европе, Италии и на Тихом океане в 1944-1945 г. До последних дней Второй мировой войны они использовались для атак тылов противника, железных и автомобильных дорог.

Тактико-технические характеристики А-26С-15

Длина, м	15,62
Размах крыла, м	21,34
Нормальный взлетный вес, кг	11793
Двигатель	2x Pratt Уитни R-2800, 2000 л.с.
Максимальная скорость, км/ч	457
Потолок, м	6736
Дальность, км	1400
Вооружение	До 12x12,7-мм пулеметов Браунинг, до 2710 кг бомб

ВНИМАНИЕ!

Перед сборкой внимательно прочитайте руководство по монтажу. Каждая деталь пронумерована. Соблюдать последовательность монтажа. Необходимые рабочие инструменты: нож и напильник для зачистки деталей; резиновая лента, клейкая лента и зажимы для сушки белья для прижимания склеиваемых деталей. Детали из пластика очистить в растворе мягкого моющего средства и высушить на воздухе для того, чтобы краска и переводные картинки лучше прилипали. Перед приклеиванием проверить, подходят ли детали; клей наносить экономно. Хром и краску удалить с поверхностей склеивания. Небольшие детали покрасить перед тем, как они будут удалены из рамок. Краску необходимо хорошо просушить, только после этого продолжать сборку. Каждую соответствующую переводную картинку отдельно вырезать и примерно на 20 секунд окунуть в теплую воду. На обозначенном месте картинку отделить от бумаги и прижать промокающей бумагой.

A-26C-15 Invader

WWII American Bomber

Douglas A-26 Invader was the best WWII American twin-engine bomber. It had high flight data and carried powerful weapons. It was produced in 1942-1945. There were produced 1355 A-26B aircraft with solid nose (6-8 12,7 mm Browning MG) and 1091 A-26C aircraft with glassed nose in which was the place of the bomber navigator.

A-26 bombers had active service in the Western Europe, Italy and Pacific in 1944-1945.

They were used to the last day of this WWII for attack on the enemy's rear lines, railways and highways.

Tactical and Technical Specifications of A-26C-15

Length, m	15,62
Span, m	21,34
Start Weight, kg	11793
Engine	2x Pratt Whitney R-2800, 2000 hp
Max. Speed, km/h	457
Service ceiling, m	6736
Range, km	1400
Armament	Up to 12x12,7 mm Browning MG, bomb load - up to 2710 kg

CAUTION!

Read the instructions thoroughly prior to assembly. Each component is numbered. Adhere to specified sequence of assembly. Tools required: knife and file for removal of components from frame; rubber bond, adhesive tape and clothes pegs for clamping components together after applying adhesive. Clean plastic components in a mild detergent solution and allow to air-dry so that paint and transfers adhere better. Prior to applying adhesive, check to see whether the components fit together; apply adhesive sparingly. Remove chrome and paint from the contact surfaces. Paint small components before removing them from the frame. Allow paint to dry well, and only then continue to assemble. Cut out each transfer individually and immerse in warm water for approx. 20 seconds. Slide transfer off paper and into designated position, then press on with blotting paper.

ИСПОЛЗУЕМЫЕ КРАСКИ / USED COLORS:

	Revell	Tamiya		
A	142	XF62	Оливковый, матовый	Olive Drab
B	302	X18	Черный, полуматовый	Semigloss Black
C	199	XF16	Алюминий	Aluminium
D	115	XF3	Желтый, матовый	Flat Yellow
E	156	XF8	Синий, матовый	Flat Blue
F	143	XF20	Серый, матовый	Flat Grey
G	360	XF5	Зеленый, матовый	Flat Green

	Revell	Tamiya		
H	190	X11	Серебристый	Chrome Silver
J	191	X32	Сталь	Steel
K	109	X10	Темный металл	Gun Metal
L	108	XF1	Черный, матовый	Flat Black
M	731	X27	Красный, прозрачный	Clear Red
N	161	X25	Зеленый, прозрачный	Clear Green
P	105	XF2	Белый, матовый	Flat White

01 СТАДИЯ СБОРКИ
ASSEMBLY STEP

03 СБОРОЧНАЯ ЕДИНИЦА
ASSEMBLY UNIT

■ ПРИ СБОРКЕ НЕ ИСПОЛЗУЕТСЯ
PARTS NOT FOR USE

☒ НЕ КЛЕИТЬ
DO NOT CEMENT

☒ ПРОСВЕРЛИТЬ
OPEN HOLE

? ПРОИЗВОЛЬНЫЙ ВЫБОР
OPTIONAL

A ИСПОЛЗУЕМАЯ КРАСКА
USED COLOR

x2 СДЕЛАТЬ ДВЕ ДЕТАЛИ
MAKE 2 PCS

***** СДЕЛАТЬ САМОМУ
SCRATCH BUILD

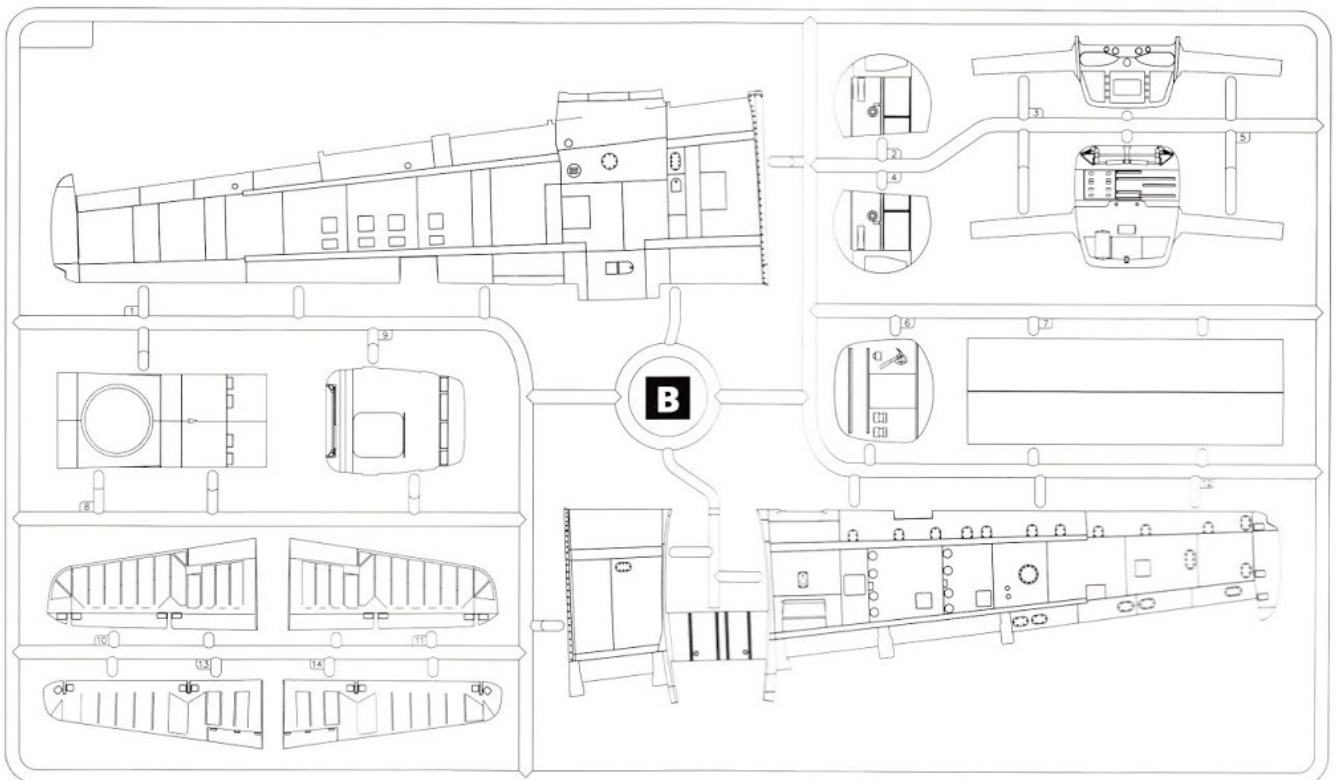
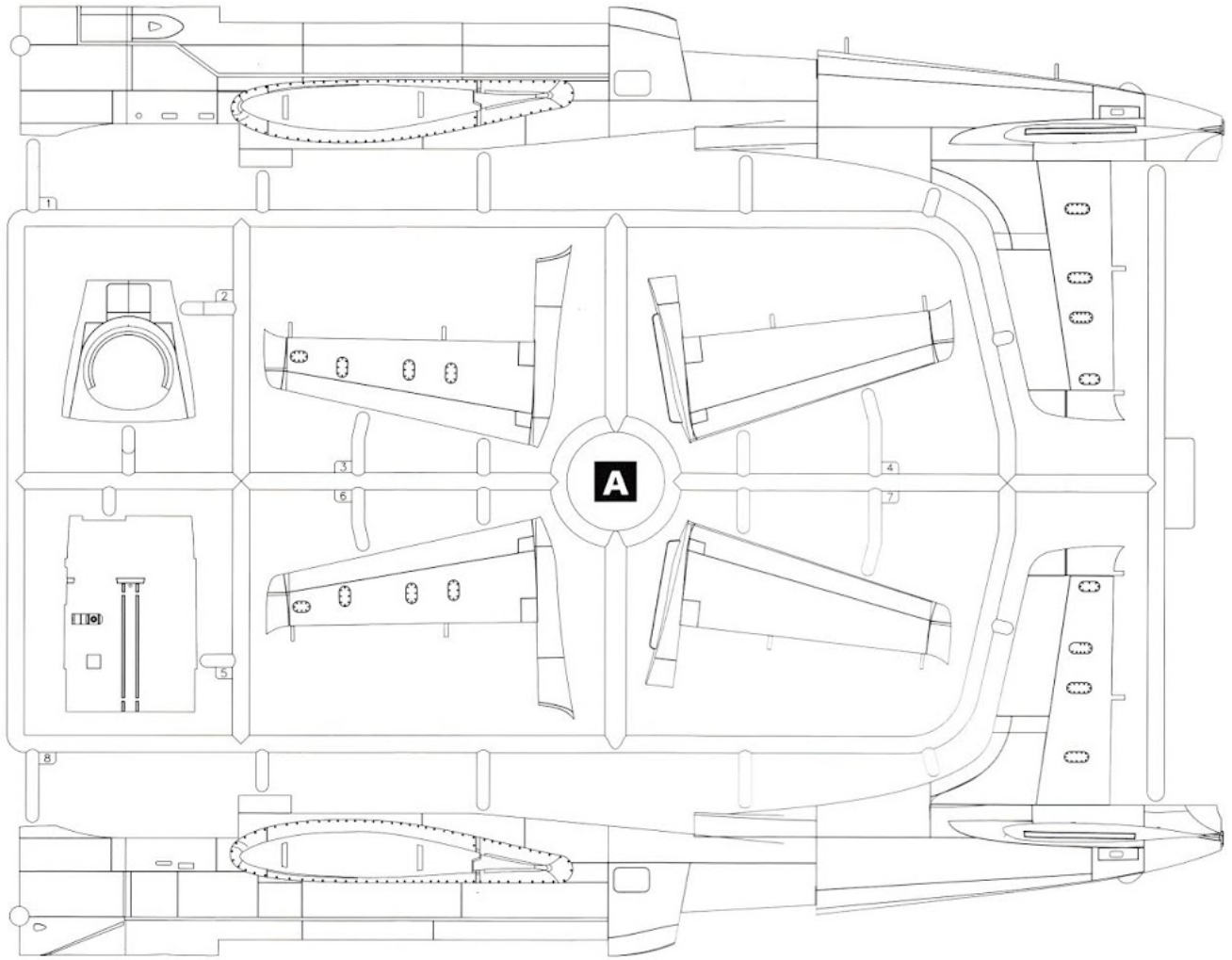

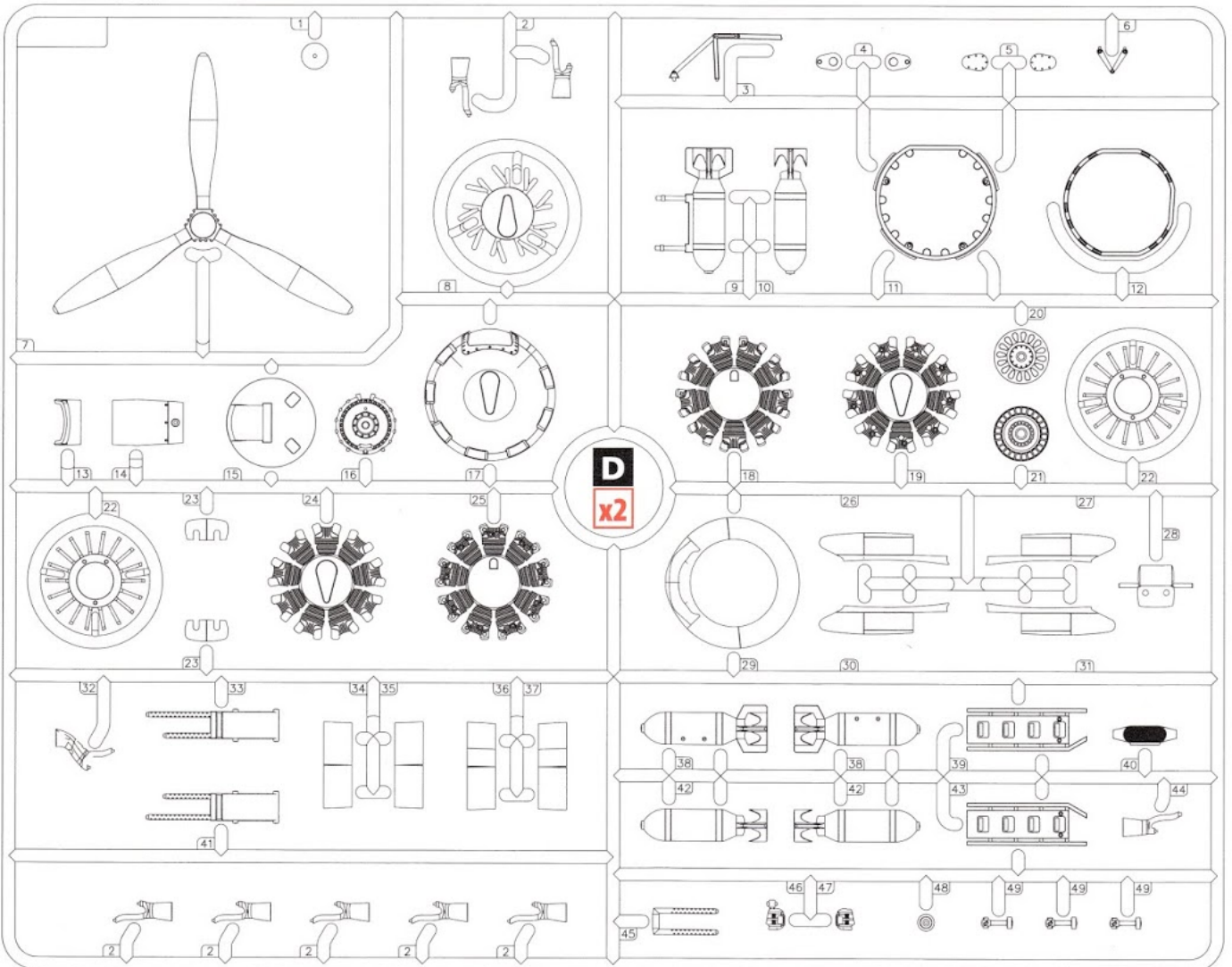
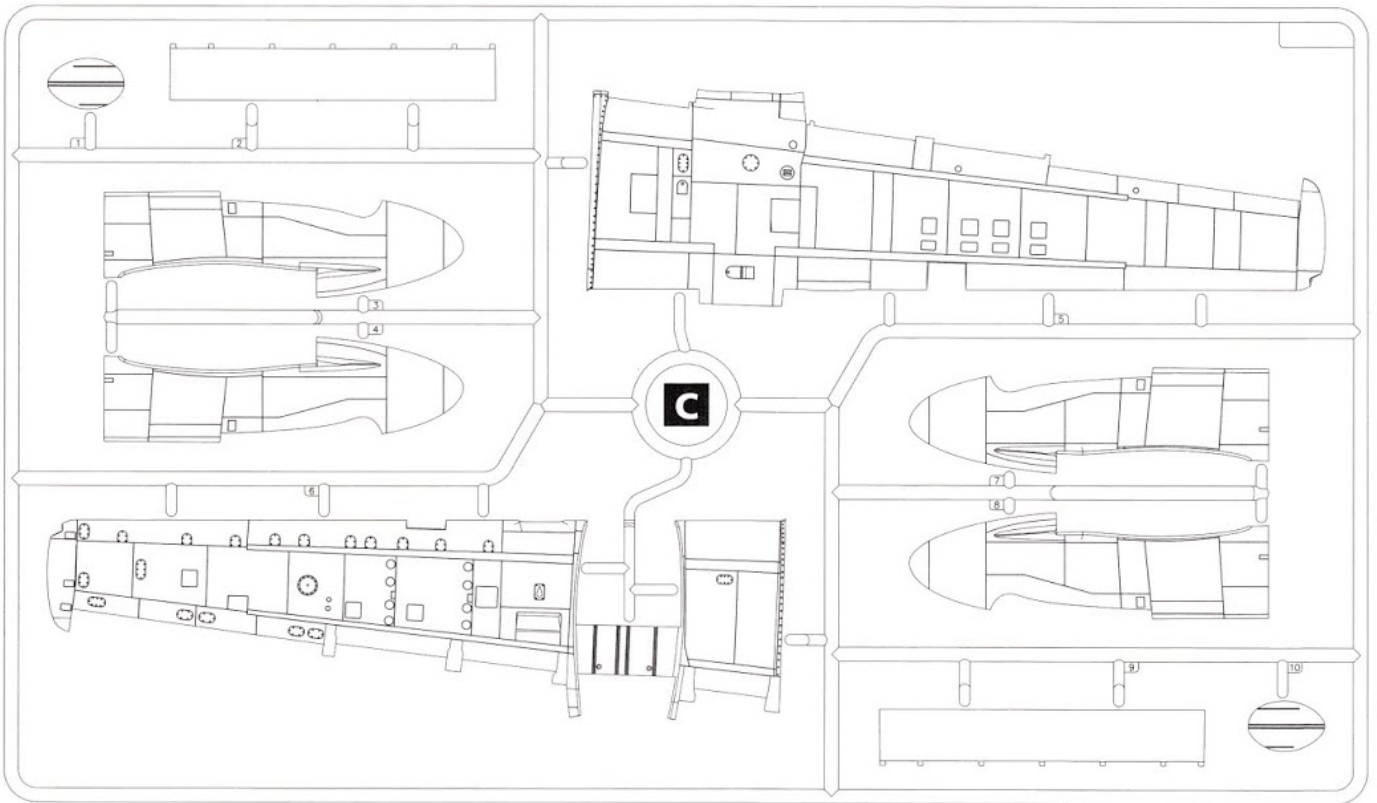

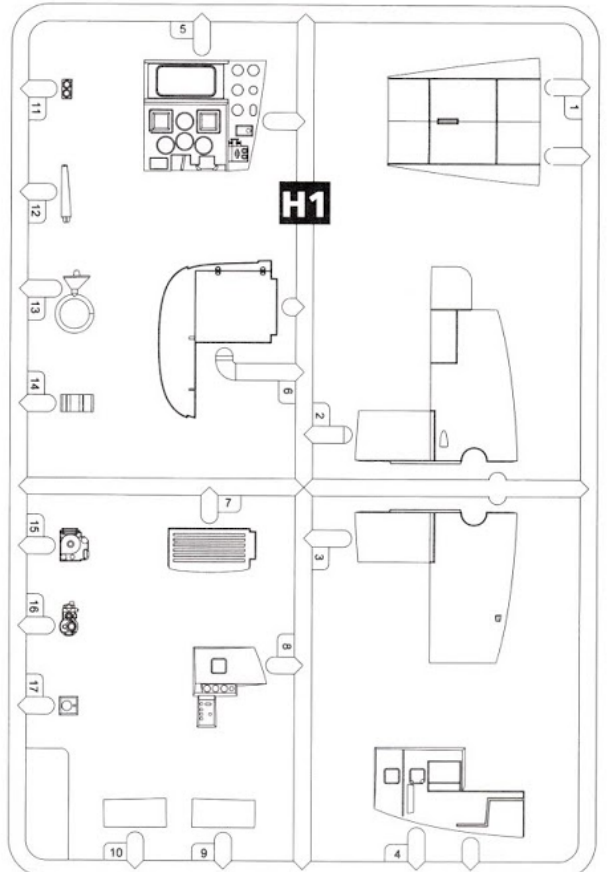
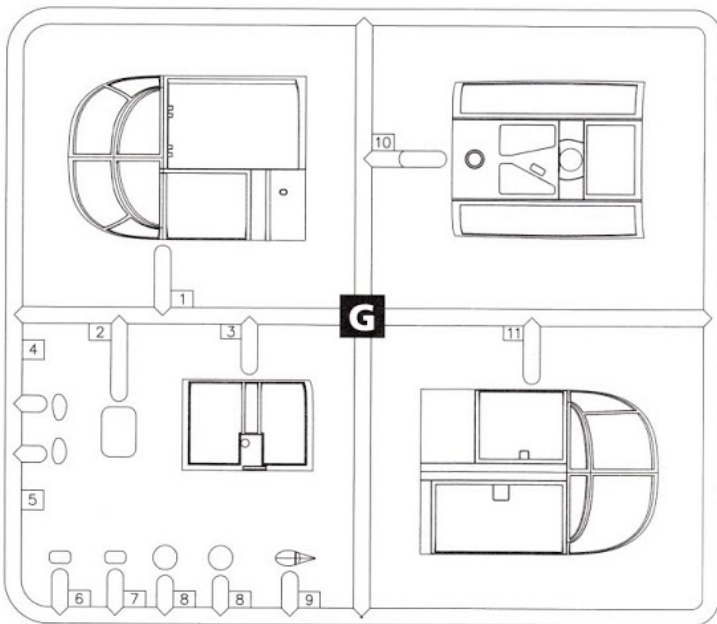
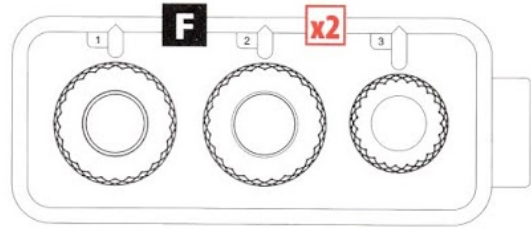
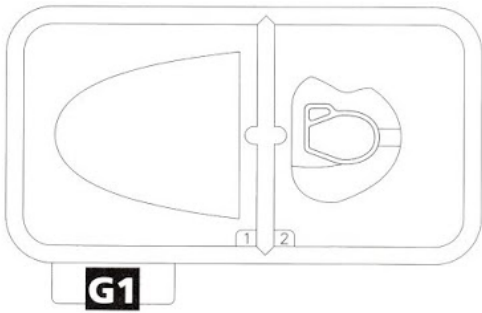
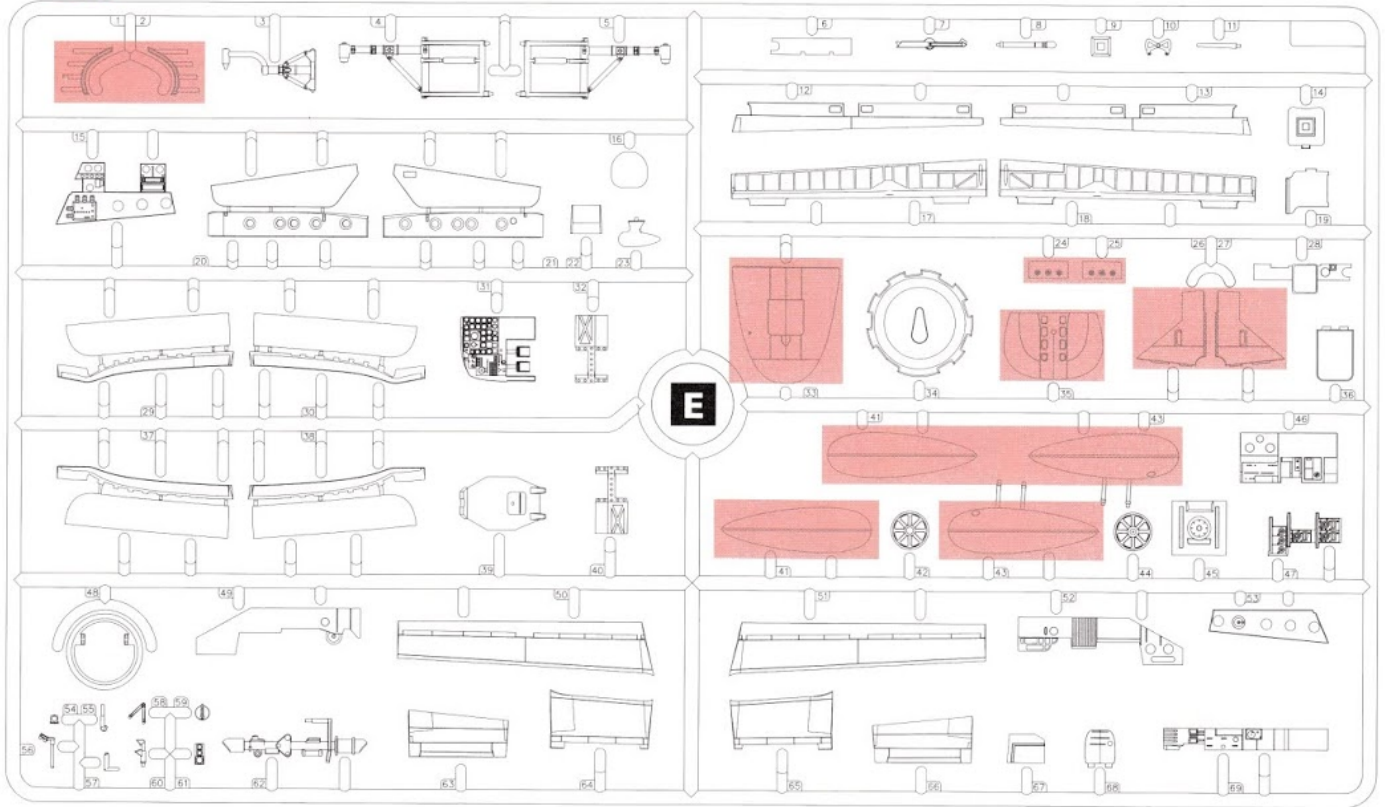

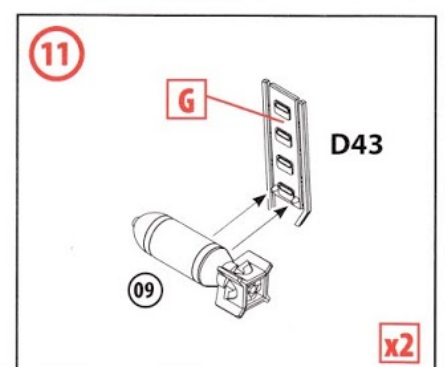
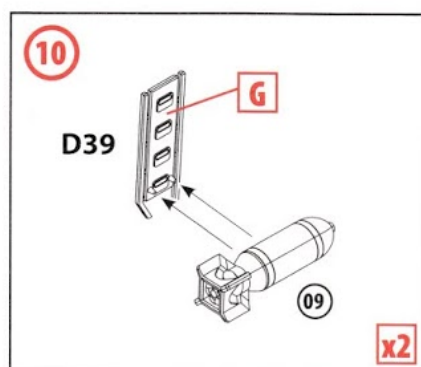
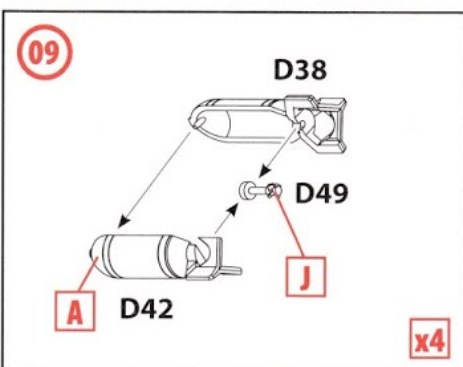
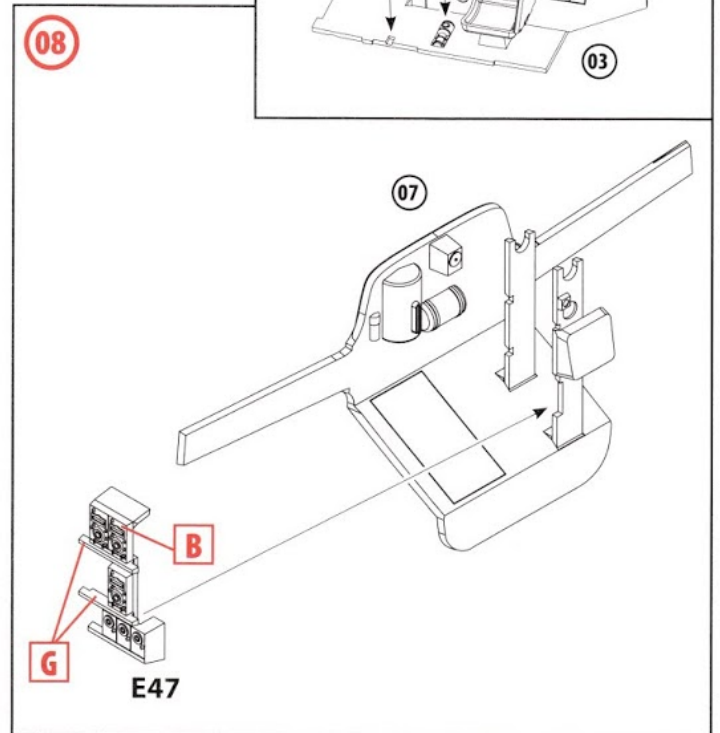
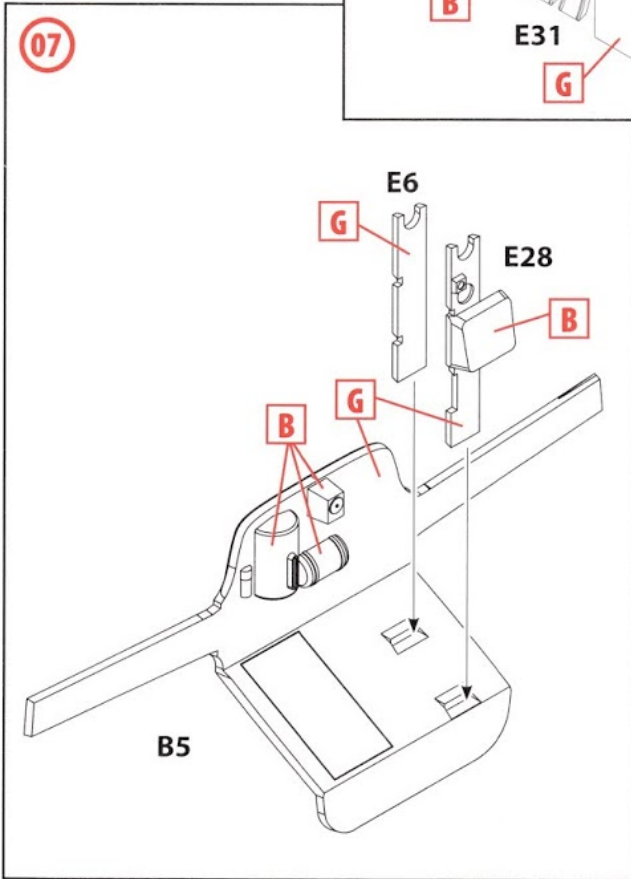
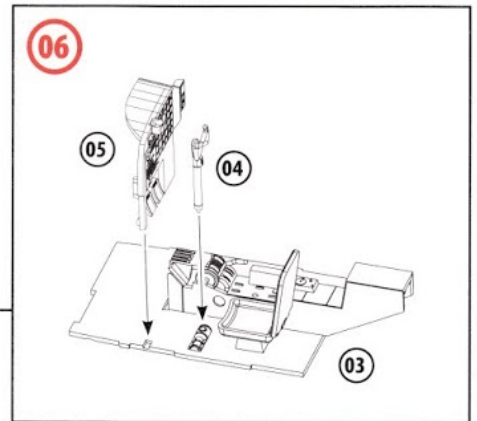
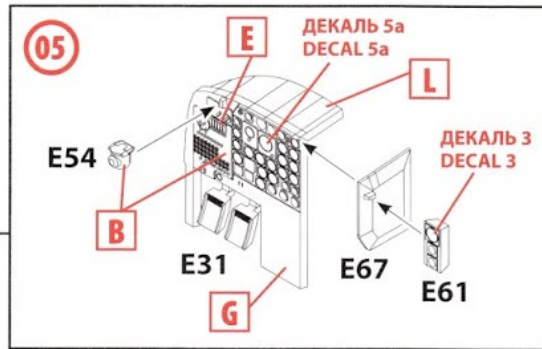
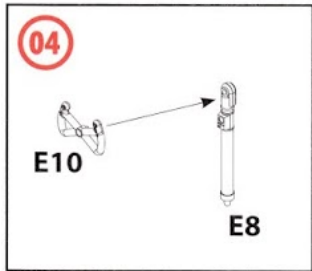
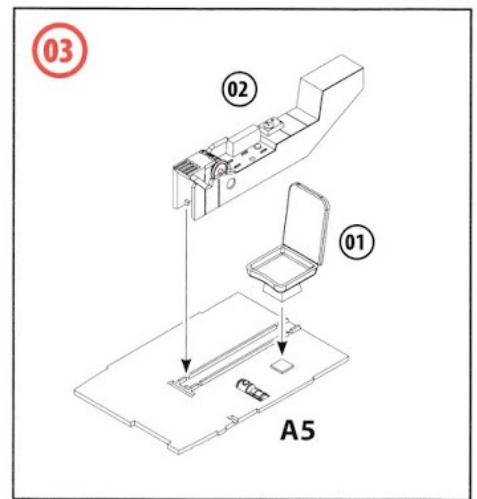
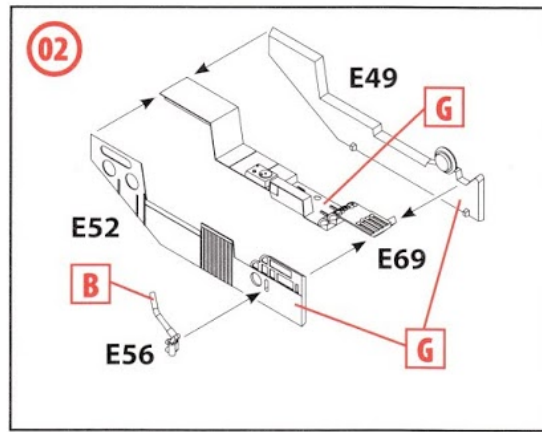
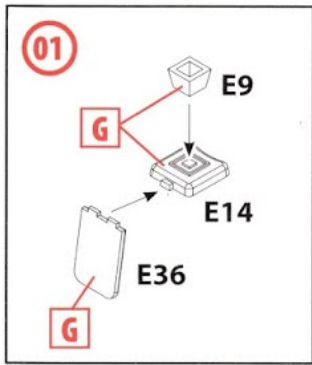

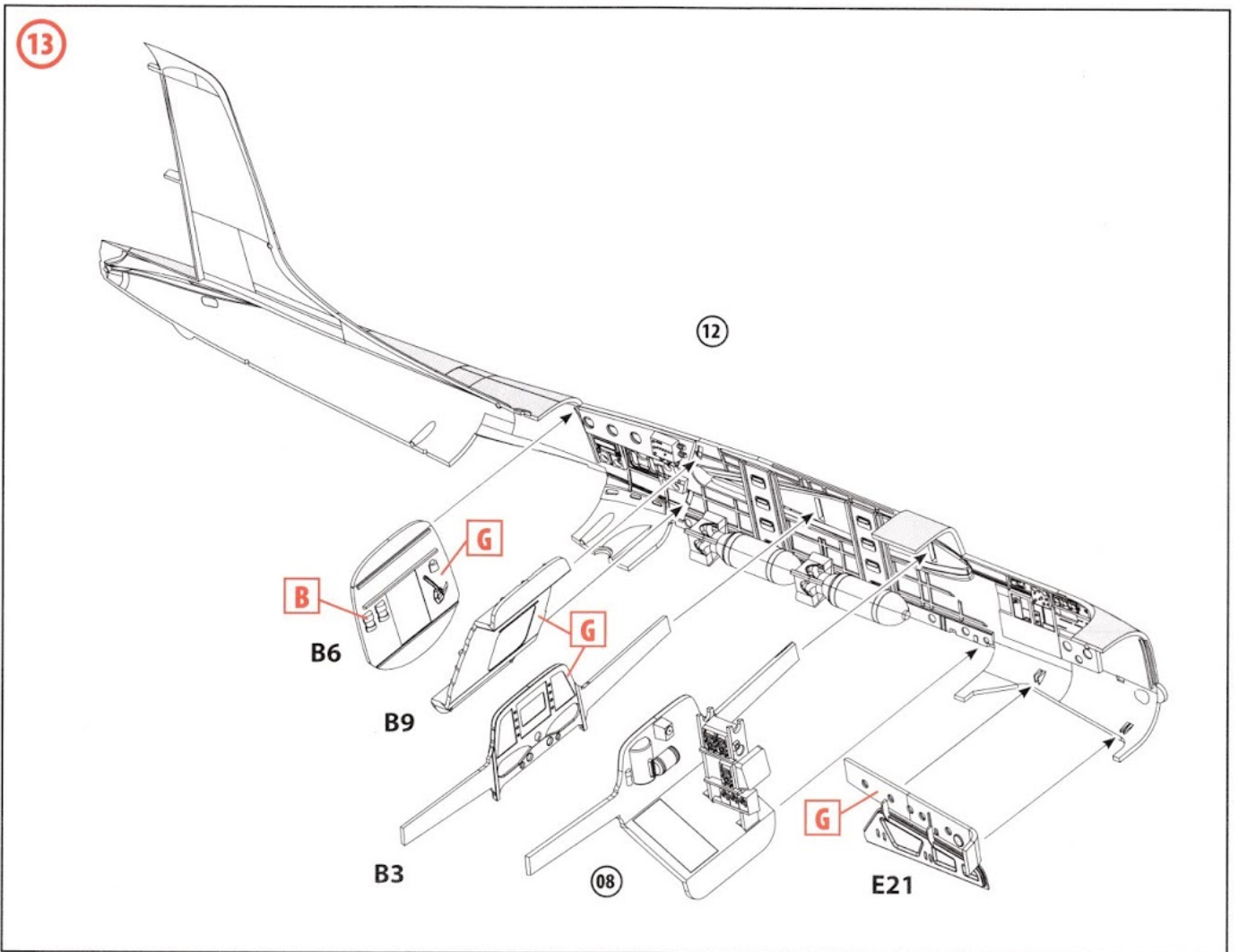
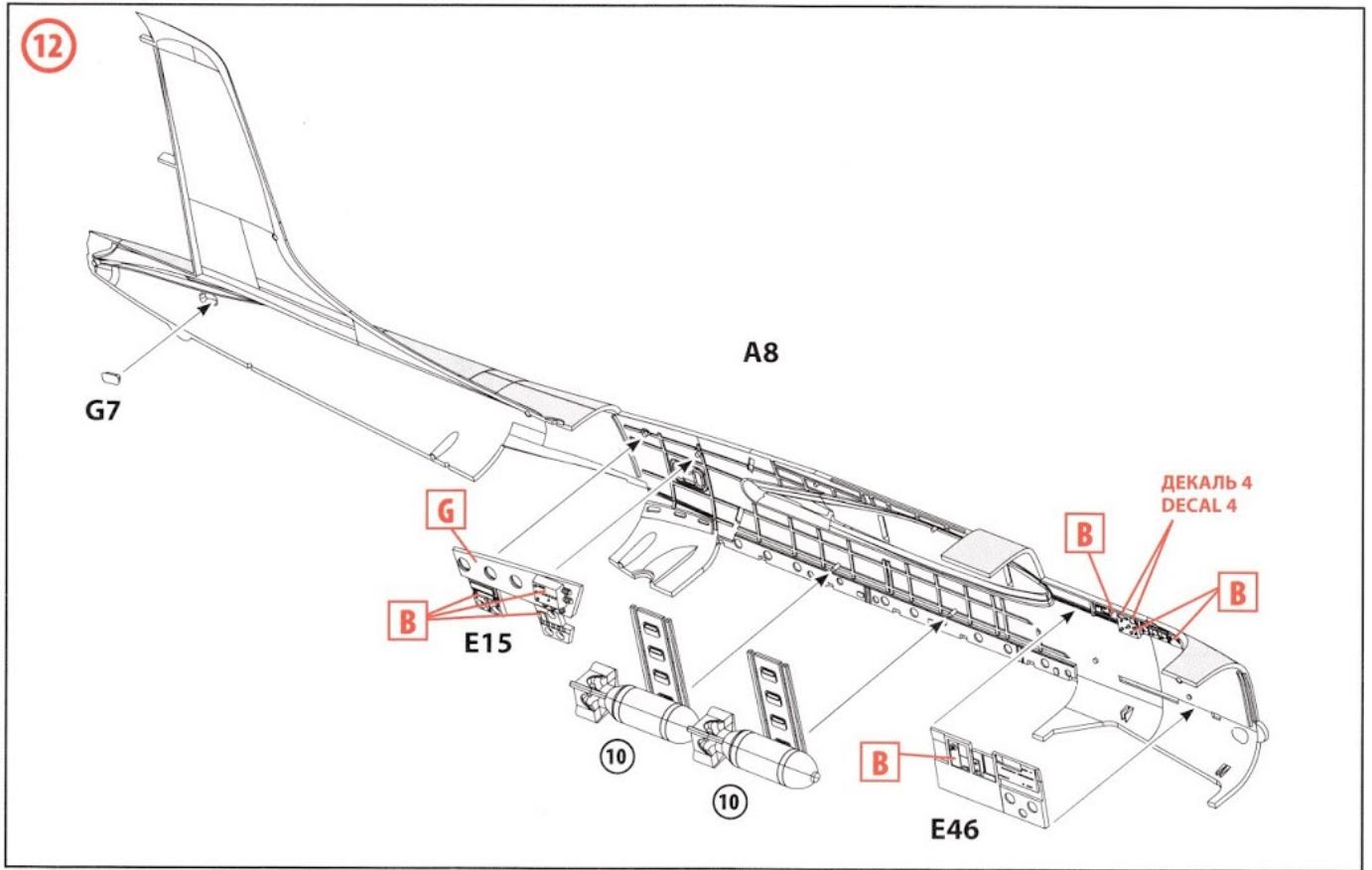

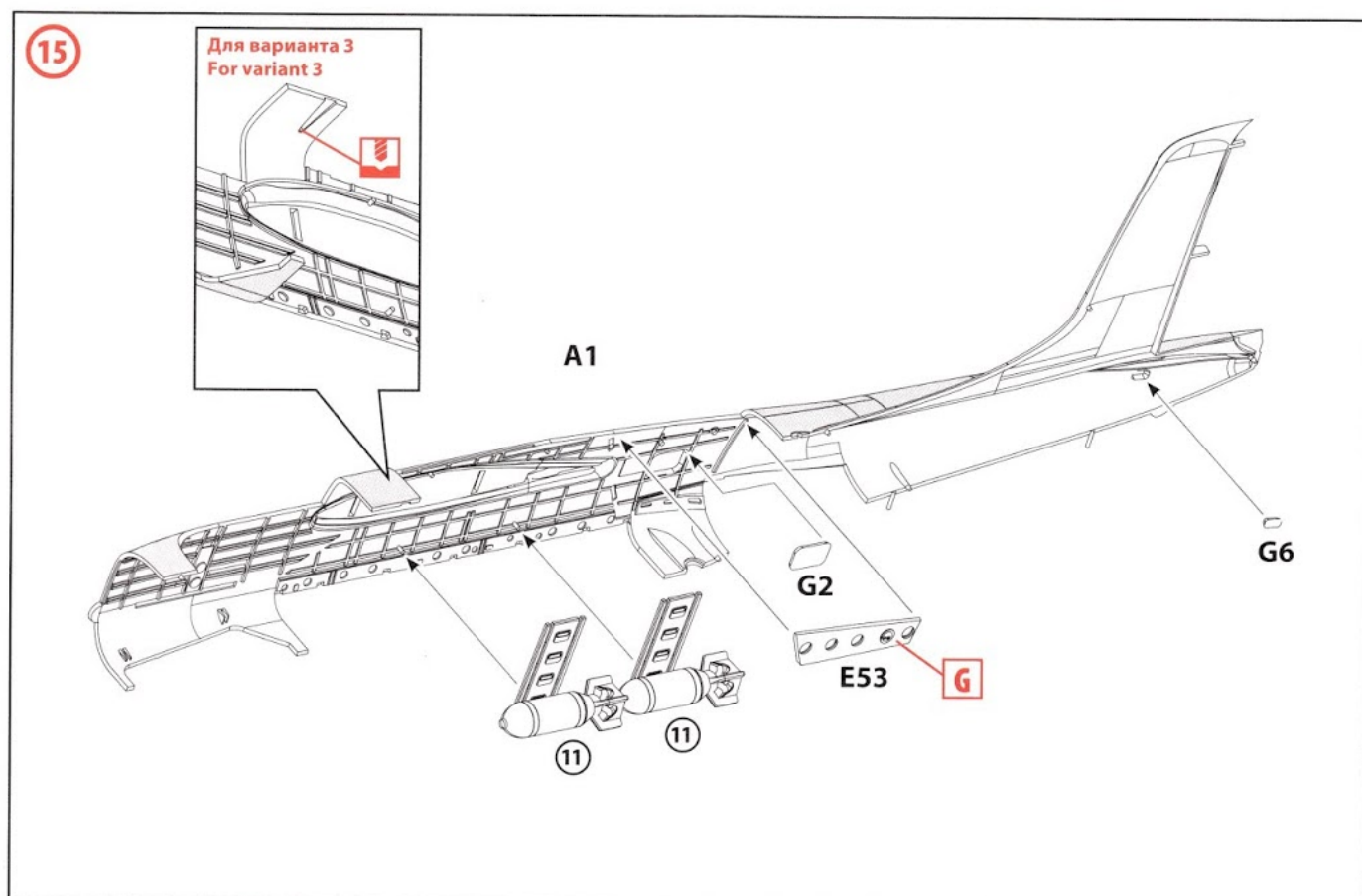
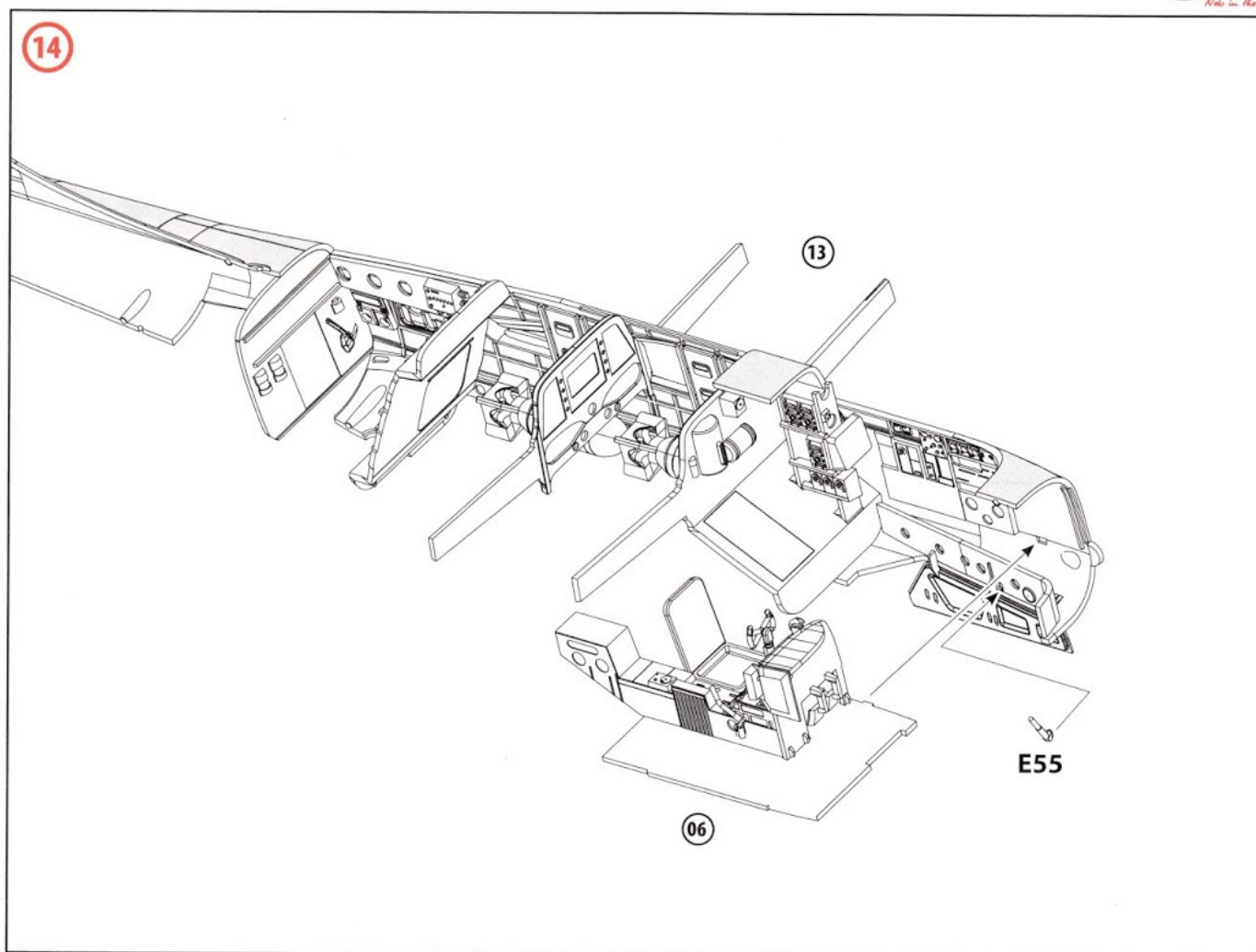

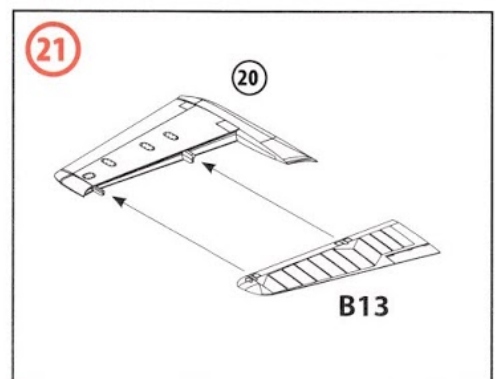
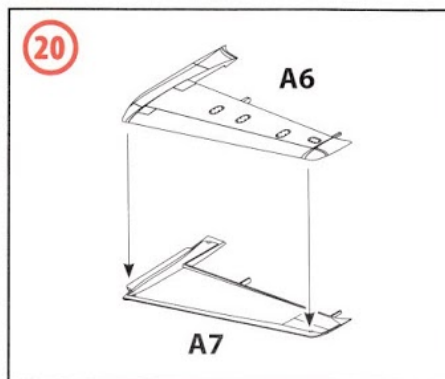
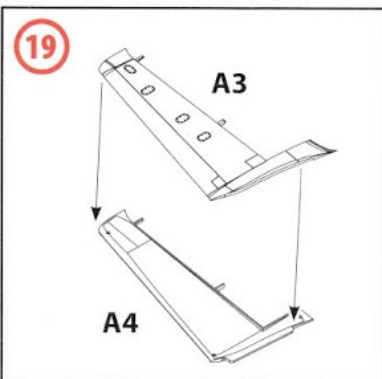
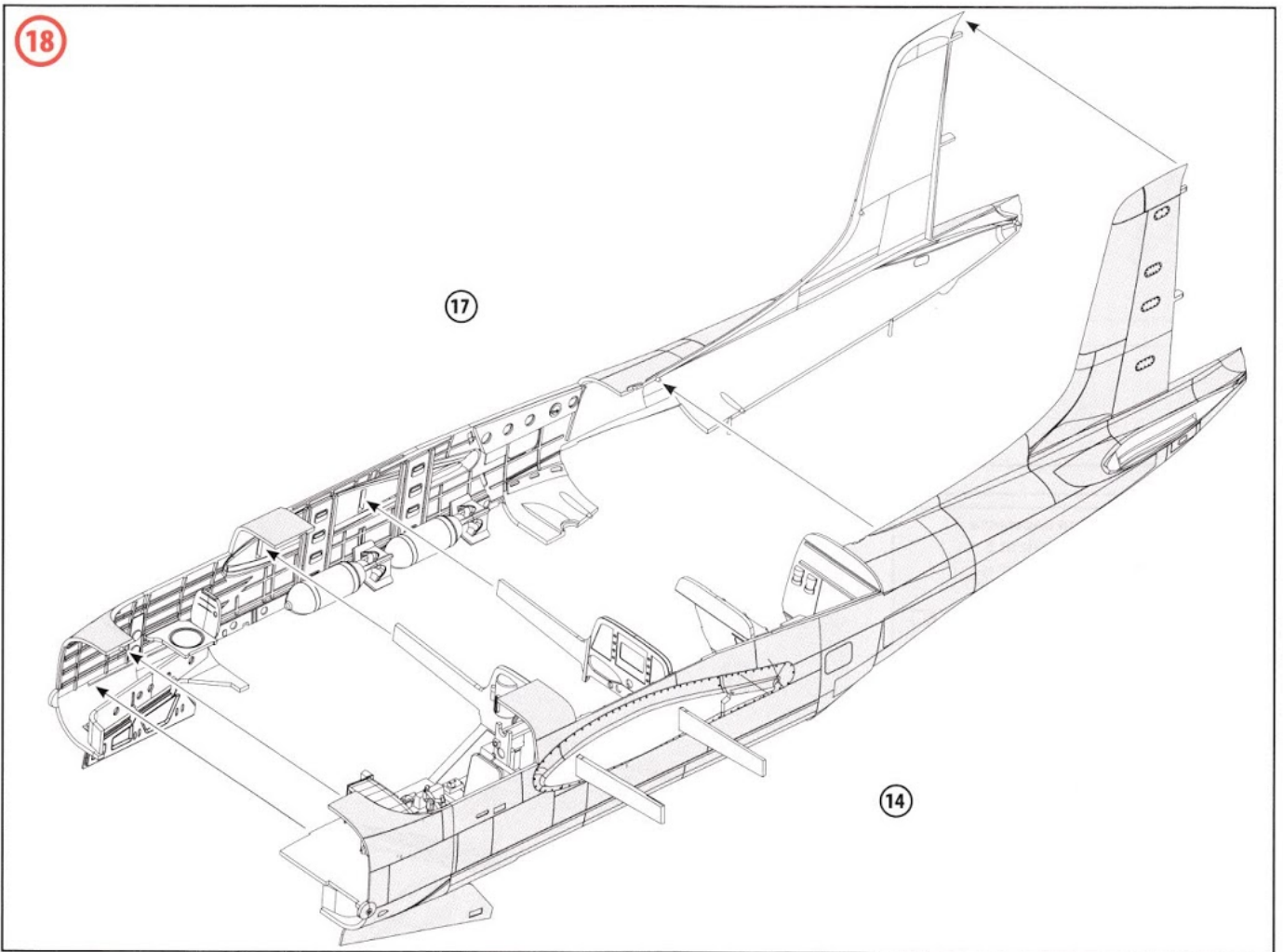
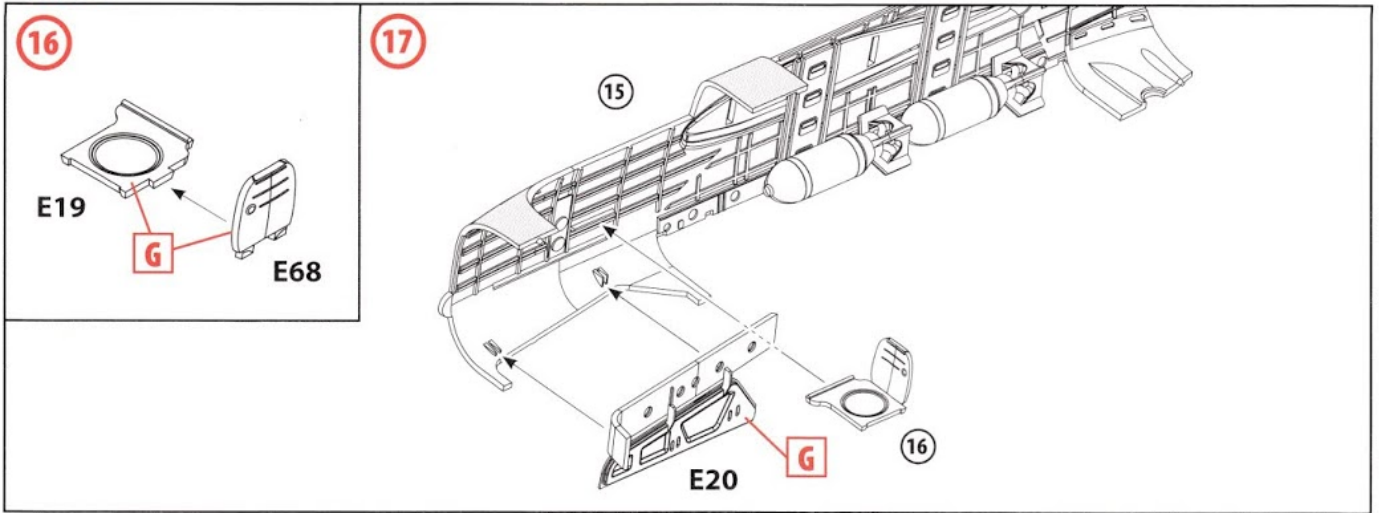

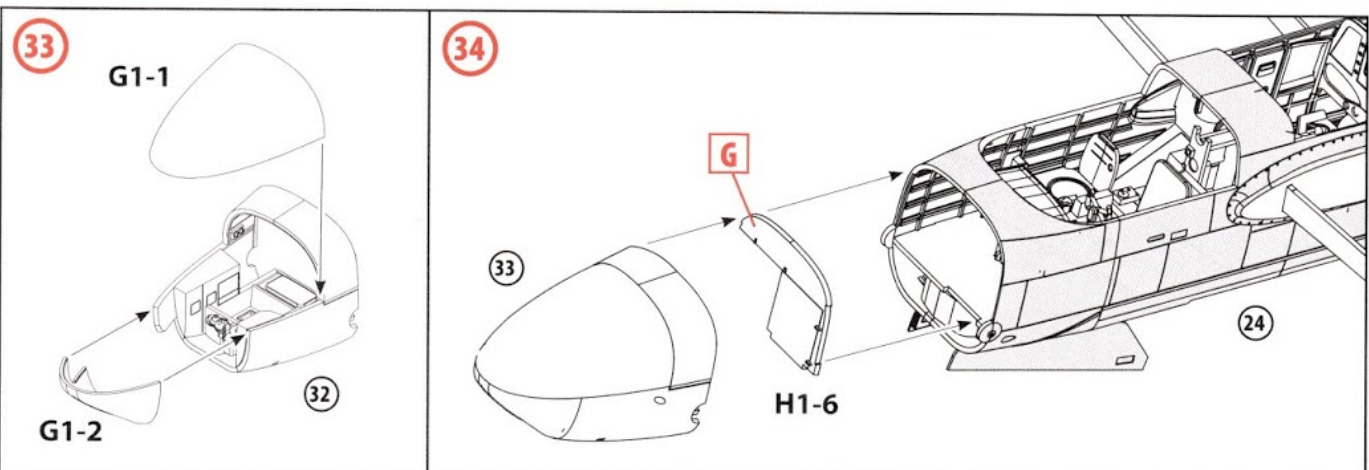
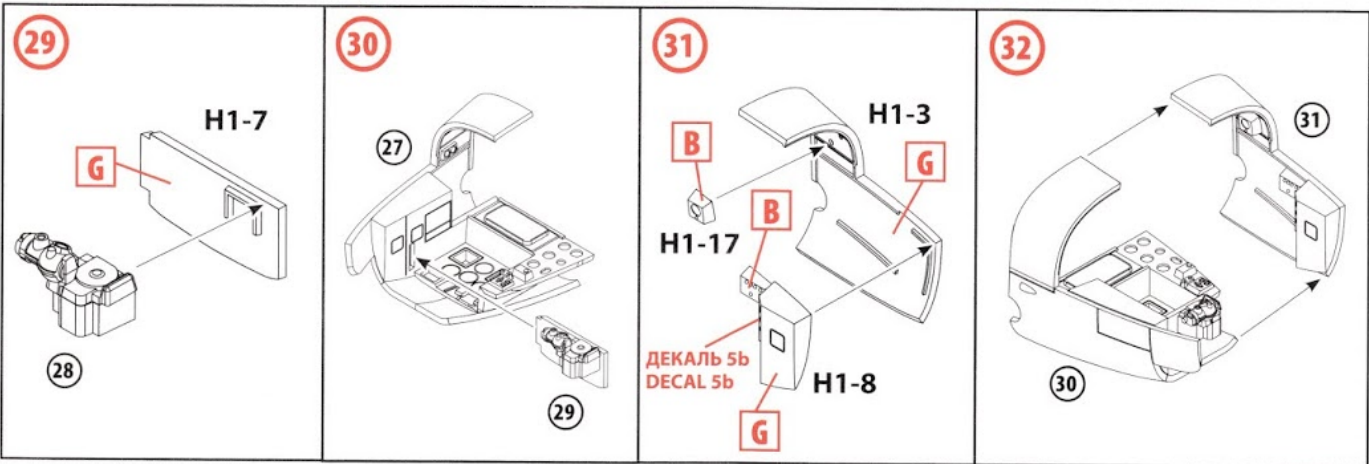
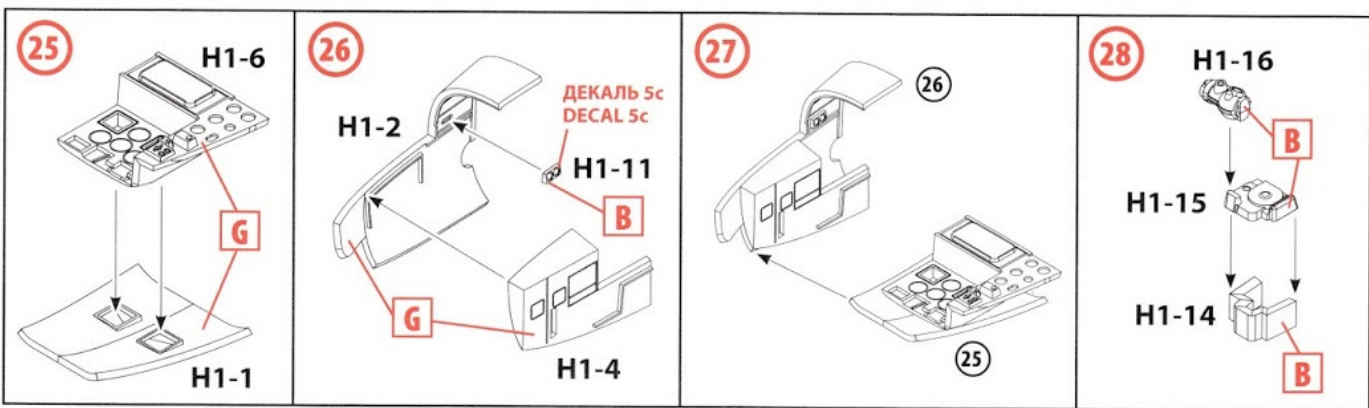
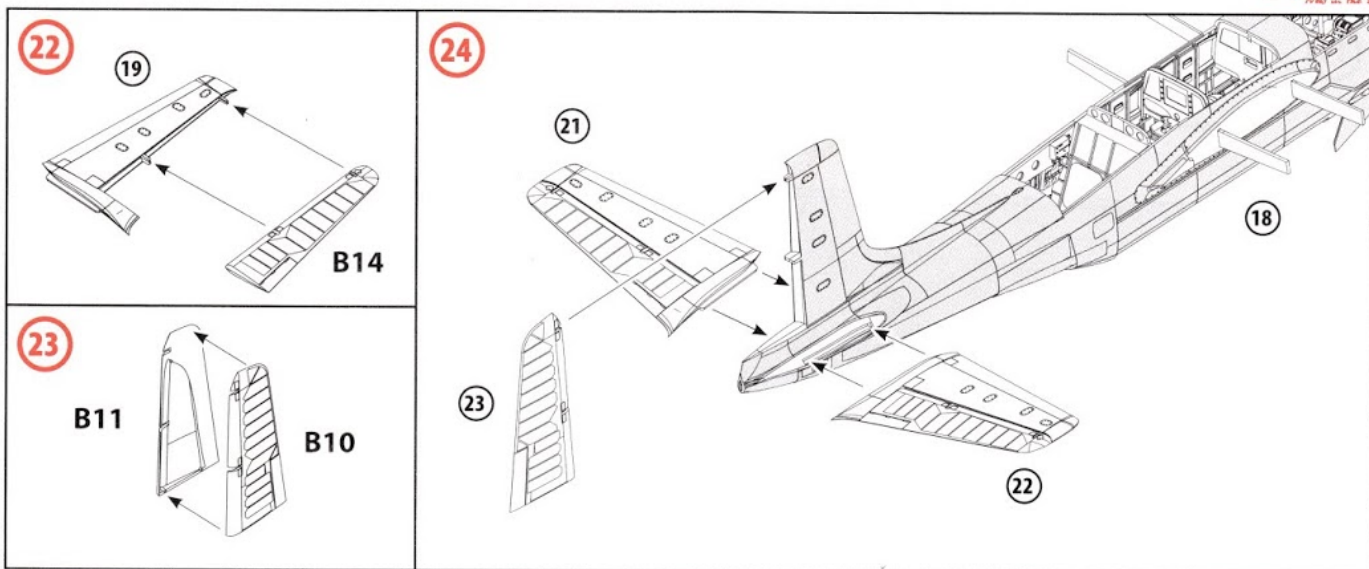

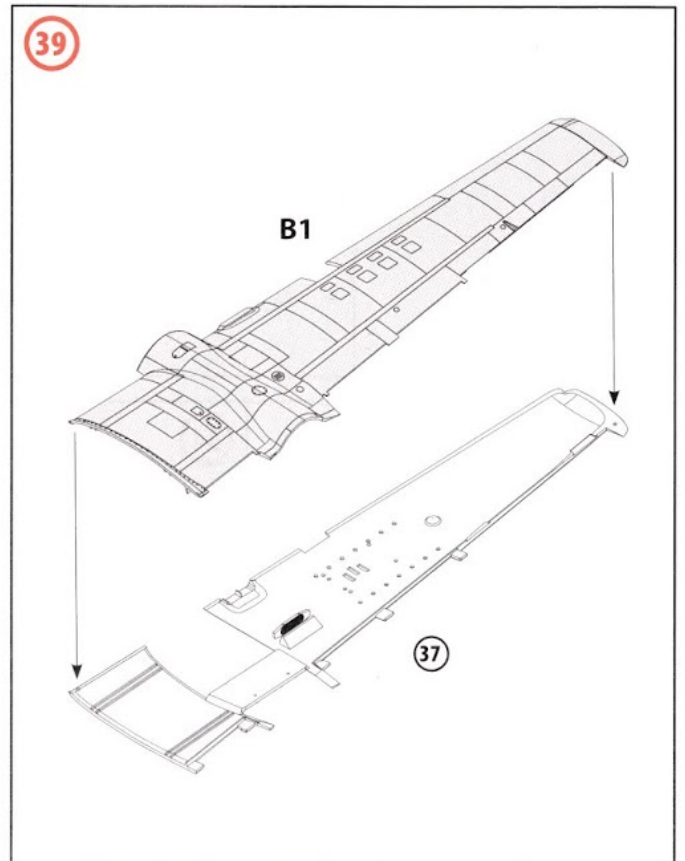
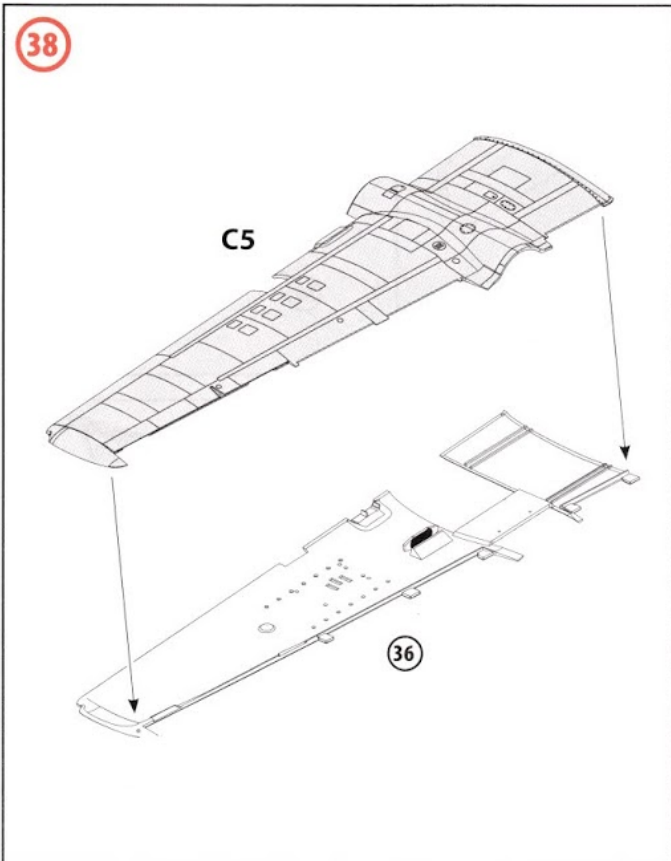
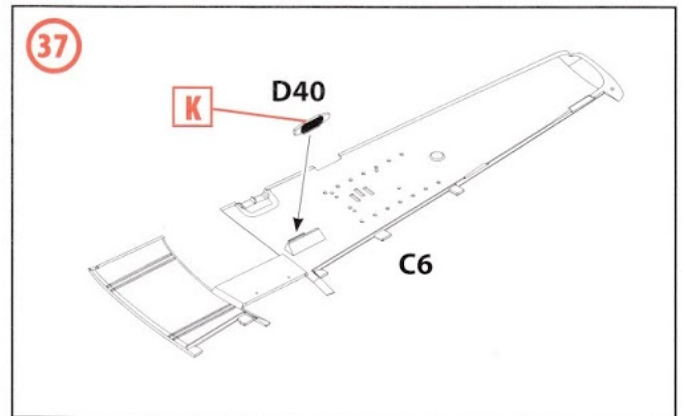
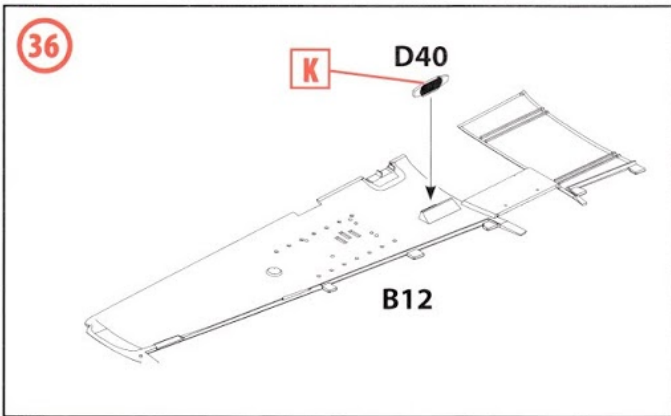
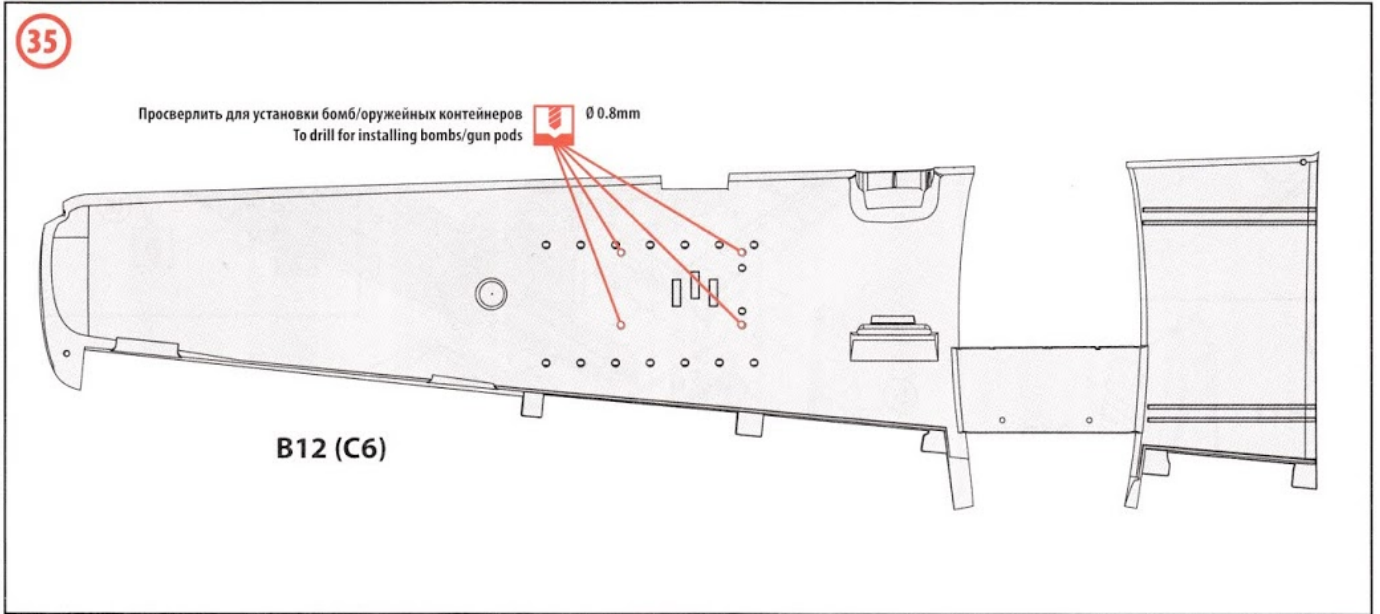

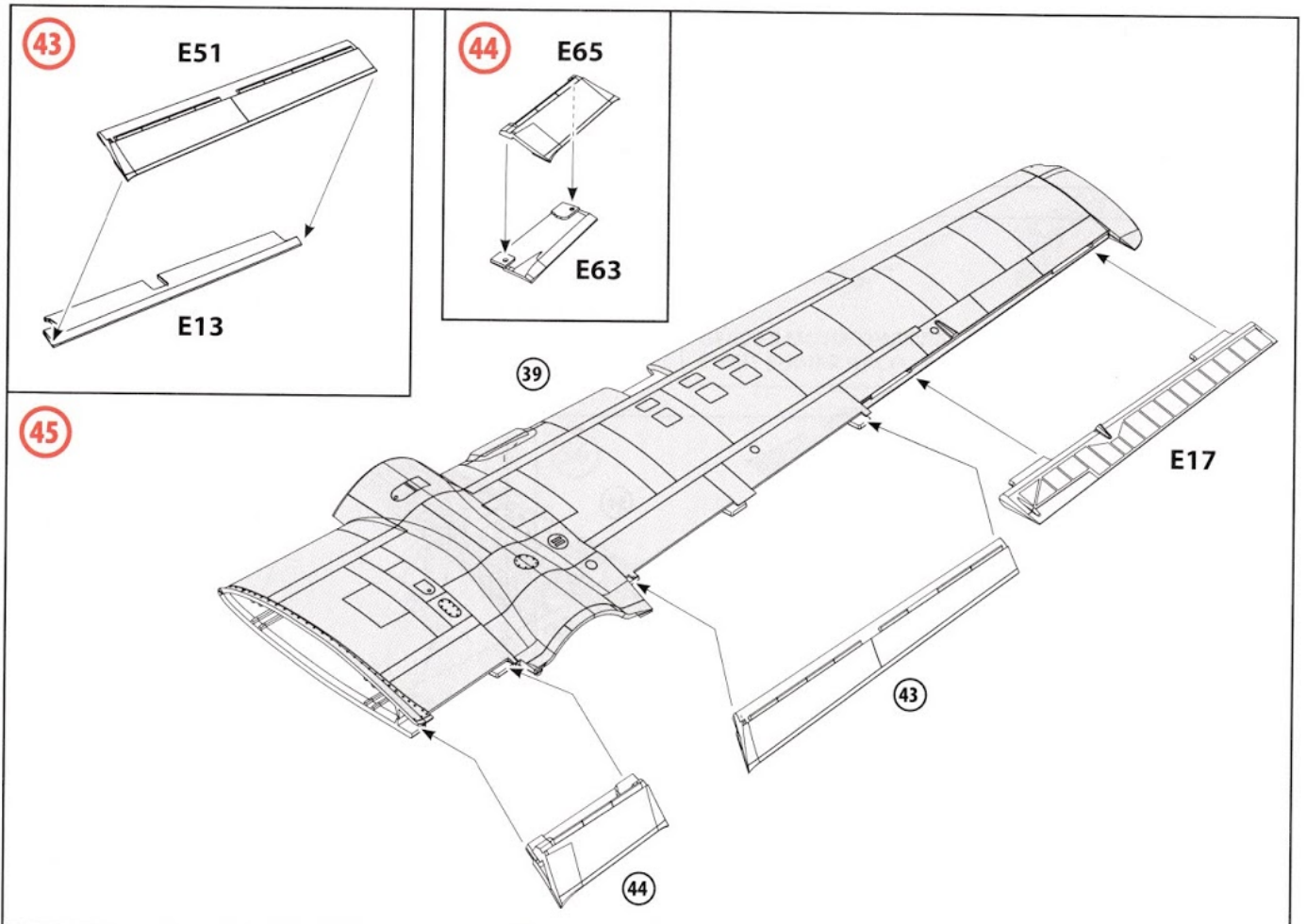
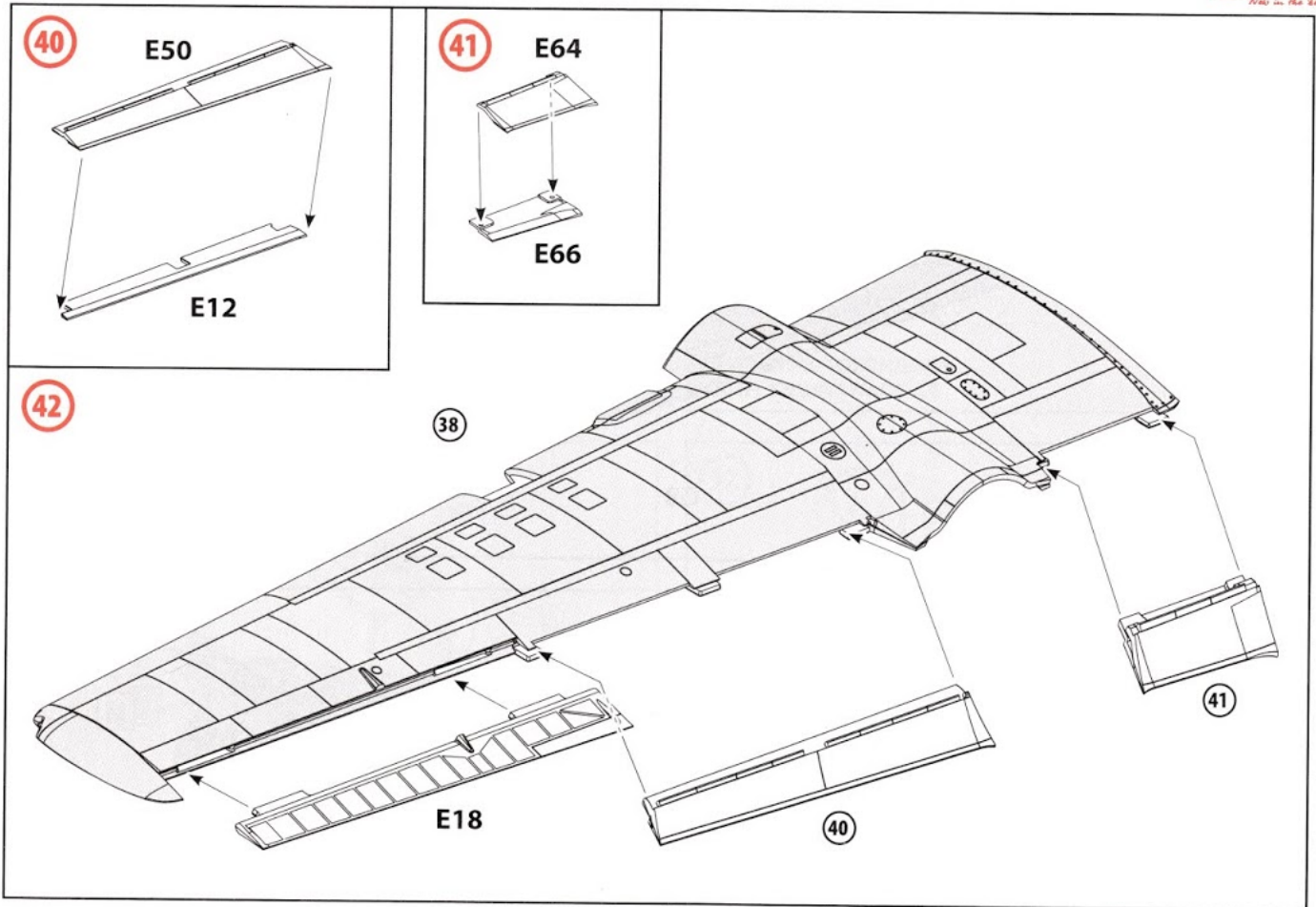

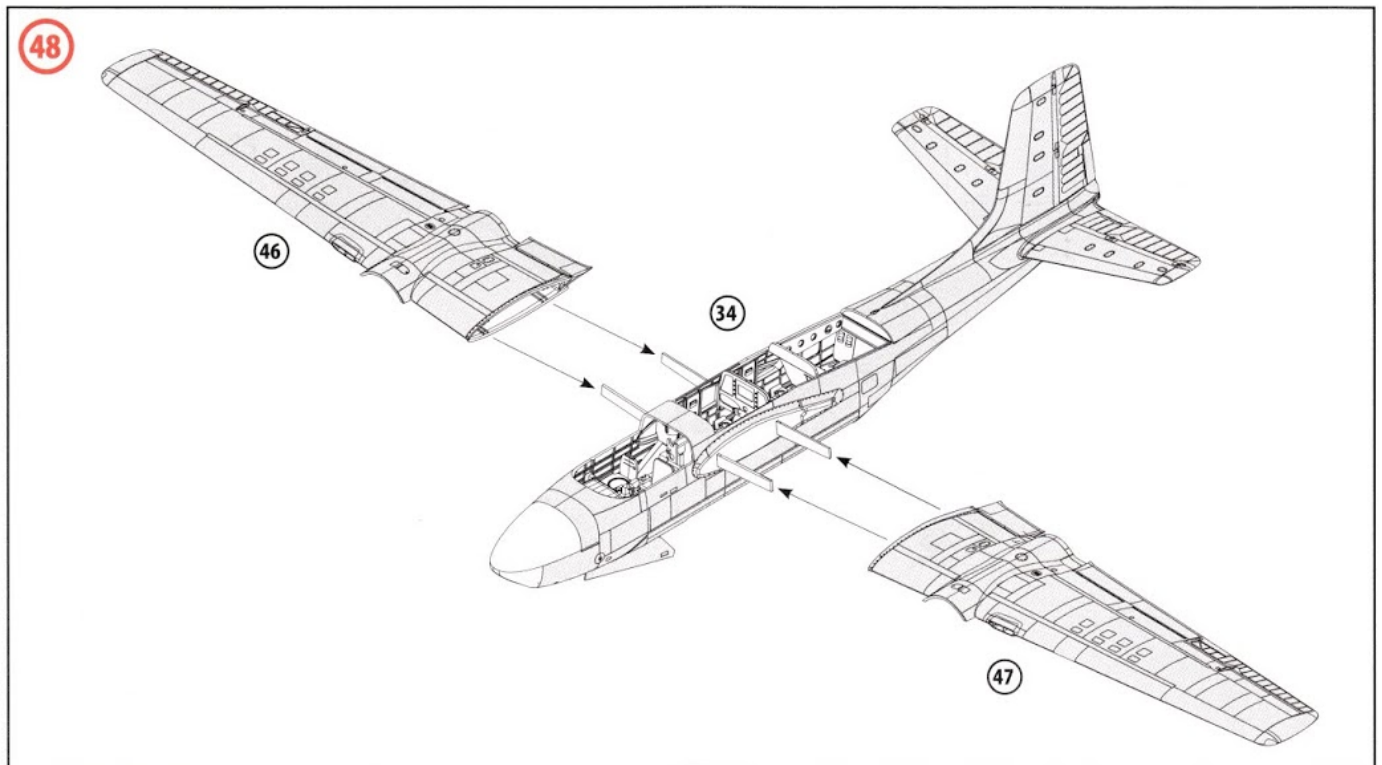
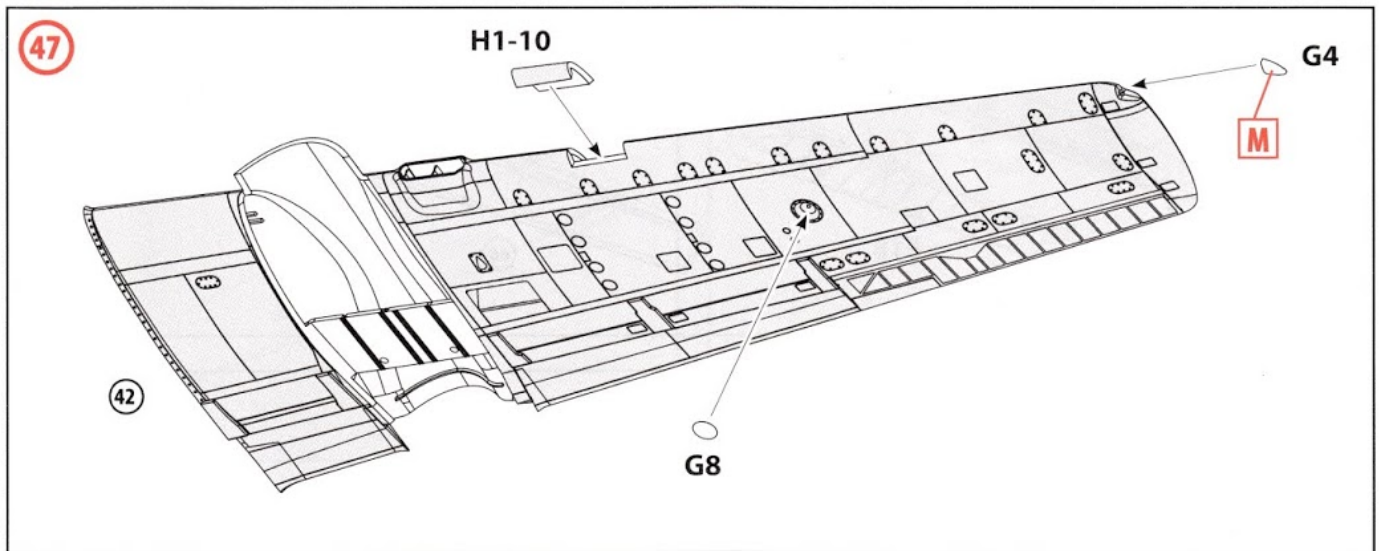
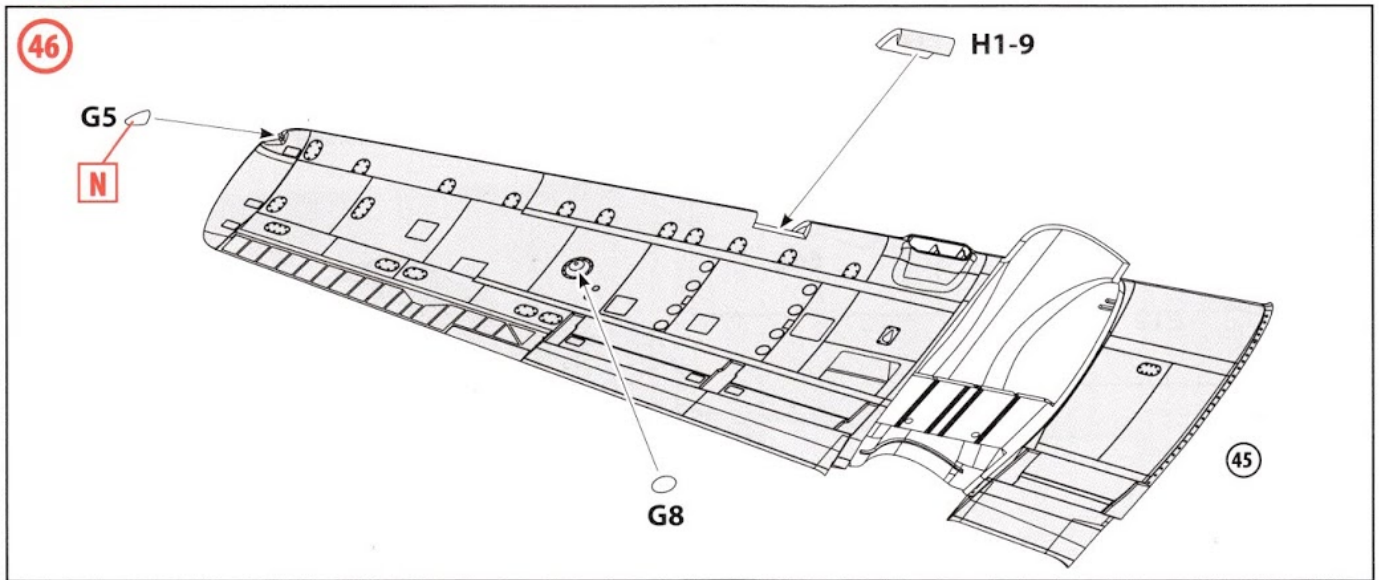

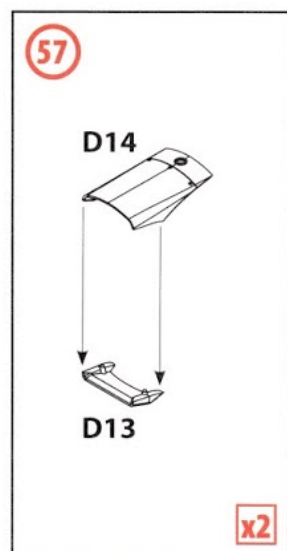
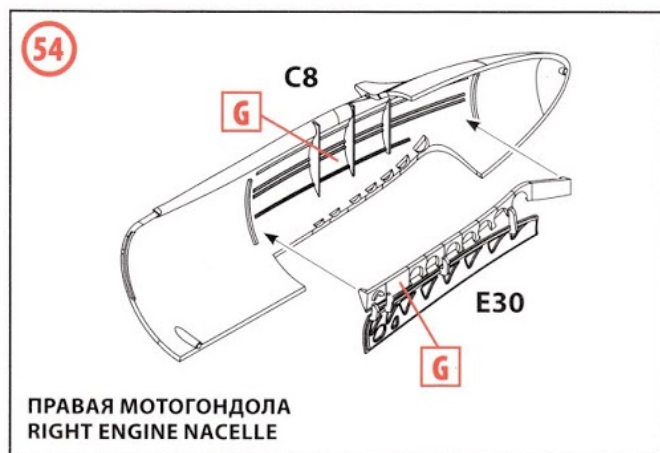
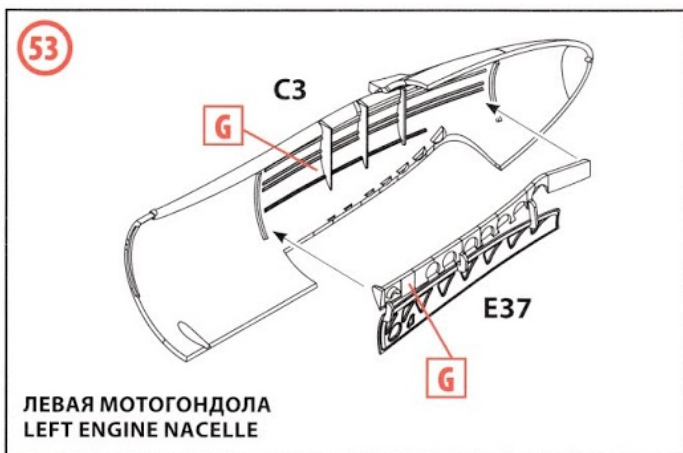
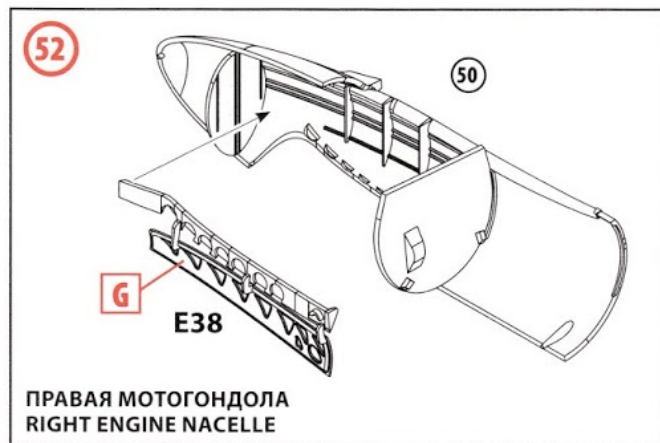
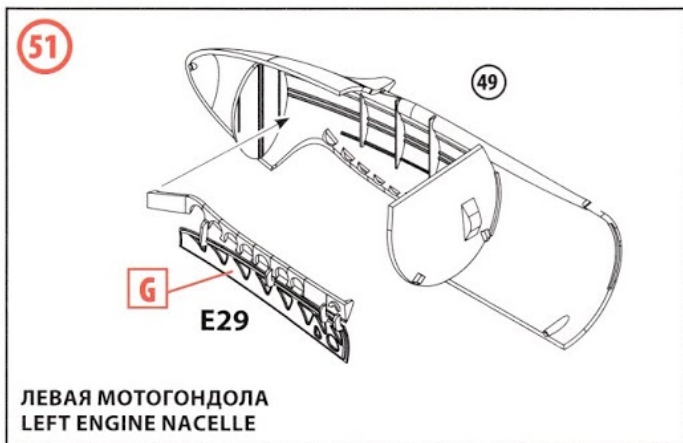
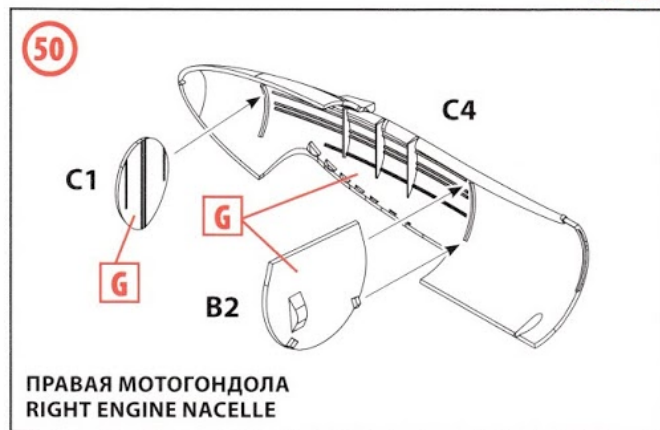
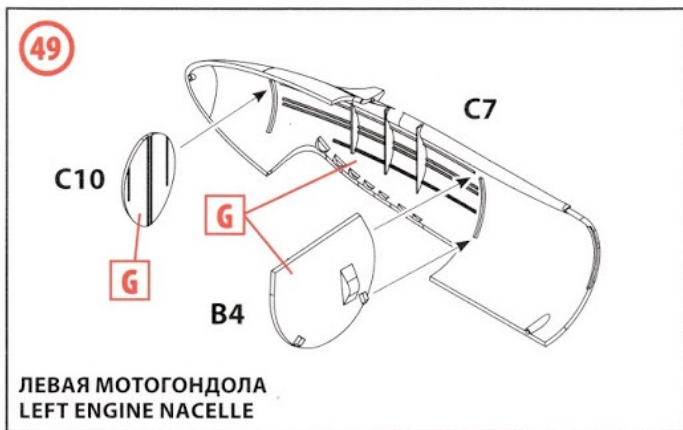

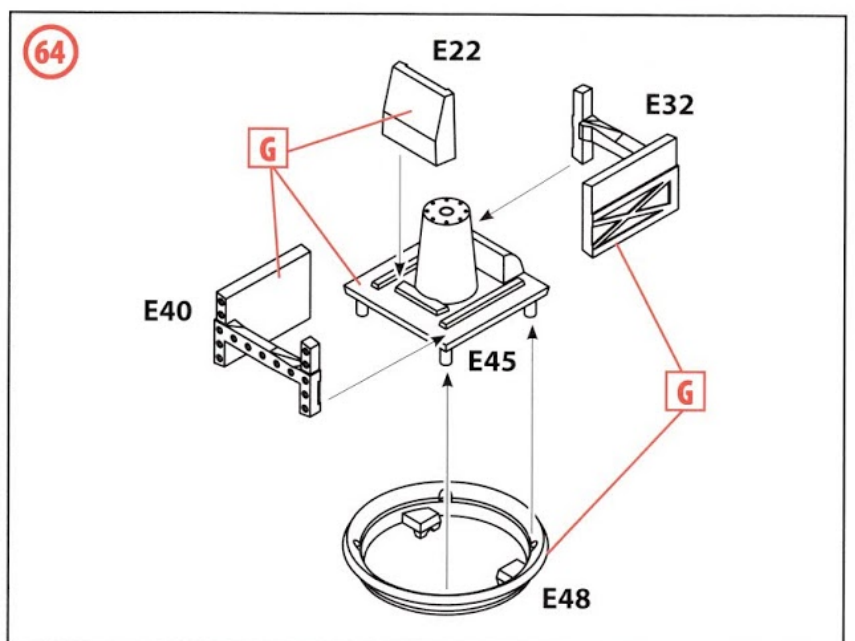
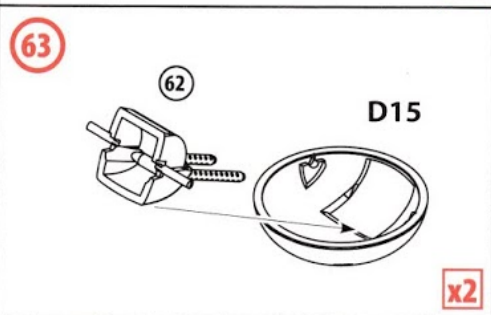
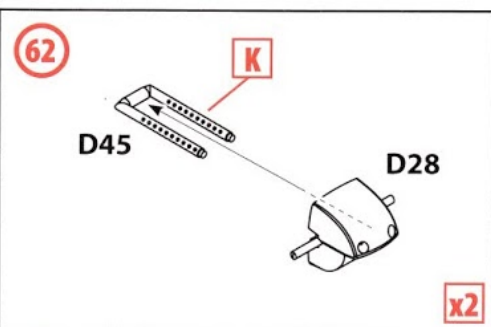
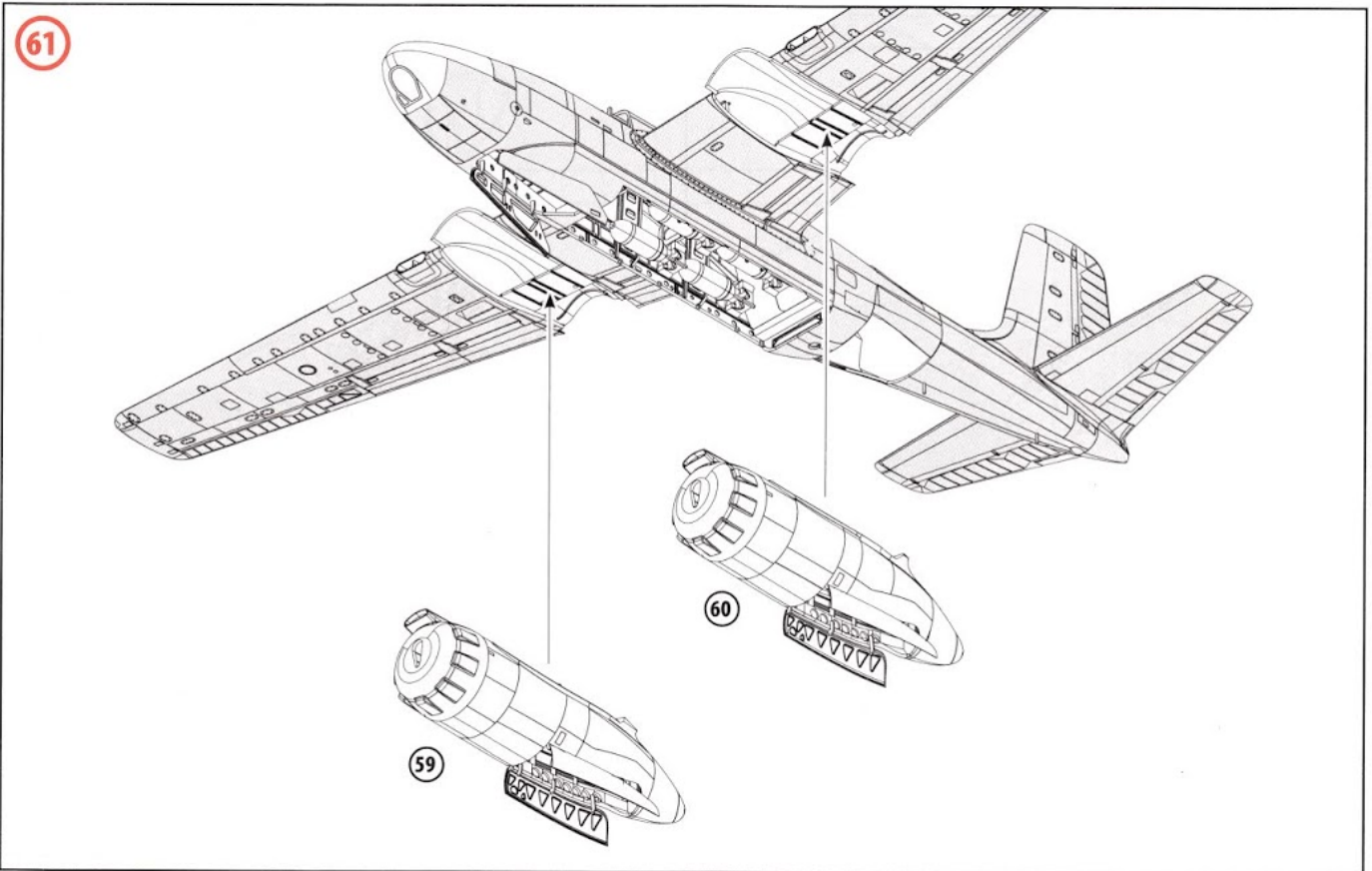
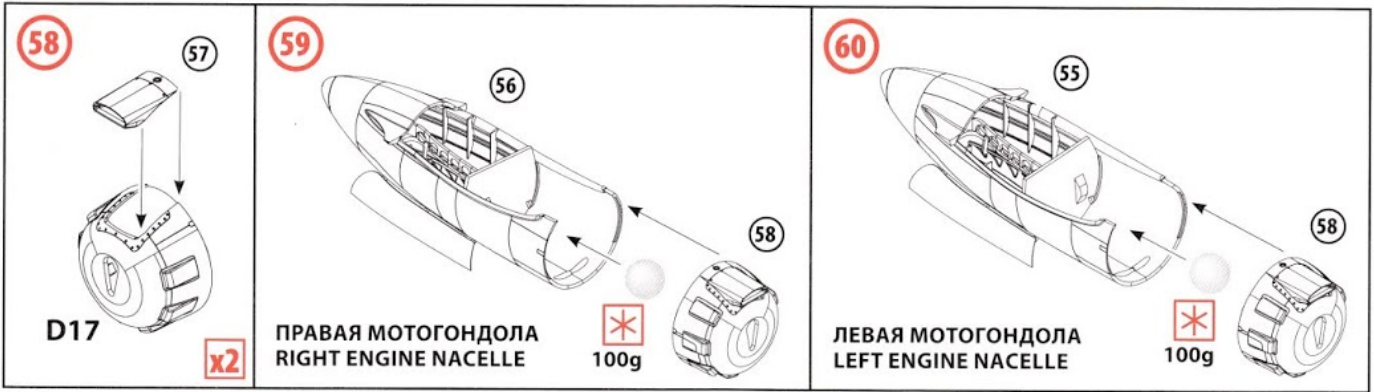

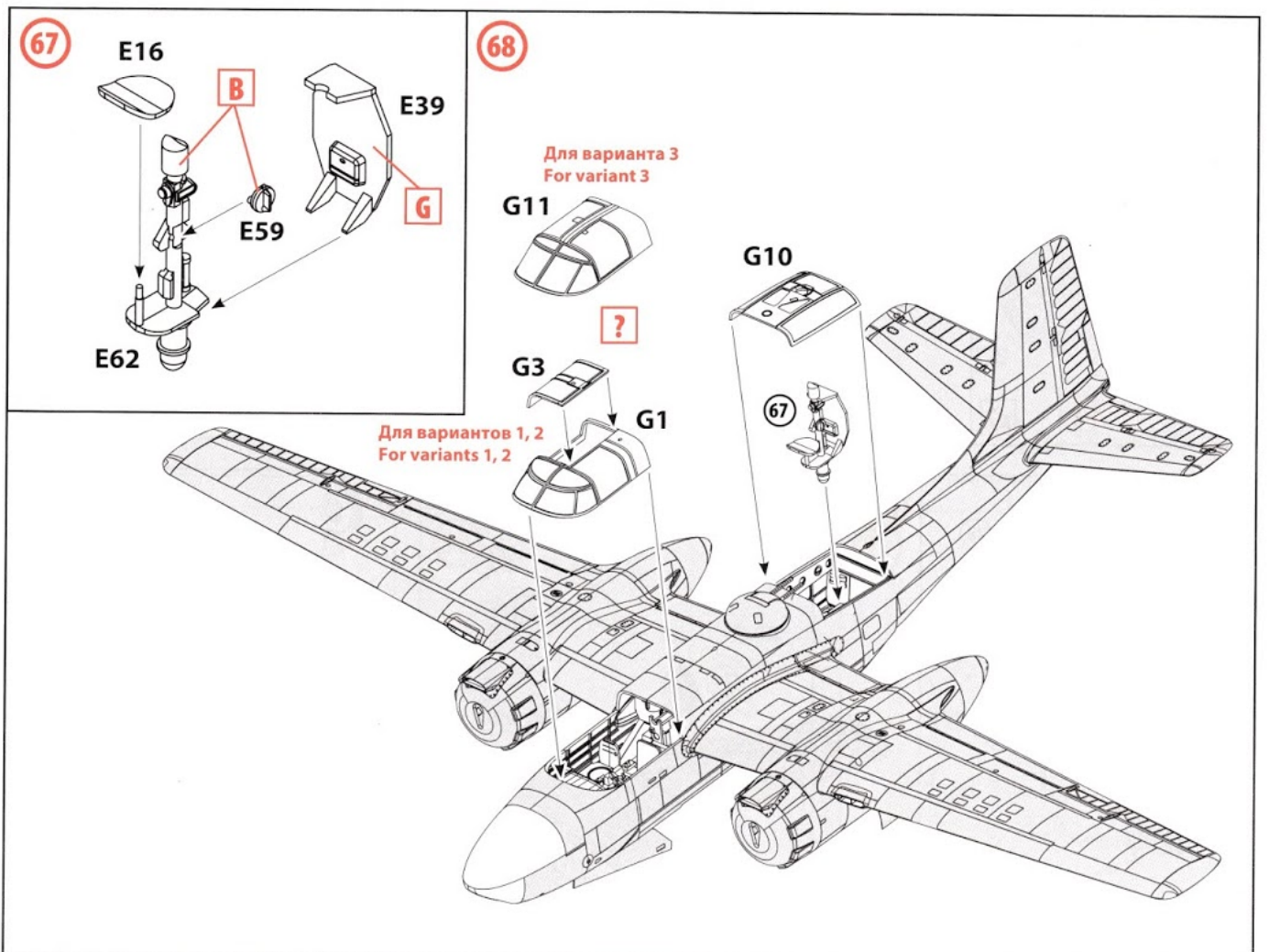
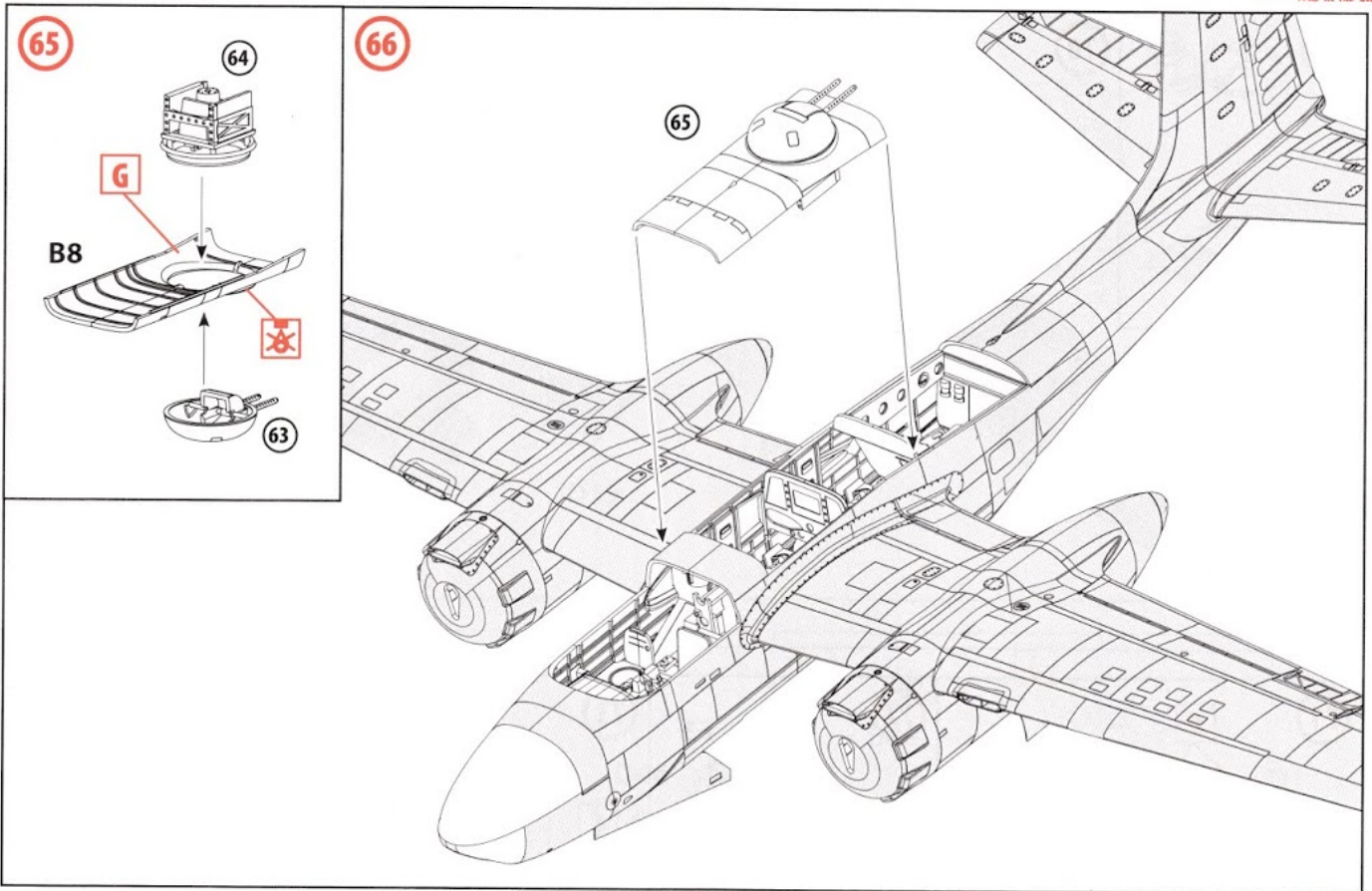

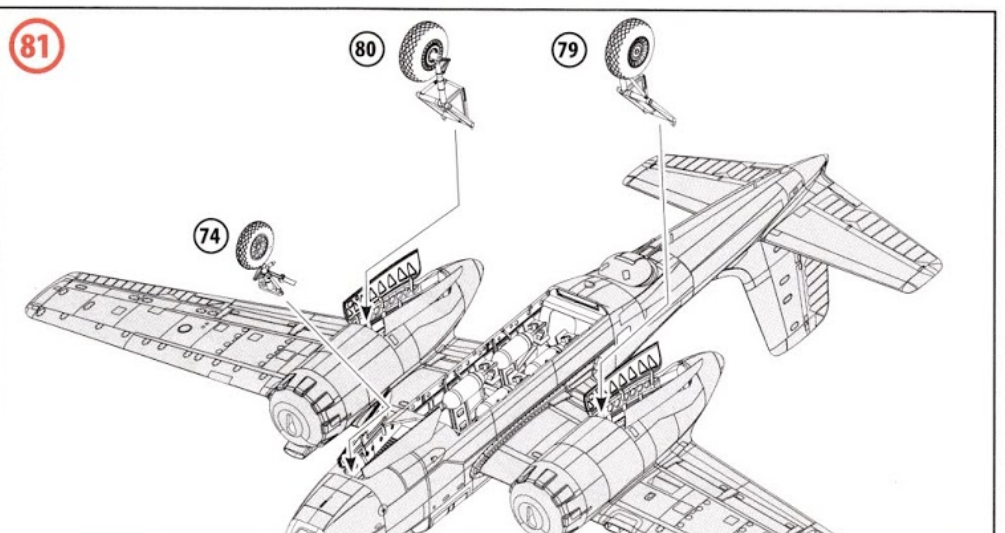
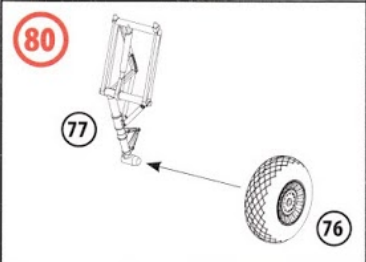
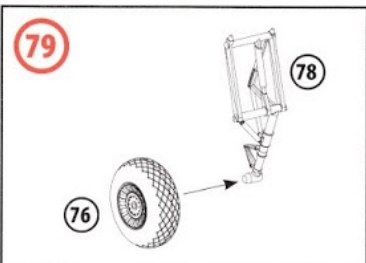
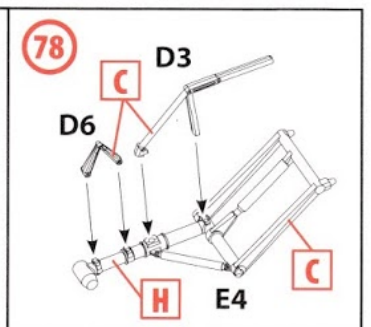
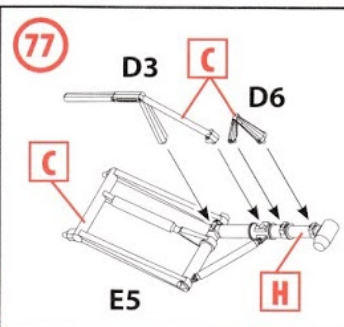
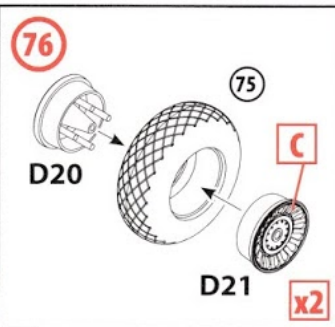
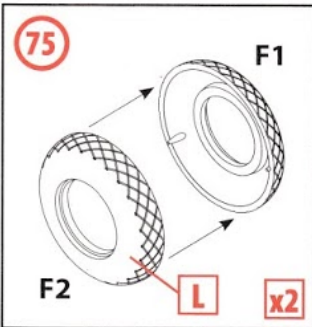
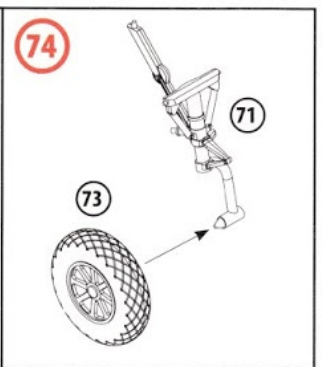
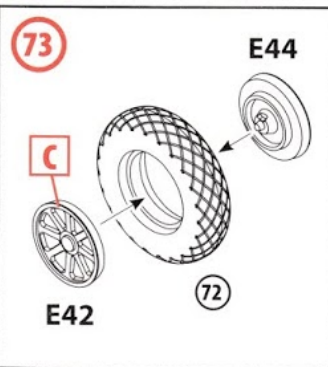
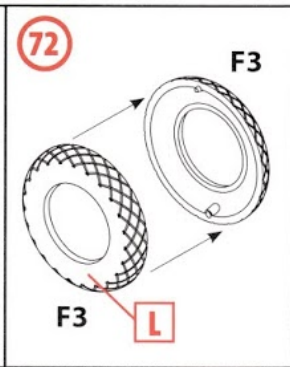
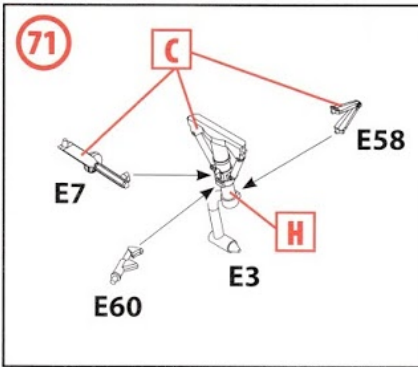
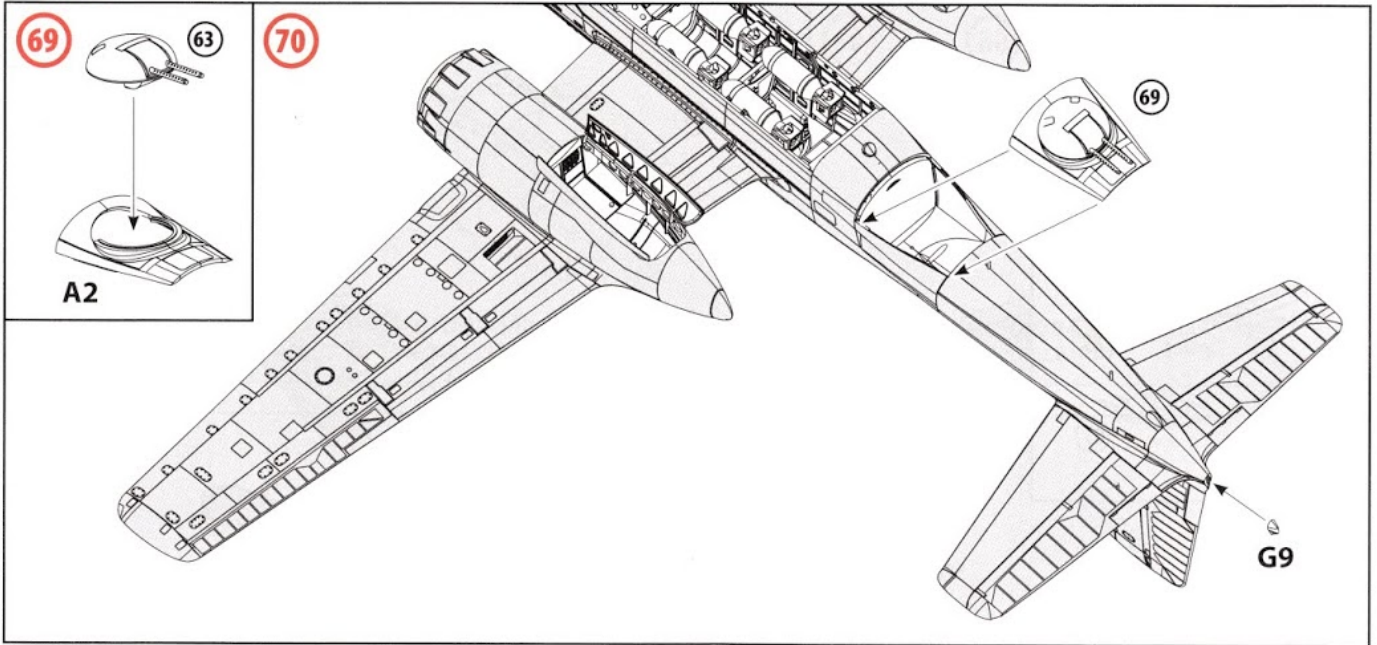

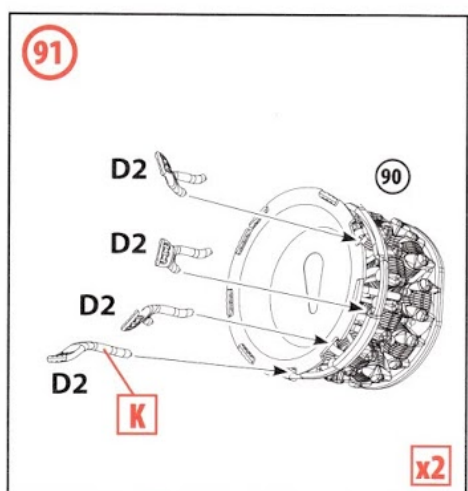
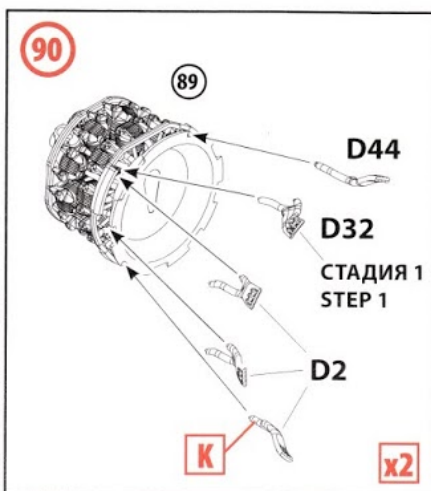
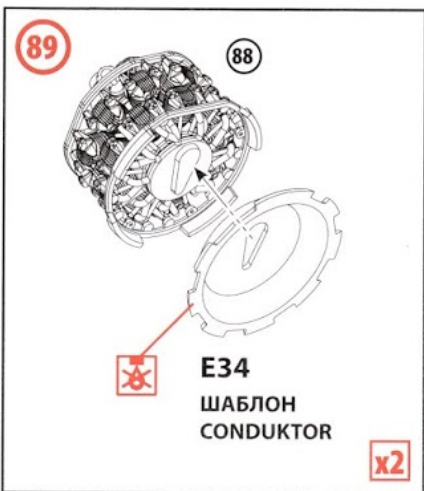
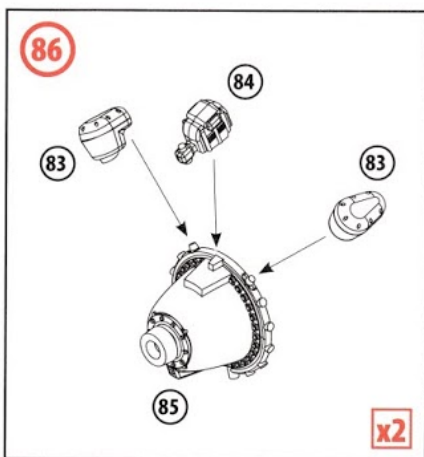
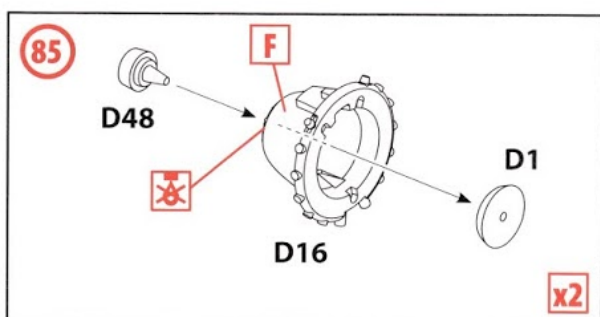
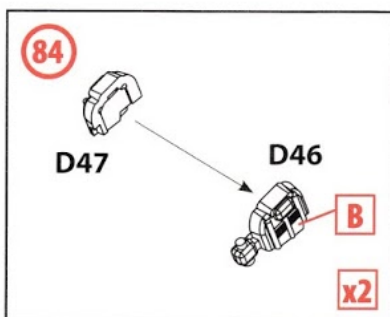
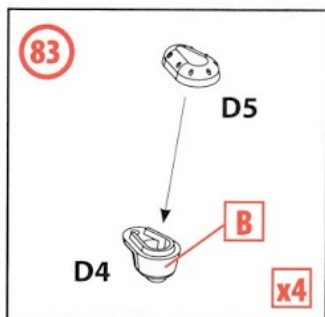
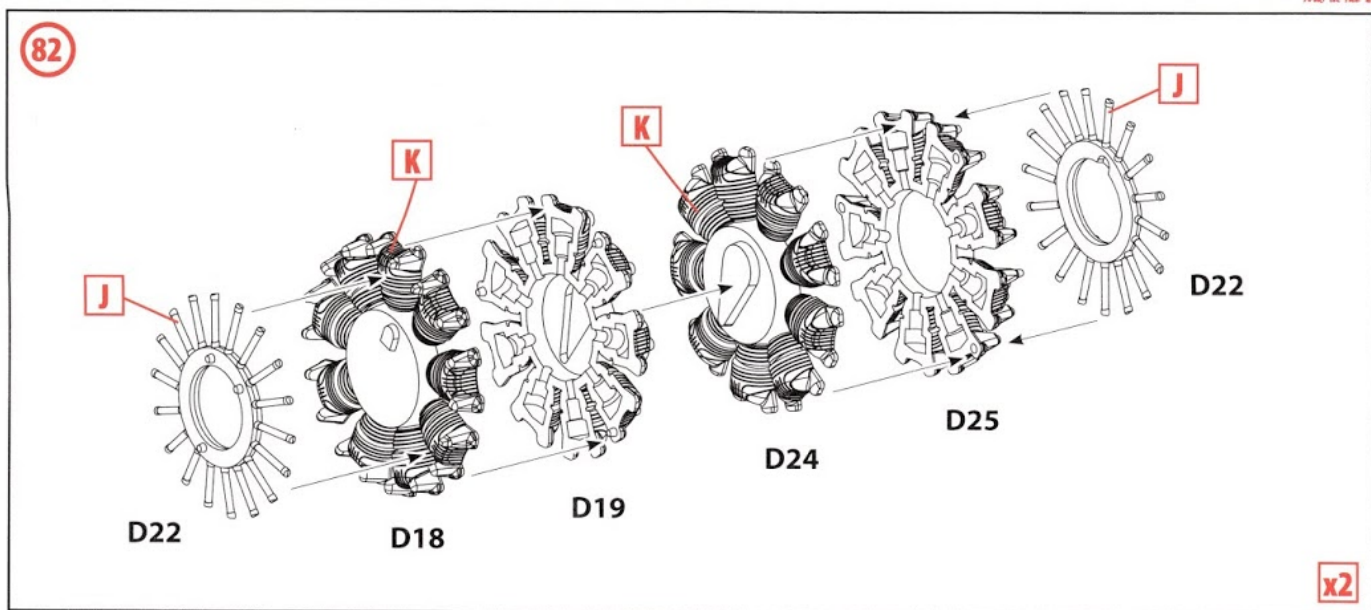

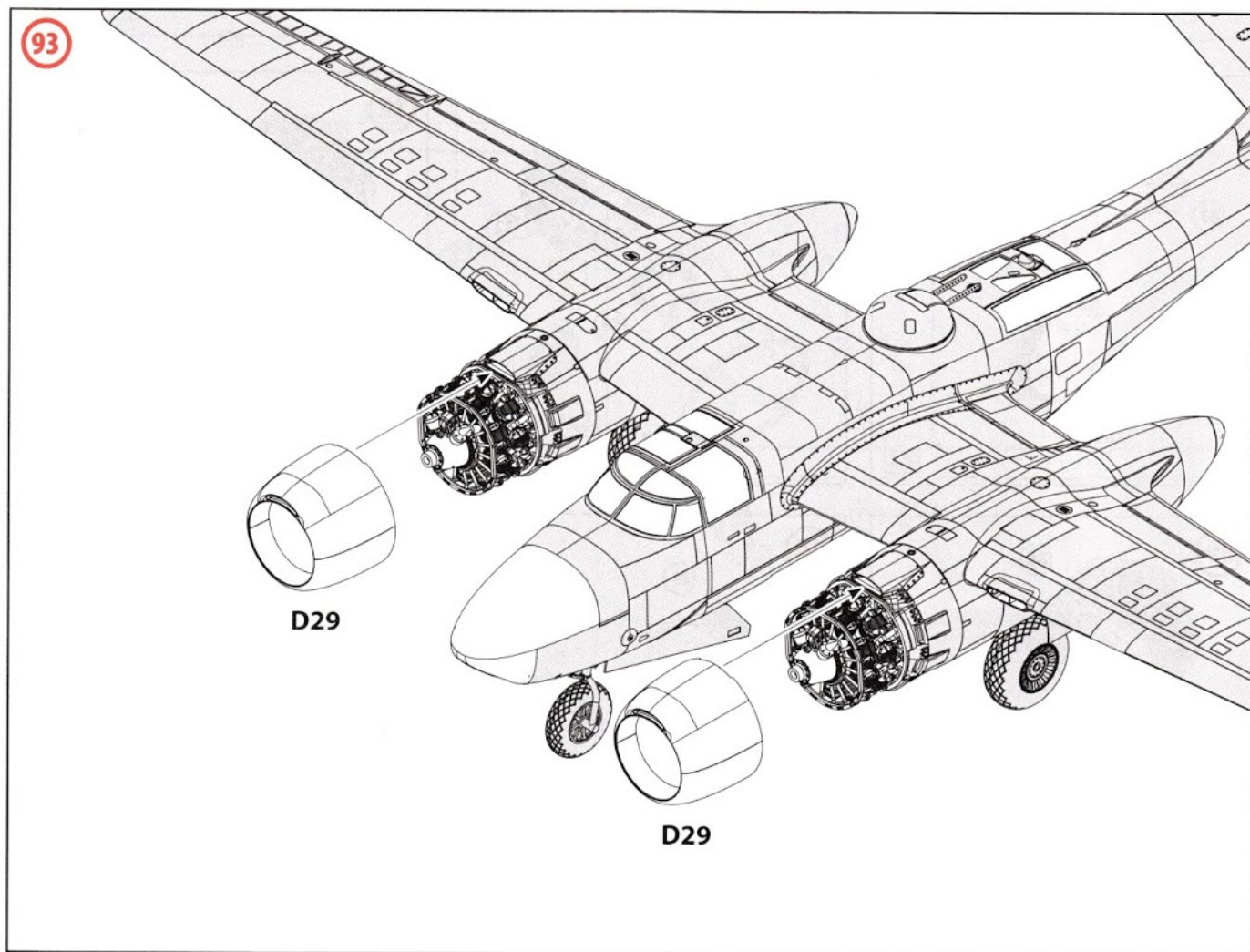
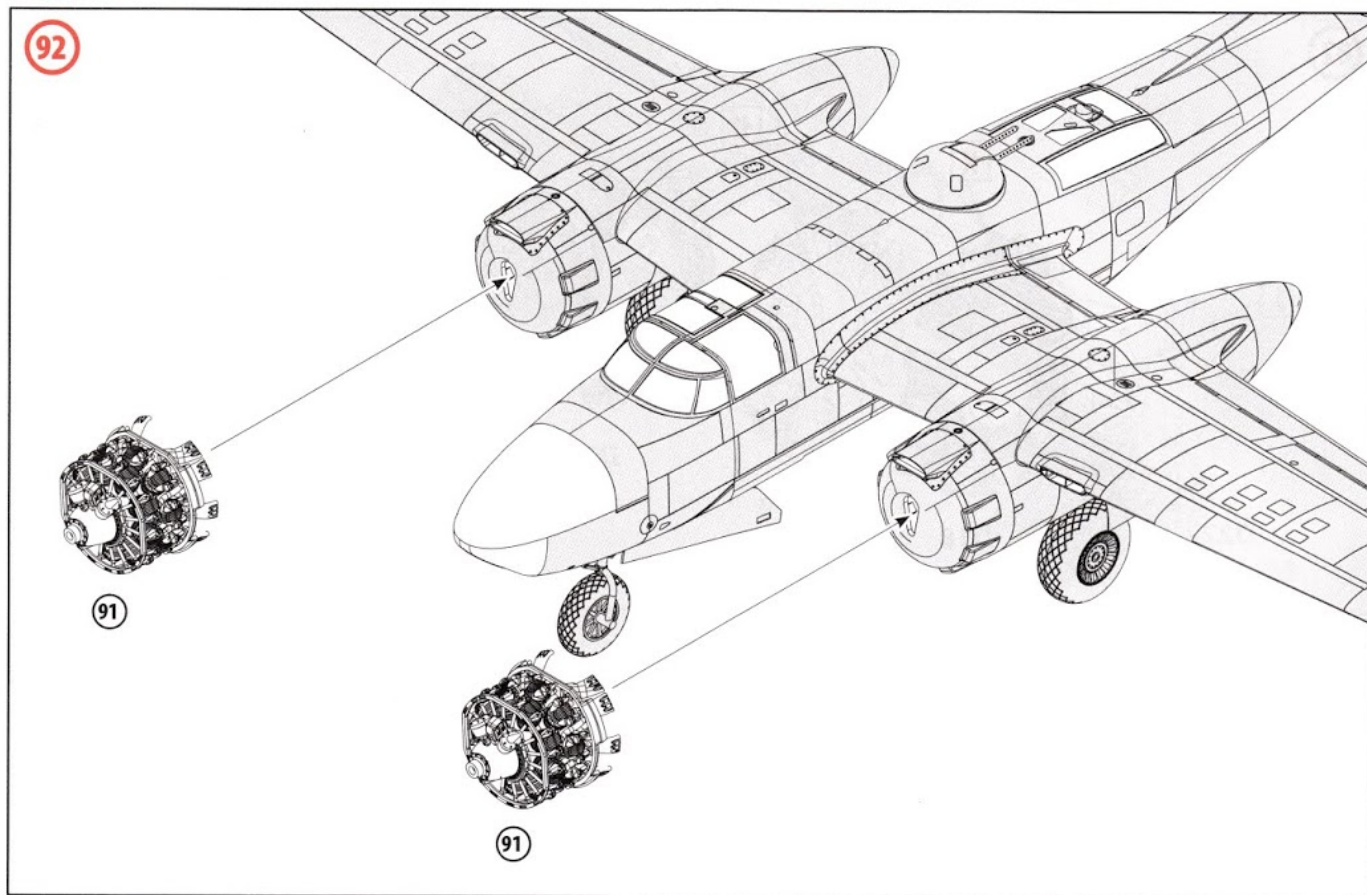

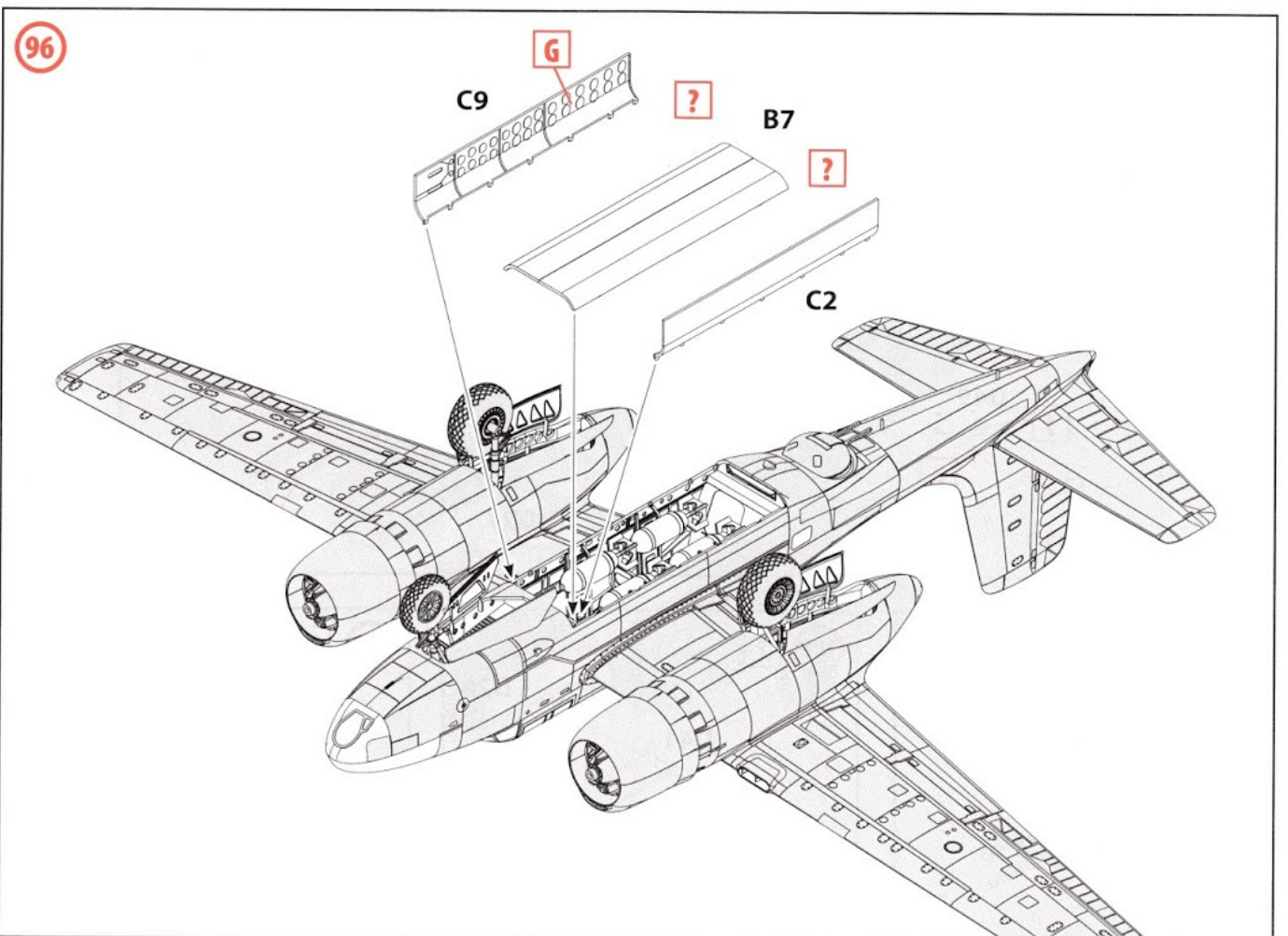
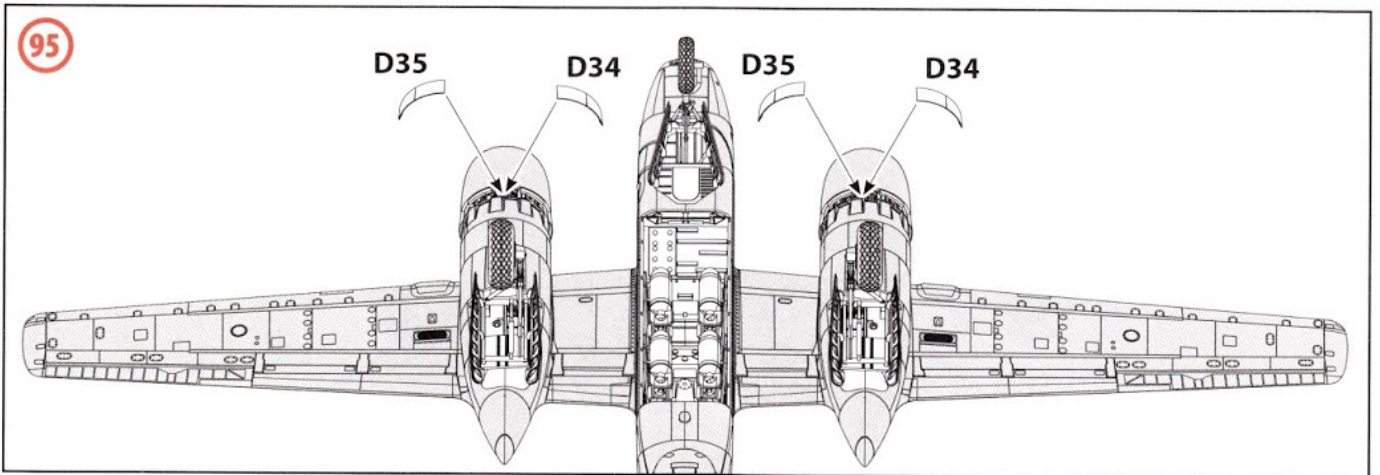
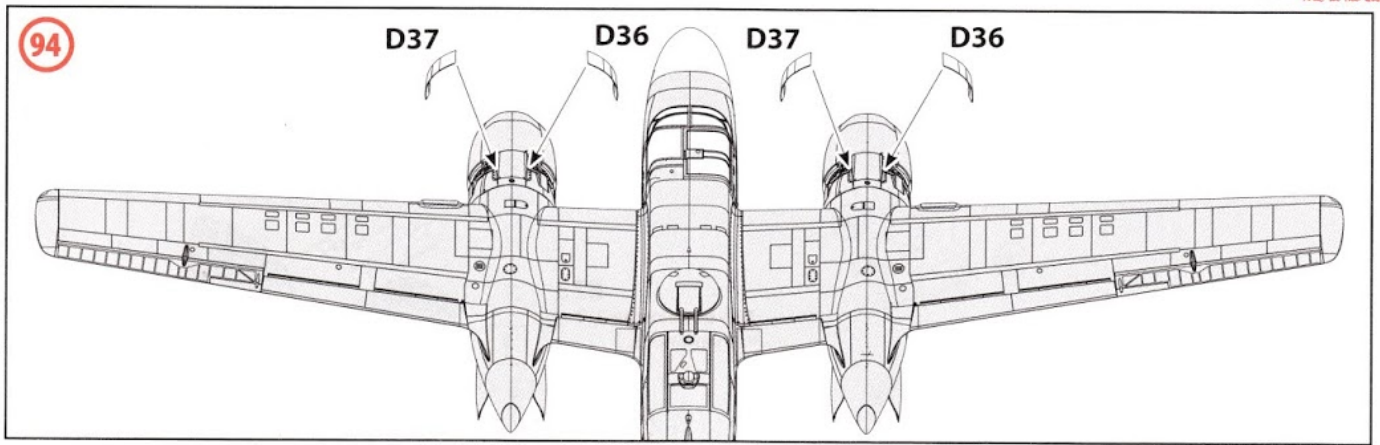

97

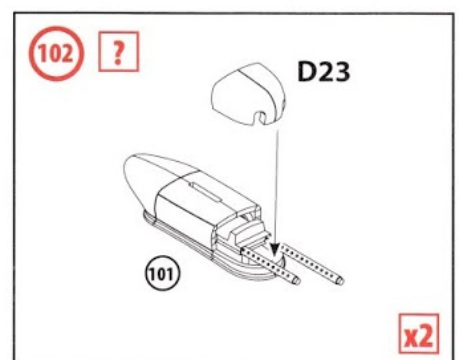
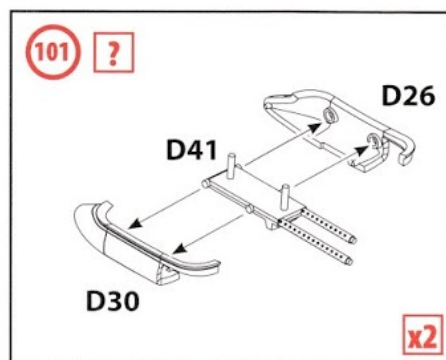
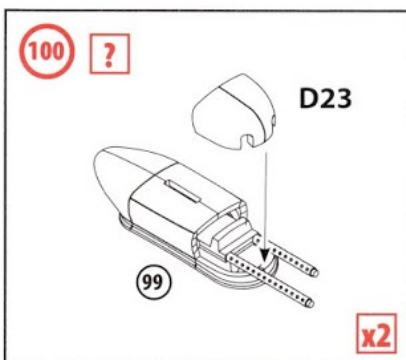
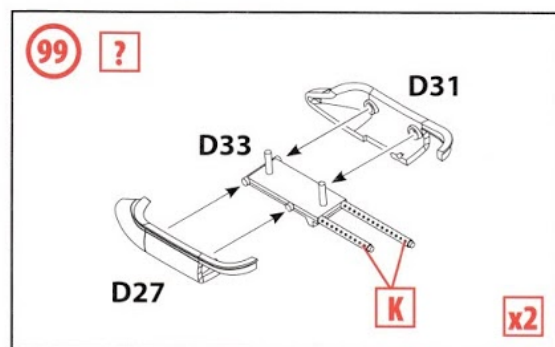
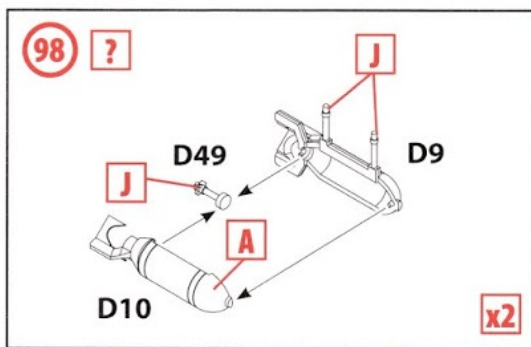
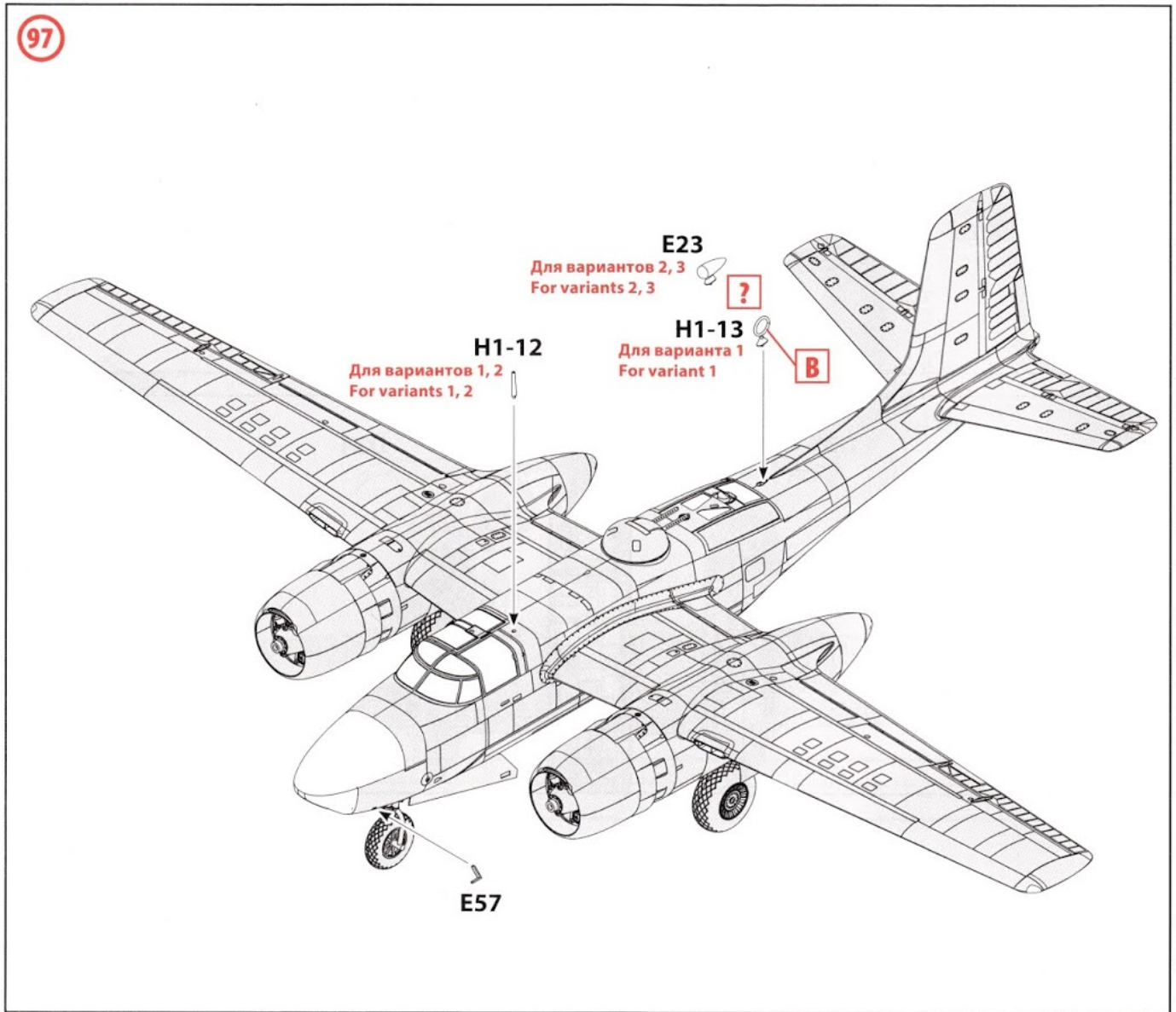

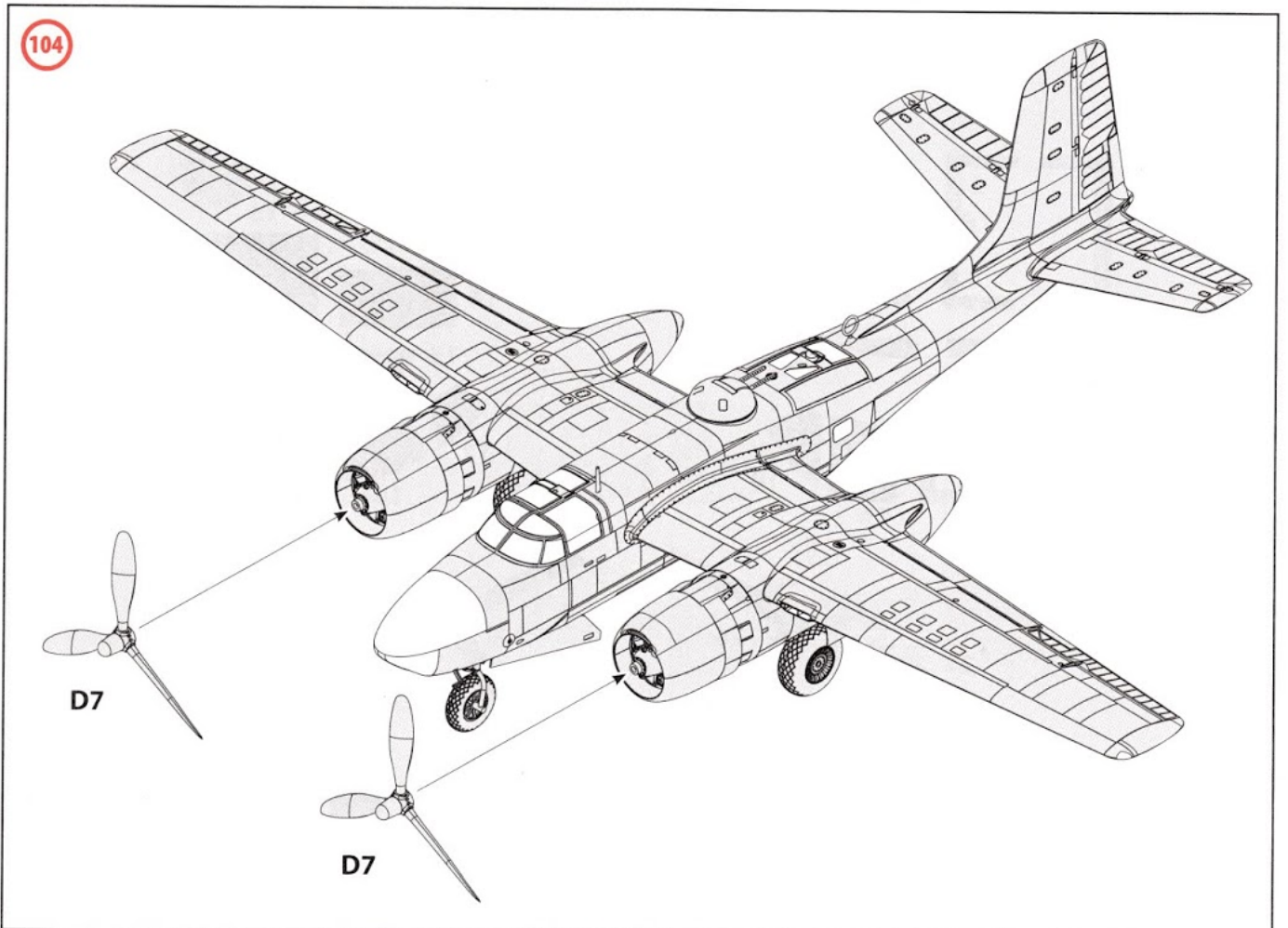
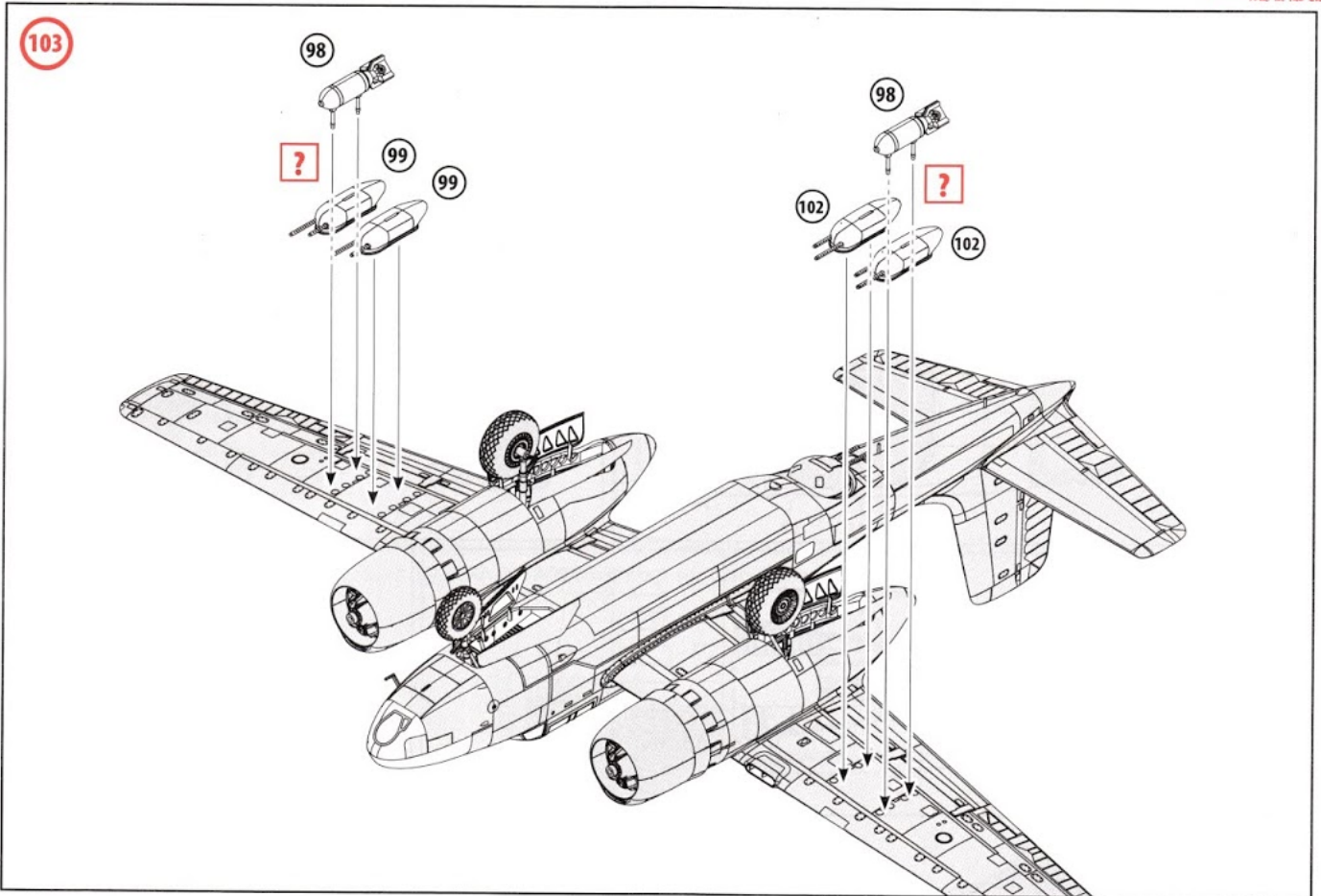

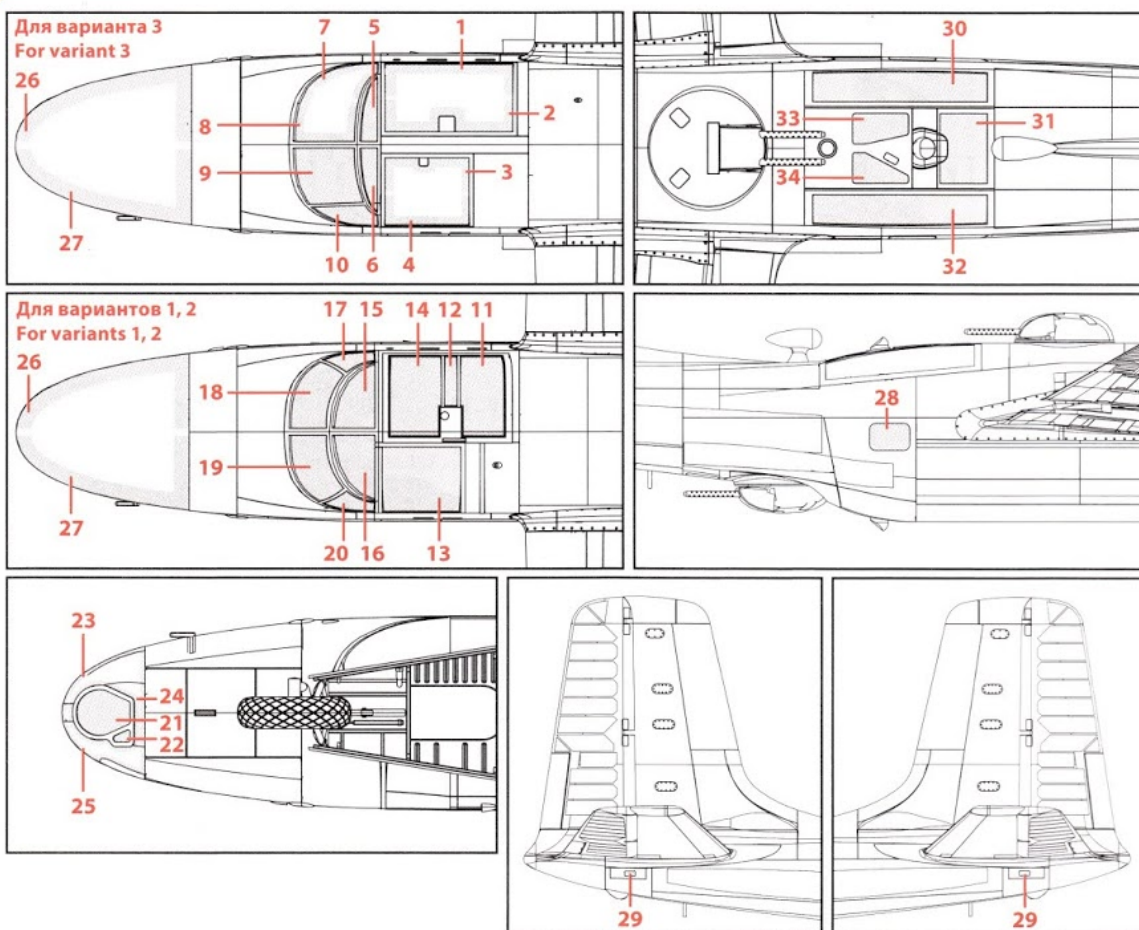

ШАБЛОНЫ МАСОК MASK TEMPLATES

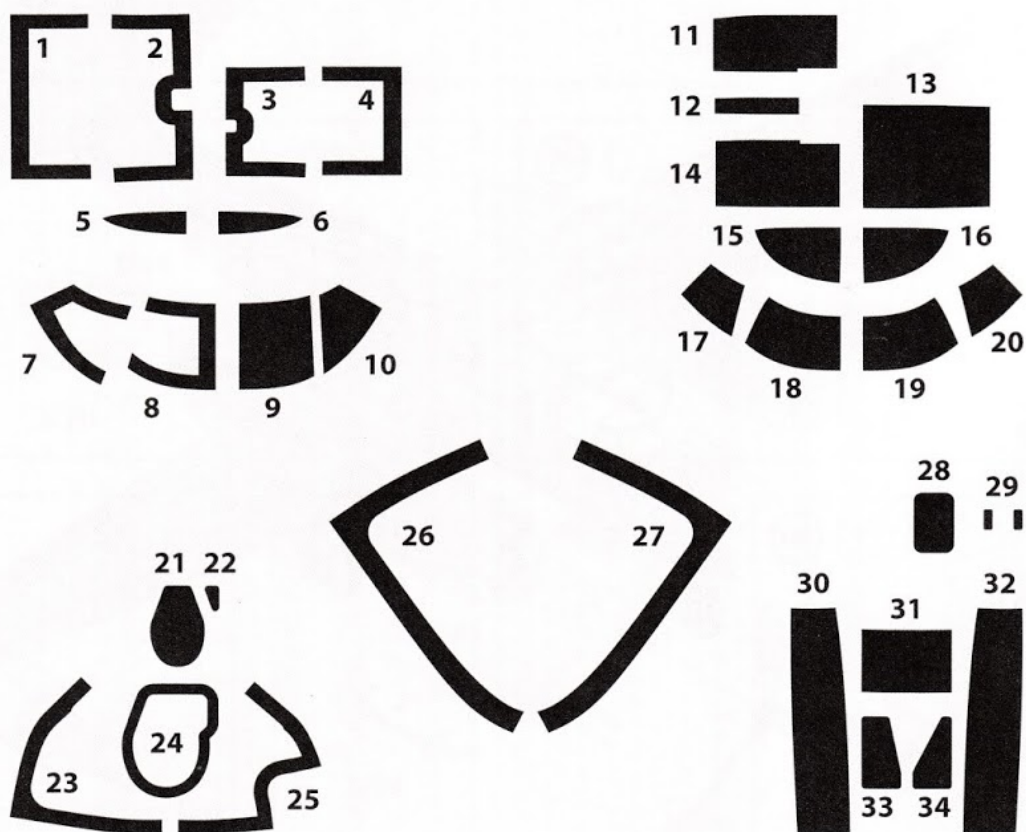

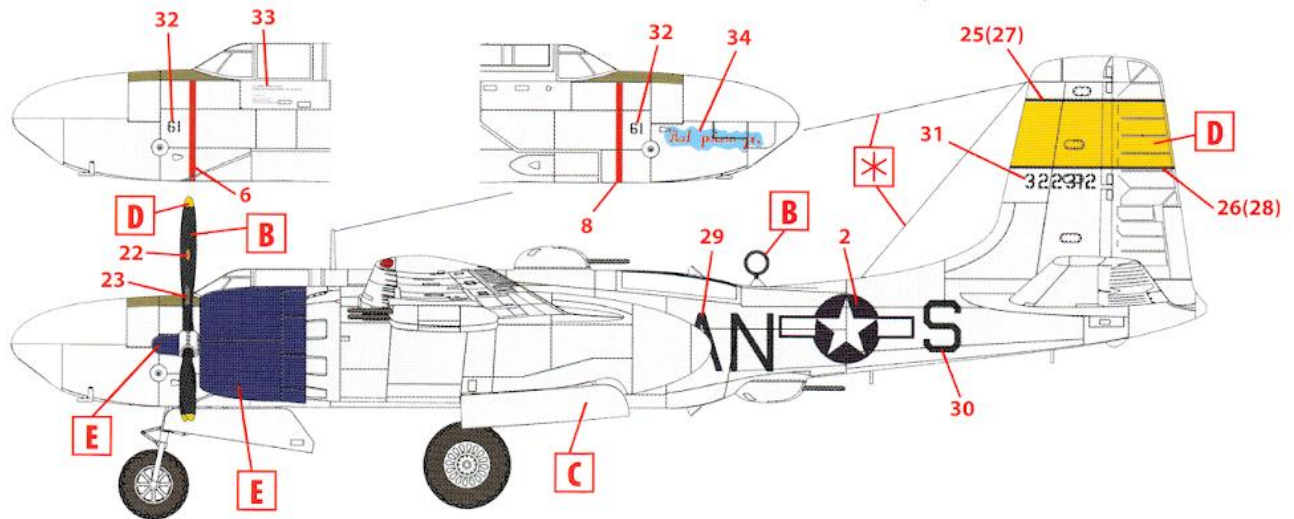

1. A-26C-16DT, 553-я эскадрилья, 386-я группа, авиабаза Бомон-сюр-О, Франция, март 1945 г.
A-26C-16DT, 553rd BS/386th BG, A60 Beaumont-sur-Oise, France, March 1945

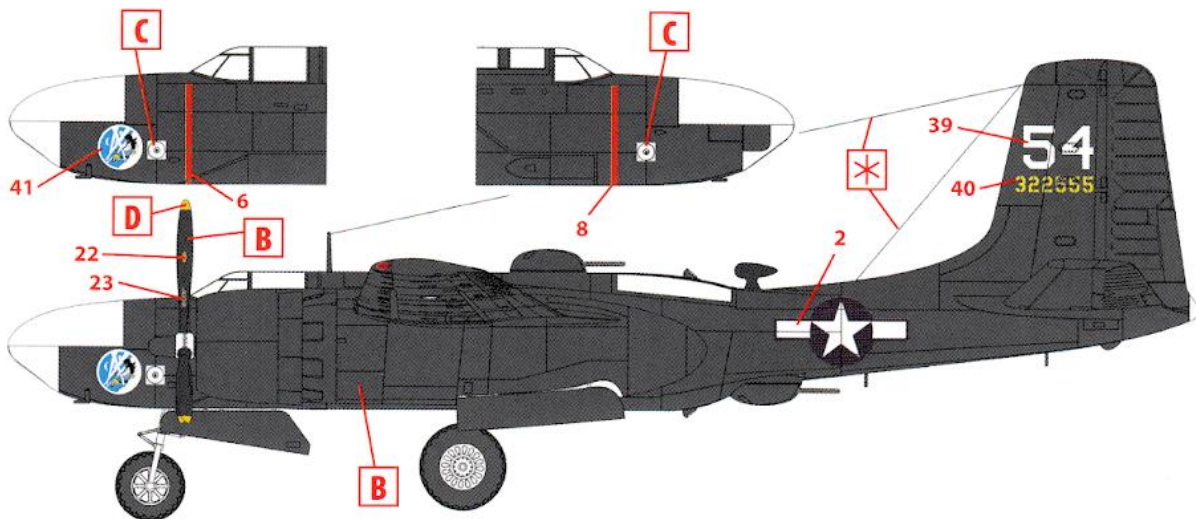

2. A-26C-20DT, 86-я эскадрилья, 47-я группа, Гроссето, Италия, начало 1945 г.
A-26C-20DT, 86th BS/47th BG, Grosseto, Italy, Early 1945

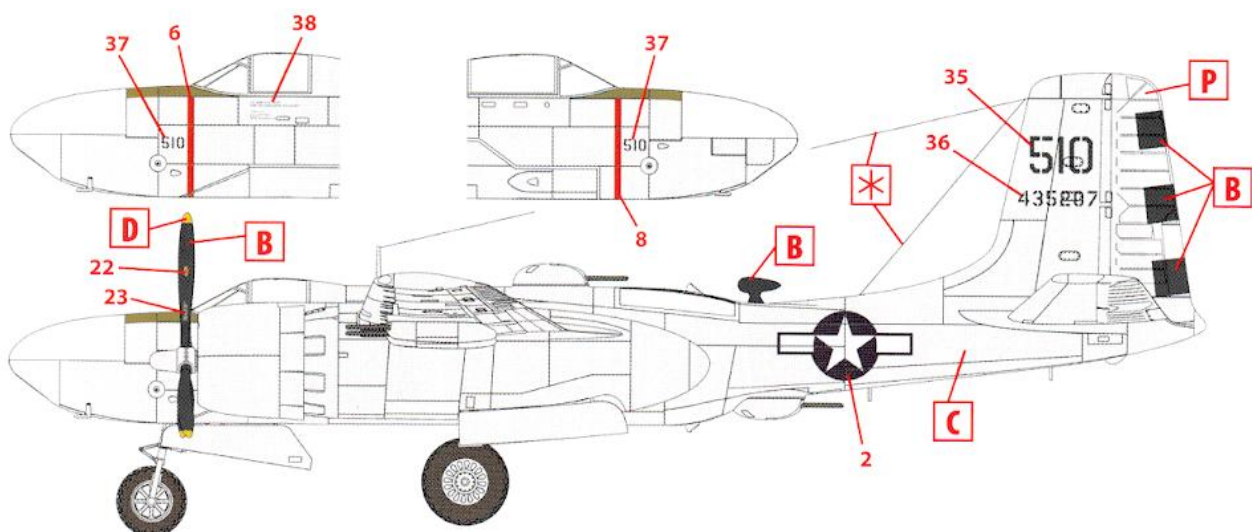

3. A-26C-30DT, 646-я эскадрилья, 410-я группа, авиабаза Бомон-сюр-О, Франция, июнь 1945 г.
A-26C-30DT, 646th BS/410th BG, A60 Beaumont-sur-Oise, France, June 1945

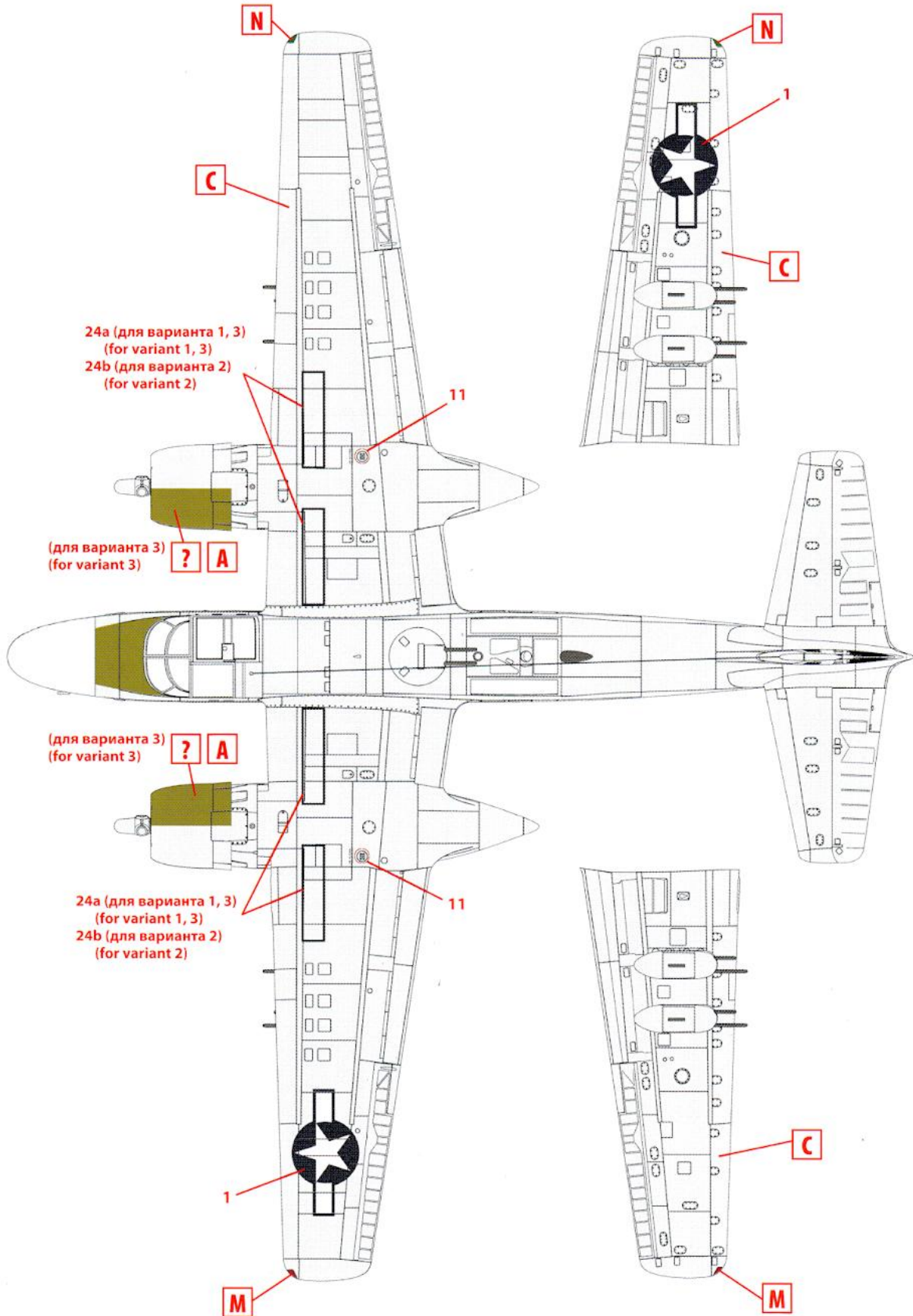

ООО ICM Холдинг
 ул. Бориспольская 9, строение 64,
 02099, Киев, Украина
 Тел./факс: +38(044) 369 54 12
 E-mail: export@icm.com.ua



ICM Holding
 Borispolskaya, 9, build. 64,
 02099, Kiev, Ukraine
 Tel./Fax: +38(044) 369 54 12
 E-mail: export@icm.com.ua