

Revell

KIT 0216

85021600200

B-25 BOMBER

The North American B-25 Mitchell bomber had a wingspan of 67' 7". Fuselage length was 52' 11". Normally during WWII this version of the B-25 carried four .50 cal. machine guns in two revolving turrets and one in the nose. The aircraft flown in the famous Doolittle raid had their lower turrets replaced by additional fuel tanks and two "dummy broomstick guns" extended from the tail to discourage attack by enemy aircraft.

The markings on your Revell Doolittle Raider B-25 bomber represent those used on the actual plane that Lt. Col. Doolittle flew himself during the raid.

Your Revell B-25 Mitchell bomber model includes revolving turrets and elevating guns, realistic details and authentic waterslide decal markings.

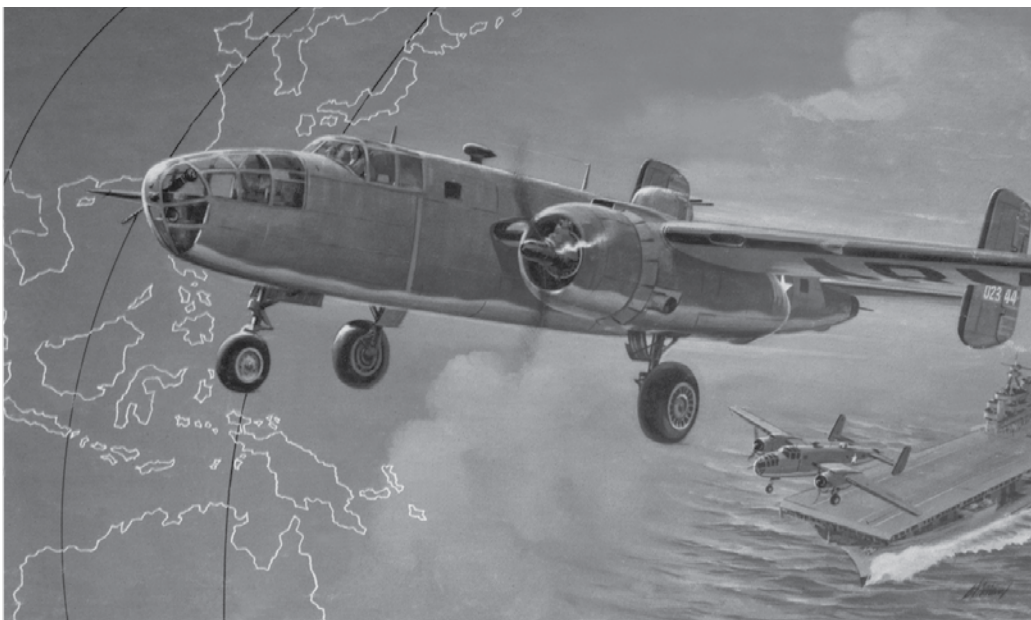

* REPEAT SEVERAL TIMES
* A REPETER PLUSIEURS FOIS



* APPLY STICKERS
* APPLIQUEZ LES AUTO-COLLANTS



* OPTIONAL PARTS
* PIÈCES EN OPTION



* ALTERNATIVE ASSEMBLY
* ENSEMBLAGE ALTERNATIVE



* REMOVE AND THROW AWAY
* A RETIRER ET JETER

READ THIS BEFORE YOU BEGIN

- * Study the assembly drawings.
- * Each plastic part is identified by a number.
- * In the assembly drawings, some parts will be marked by a star (★) to indicate chrome plated plastic.
- * For better paint and decal adhesion, wash the plastic parts in a mild detergent solution. Rinse and let air dry.
- * Check the fit of each piece before cementing in place.
- * Use only cement for polystyrene plastic.
- * Scrape plating and paint from areas to be cemented.
- * Allow paint to dry thoroughly before handling parts.
- * Any unused parts may be discarded.

DECAL APPLICATION INSTRUCTIONS

1. Cut desired decal from sheet.
2. Dip decal in water for a few seconds.
3. Place wet decal on paper towel.
4. Wait until decal is movable on paper backing.
5. Place decal in position on model, face up and slide backing away.
6. Press out air bubbles with a soft damp cloth.
7. Milkiness that may appear is for better decal adhesion and will dry clear. Wipe away any excess adhesive.
8. Do not touch decal until fully dry.
9. Allow the decals 48 hours to dry before applying clear coat.

NOTE: Decals are compatible with setting solutions or solvents.

LIRE CE QUI SUIT AVANT DE COMMENCER

- * Etudier les schémas de montage.
- * Chaque pièce en plastique est identifiée par un numéro.
- * Sur les schémas de montage, certaines pièces sont marquées d'une étoile (★) pour indiquer qu'elles sont en plastique chromé.
- * Pour une meilleure prise de la peinture et des autocollants, laver les pièces en plastique avec une solution détergente peu concentrée. Les rincer et les laisser sécher à l'air.
- * Vérifier que chaque pièce s'ajuste bien avant de la coller en place.
- * N'utiliser que de la colle pour polystyrène.
- * Gratter les parties à coller pour enlever le chrome et la peinture.
- * Laisser la peinture bien sécher avant de manipuler les pièces.
- * Toute pièce inutilisée peut être jetée.

DIRECTIVES D'APPLICATION DES AUTOCOLLANTS

1. Découper l'autocollant désiré de la feuille.
2. Tremper l'autocollant dans de l'eau pendant quelques secondes.
3. Placer l'autocollant mouillé sur une serviette en papier.
4. Attendez que l'autocollant puisse être déplacé sur son support en papier.
5. Mettre l'autocollant en position sur le modèle face sur le dessus et faire glisser le support pour l'enlever.
6. Appuyer avec un chiffon doux humide pour éliminer les bulles d'air.
7. La substance laiteuse qui peut apparaître est destinée à améliorer l'adhésion de l'autocollant et devient incolore au séchage. Essuyer pour enlever tout excédent d'adhésif.
8. Ne pas toucher l'autocollant tant qu'il n'est pas bien sec.
9. Laisser l'autocollant sécher pendant 48 heures avant d'appliquer une couche transparente.

REMARQUE: Les autocollants sont compatibles avec les solutions de fixation ou les solvants.

This paint guide is provided to complete this kit as shown on the box.

Ce guide de peinture est fourni pour reproduire le modèle réduit qui apparaît sur la boîte.

Semi Gloss Black	Noir satiné
Flat Black	Noir mat
Zinc Chromate	Vert de zinc
Silver	Argent
Flat Yellow	Jaune mat
Red	Rouge
Flat Gray	Gris mat
Tan	Havane
Flesh	Chair
Flat Brown	Brun mat

If you have any questions or comments, call our hotline at: **(800) 833-3570**
or, please write to:

Revell Inc Consumer Service Department, 1850 Howard Street Unit A, Elk Grove Village, Illinois 60007

Be sure to include the plan number (85021600200), part number, description, your return address and phone number.

Visit our website: www.revell.com

1

DECK / TURRETS / GUNNER ASSEMBLY

SEE PAINT NOTE:

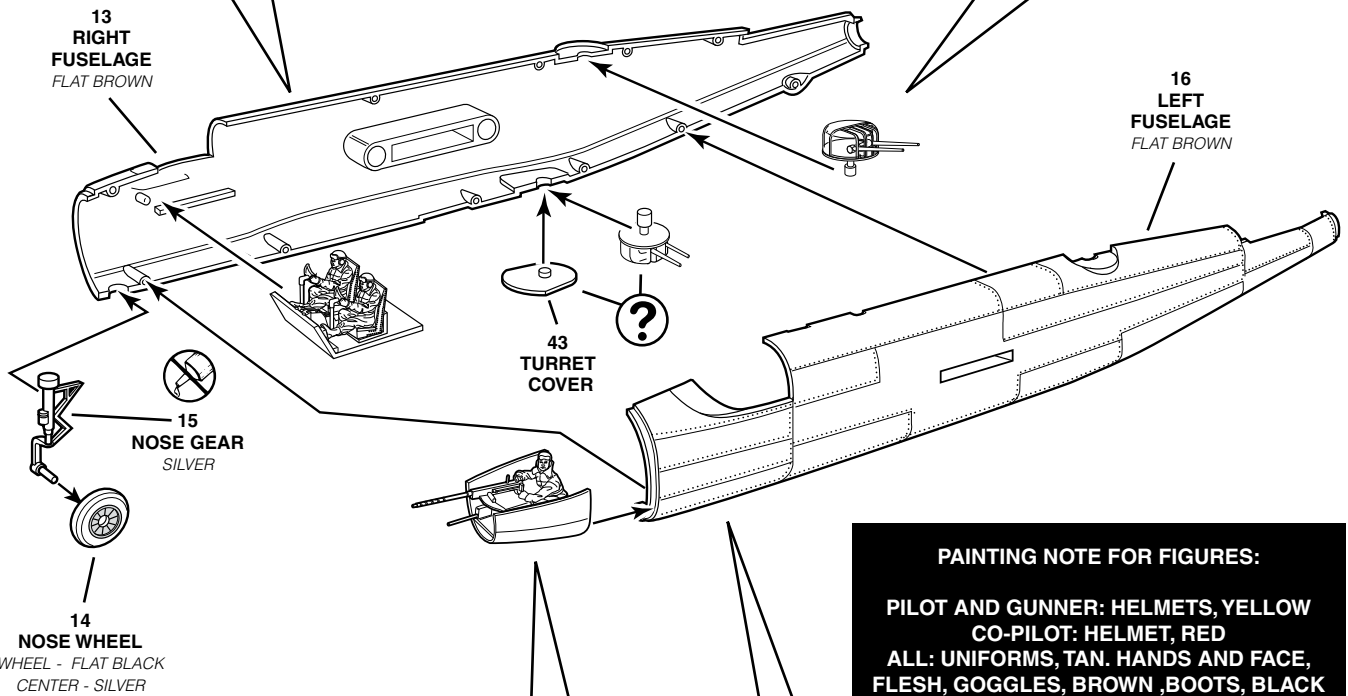
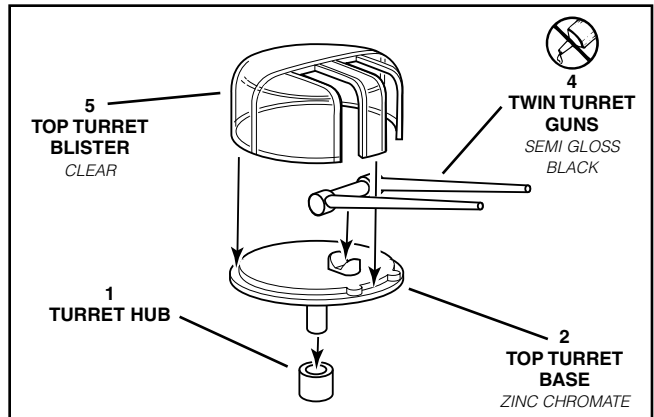
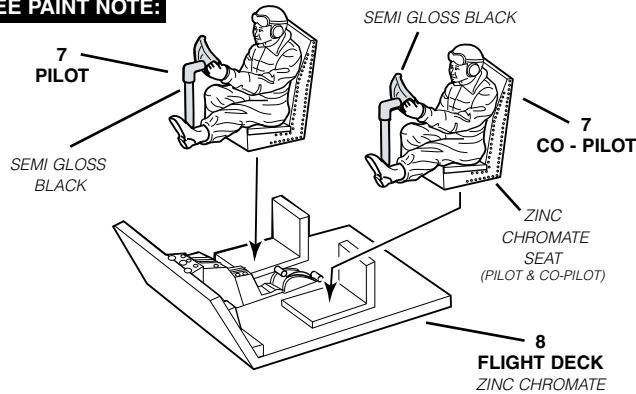

PAINTING NOTE FOR FIGURES:

PILOT AND GUNNER: HELMETS, YELLOW
CO-PILOT: HELMET, RED
ALL: UNIFORMS, TAN, HANDS AND FACE,
FLESH, GOGGLES, BROWN, BOOTS, BLACK

SEE PAINT NOTE:

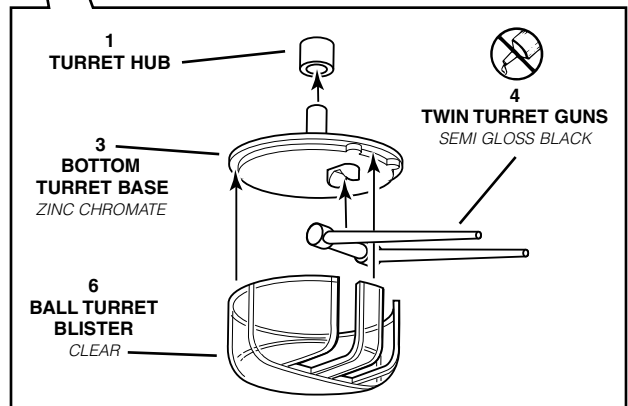
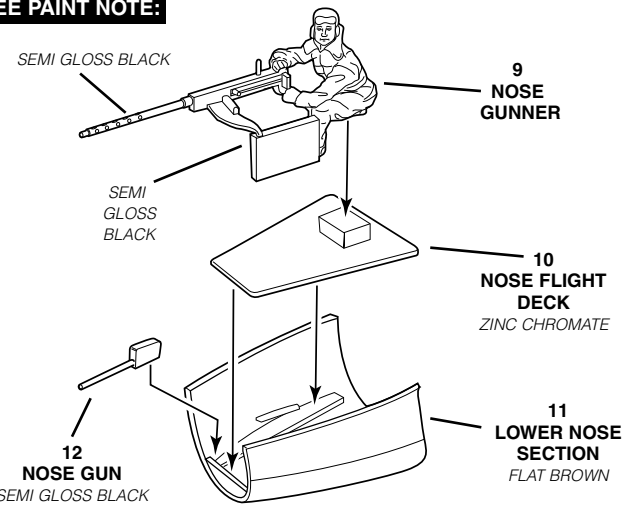

NOTE:

IF YOU WISH TO OUTFIT YOUR MODEL FOR CARRIER OPERATIONS
- AS THE PLANES FLOWN ON DOOLITTLE'S RAID - OMIT
INSTALLATION OF LOWER TURRET ASSEMBLY AND CEMENT PART
43 INTO POSITION AS SHOWN ABOVE

2

WHEEL / PROPELLER / WING ASSEMBLY

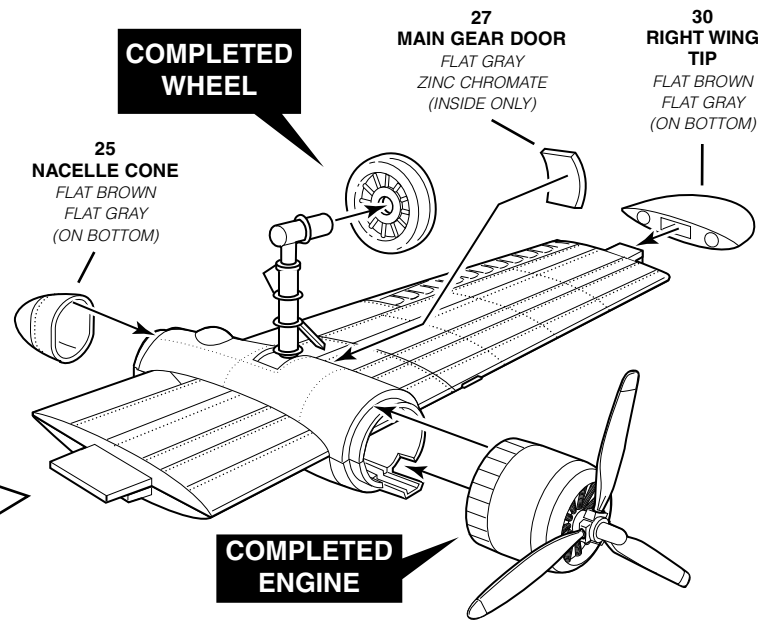
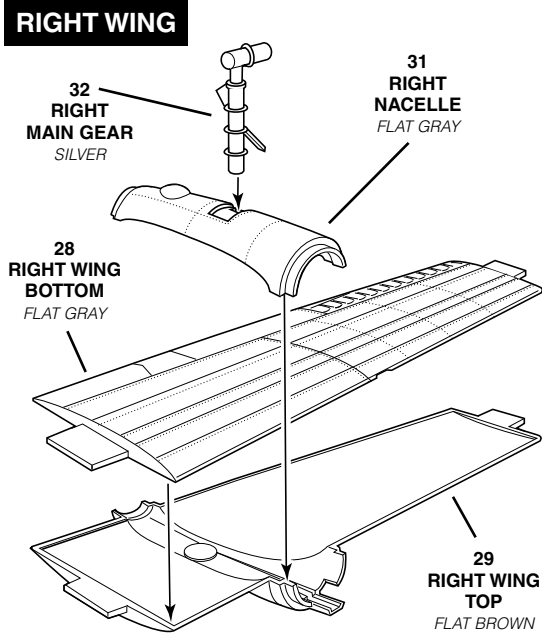
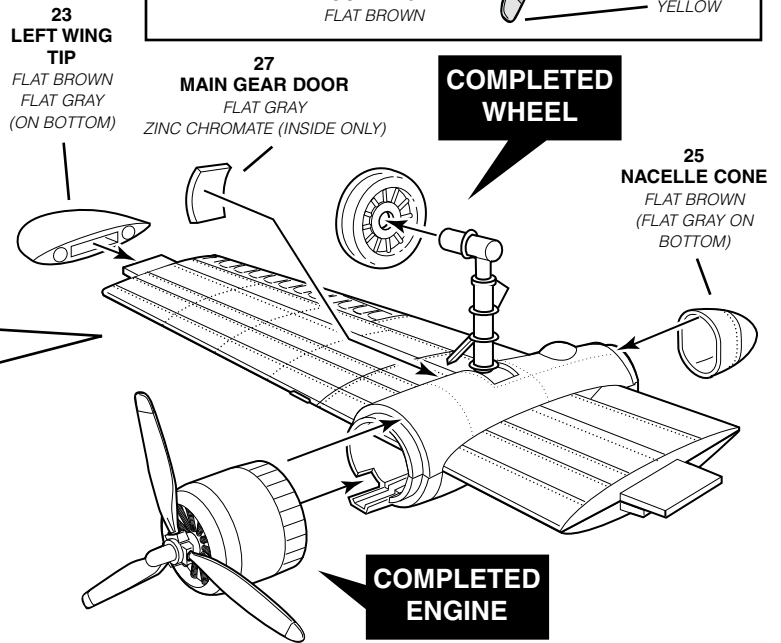
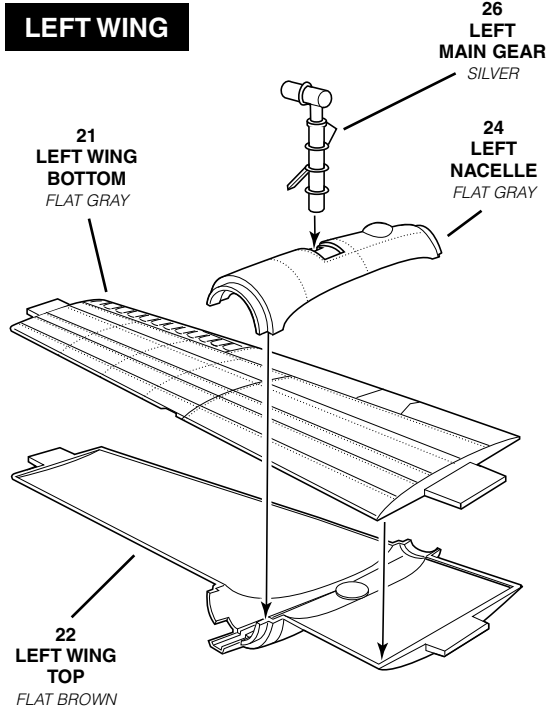
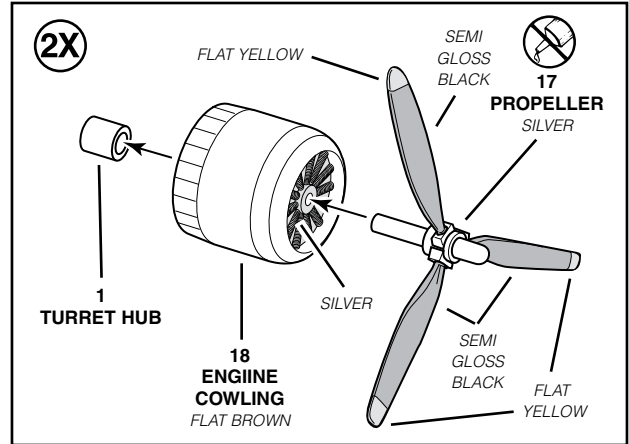
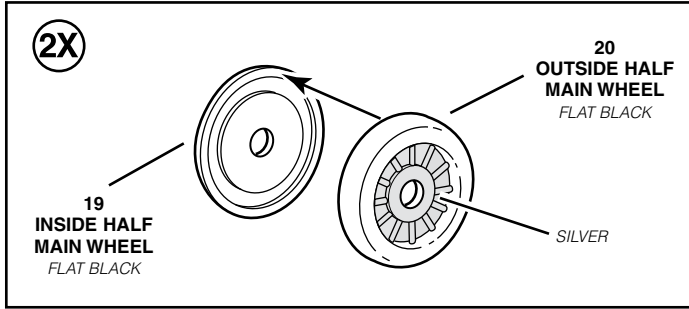

3

WING / TAIL / CANOPY ASSEMBLY

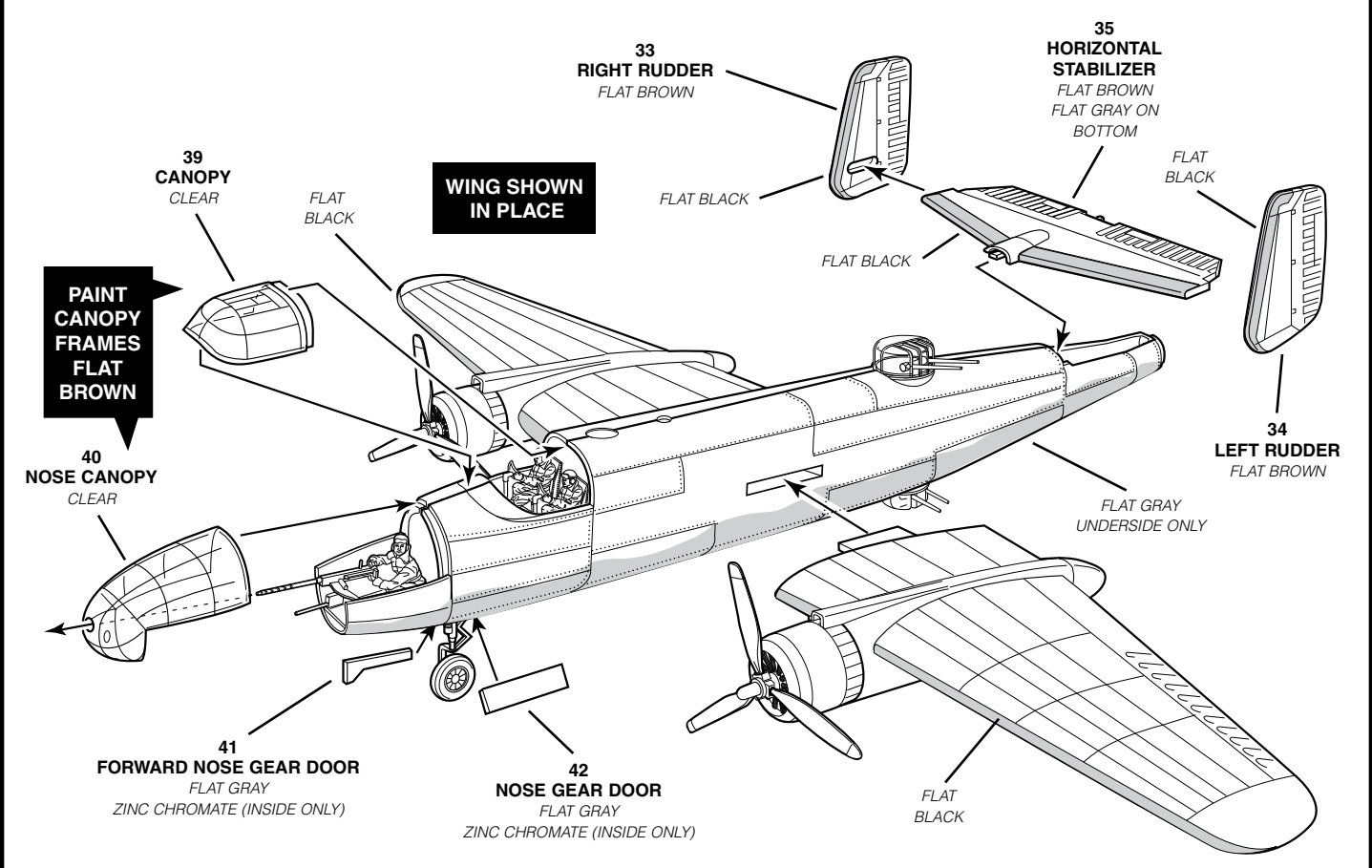

4

DECAL / FINAL ASSEMBLY

