

<Scribed Brass Parts : 106Pcs.(21001F1) / 318Pcs.(27001F1)>

- 59. Cart part 1 : 8Pcs.
- 60. Cart part 2 : 8Pcs.
- 61. Funnel Pipe A : 15Pcs.
- 62. Funnel Pipe B : 19Pcs.
- 63. Funnel Pipe C : 13Pcs.
- 64. Bitt C/D : 15Pcs.
- 65. Bitt E : 4Pcs.
- 66. Paravane Boom A : 4Pcs.
- 67. Paravane Boom B : 4Pcs.
- 68. Paravane Boom C : 8Pcs.
- 69. Paravane : 8Pcs.

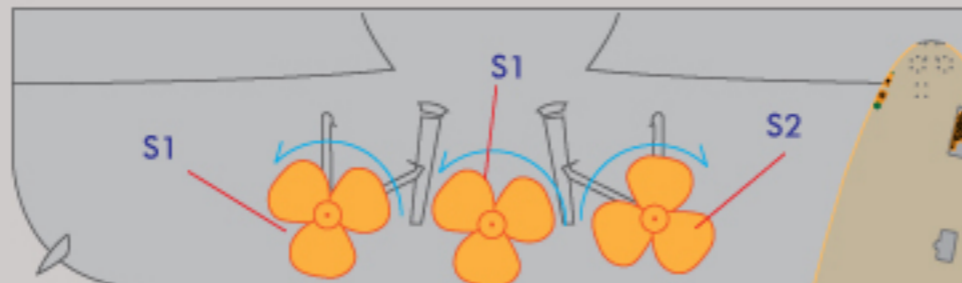

21001F1 1/200 BISMARCK 1941 ADVANCED Add-on SET
27001F1 1/200 BISMARCK 1941 ADVANCED SET

- < Contents >
1. Wooden deck : 1 Set (27001F1 Only)
 2. Scribed Brass : 106 Pcs.(21001F1) / 318Pcs.(27001F1)
 3. Photo Etching : 5 Sheets(21001F1) / 15Sheets.(27001F1)
 4. Resin Parts : 5Pcs.(21001F1) / 27Pcs.(27001F1)
 5. Life Tubes : 25 Pcs(27001F1 Only)
 6. Dry Transfer : 1 Sheet(27001F1 Only)

<Paravane : 8 sets>

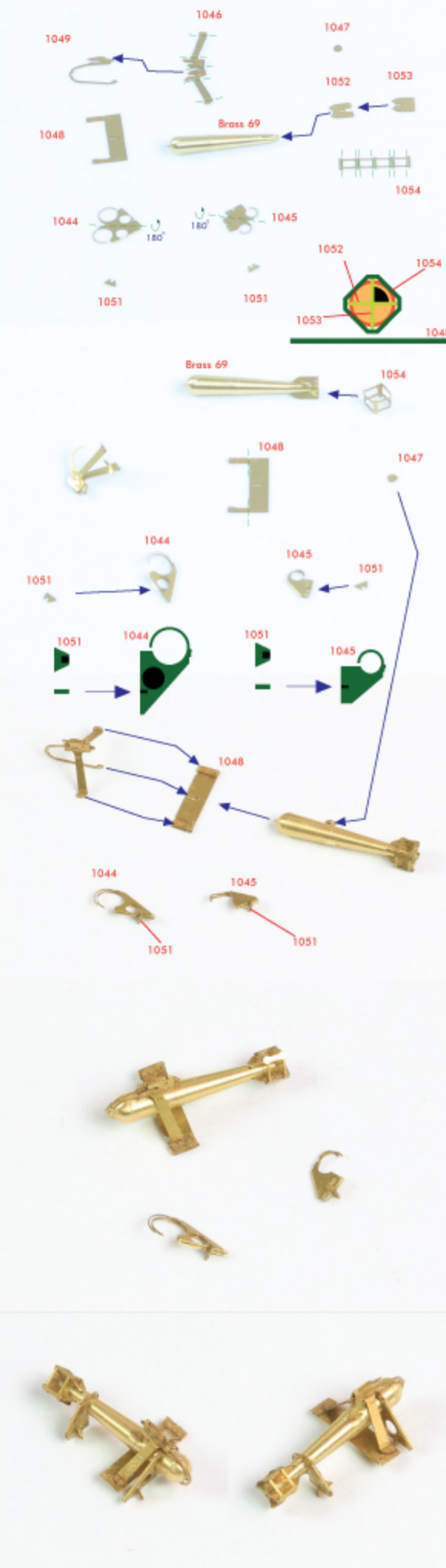

<Bitt C : 5 sets>



<Bitt D : 5 sets>



<Starlights>



<References>

1. Hans Gdly, Bismarck : 1:100 Master Plan, Malch
2. Josef Kaiser, Schlachtschiff Bismarck - Das Original im Detail, Düsseldorf, SmeckeVerlag, 2004
3. Por Philippe Coréau, Le Croiseur Bismarck, Outreau, Lela Presse, 2003
4. Wiktor Góralski / Grzegorz Nowak The Battleship Bismarck : Super Drawing in 3D, Lublin, Kagran, 2010
5. Miroslaw Skwiat, German Naval Guns 1929-1945, Barnsley, Seaforth Publishing, 2010
6. Jack Brown, The Battleship Bismarck : Anatomy of the ship, London, Conway maritime Press, 2005

<Resin Cutters>



<Paravane Boom A : 4Pcs.>

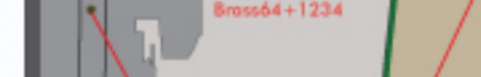

<Paravane Boom B : 4Pcs.>

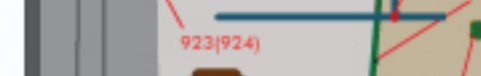

<Paravane Boom C : 8Pcs.>



<Paravane : 8Pcs.>



<Life Tubes : 25 Pcs(27001F1 Only)>

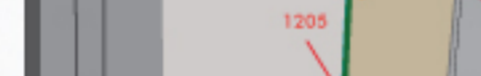

<Dry Transfer : 1 Sheet(27001F1 Only)>



<Funnel Pipes : 47Pcs.>



<Cart Parts : 16Pcs.>



<Scribed Brass Parts : 106Pcs.(21001F1) / 318Pcs.(27001F1)>



<Photo Etching : 5 Sheets(21001F1) / 15 Sheets(27001F1)>



<Resin Parts : 5Pcs.(21001F1) / 27Pcs.(27001F1)>



<Life Tubes : 25 Pcs(27001F1 Only)>



<Dry Transfer : 1 Sheet(27001F1 Only)>

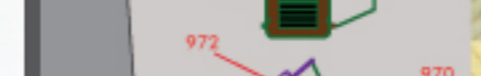

<Funnel Pipes : 47Pcs.>

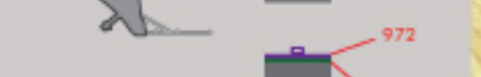

<Cart Parts : 16Pcs.>

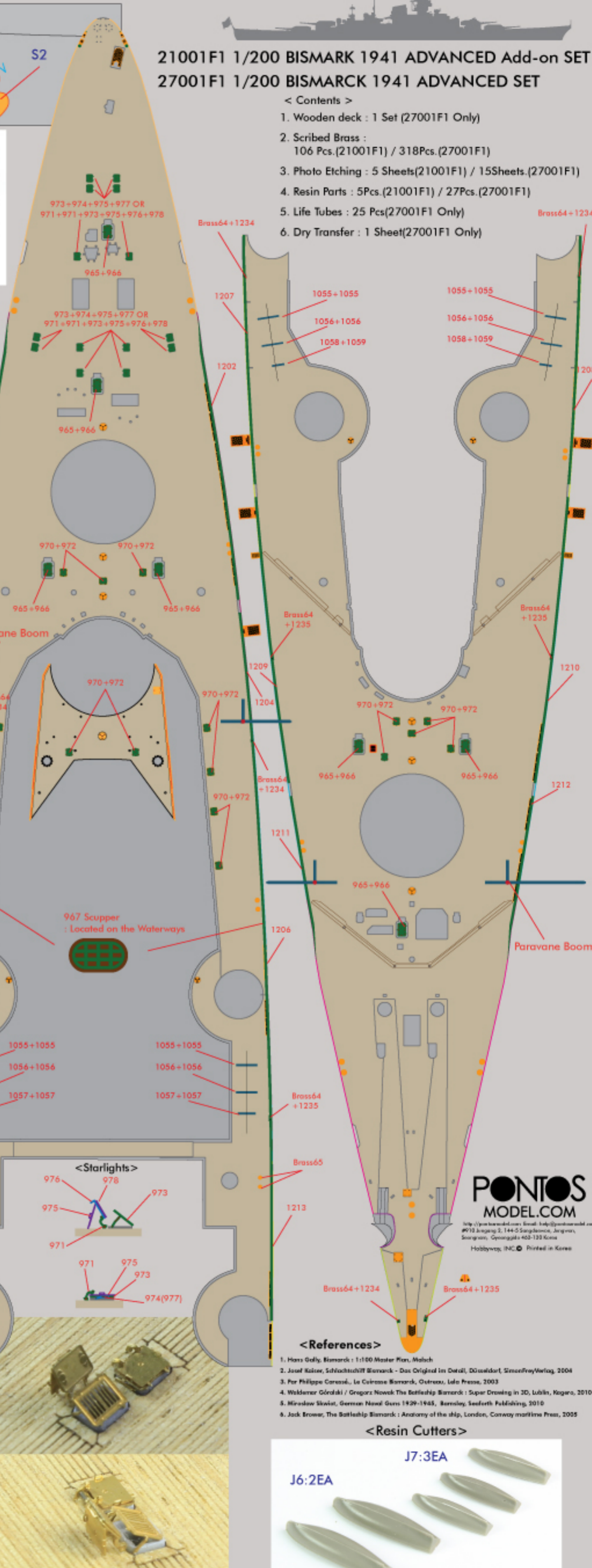
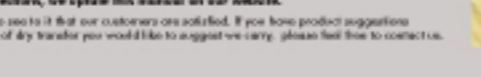

PONTOS MODEL.COM
http://www.pontosmodel.com Email: info@pontosmodel.com
#918 Sangyeon 2, 144-5 Sanghwan, Jungwon, Seongnam, Gyeonggi-do 463-133 Korea
Hobbyway, INC. Printed in Korea

For better information or corrections, we update this manual on our website.
Pontos Model makes every effort to reach it that our customers are satisfied. If you have product suggestions or if there is a particular product of dry transfer you would like to suggest on any, please feel free to contact us.

<Paravane Boom : 2+2 sets>

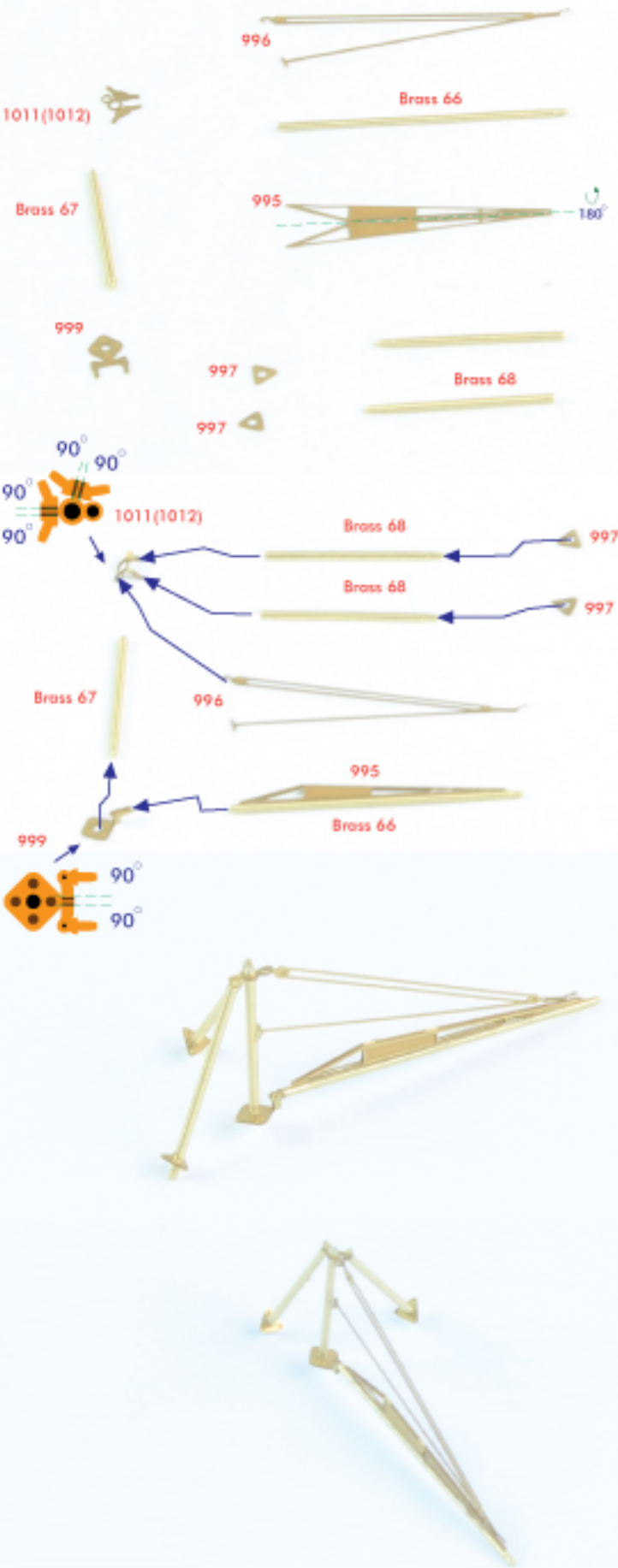

<Vent Louvres>

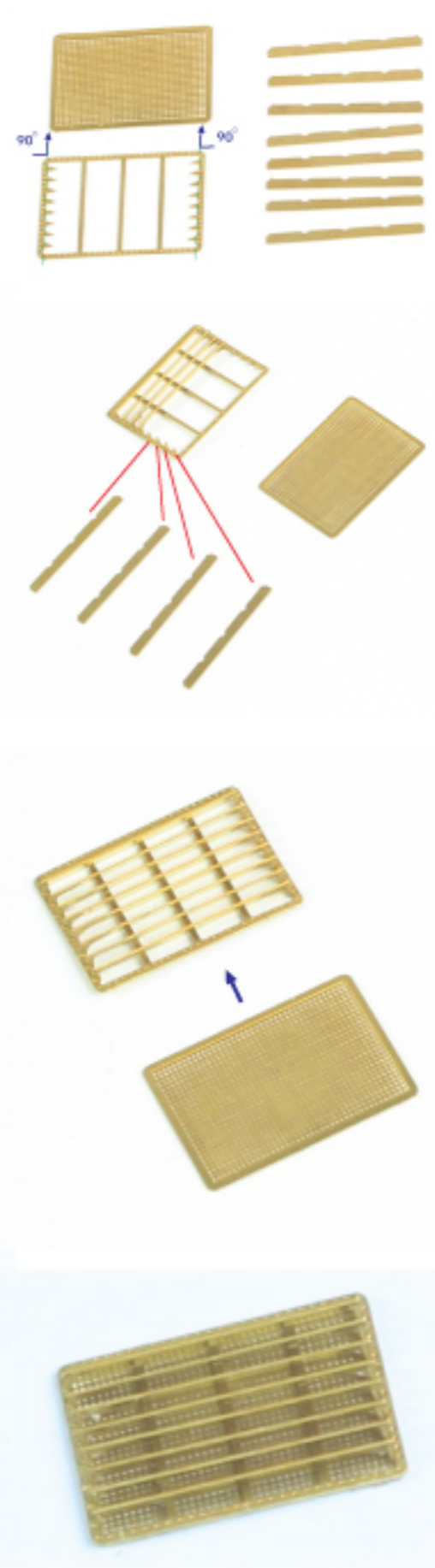

<Funnel Pipes>

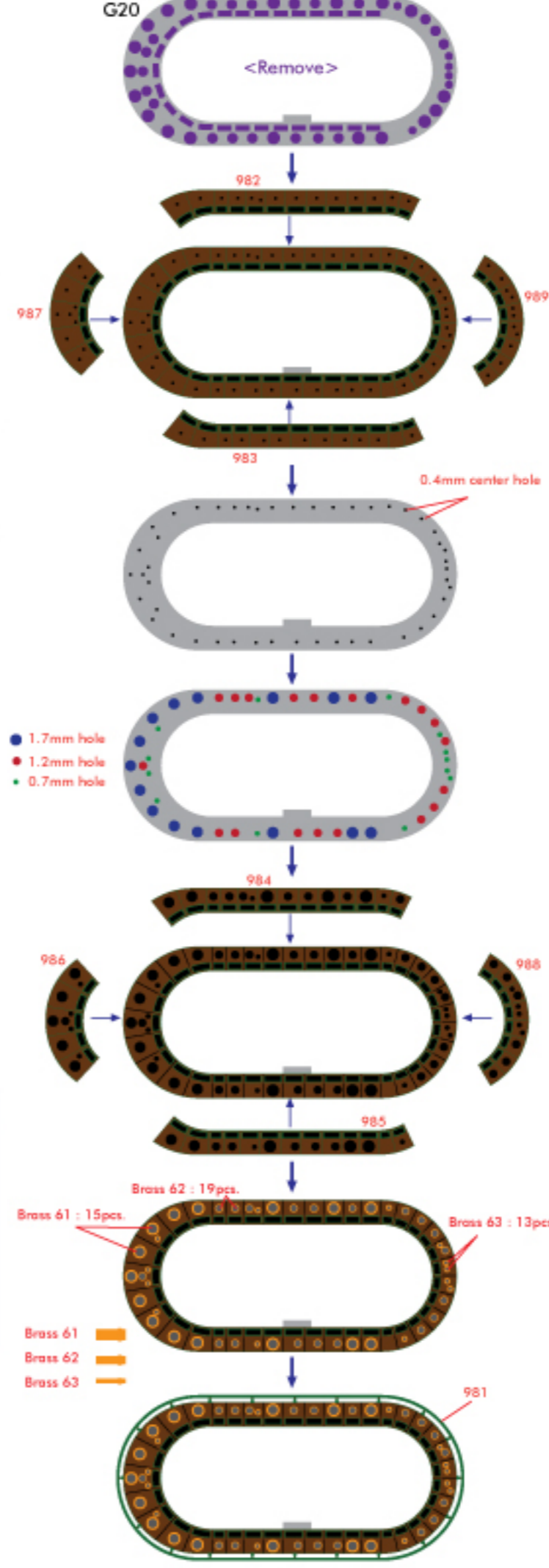

<Resin 8m Cutter J6 : 2 sets>

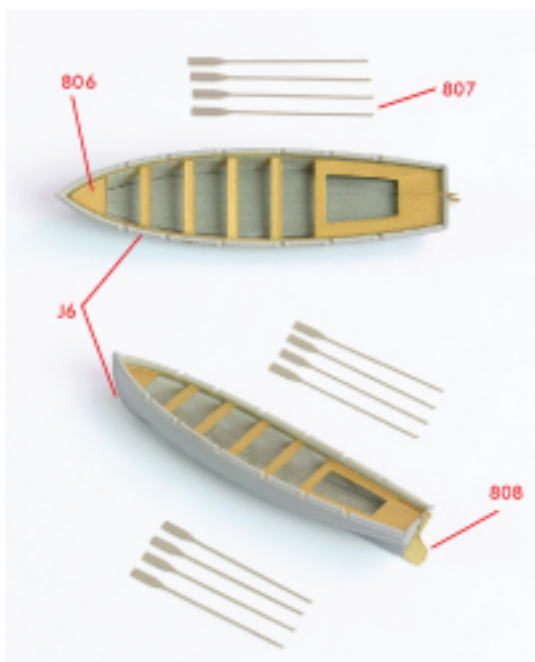

<Resin 6m Cutter J7 : 3 sets>

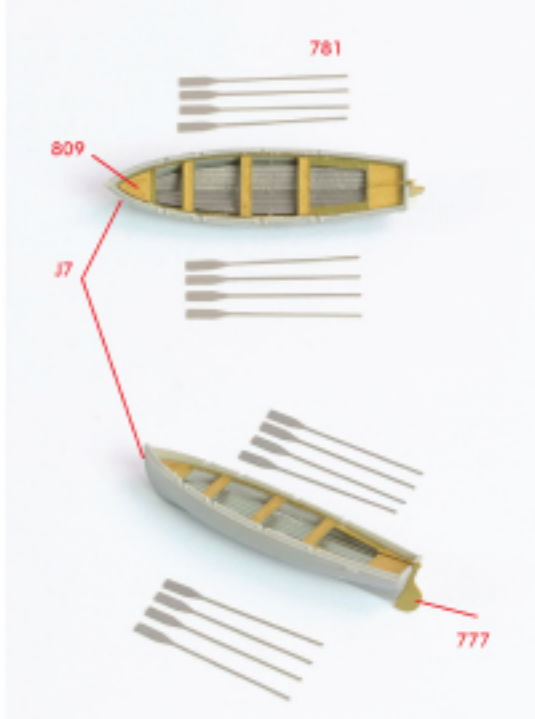

<Cart>

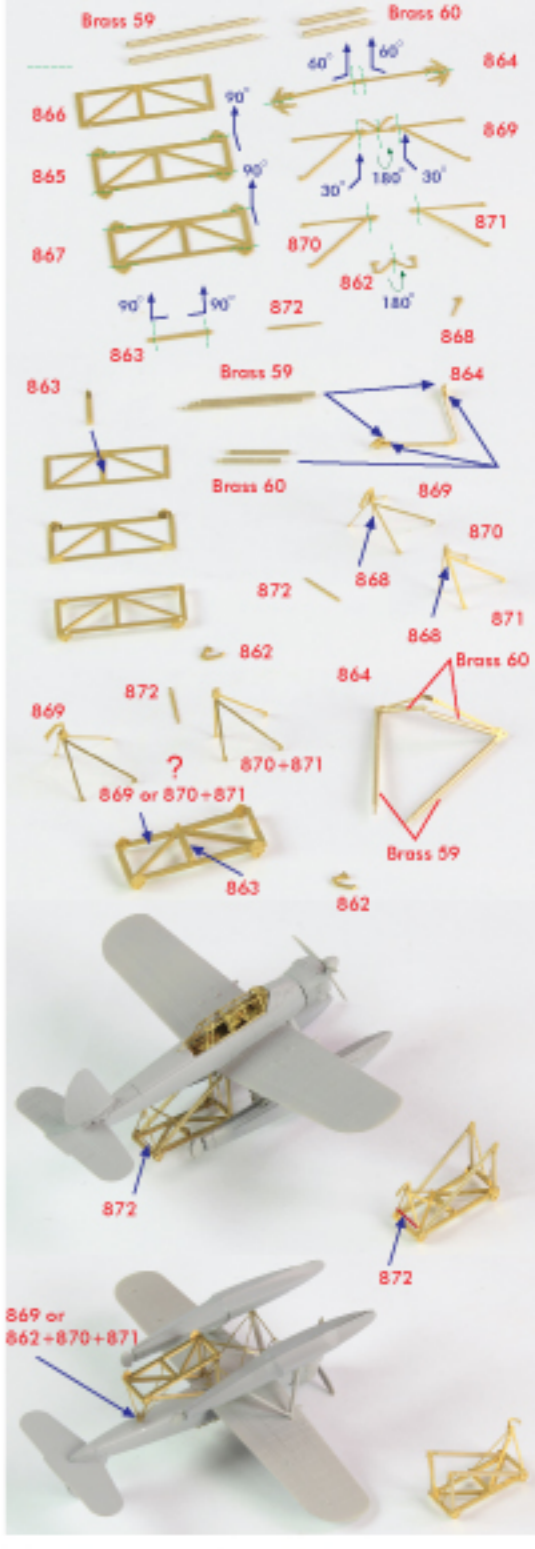

<Arado Hanger Rails>

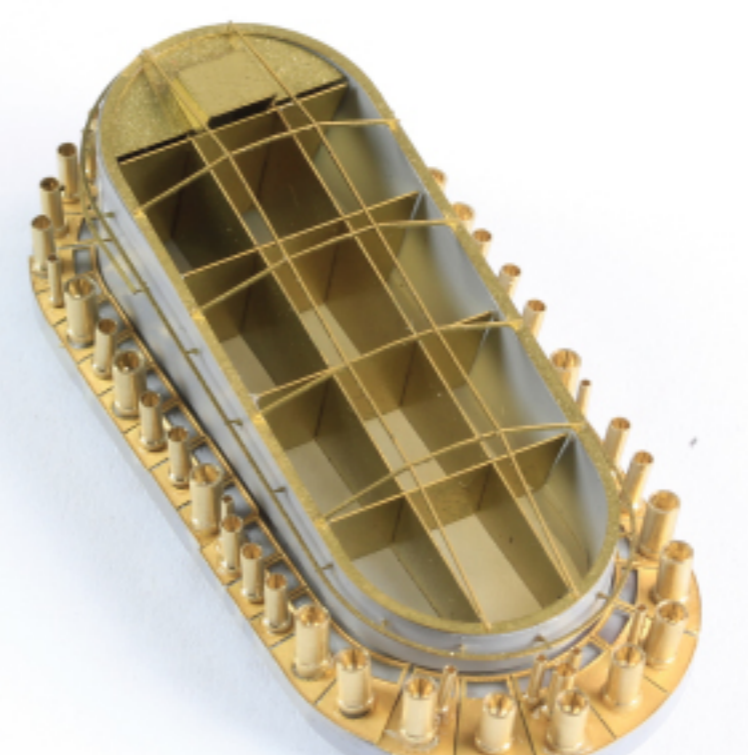
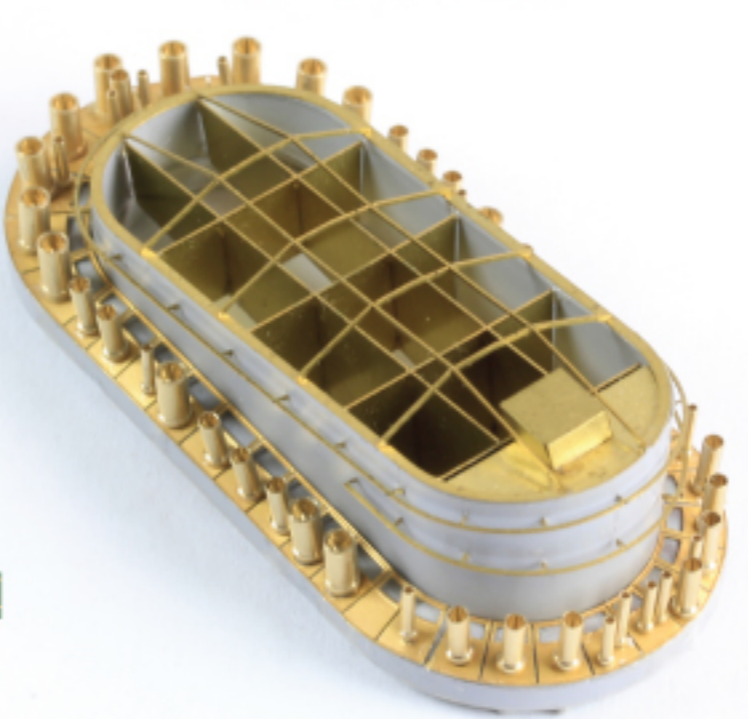
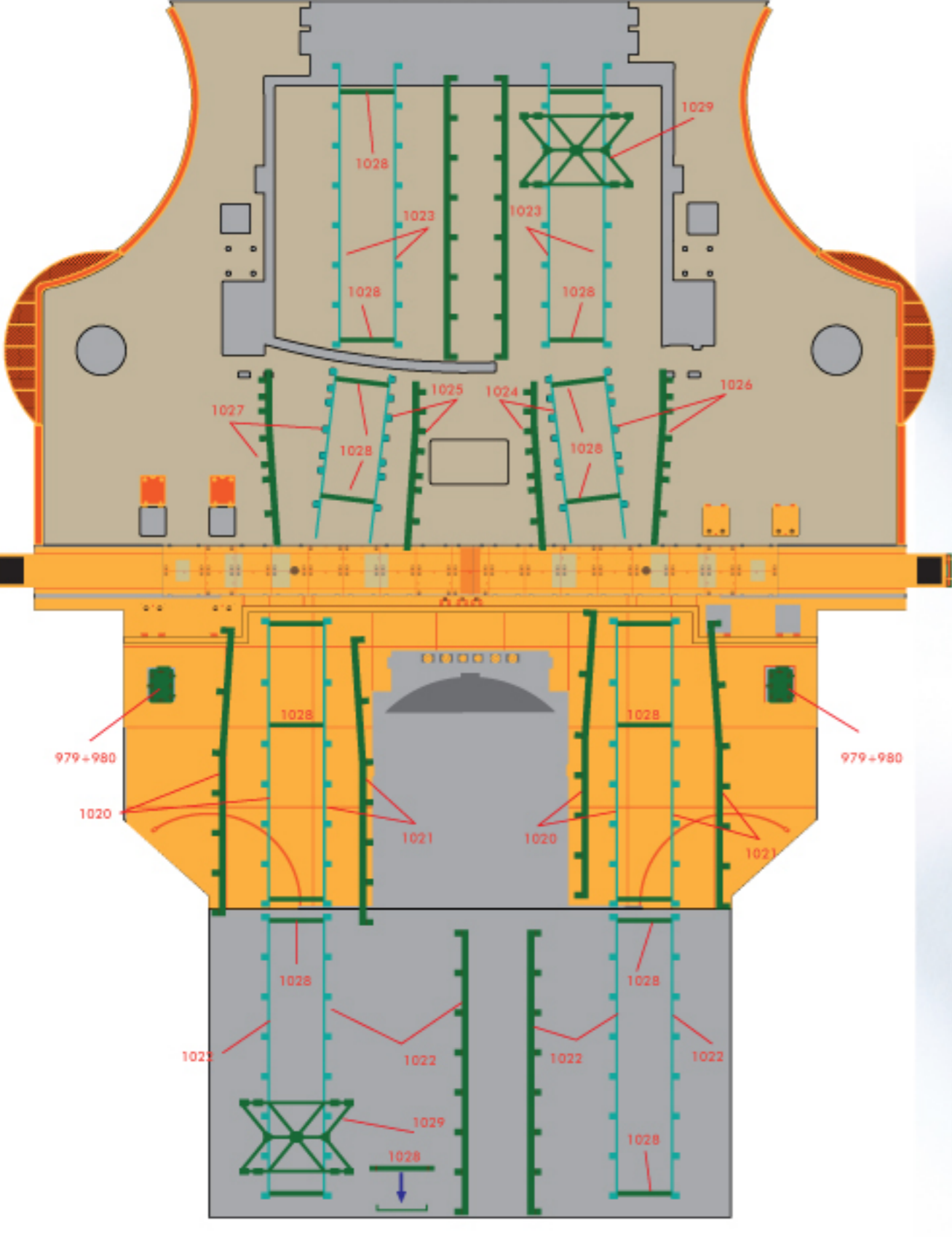

<Door of Searchlight Dome>

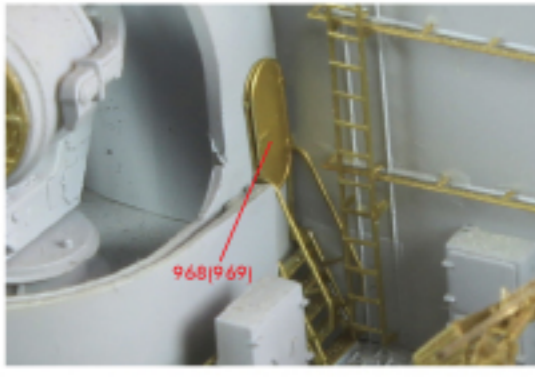

<Sd.Ah.51 Trailer>

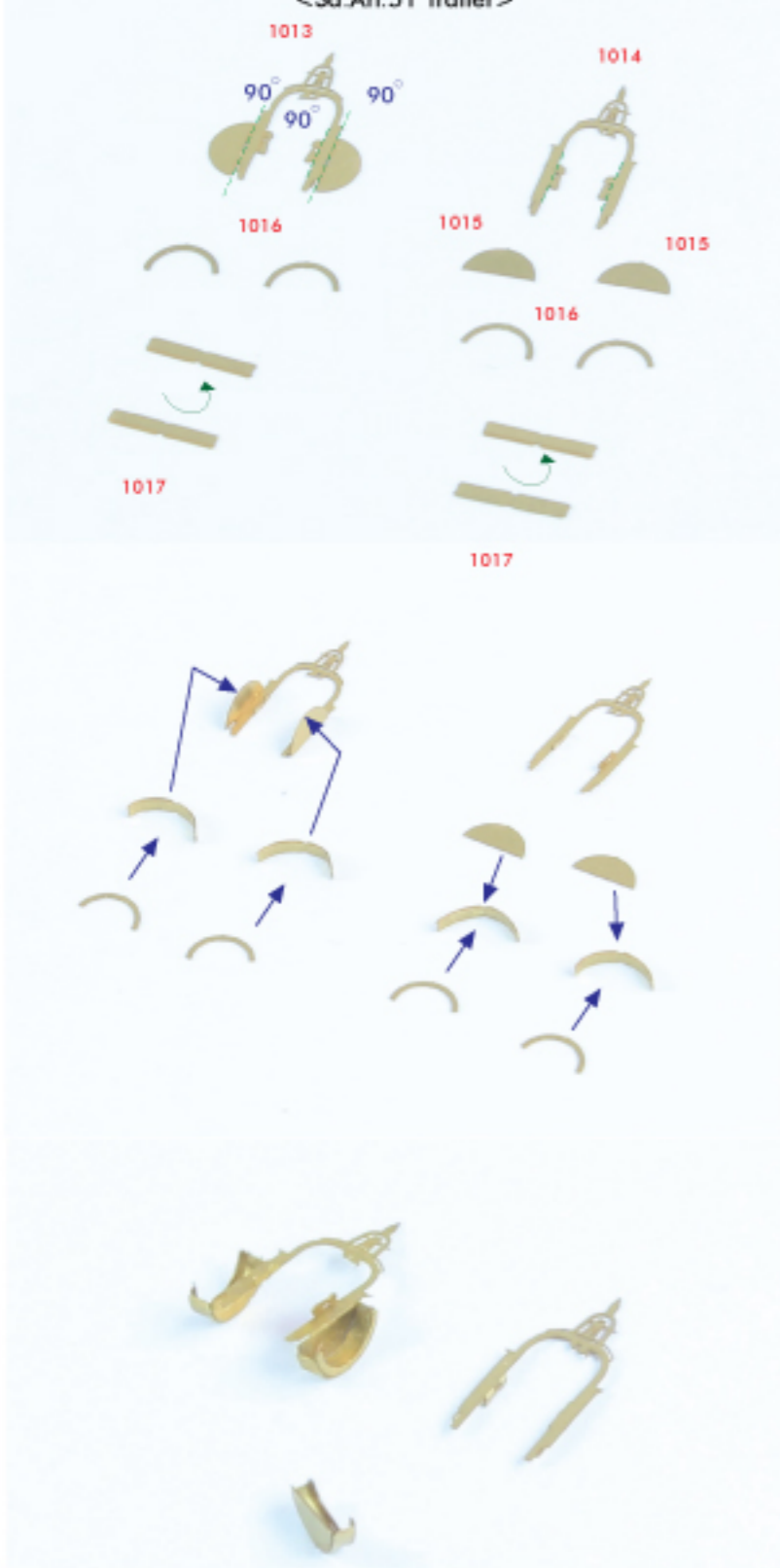

<Catapult Catwalks>

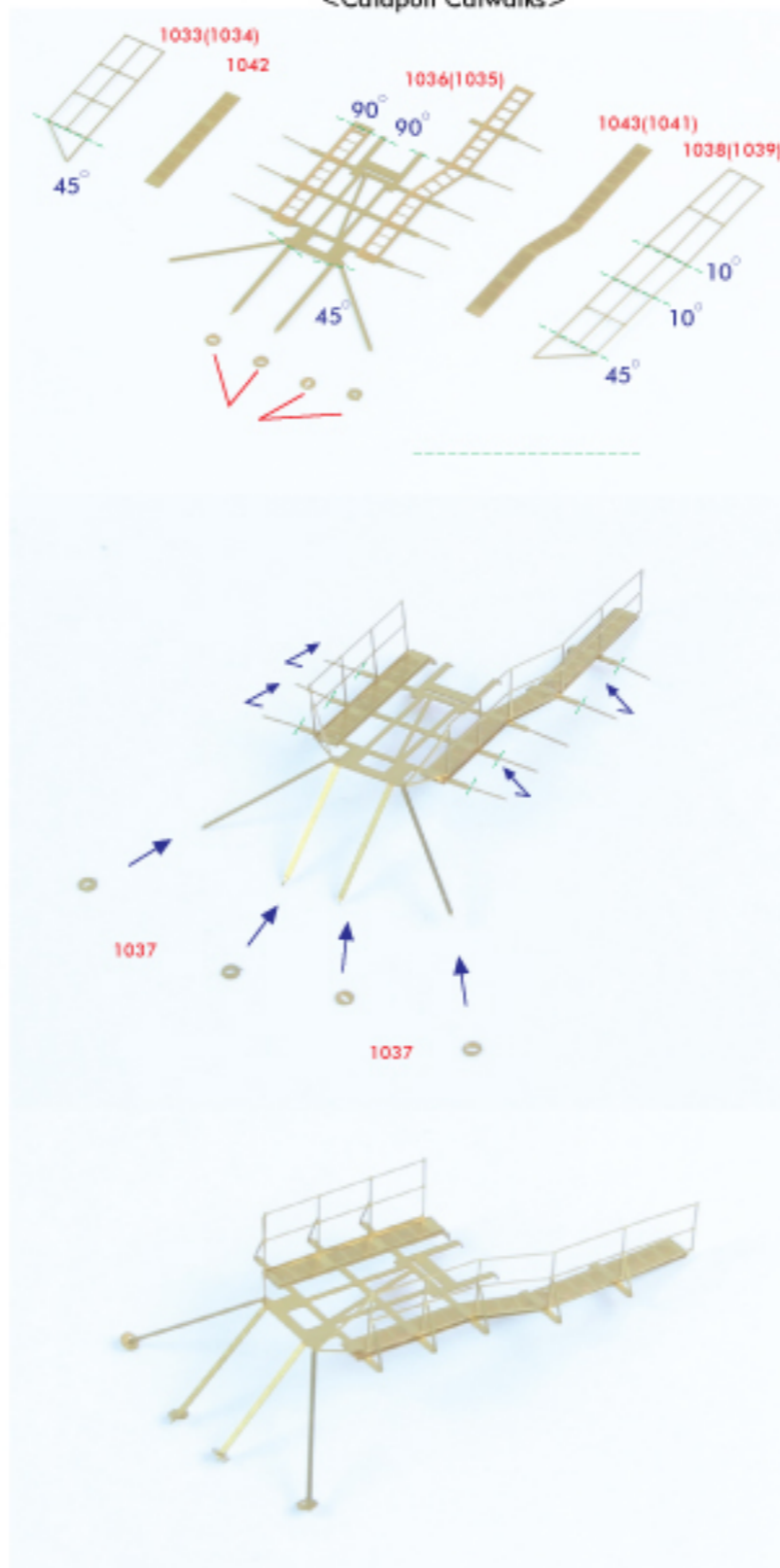

<Signal Light Guard Rails>

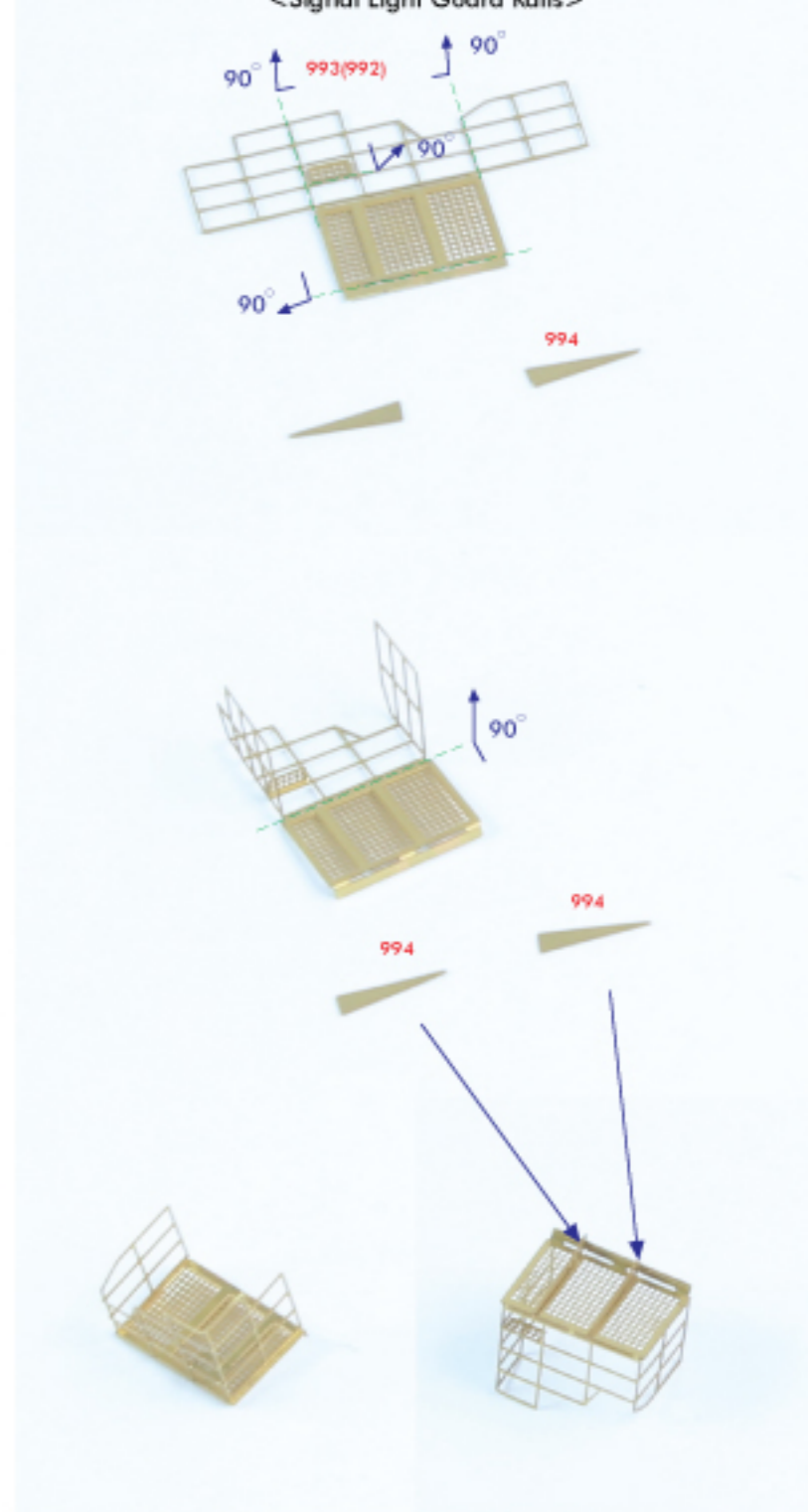

<Wire Stand on the Bow>

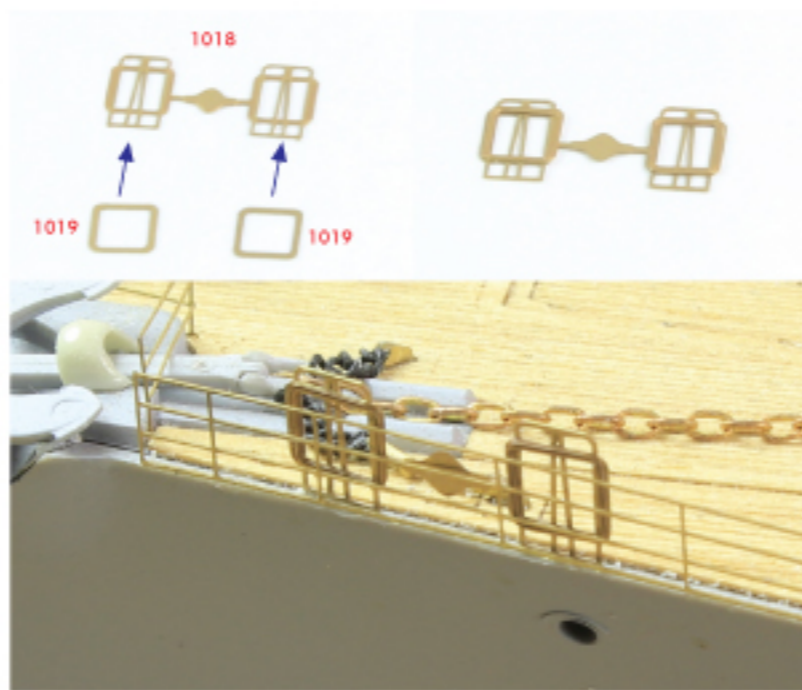

<Boat Crutches>

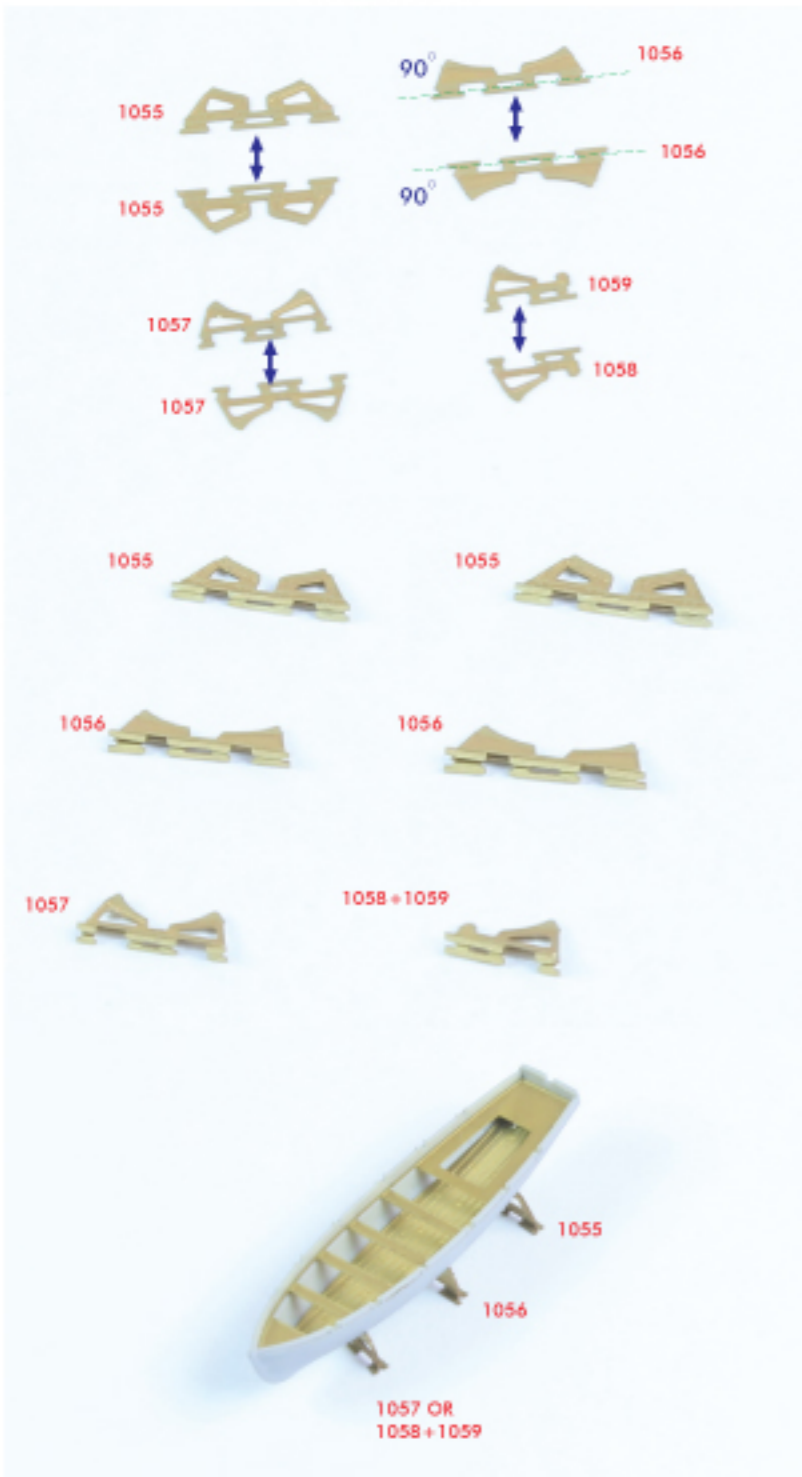

<Fire Hose>

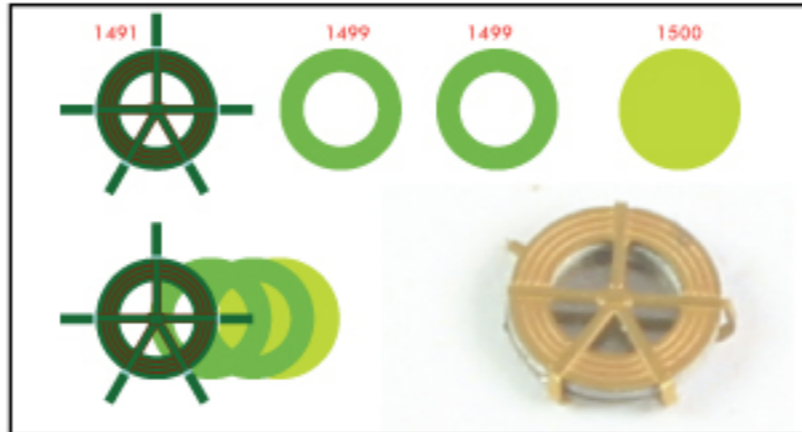

<Rigging Connectors>

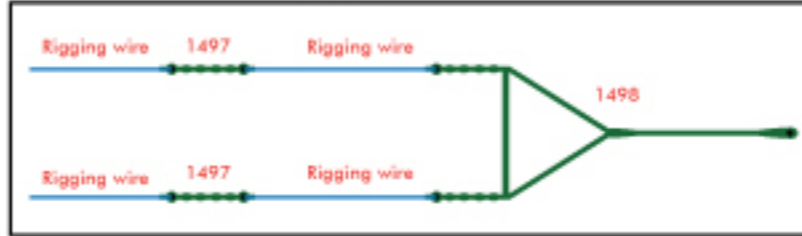

<Wire Rail>

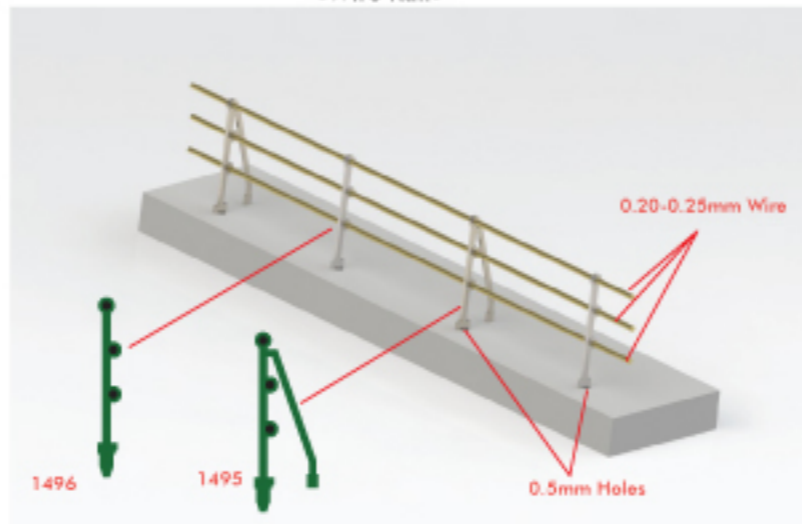

<Phone Booth :) >

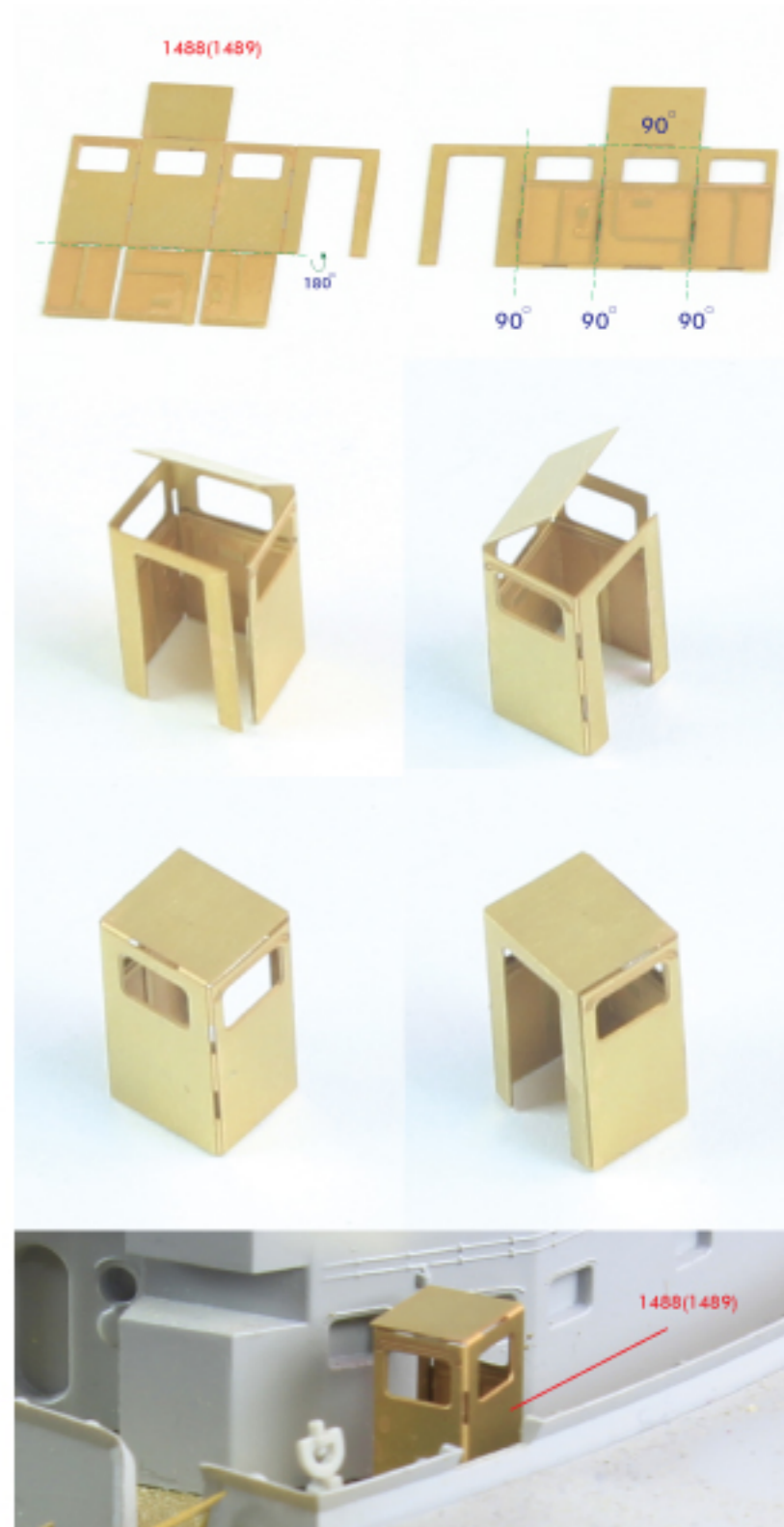

<Scribed Brass Parts : 220Pcs.(ver.2) / 212Pcs.(ver.1) >

- 01. 380mm Main Barrel : 8Pcs.
- 02. 150mm Barrel : 12Pcs.
- 03. 150mm Axis : 12Pcs.
- 04. 105mm-31 Barrel : 8Pcs.
- 05. 105mm-37 Barrel : 8Pcs.
- 06. 37mm Barrel : 16 Pcs.
- 07. 20mm A Barrel : 18 Pcs.
- 08. 20mm B Barrel : 2 Pcs.
- 09. 20mm Base : 10 Pcs.
- 10. 20mm F30 Base : 6Pcs.
- 11. Fore Mast : 1Pc.
- 12. Main Top Mast : 1Pc.
- 13. Main Mast Mid : 1Pc.
- 14. Main Mast Base : 1Pc.
- 15. Aft Mast : 1Pc.
- 16. Yardarm 1 : 3 Pcs.
- 17. Yardarm 2 : 1 Pc.
- 18. Yardarm 3 : 1 Pc.
- 19. Yardarm 4 : 2 Pcs.
- 20. Yardarm Center 1 : 1 Pc.
- 21. Yardarm Center 2 : 1 Pc.
- 22. Fore Mast Part : 1Pc.
- 23. Yardarm Bridge 1 : 2Pcs.
- 24. Yardarm Bridge 2 : 2Pcs.
- 25. Catapult Axis : 2 Pcs.
- 26. Catapult Main : 2 Pcs.
- 27. Catapult Rear : 2 Pcs.
- 28. Catapult Front : 2 Pcs.
- 29. Catapult Wheel Axis 1 : 4 Pcs.
- 30. Catapult Wheel Axis 2 : 4 Pcs.
- 31. Staff Bow : 1 Pc.
- 32. Strut Etc. : 6 Pcs.
- 33. Staff Stern : 1 Pc.
- 34. Staff Stern Strut 1 : 2 Pcs.
- 35. Staff Stern Strut 2 : 2 Pcs.
- 36. Staff Stern Boom : 2 Pcs.
- 37. Staff Stern Center : 1 Pc.
- 38. Crane Main Wheel Axis : 2Pcs.
- 39. Crane Top Wheel Axis : 2Pcs.
- 40. Crane Damper : 4Pcs.
- 41. Bell : 1Pc.
- 42. Derrick 1 : 2Pcs.
- 43. Derrick 2 : 2Pcs.
- 44. Derrick 3 : 2Pcs.
- 45. Derrick 4 : 2Pcs.
- 46. Horn Axis : 1Pc.
- 47. Horn : 1Pc.
- 48. Fore Mast Supporter 1 : 2Pcs.
- 49. Fore Mast Supporter 2 : 2Pcs.

23001F2/22001F2(Ver.2) 23001F1/22001F1(Ver.1)
1/200 BISMARCK 1941 DETAIL UP SET Basic

- 50. Bitt Large : 10 Pcs.
- 51. Bitt Med : 16 Pcs.
- 52. Light on Fore Mast : 2 Pcs.
- 53. Light on Bridge : 2 Pcs.
- 54. Capstan Axis : 3Pcs.
- 55. Capstan 1 : 1Pc.
- 56. Capstan 2 : 1Pc.
- 57. Capstan 3 : 2Pcs.
- 58. Capstan 4 : 2Pcs.
- 59. Cart part 1 : 4Pcs.(Ver.2 only)
- 60. Cart part 2 : 4Pcs.(Ver.2 only)

- < Contents >
1. Stained Wooden Deck
 2. Scribed Brass : 220 Pcs.(ver.2) 212Pcs.(ver.1)
 3. Photo Etching : 11 Sheets
 4. Resin Parts : 22 Pcs.
 5. Life Tubes : 25 Pcs.
 6. Dry Transfer : 1 Sheet

<Remove before Applying Wooddeck>

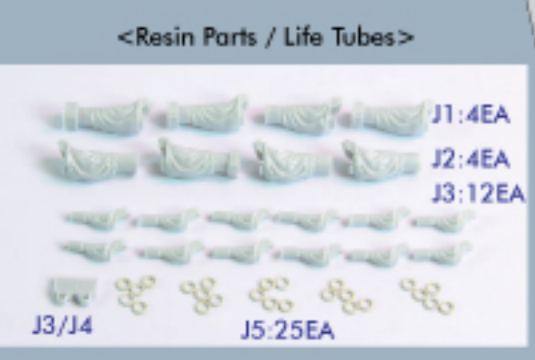
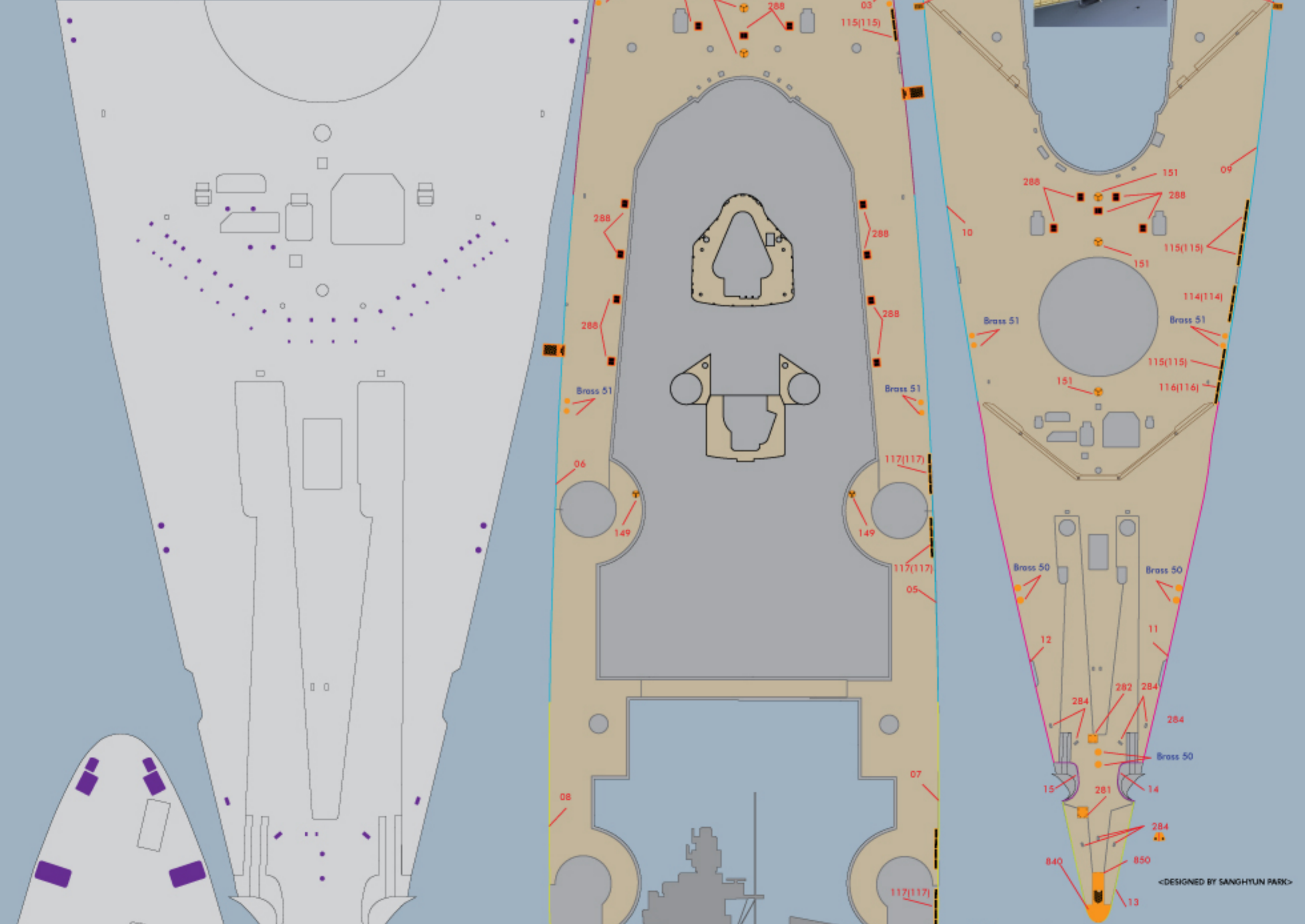

<References>

1. Hans Golly, Bismarck : 1:100 Master Plan, Malsch
2. Josef Kaiser, Schiffsdetail Bismarck - Das Original im Detail, Düsseldorf, SinnerFreiVerlag, 2004
3. Per Philippe Carstedt, Le Cuirasse Bismarck, Outress, Lela Presse, 2003
4. Waldemar Góralski / Grzegorz Nowak The Battleship Bismarck : Super Drawing in 3D, Lublin, Sagora, 2010
5. Mirosław Skwiał, German Naval Guns 1929-1945, Barnsley, Seaforth PubEdVing, 2010
6. Jack Brewer, The Battleship Bismarck : Anatomy of the ship, London, Conway maritime Press, 2005

For better information or corrections, we update this manual on our website.
Periodical review every effort to see to it that our customers are satisfied. If you have product suggestions or if there is a particular product of dry transfer you would like to suggest we carry, please feel free to contact us.

<20mm Single>

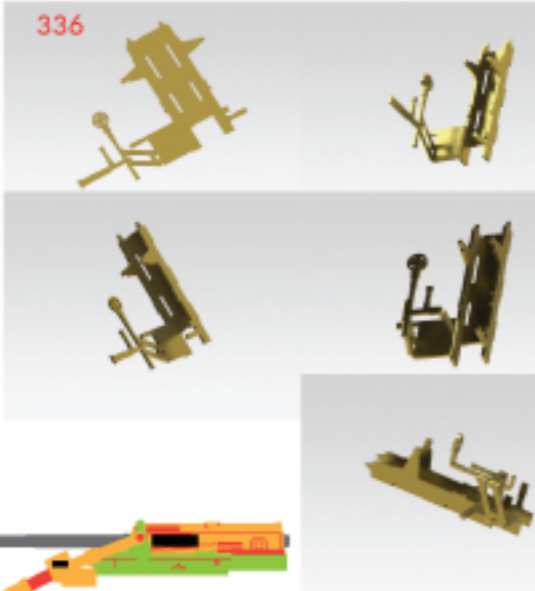
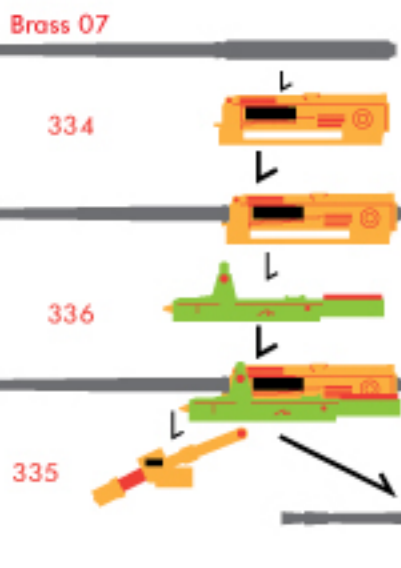
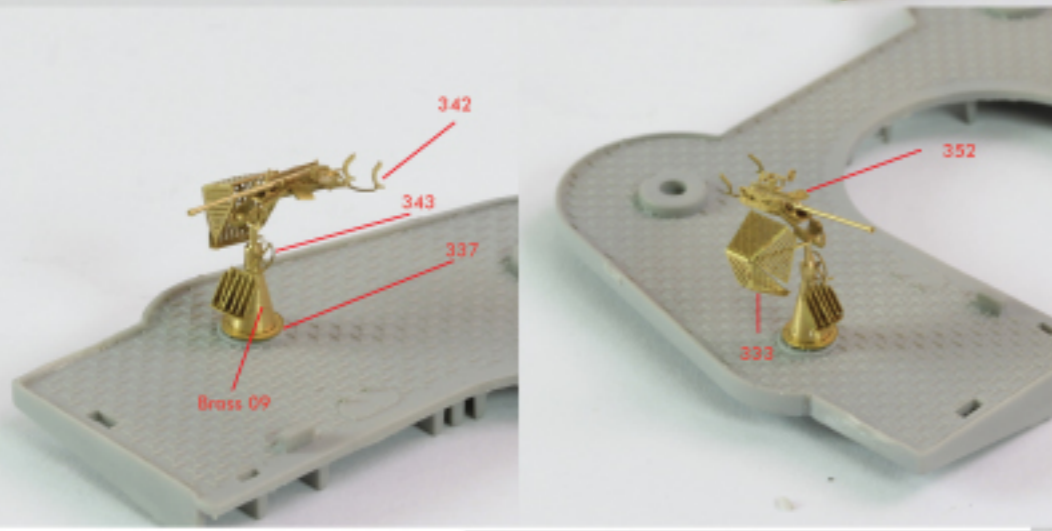

<20mm Flak30>

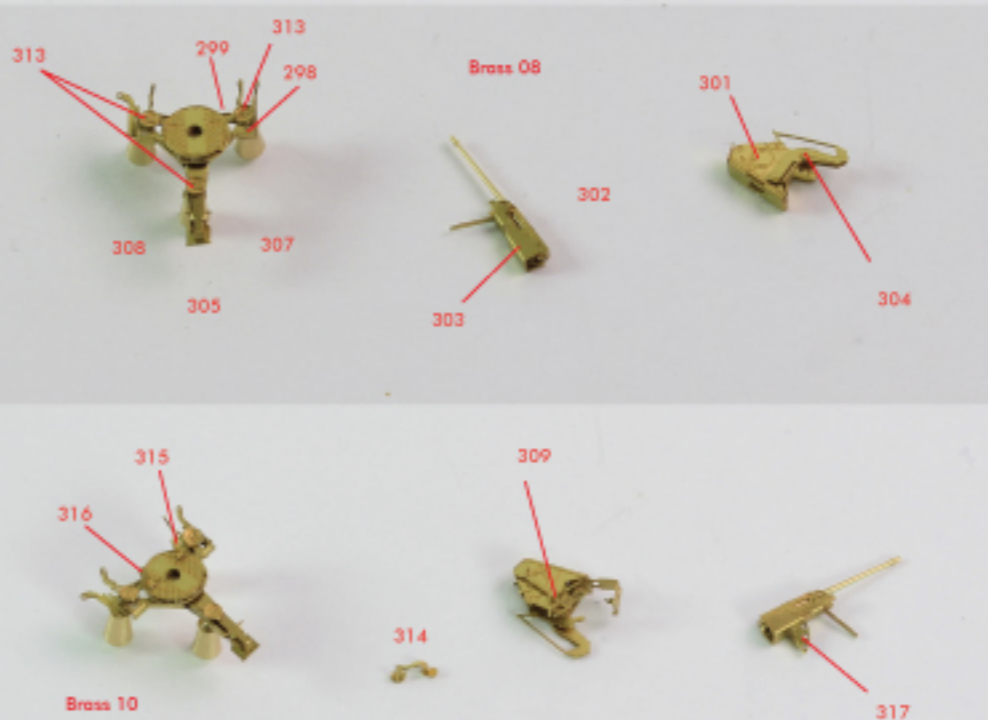
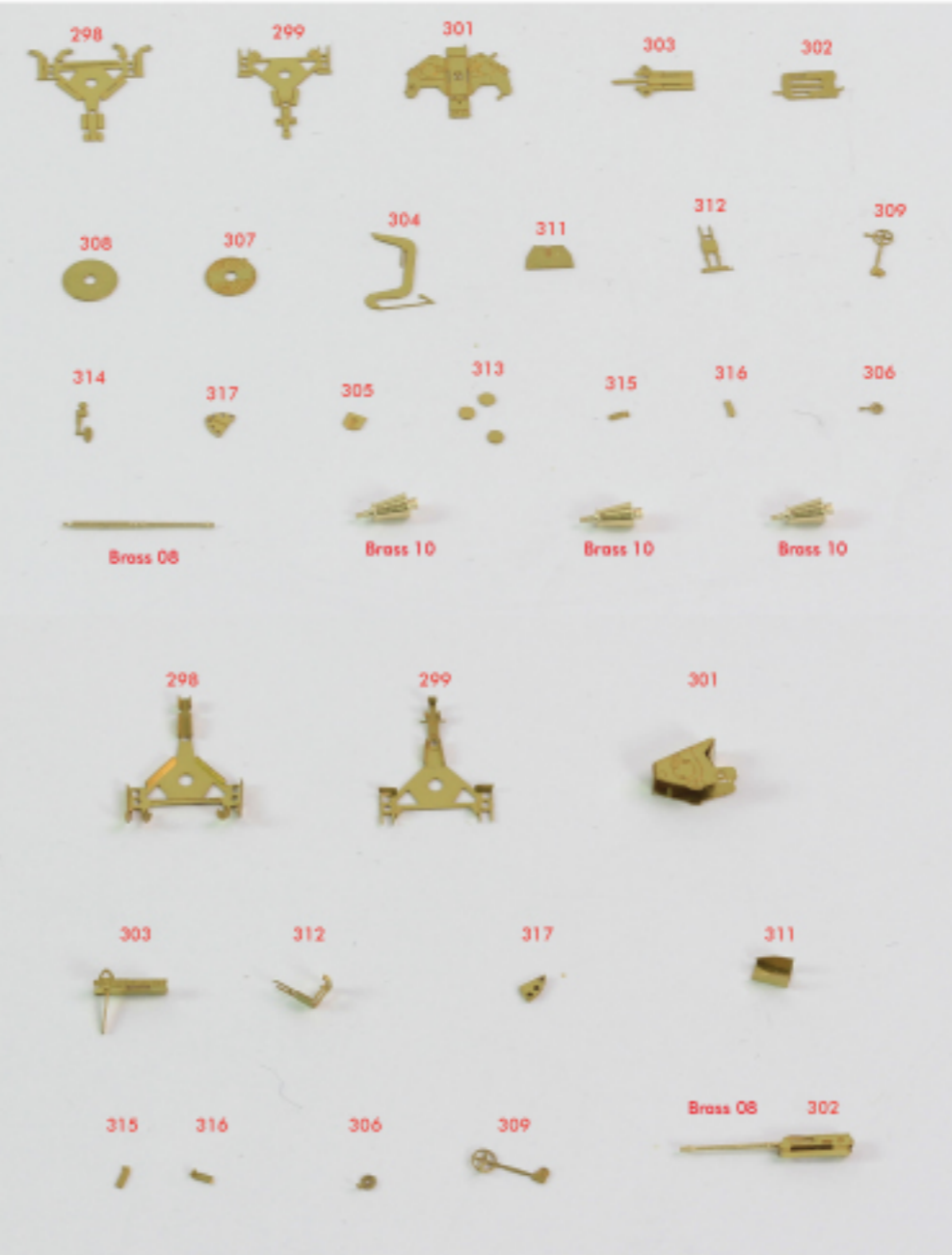

<37mm Gun>

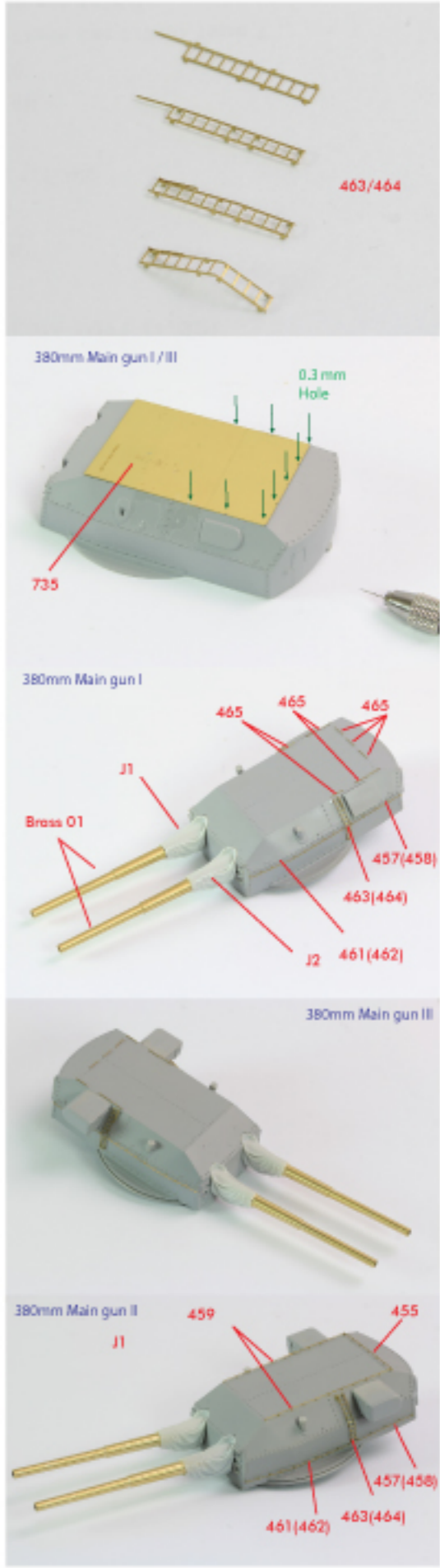

<20mm Quad>



<37mm Gun>

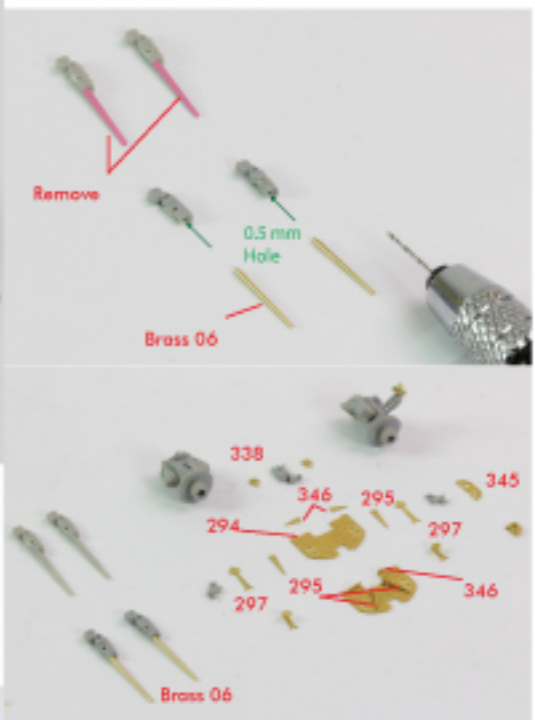

<105mm Gun>

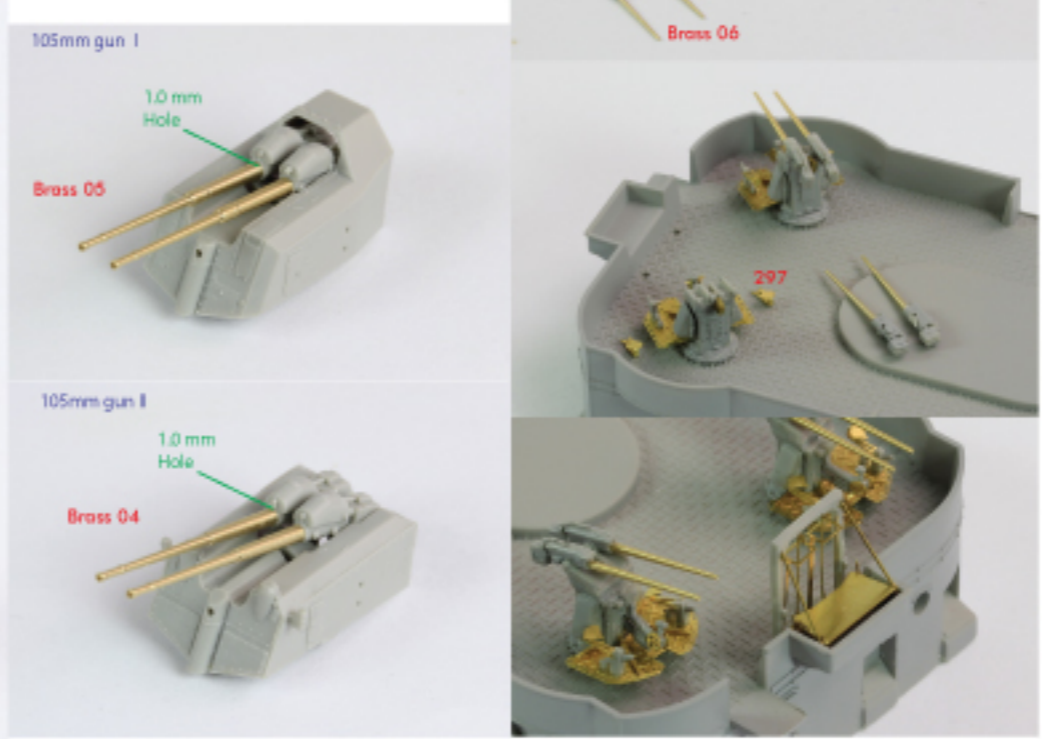

<150mm Sub Gun>

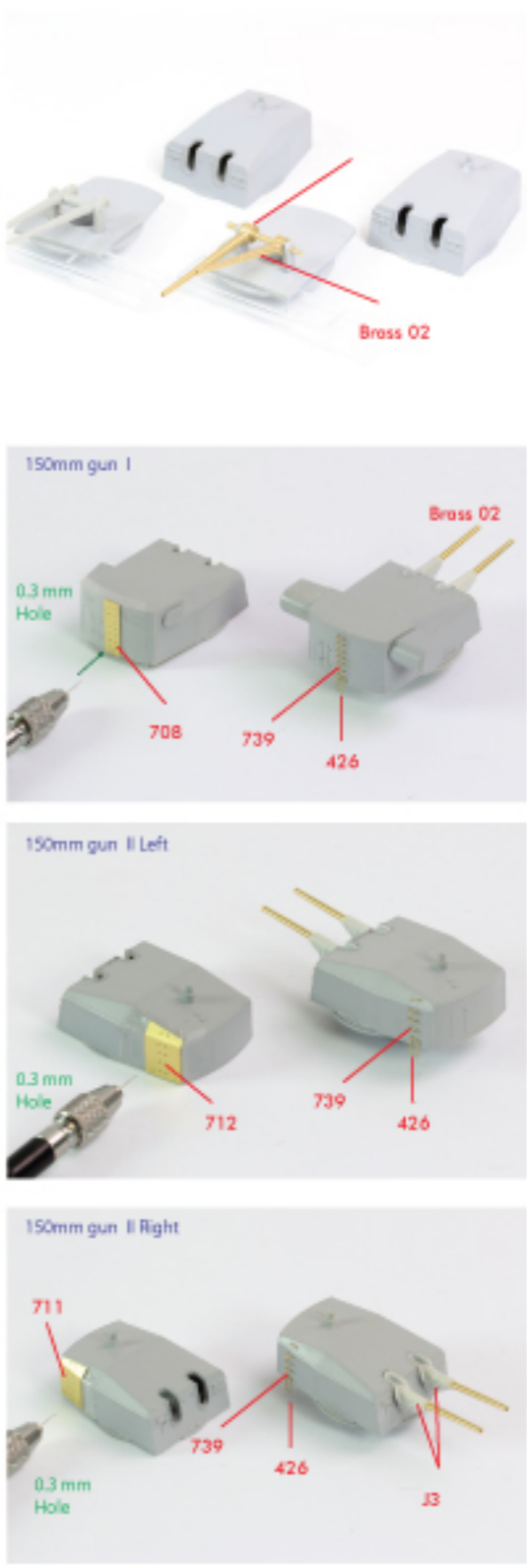

<Staff Stern>

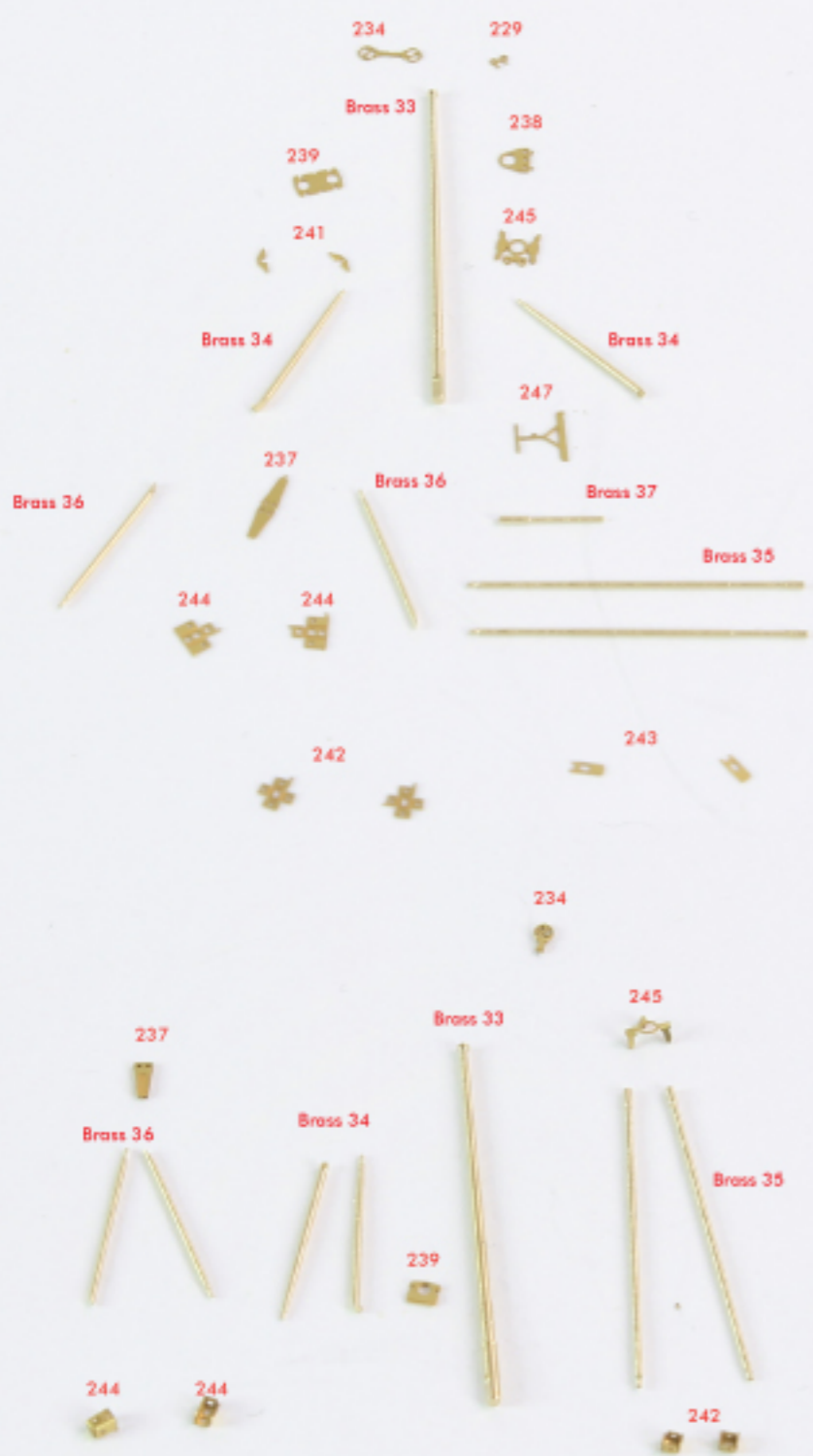

<Staff Bow>



<Ventilator>

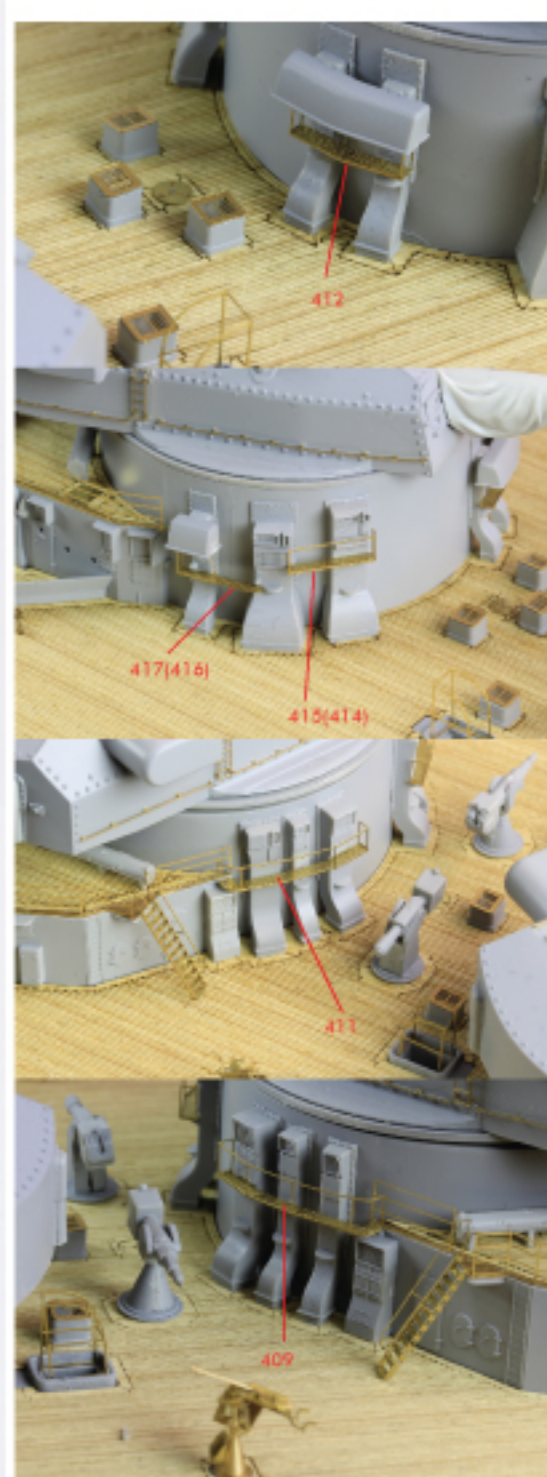
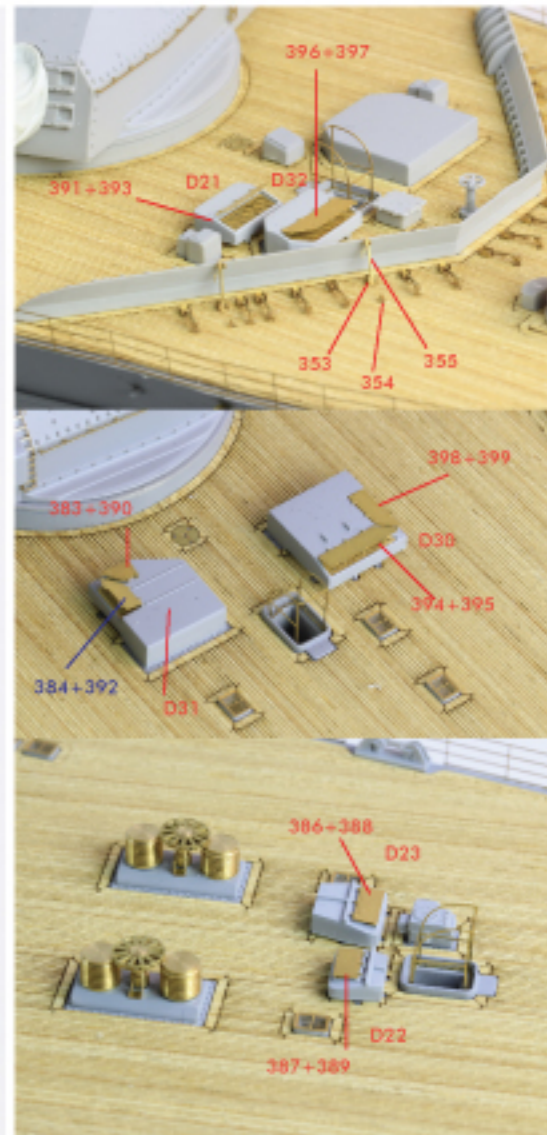

Brass 33

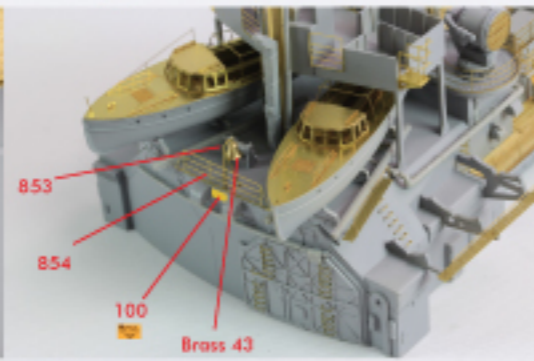
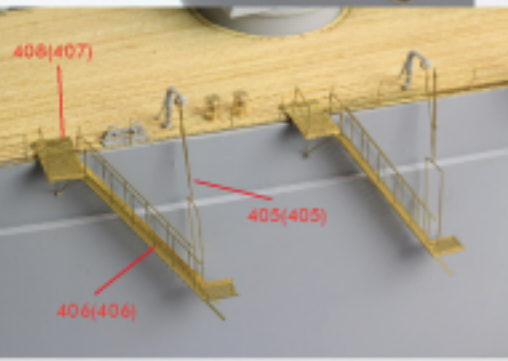
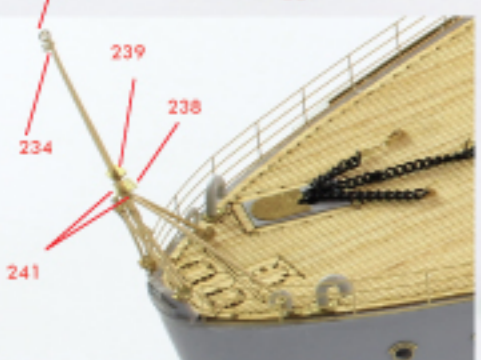
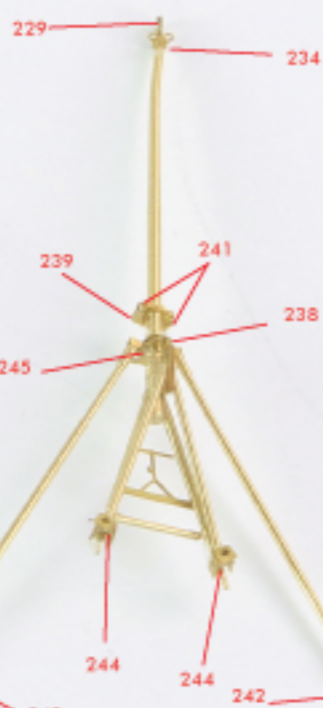

<Turnbuckle for rigging wire and Anchor chains>

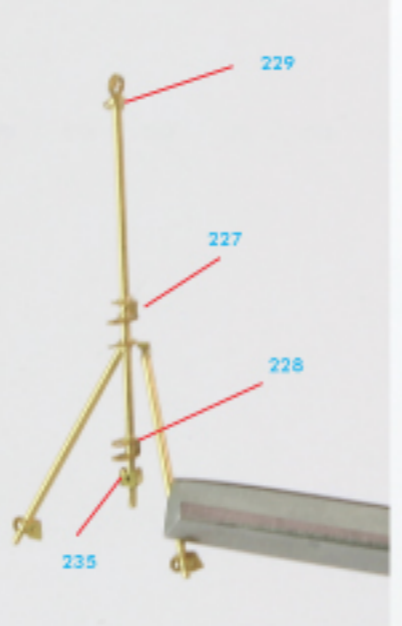

<Capstans>

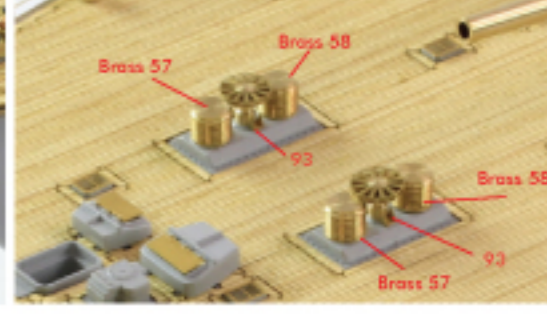
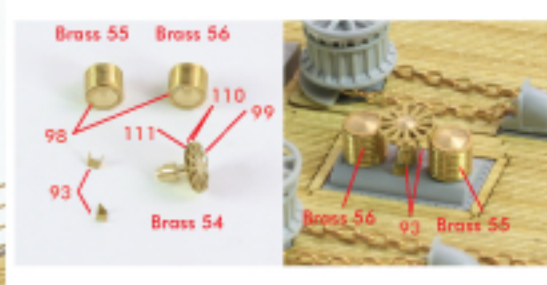

<Swinging Boom & Screw Guard>

<Crane>

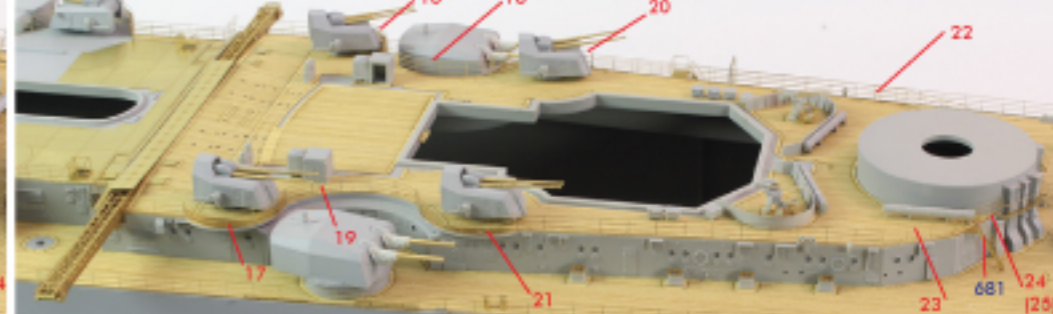
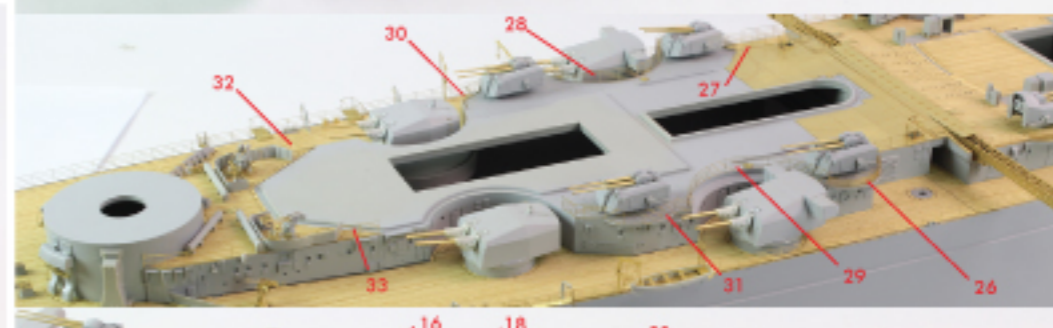
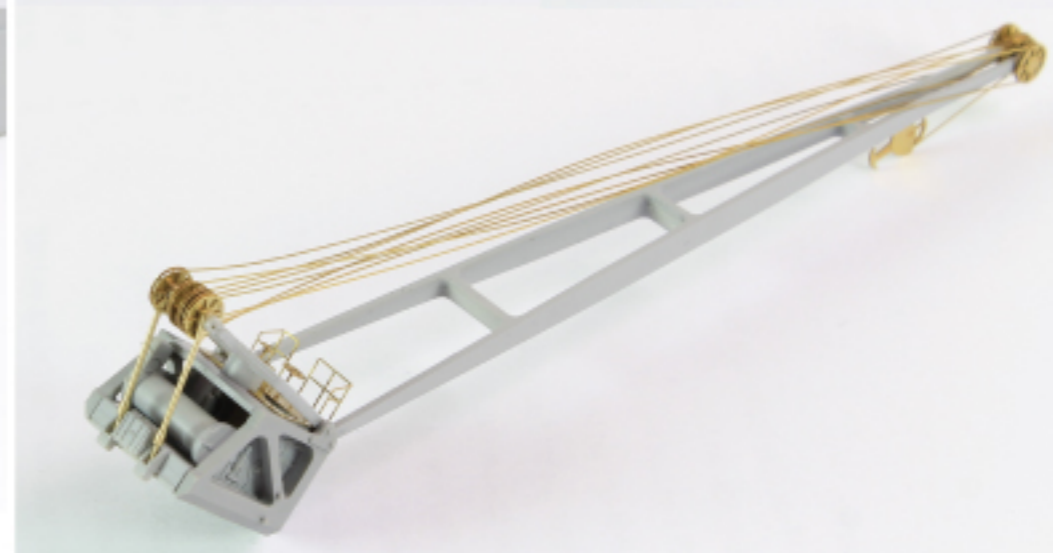
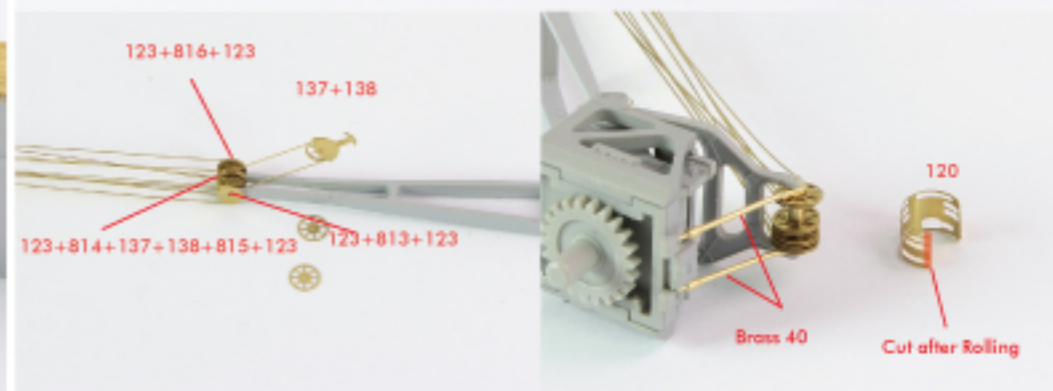
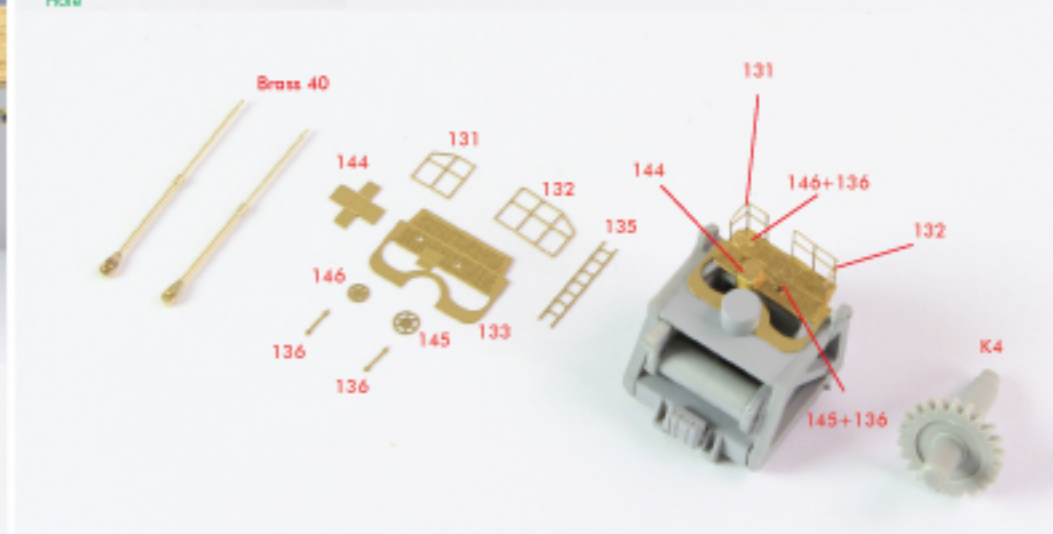
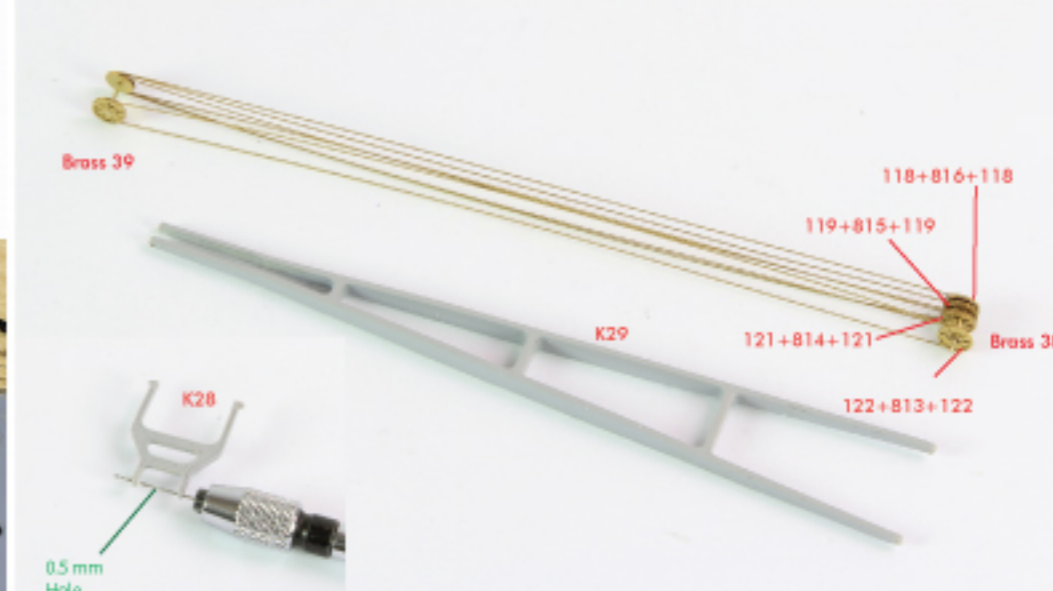
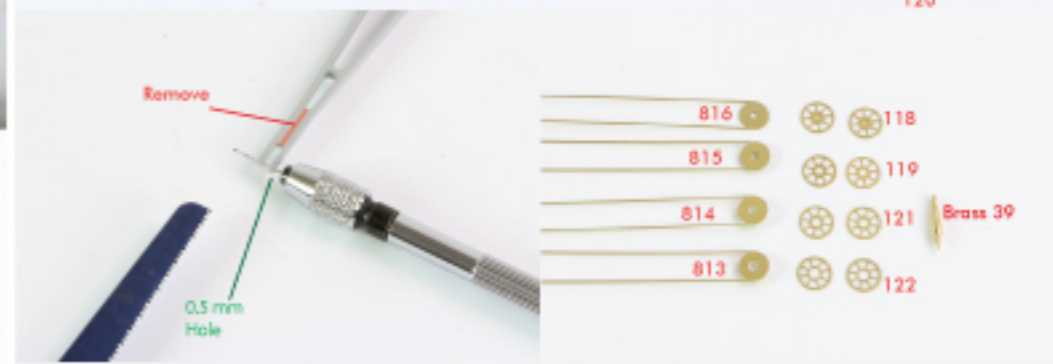
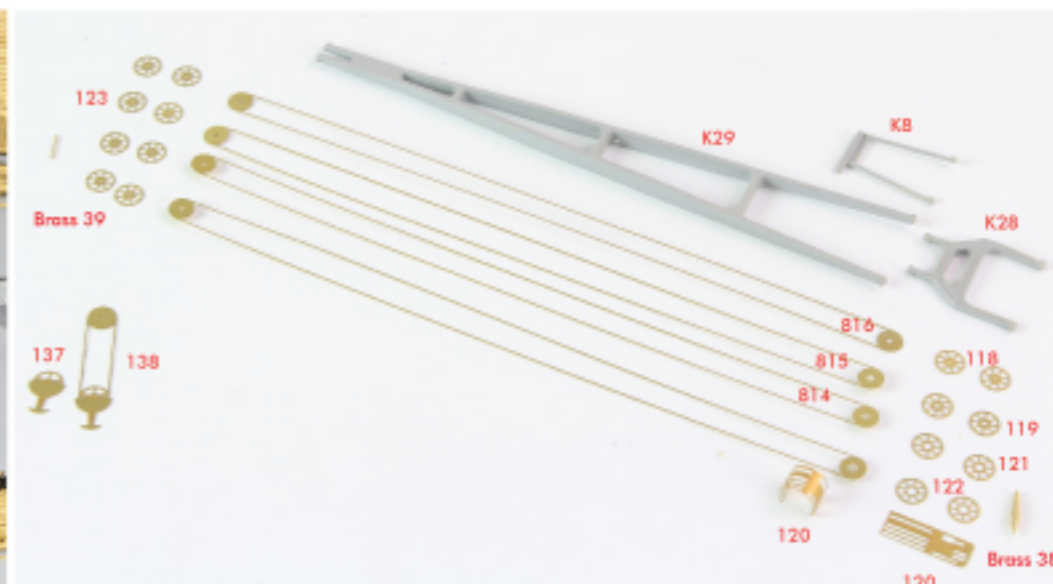
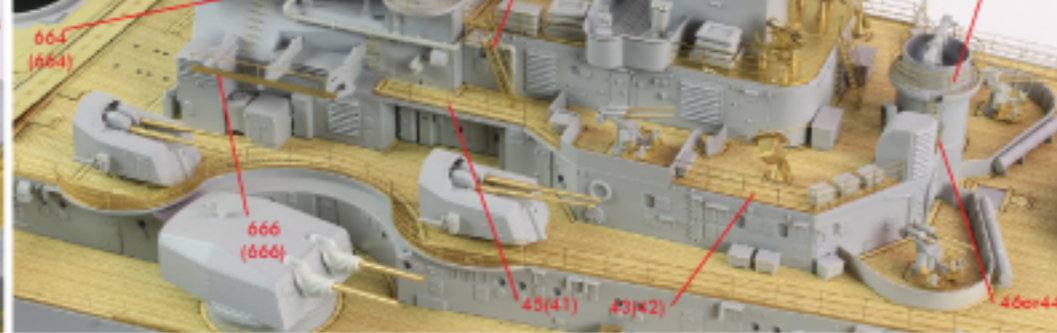
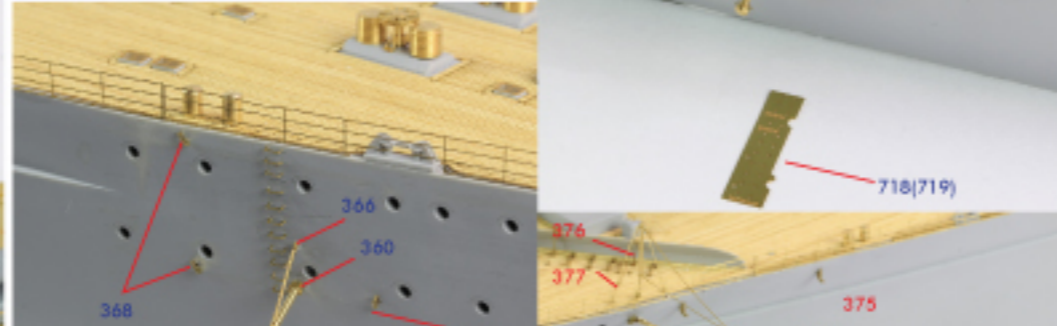
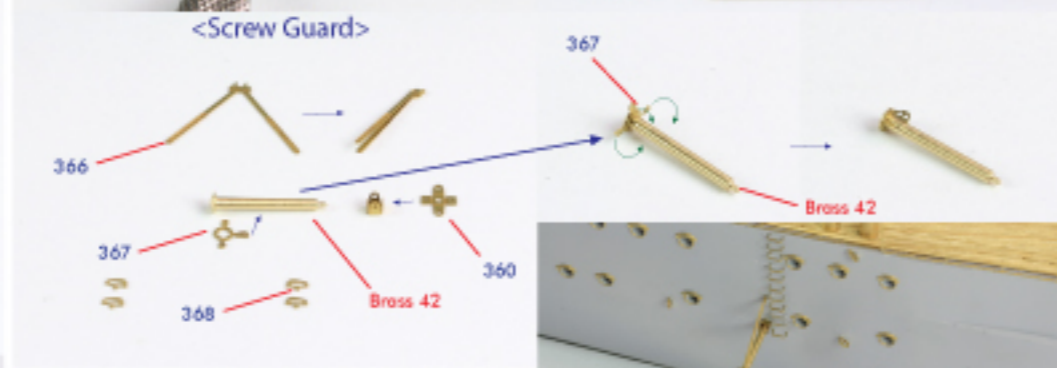
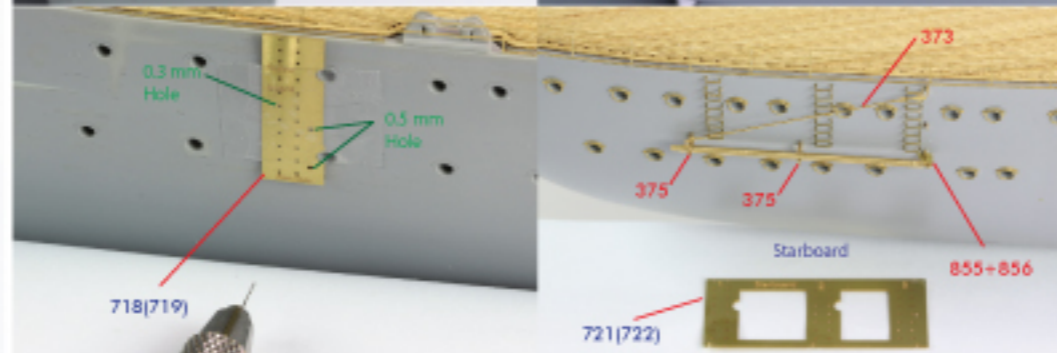
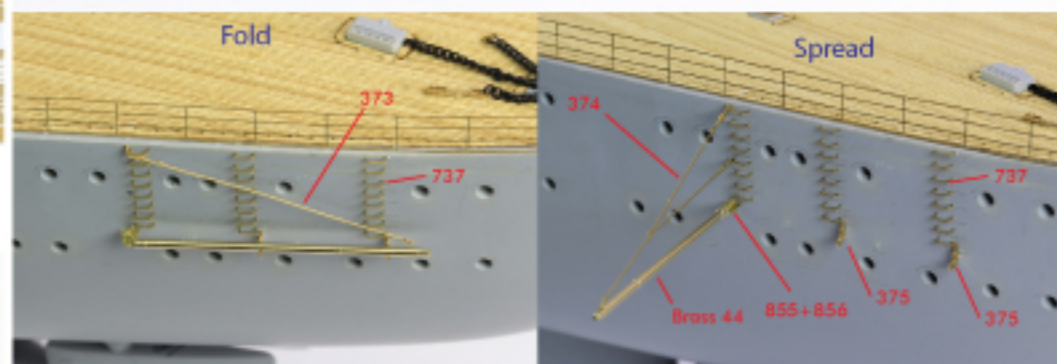
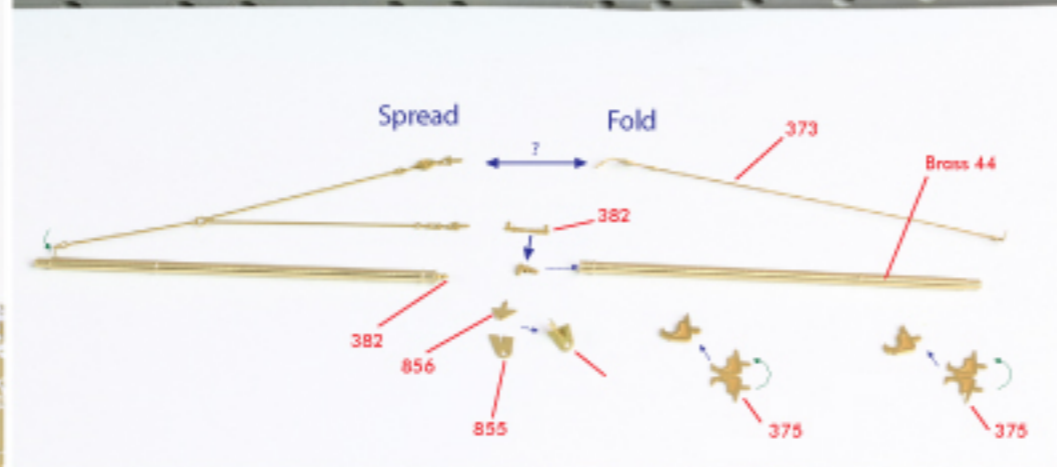
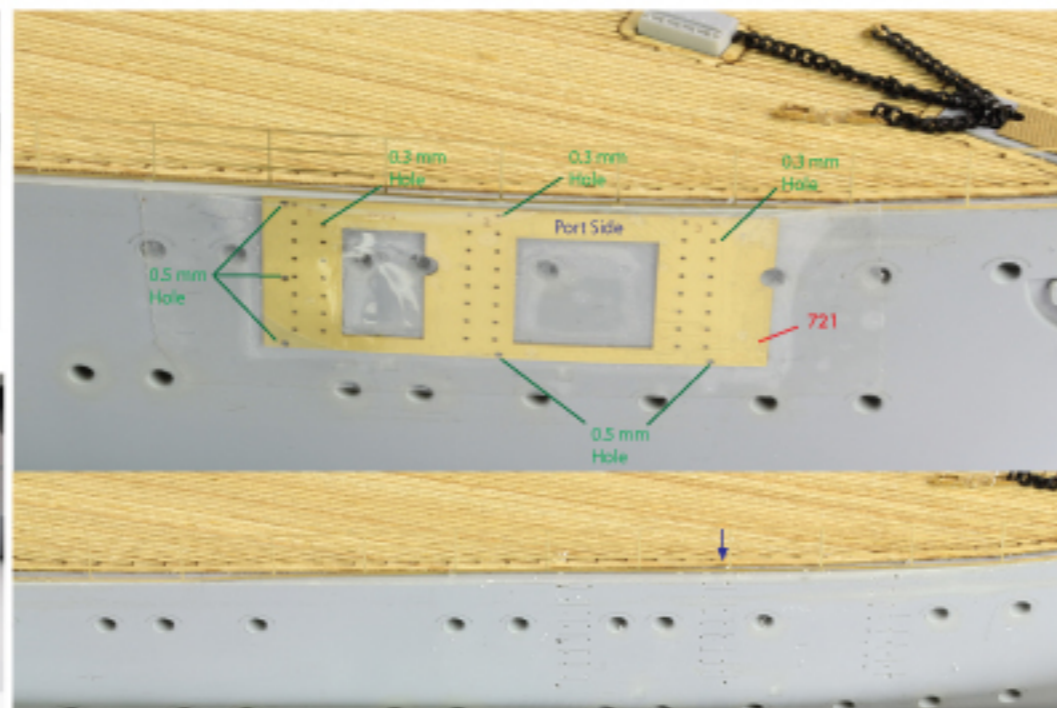
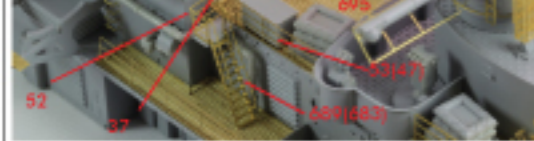
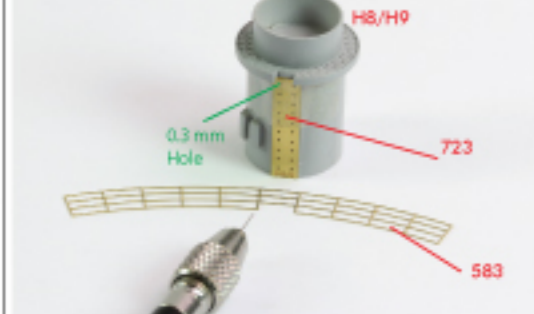
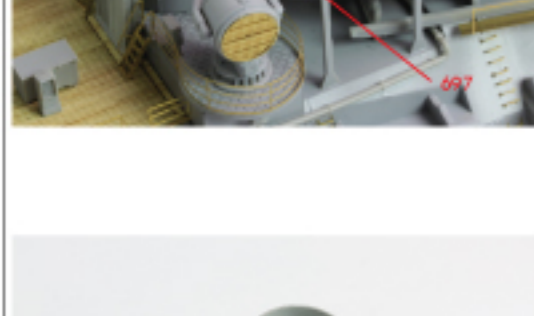
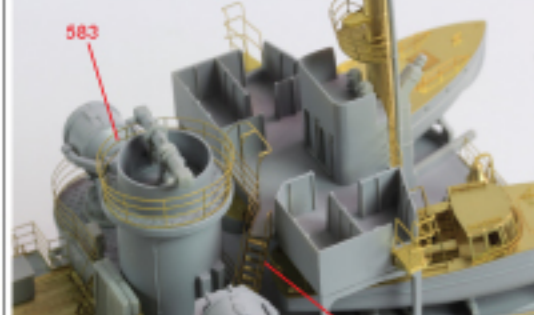
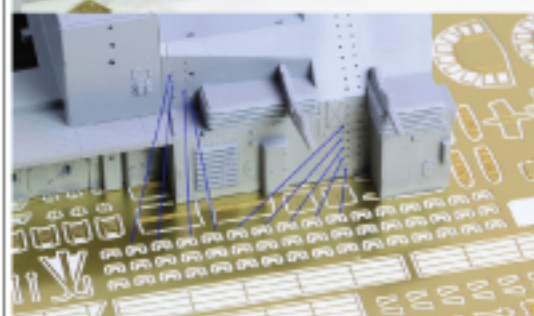
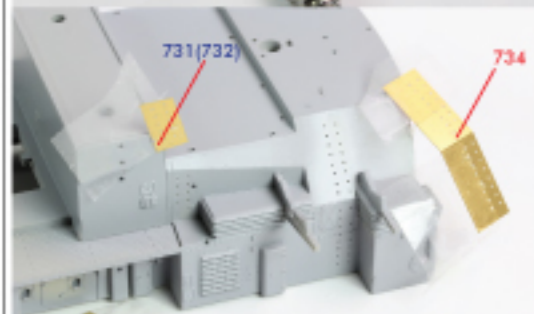
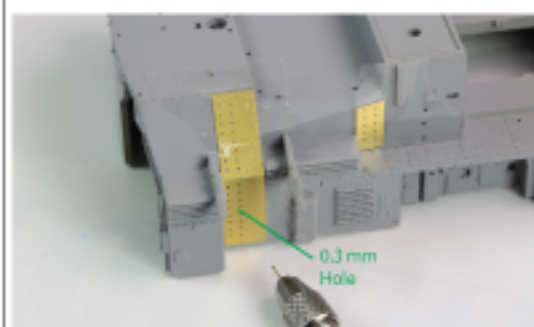
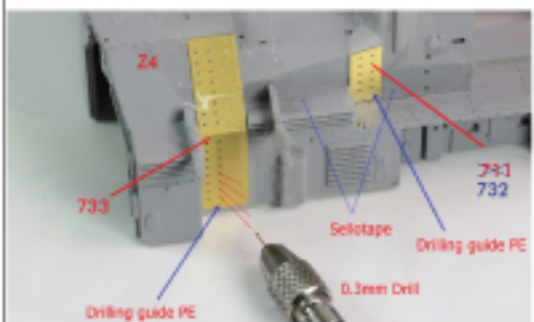

<After Mast>

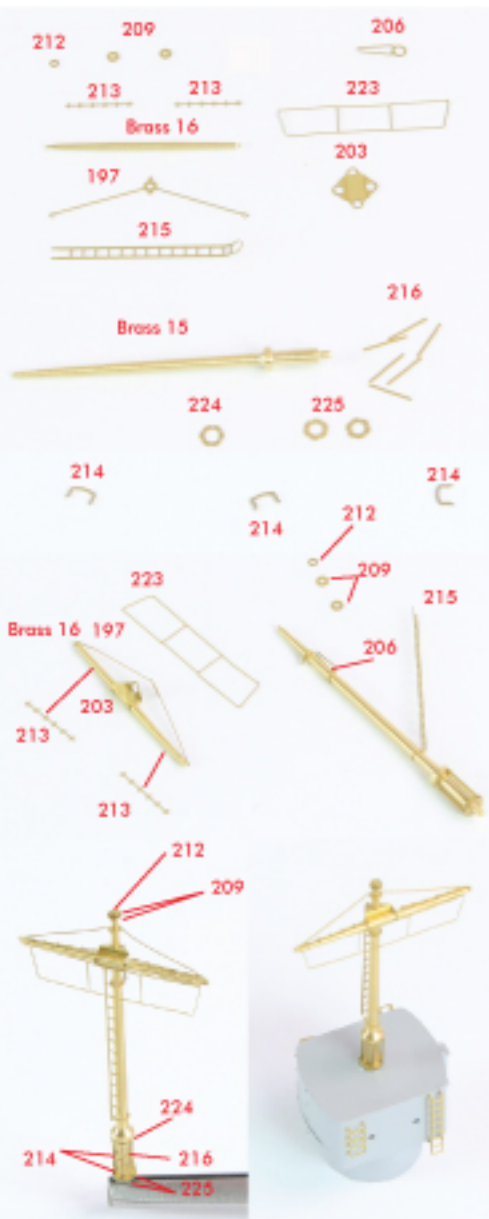

<Main Mast>

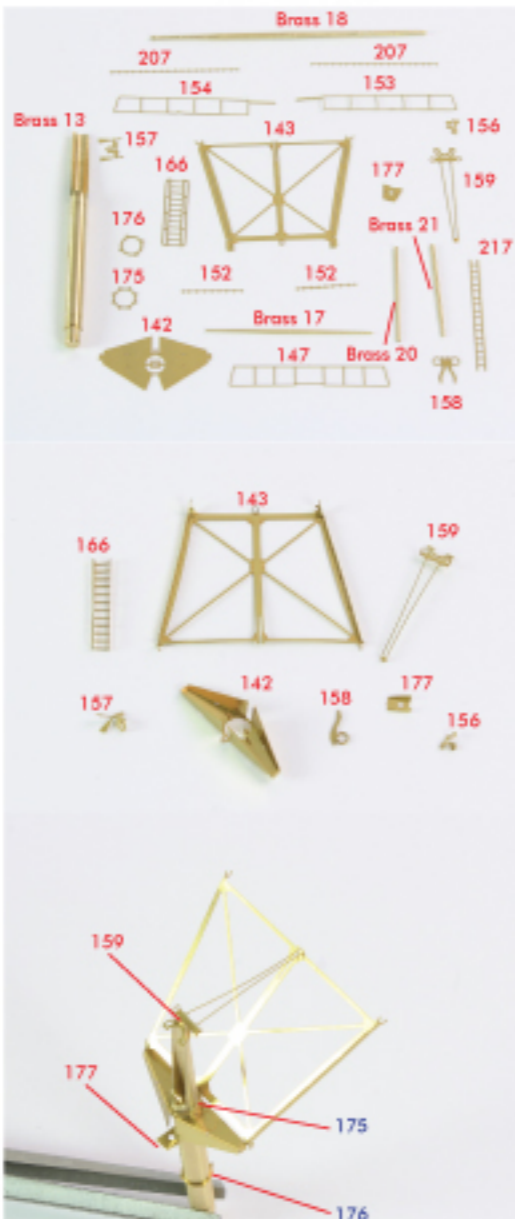

<Fore Mast>

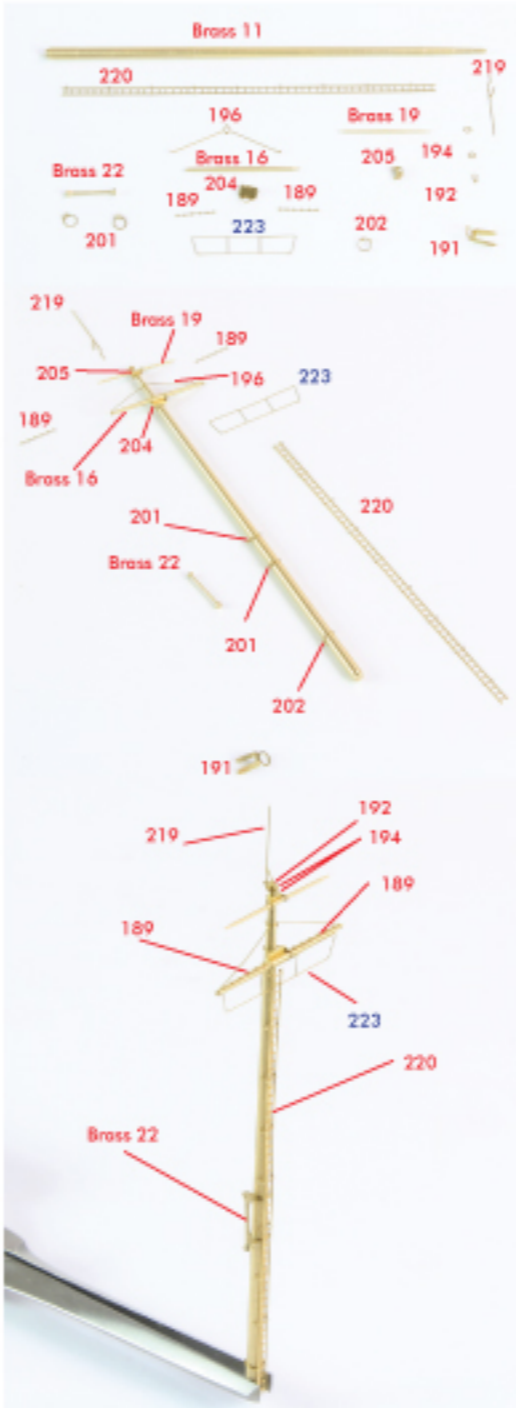

<Funnel>

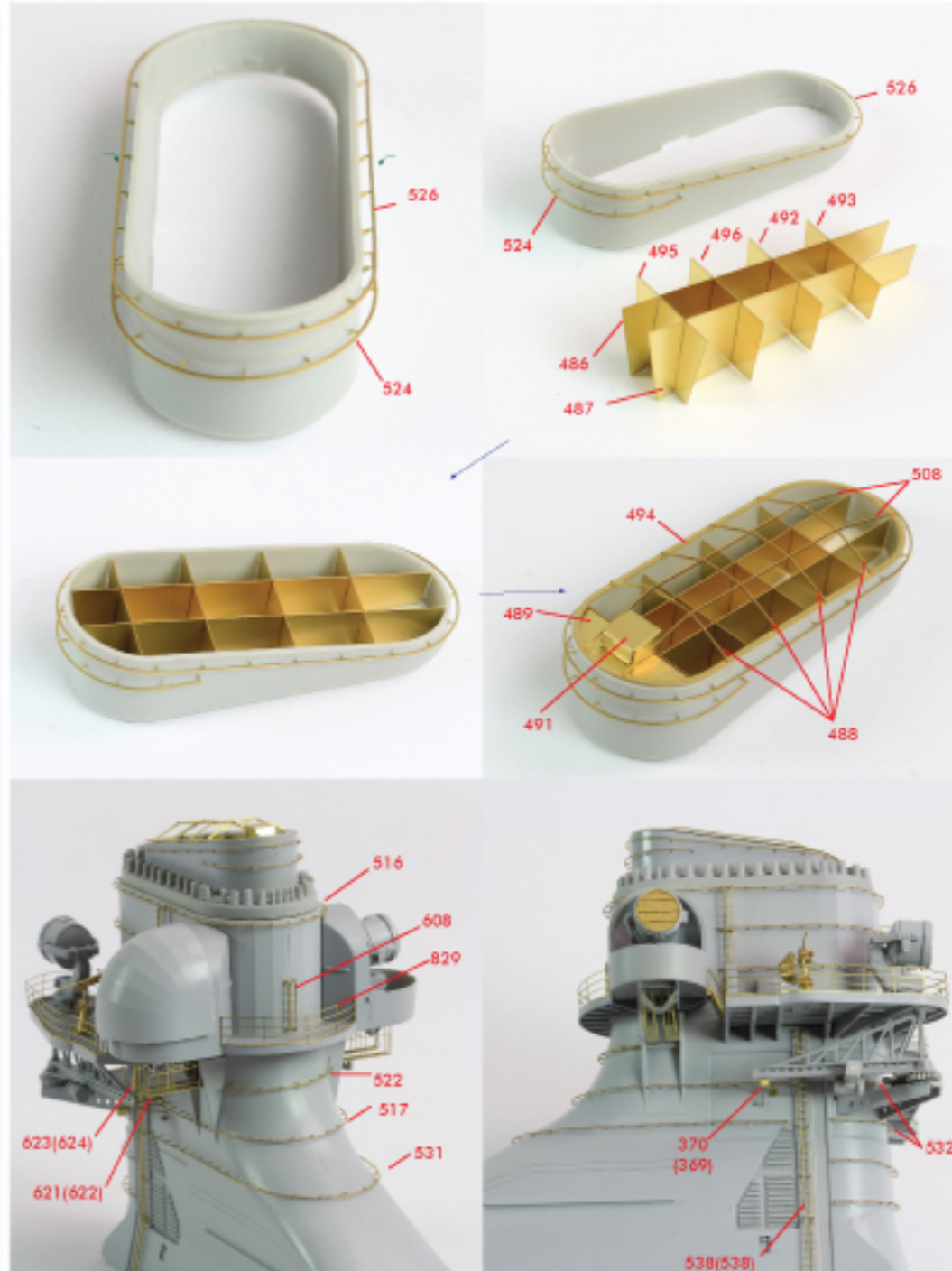

<Main Top Mast>

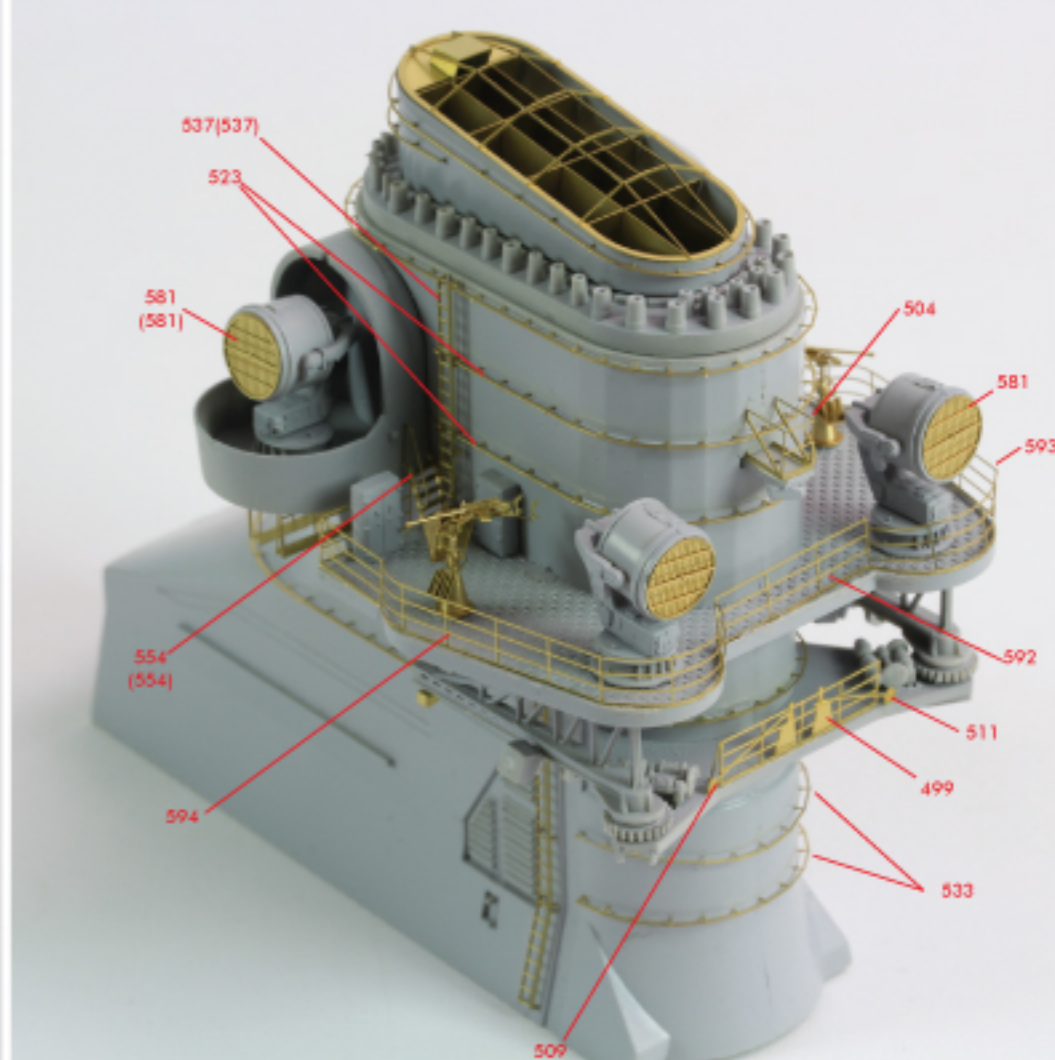
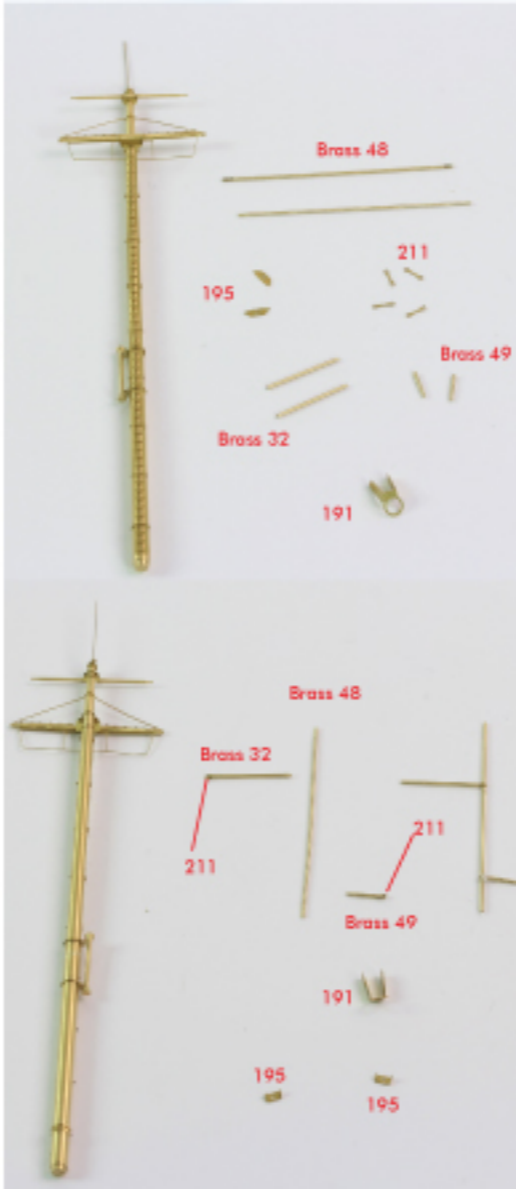
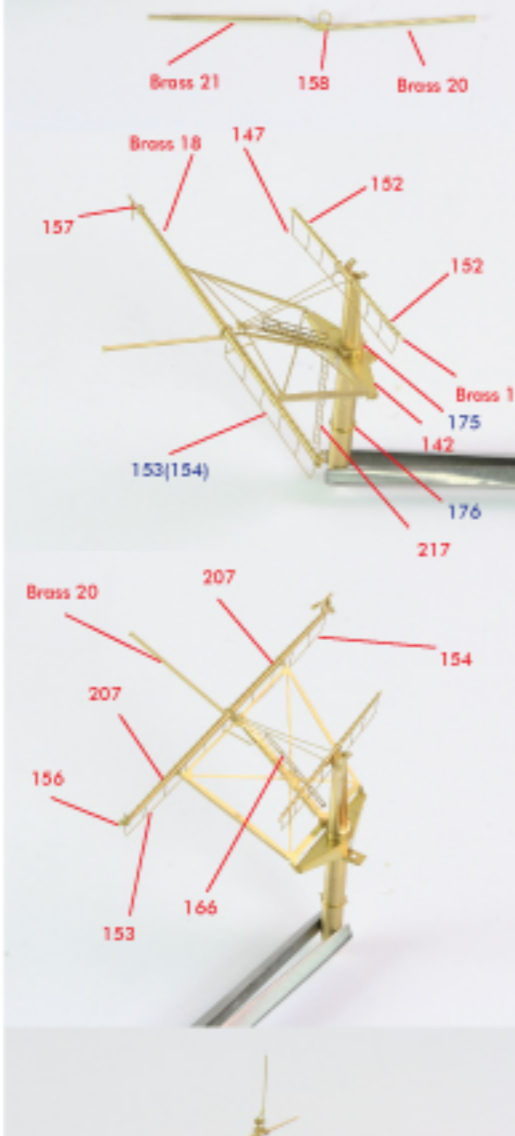
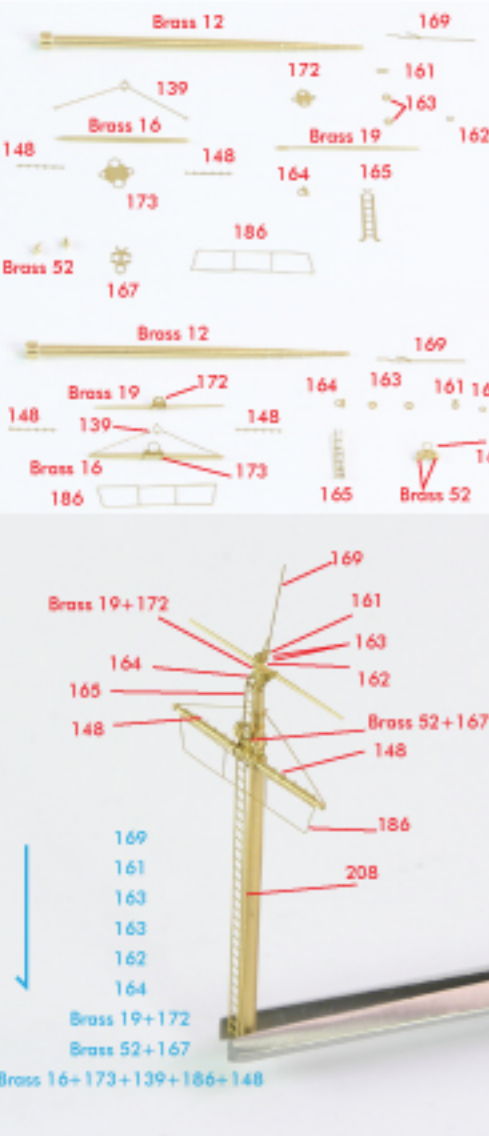

<Main Mast Base>

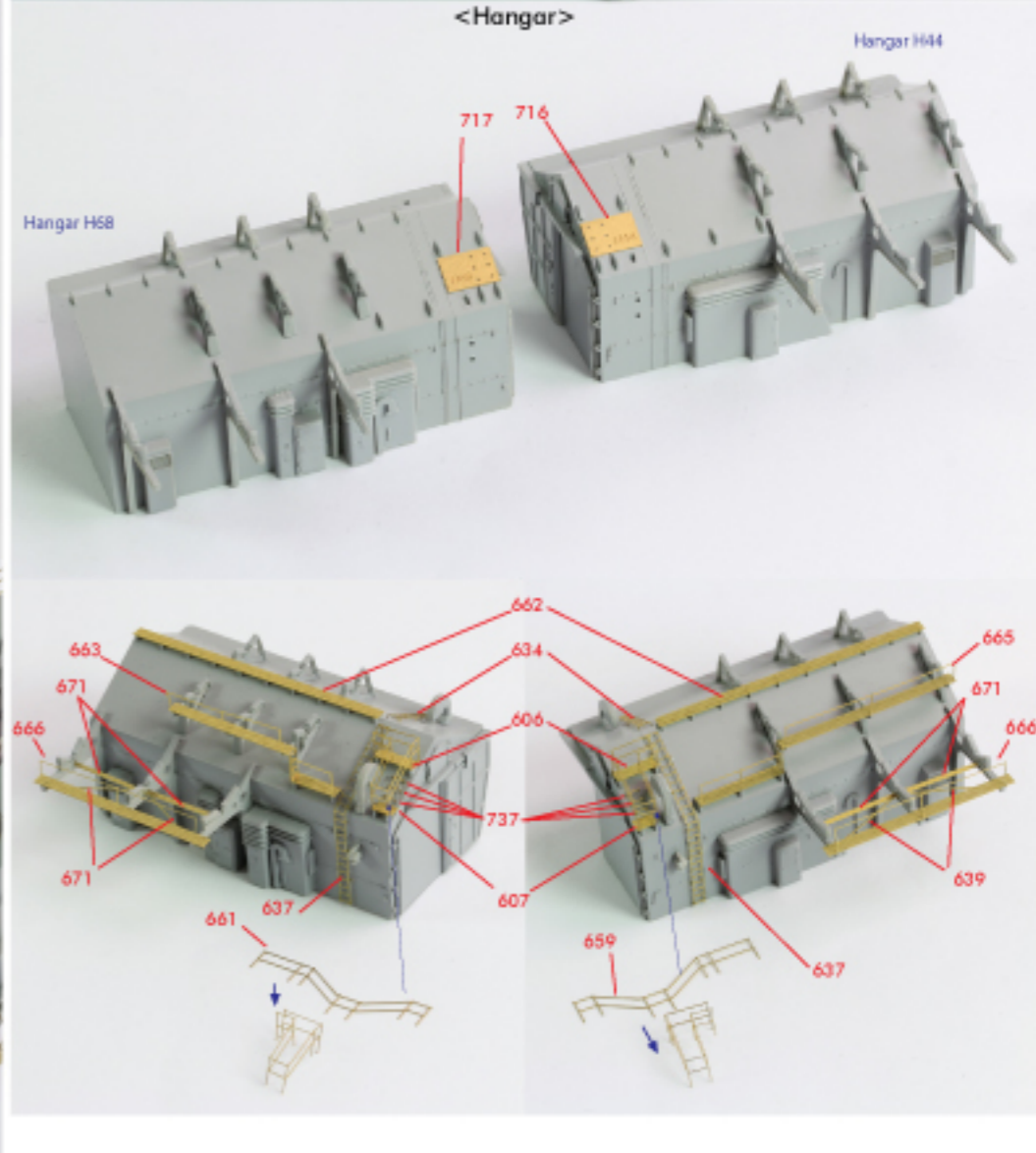
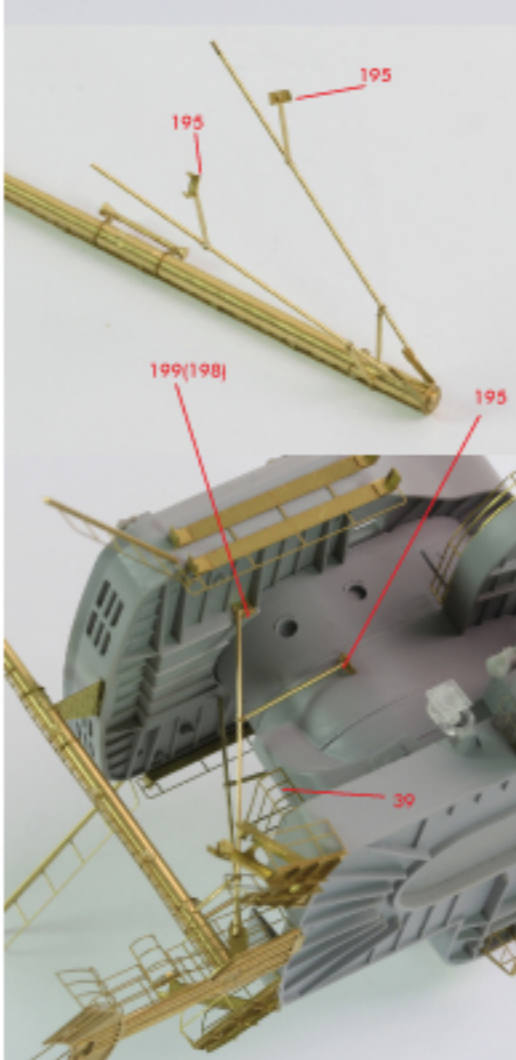
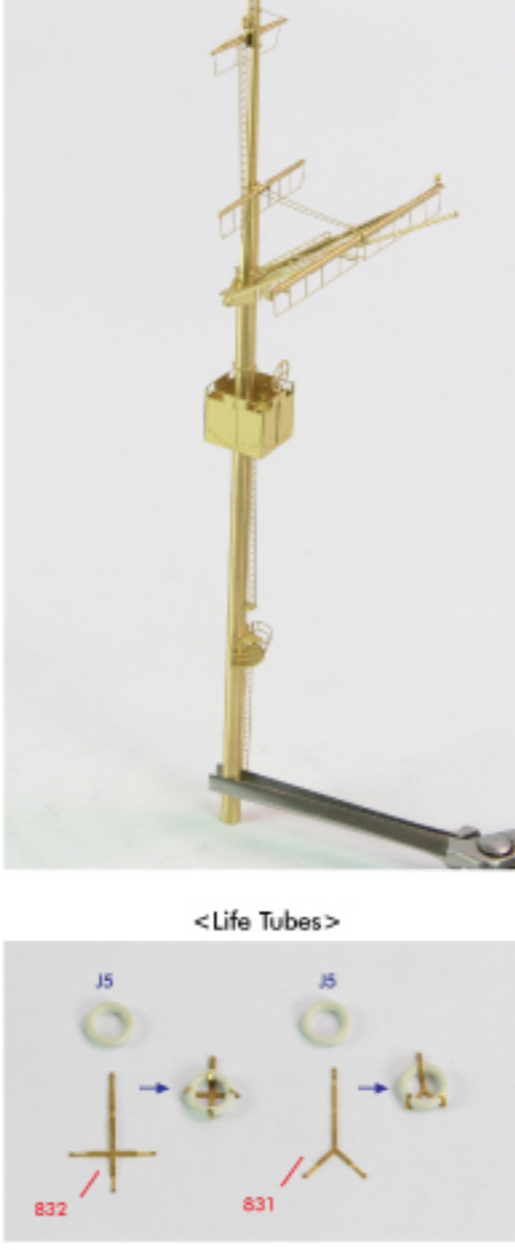
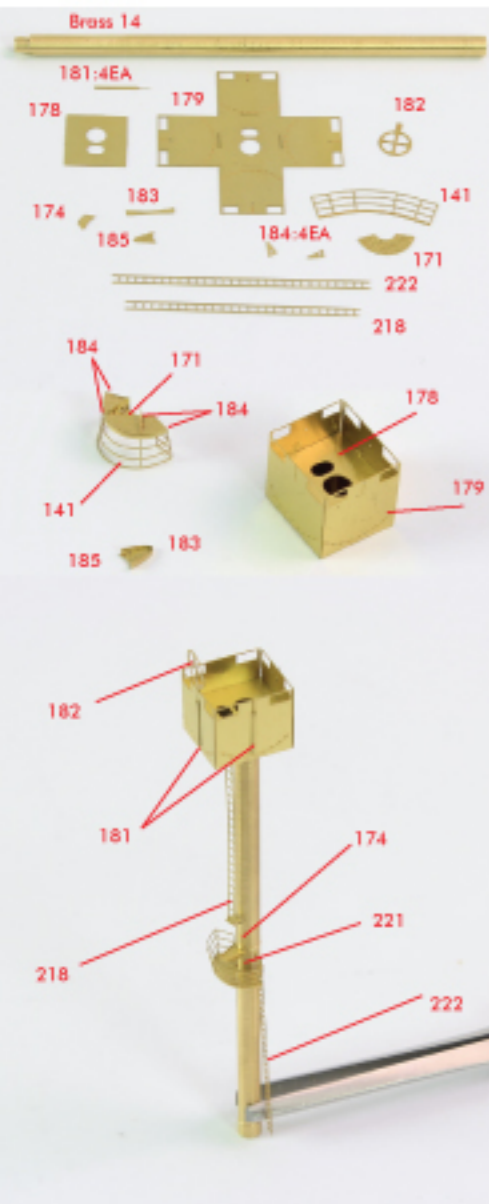

<Wing Bridge>

