



He 111H-3 ВВС Румынии Бомбардировщик II MB

В начале 30-х годов в мире возникла идея создания скоростного бомбардировщика, который мог бы обогнать современные ему истребители-бипланы. Одним из воплощений этой концепции стал двухмоторный бомбардировщик He 111, разработанный германской фирмой Хейнкель Флюгzeugwerke.

С ноября 1940 г. началось производство самолетов He 111H-3 с усиленным вооружением, на которых были установлены двигатели жидкостного охлаждения Jumo 211D-1 увеличенной мощности.

В начале 1940 г. было построено 504 бомбардировщика He 111H-3. Часть из них получили ВВС Румынии.

Тактико-технические характеристики He 111H-3 ВВС Румынии

Длина, м.....	16,38
Размах крыла, м.....	22,50
Взлетный вес, кг.....	13300
Двигатели.....	2xJumo 211D-1, 1200 л.с.
Максимальная скорость, км/ч.....	430
Потолок, м.....	8000
Дальность, км.....	2000
Вооружение.....	3-4x7,92-мм пулемета MG 15, до 2000 кг бомб

ВНИМАНИЕ!

Перед сборкой внимательно прочитать руководство по монтажу. Каждая деталь пронумерована. Соблюдать последовательность монтажа. Необходимые рабочие инструменты: нож и напильник для зачистки деталей; резиновая лента, клейкая лента и зажимы для сушки белья для прижимания склеиваемых деталей. Детали из пластика очистить в растворе мягкого моющего средства и высушить на воздухе для того, чтобы краска и переводные картинки лучше прилипали. Перед приклеиванием проверить, подходят ли детали; клей наносить экономно. Хром и краску удалить с поверхности склеивания. Небольшие детали покрасить перед тем, как они будут удалены из рамок. Краску необходимо хорошо просушить, только после этого продолжать сборку. Каждую соответствующую переводную картинку отдельно вырезать и примерно на 20 секунд окунуть в теплую воду. На обозначенном месте картинку отделить от бумаги и прижать промокающей бумагой.

He 111H-3 Romanian AF WWII Bomber

In the beginning of 30s it was appeared in the world an idea of high-speed bomber that could outstrip contemporary fighters. One of the objectifications of this conception became the twin-engine bomber He 111 designed by a German Heinkel Flugzeugwerke AG company.

Since the November of 1939 it were produced He 111H-3 planes with liquid-cooled Jumo 211D-1 engines of increased power and more powerful armament.

In early 1940 it were produced 504 He 111H-3 bombers. Some were delivered to the Romanian Air Force.

Tactical and Technical Specifications of He 111H-3 Romanian AF

Length, m.....	16,38
Span, m.....	22,50
Start weight, kg.....	13300
Engines.....	2xJumo 211D-1, 1200 hp
Max. Speed, km/h.....	430
Service ceiling, m.....	8000
Range, km.....	2000
Armament.....	3-4x7,92 mm MG 15, bomb load - up to 2000 kg

CAUTION!

Read the instructions thoroughly prior to assembly. Each component is numbered. Adhere to specified sequence of assembly. Tools required: knife and file for removal of components from frame; rubber bond, adhesive tape and clothes pegs for clamping components together after applying adhesive. Clean plastic components in a mild detergent solution and allow to air-dry so that paint and transfers adhere better. Prior to applying adhesive, check to see whether the components fit together; apply adhesive sparingly. Remove chrome and paint from the contact surfaces. Paint small components before removing them from the frame. Allow paint to dry well, and only then continue to assemble. Cut out each transfer individually and immerse in warm water for approx. 20 seconds. Slide transfer off paper and into designated position, then press on with blotting paper.

ИСПОЛЬЗУЕМЫЕ КРАСКИ / USED COLORS:

	Revell	Tamiya		
A	108	XF1	Черный, матовый	Flat Black
B	105	XF2	Белый, матовый	Flat White
C	312	X8	Светло-желтый, матовый	Light Yellow
D	140	XF27	Черно-зеленый RLM 70	Schwarzgrun RLM70
E	139	XF61	Темно-зеленый RLM62	Dunkelgrun RLM62
F	149	XF23	Голубой RLM65	Hellblau RLM65
G	177	XF84	Черно-серый, матовый	Schwarzgrau RLM66
H	145	XF22	Серо-зеленый RLM02	Grau RLM02
J	199	XF16	Алюминий, полуматовый	Aluminium

	Revell	Tamiya		
K	191	X11	Сталь	Steel
L	109	X10	Темный металл	Gun Metal
M	183	XF64	Ржавчина	Rust
N	731	X27	Красный, прозрачный	Clear Red
P	161	X25	Зеленый, прозрачный	Clear Green
Q	185	XF10	Коричневый RLM61	Dunkelbraun RLM61
R	175	XF20	Серый RLM63	Grau RLM 63
S	330	XF7	Красный, матовый	Flat Red

01 СТАДИЯ СБОРКИ
ASSEMBLY STEP

A ИСПОЛЬЗУЕМАЯ КРАСКА
USED COLOR

***** СДЕЛАТЬ САМОМУ
SCRATCH BUILD

⚠ ПРОСВЕРЛИТЬ
OPEN HOLE

03 СБОРОЧНАЯ ЕДИНИЦА
ASSEMBLY UNIT

? ПРОИЗВОЛЬНЫЙ ВЫБОР
OPTIONAL

x2 СДЕЛАТЬ ДВЕ ДЕТАЛИ
MAKE 2 PCS

⚠ НЕ КЛЕИТЬ
DO NOT CEMENT

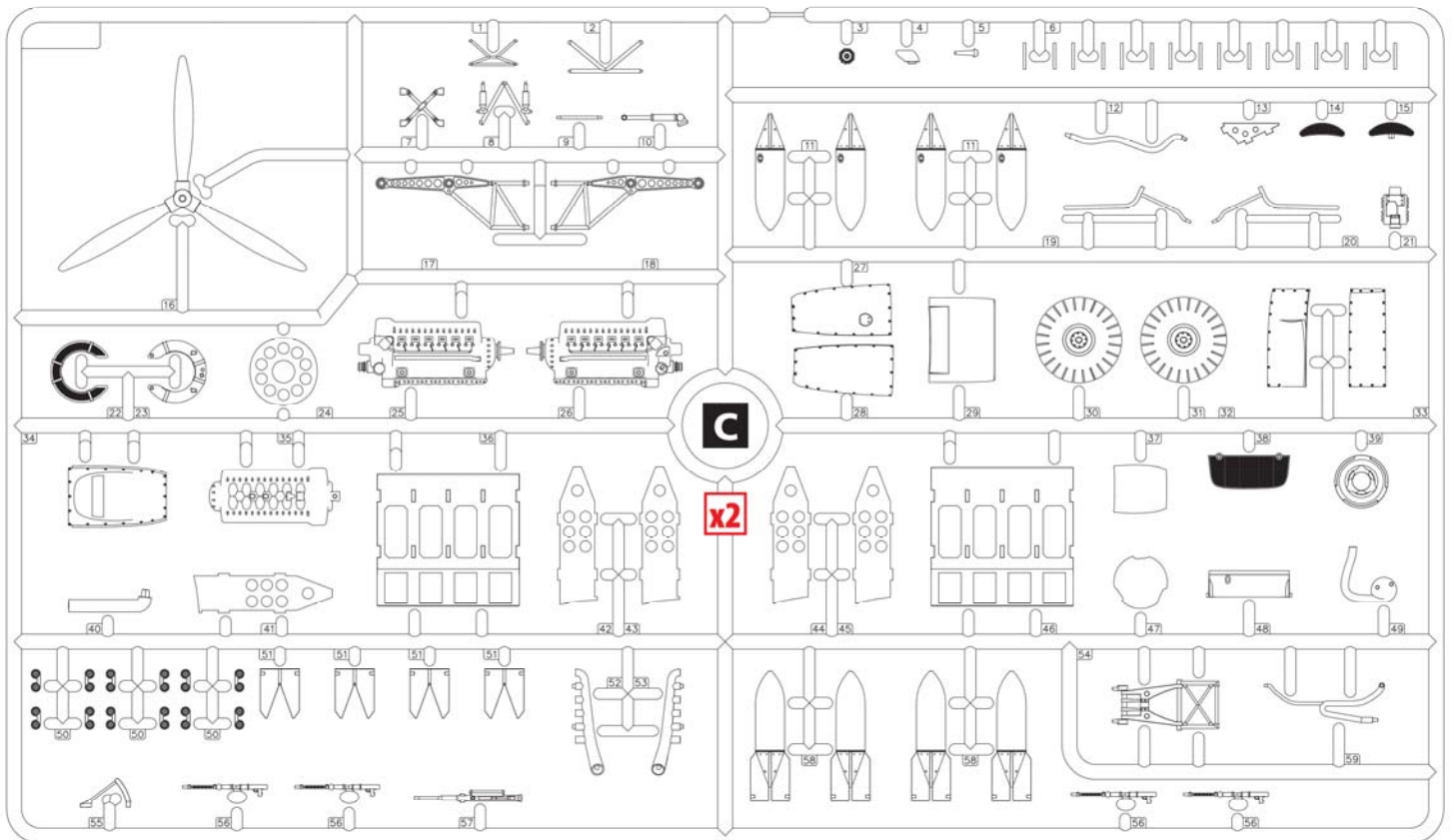
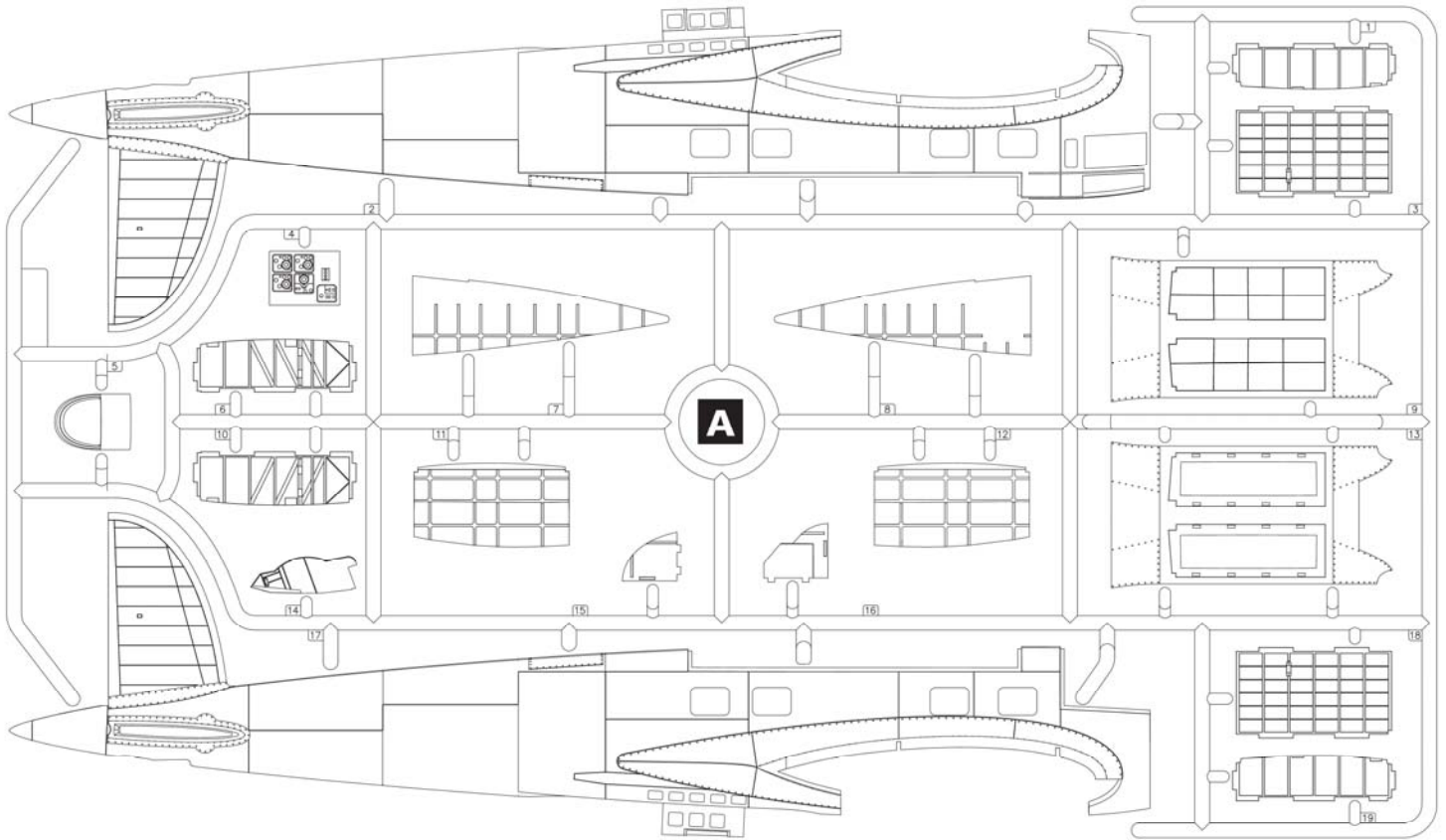

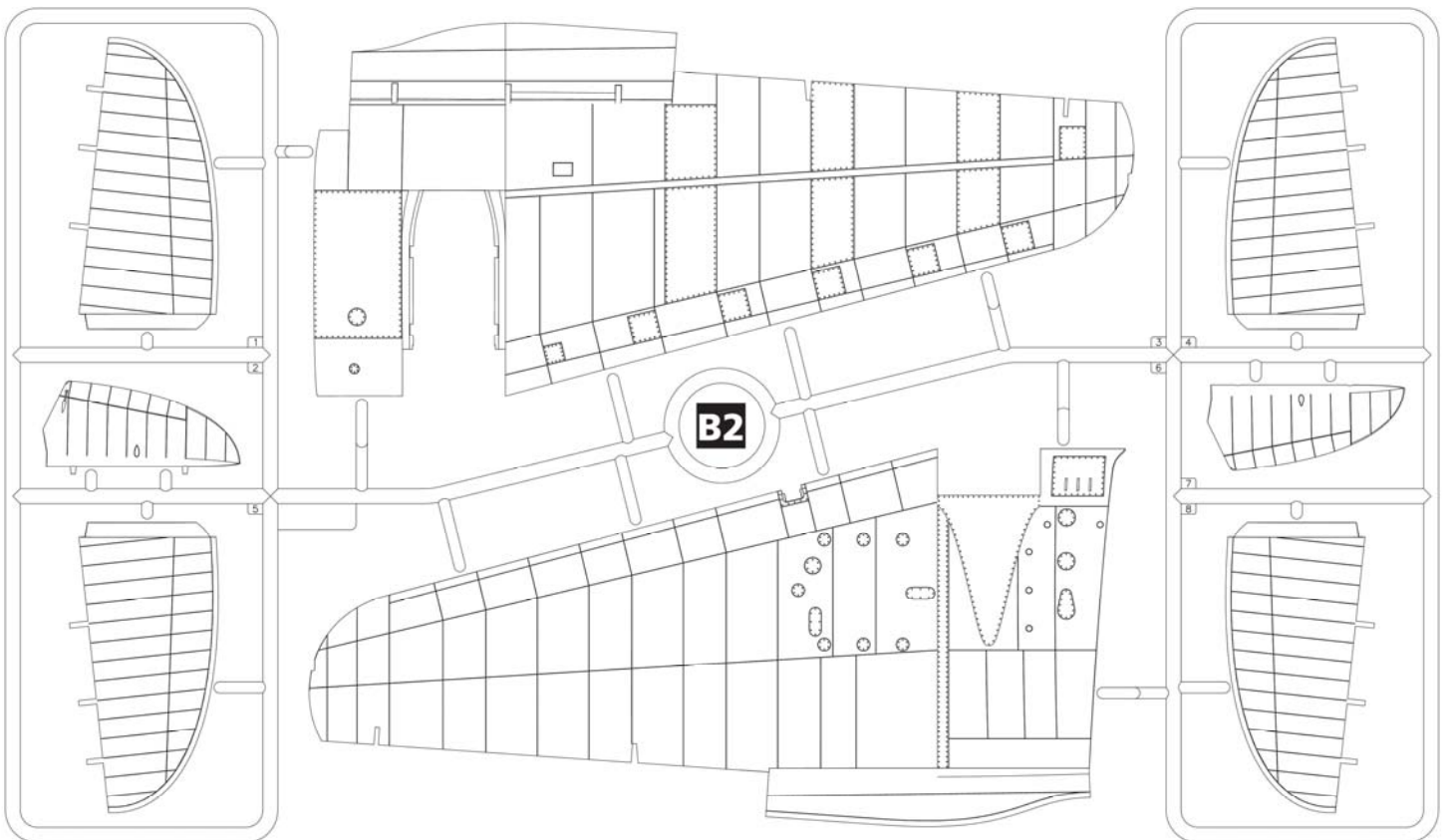
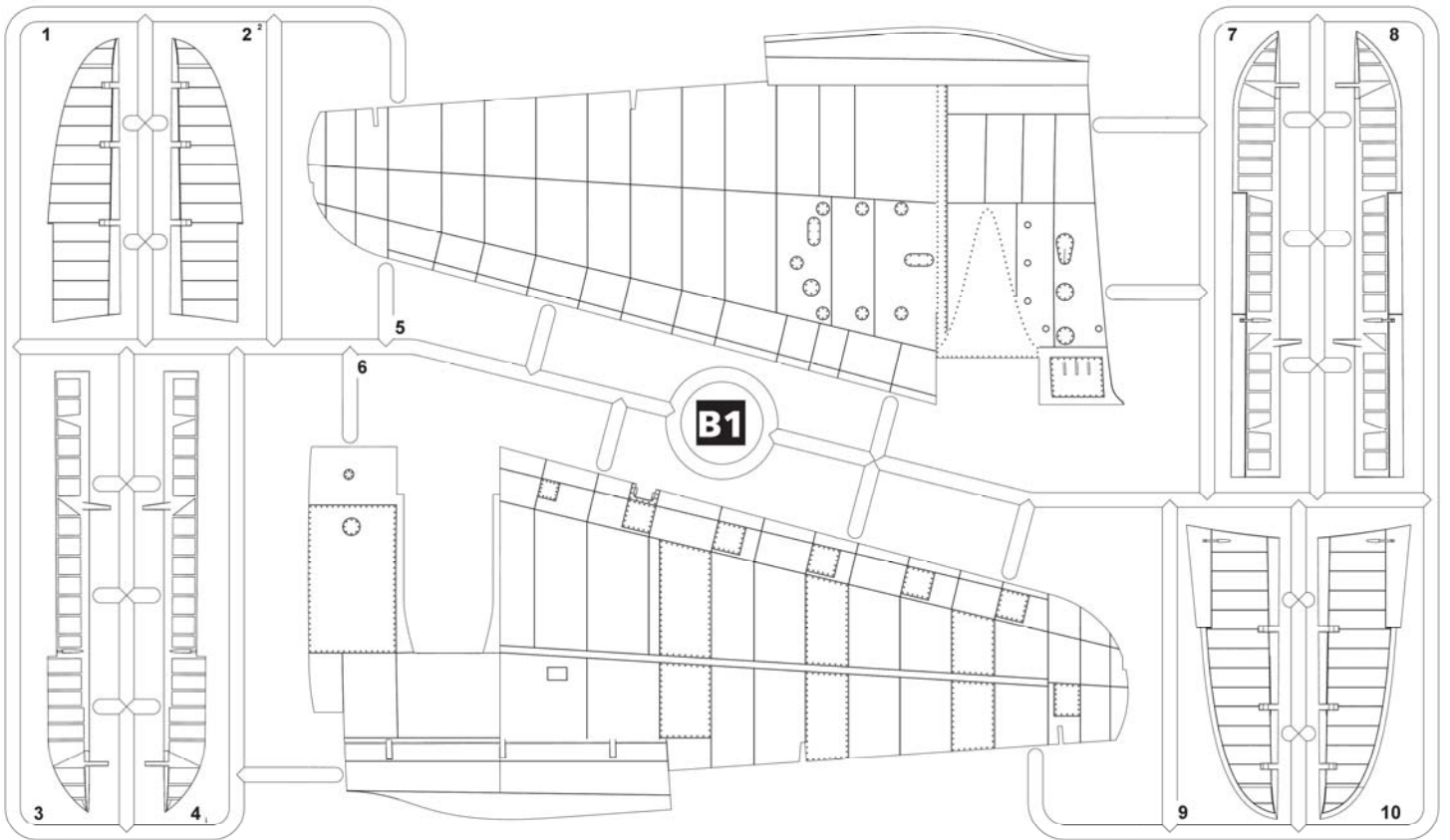

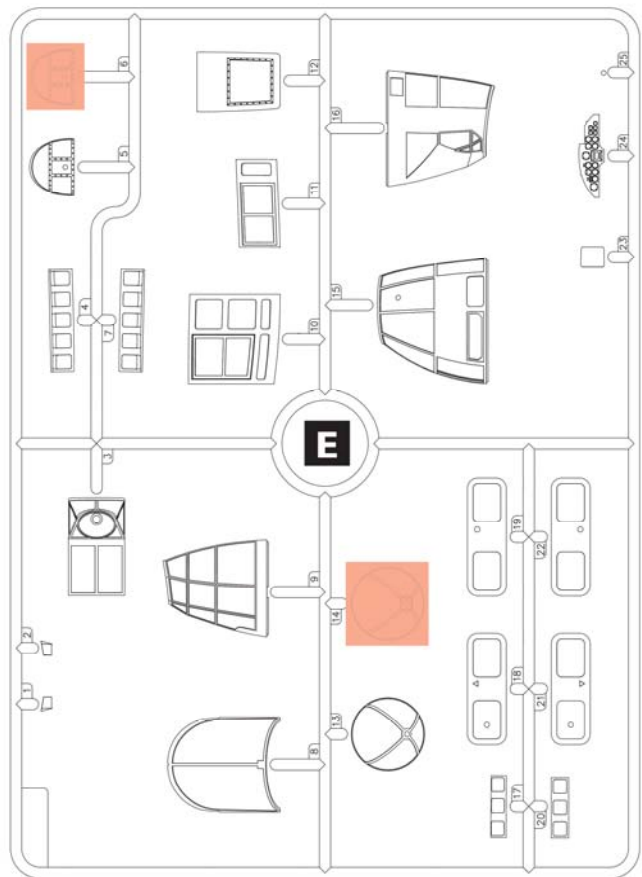
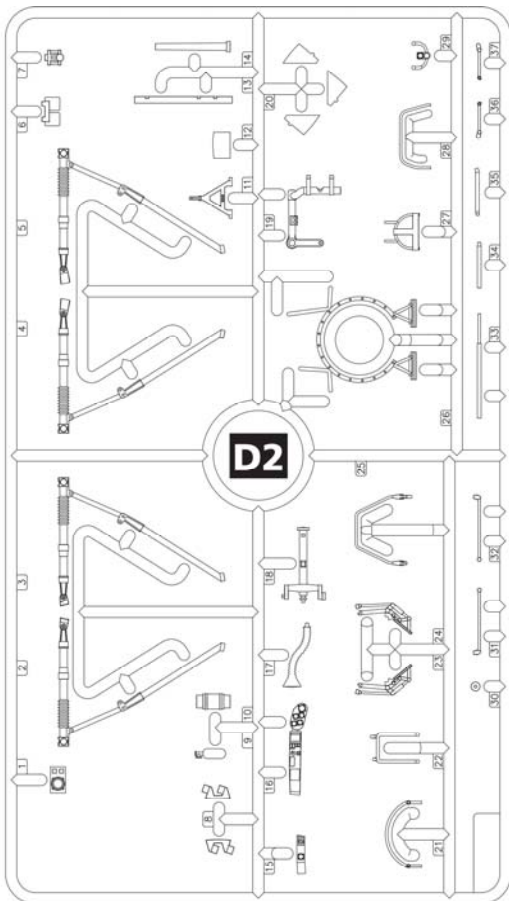
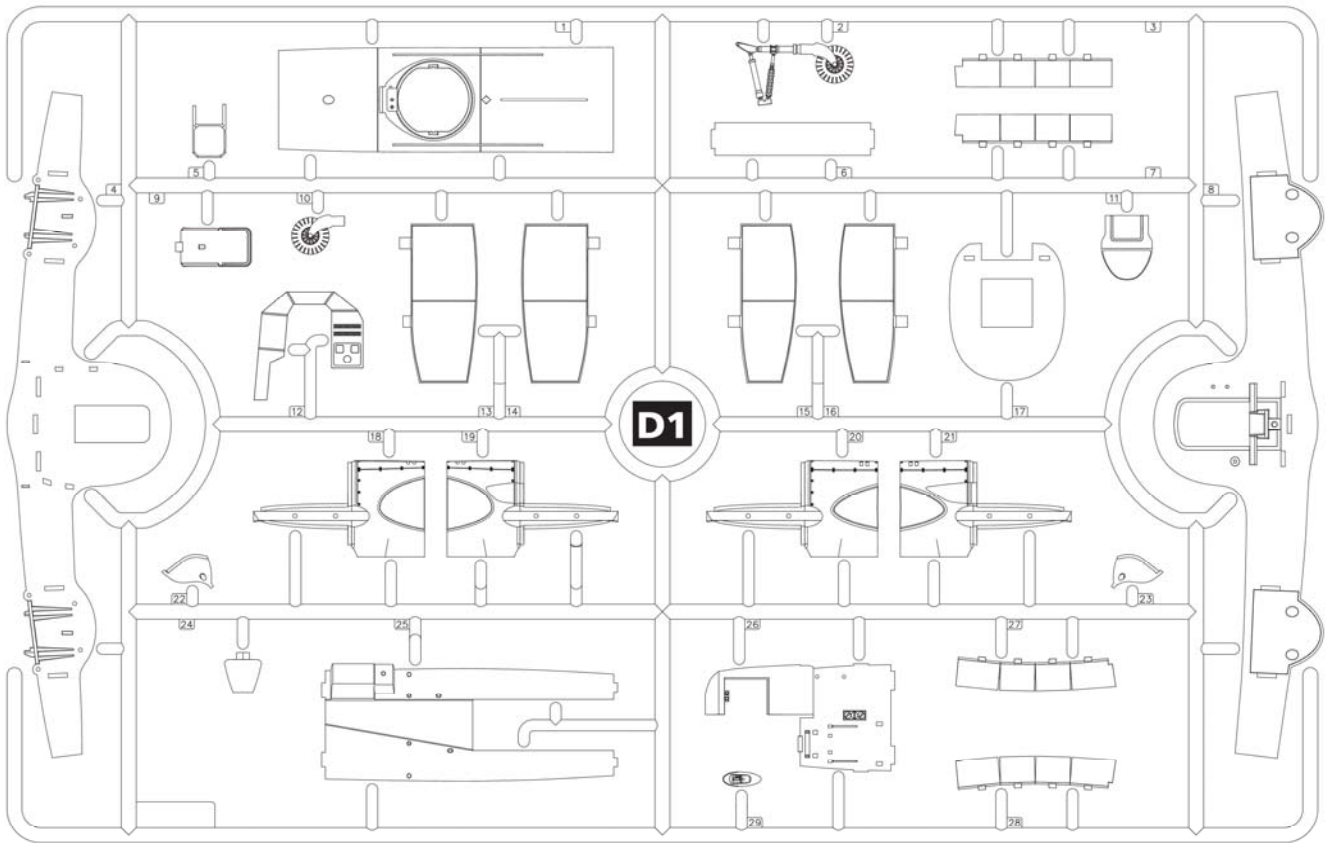

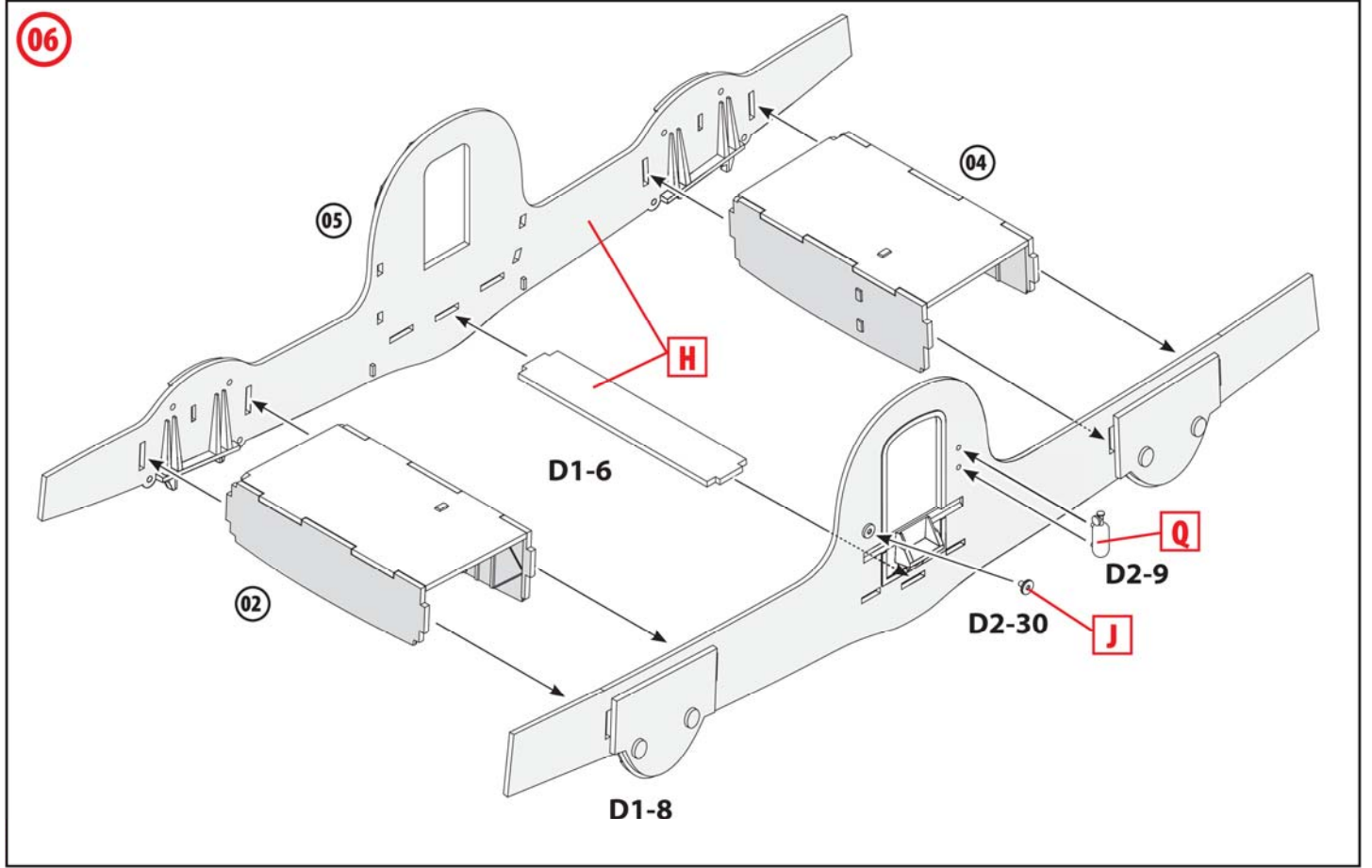
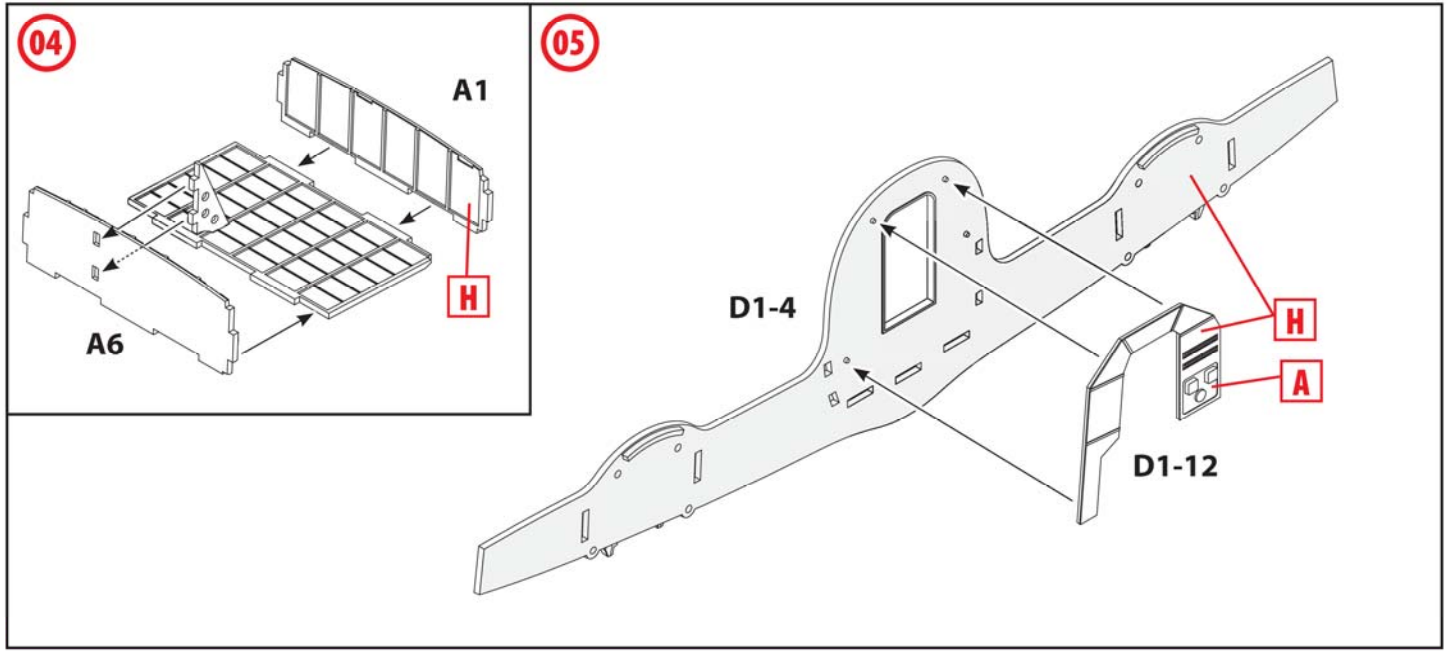
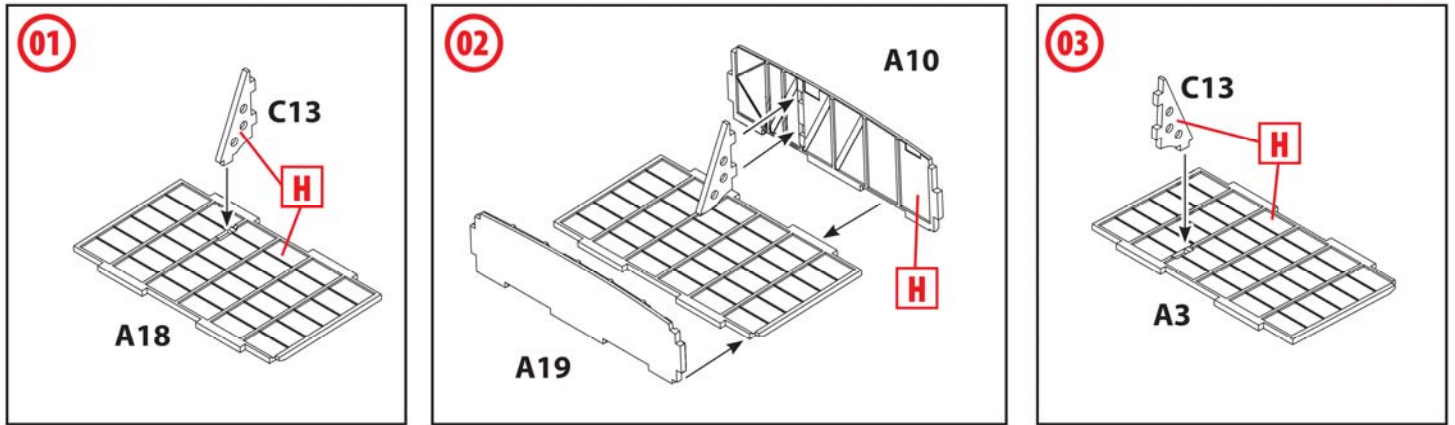

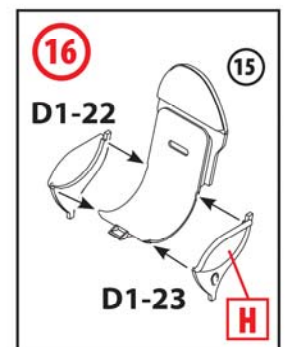
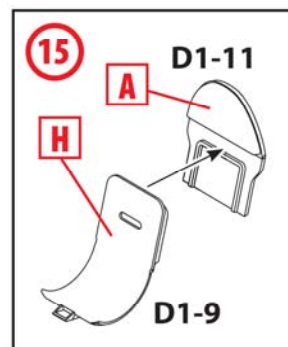
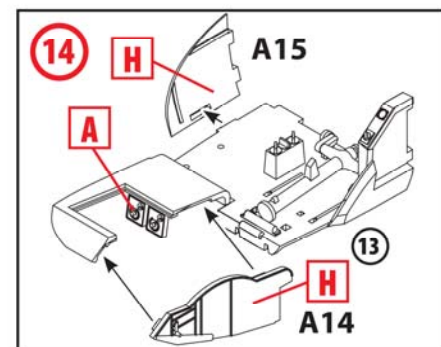
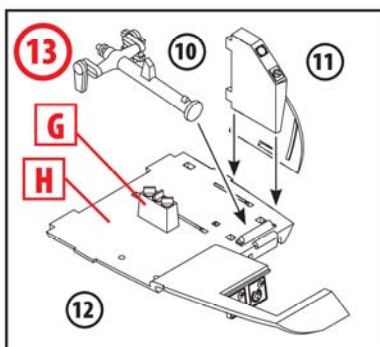
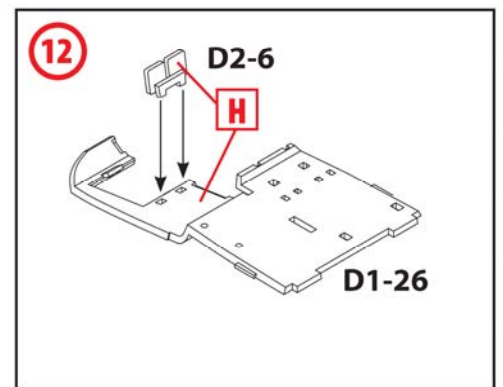
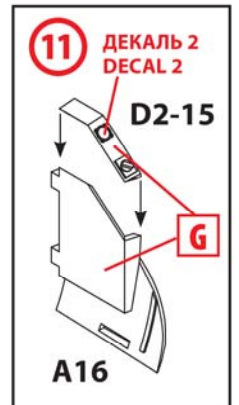
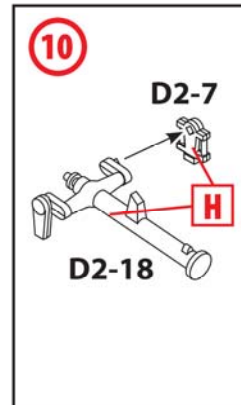
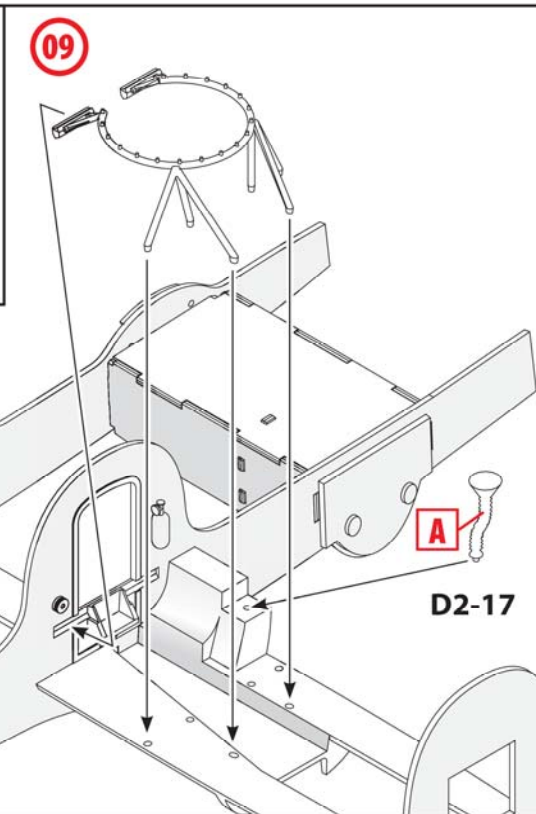
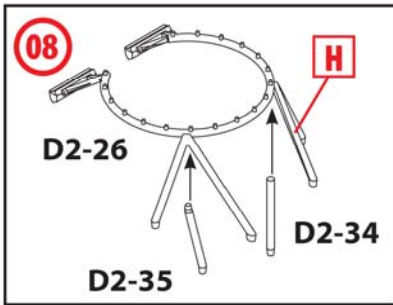
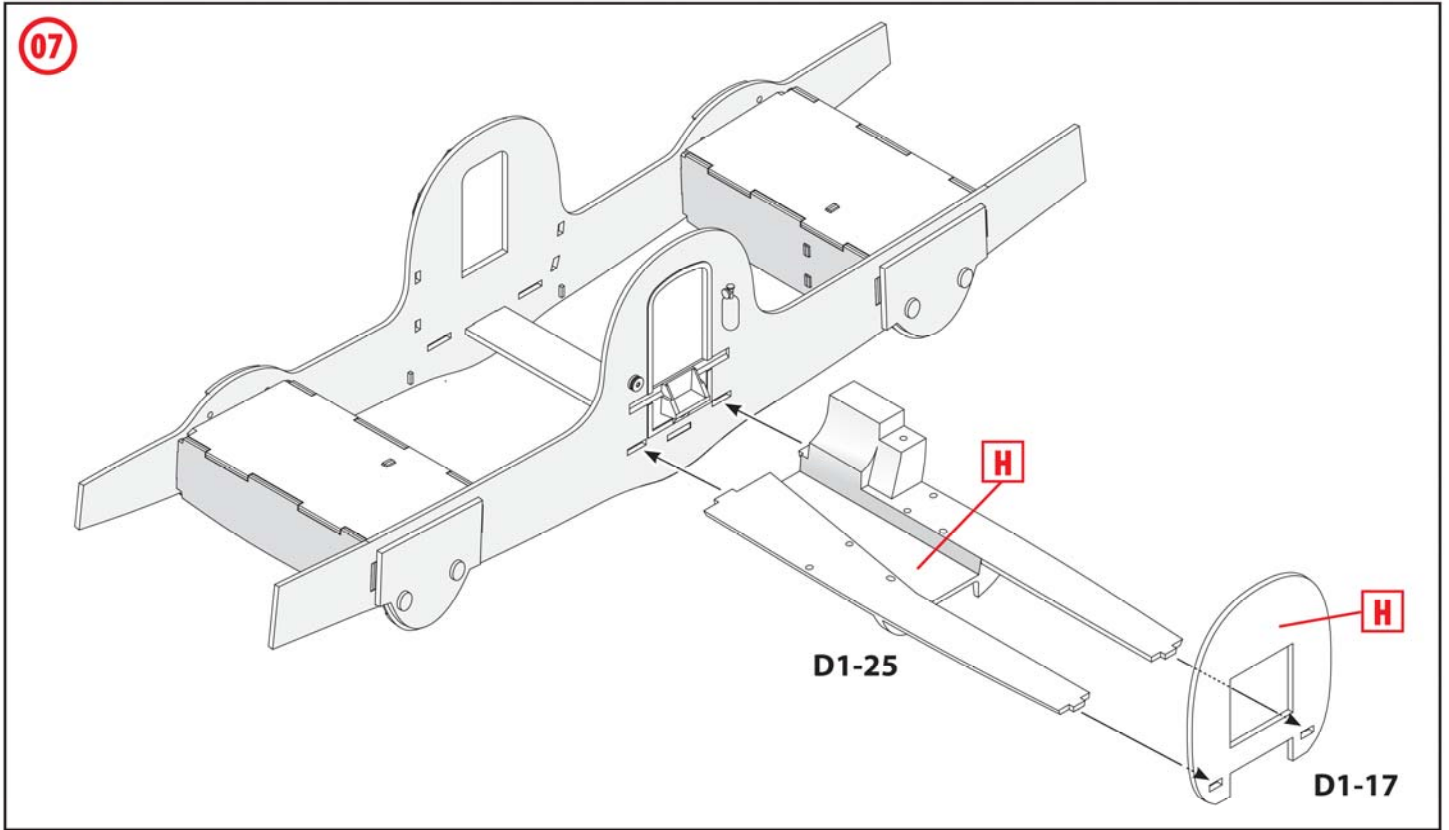

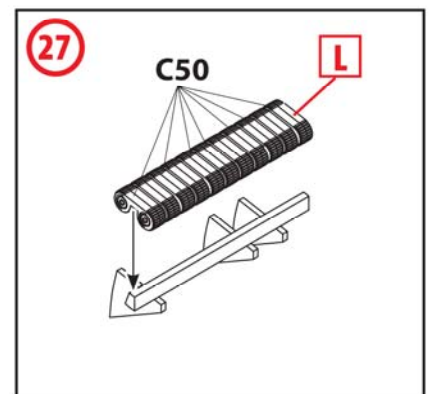
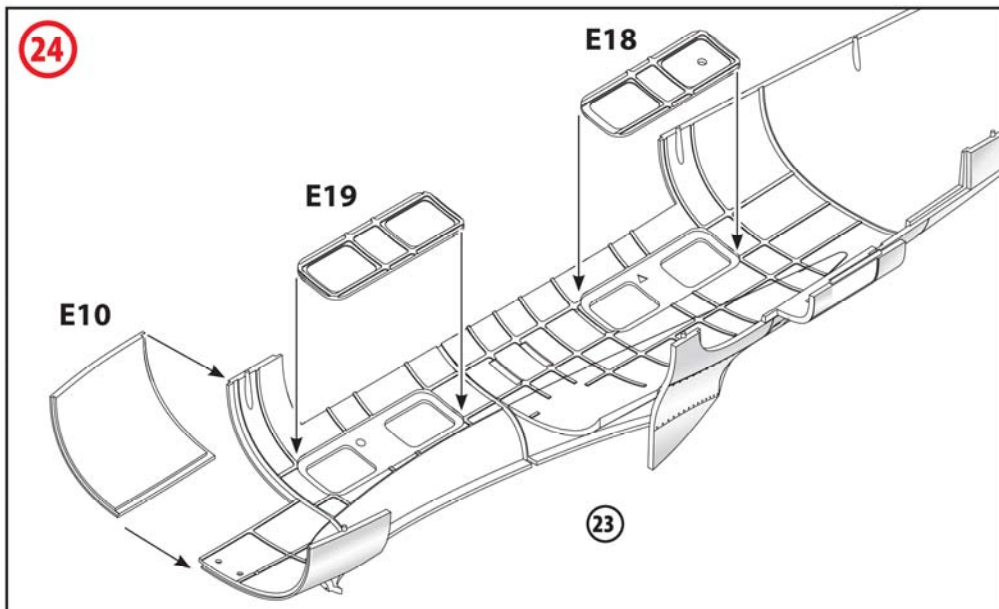
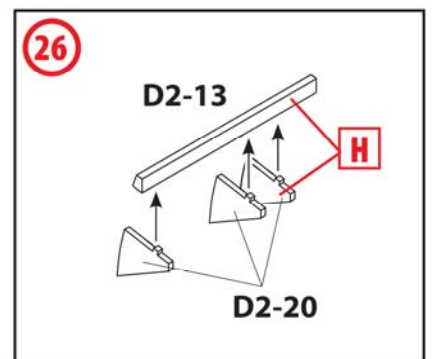
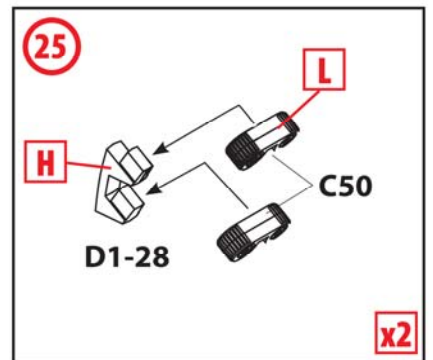
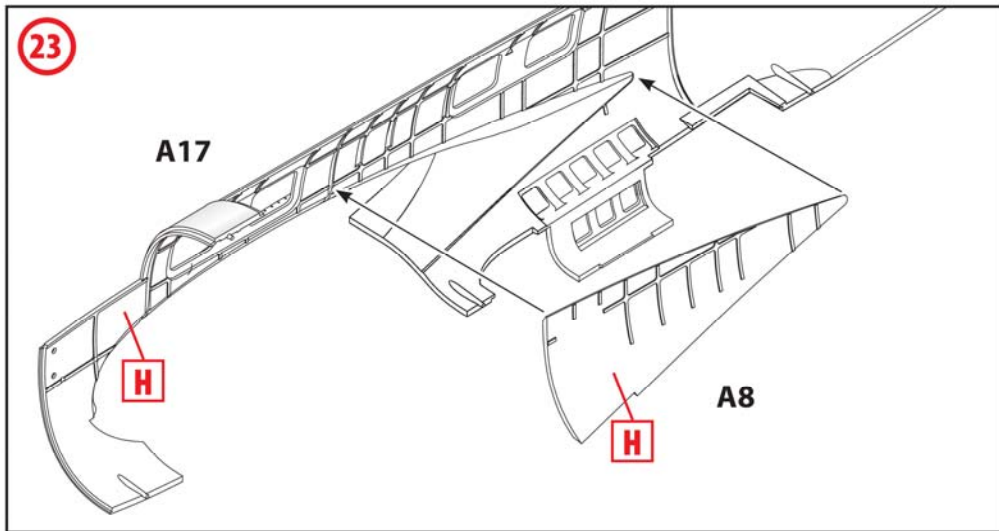
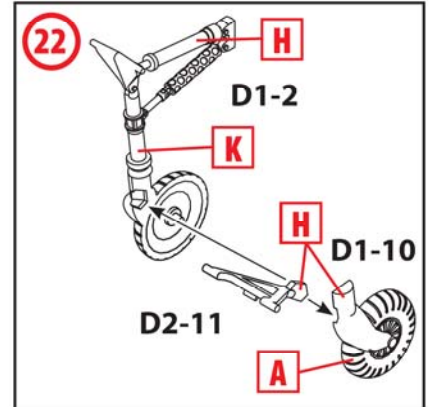
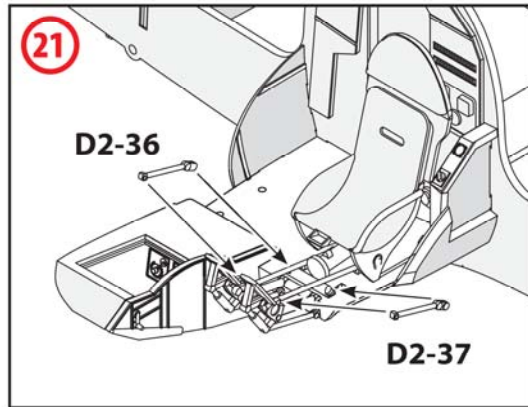
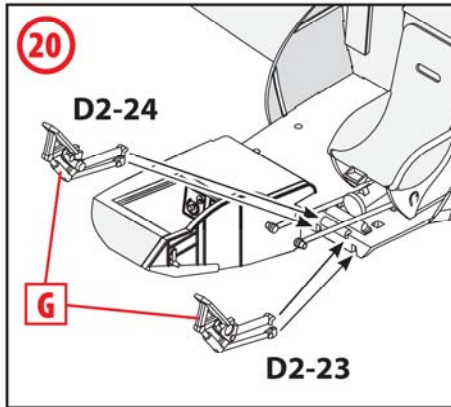
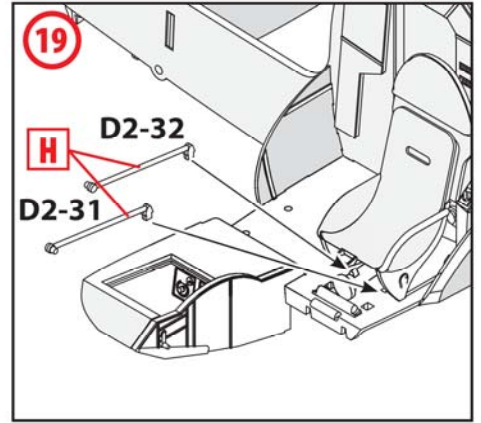
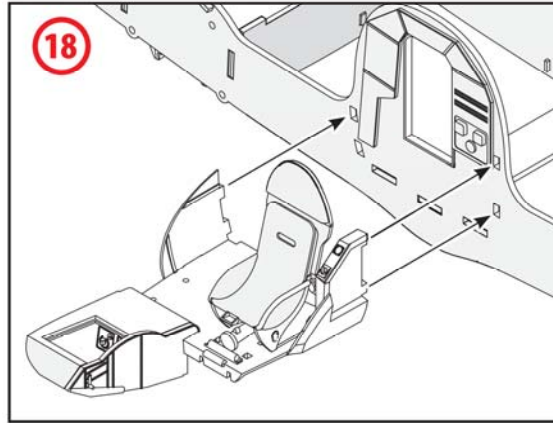
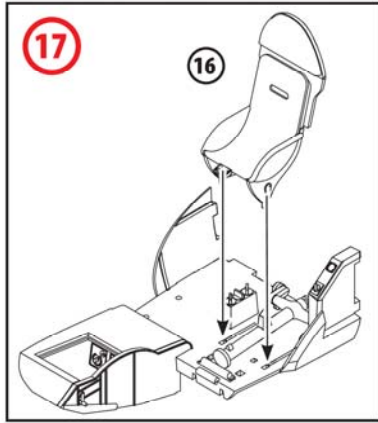

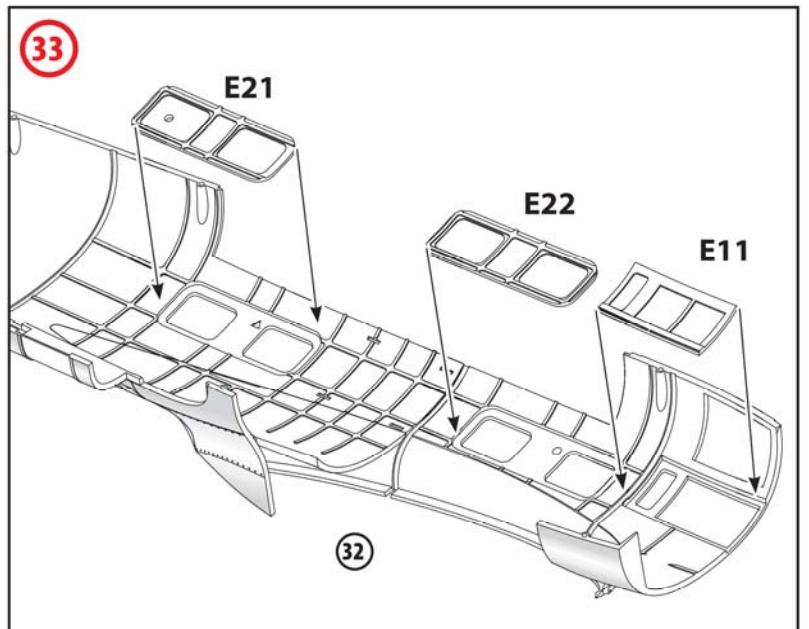
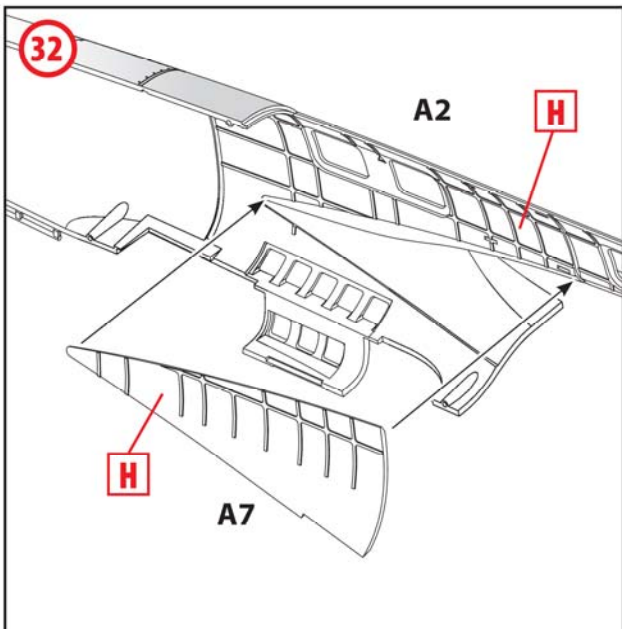
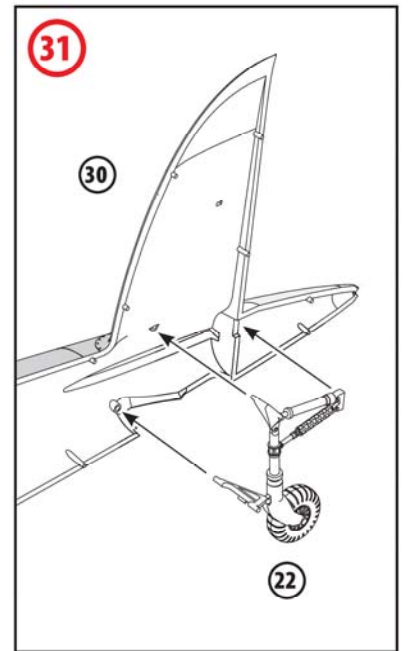
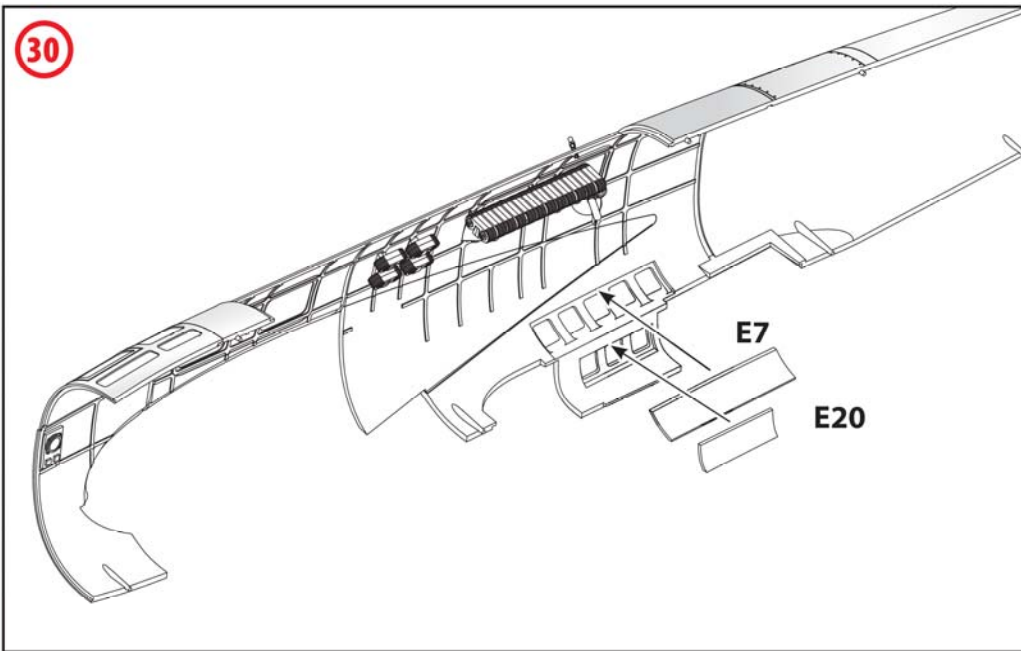
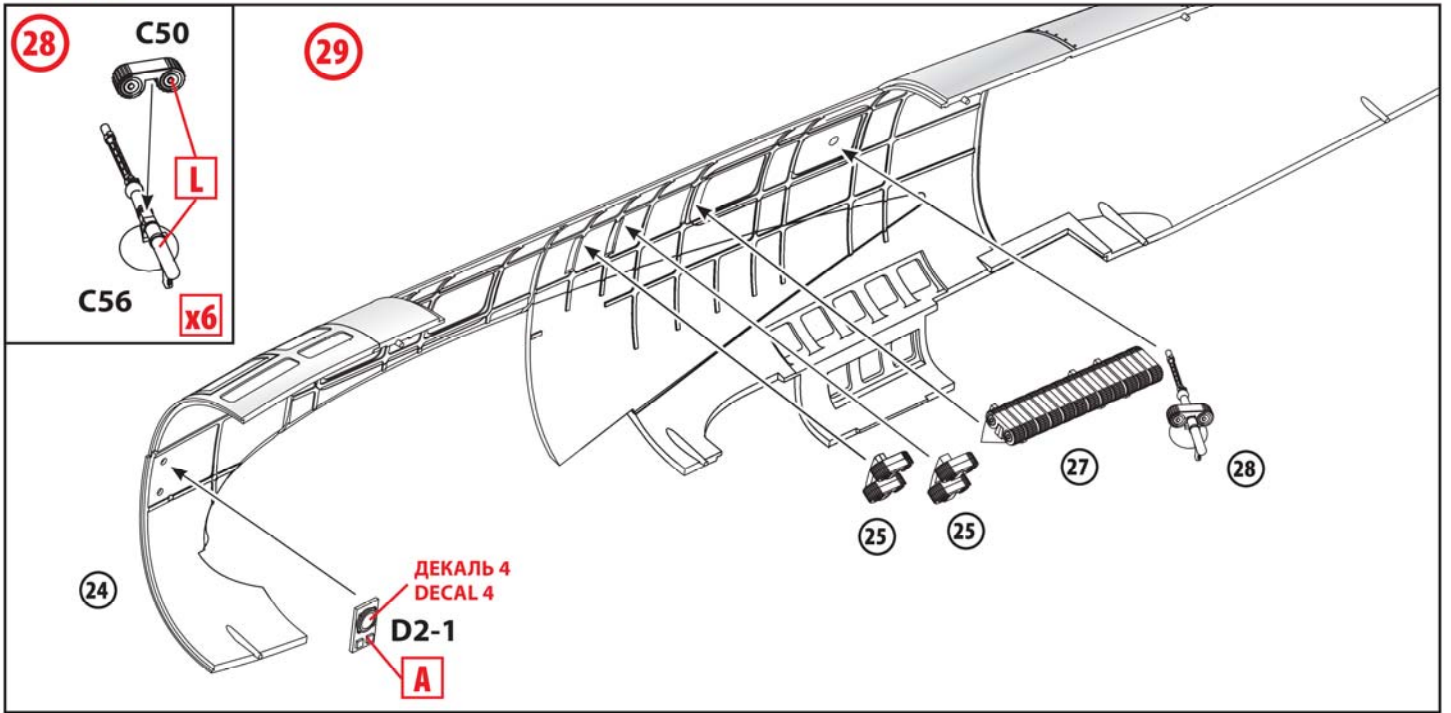

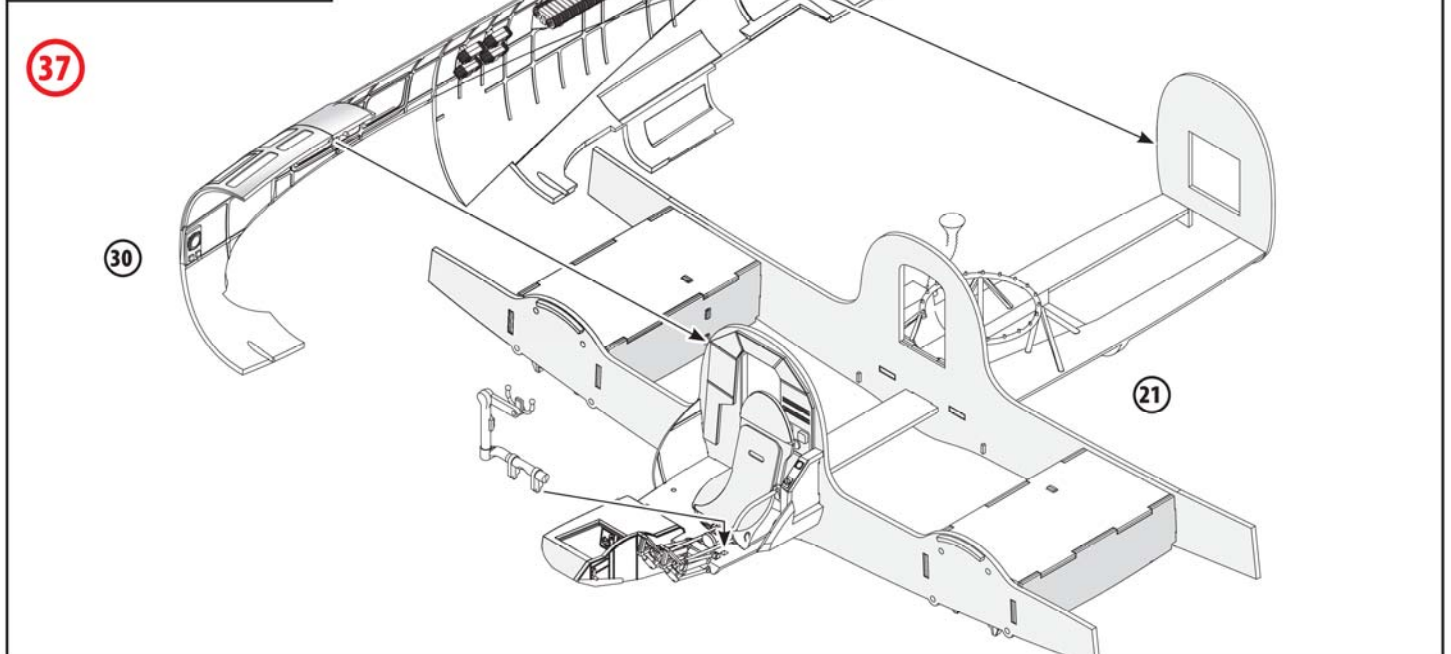
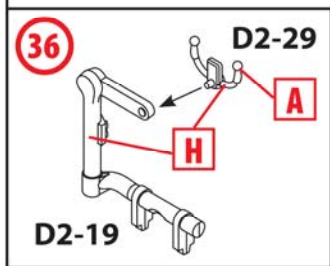
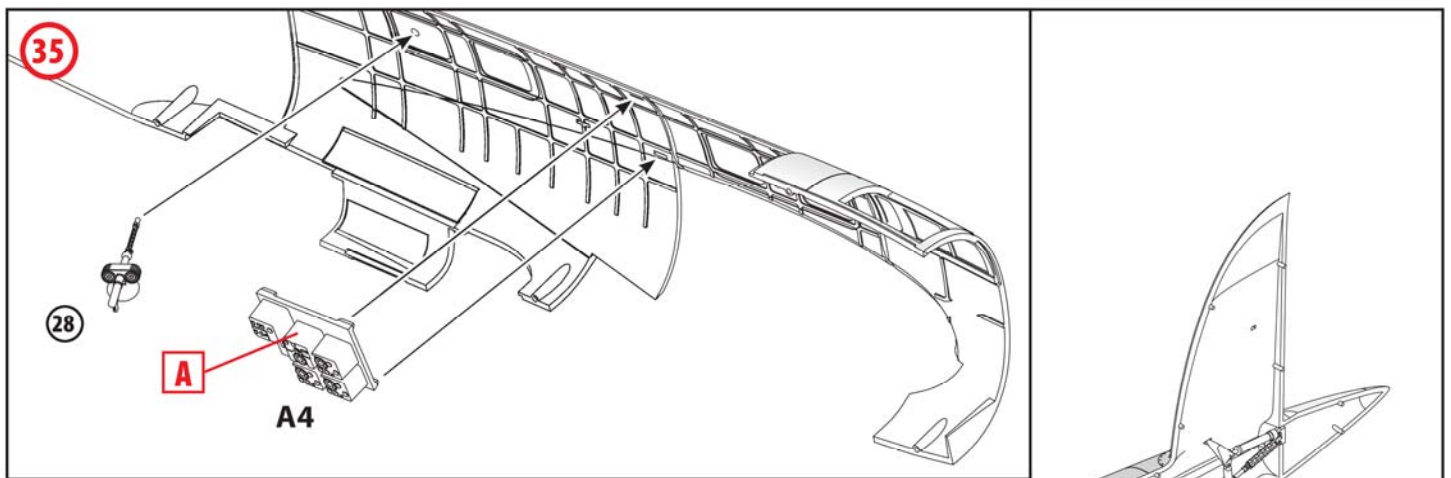
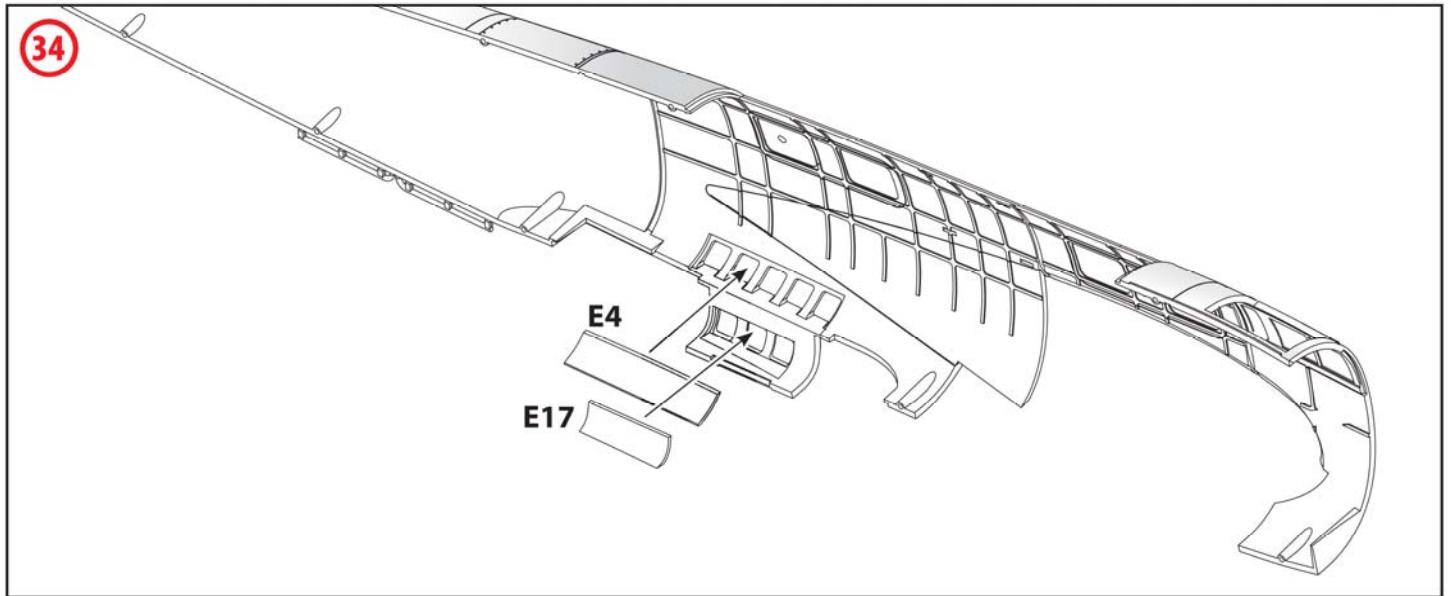

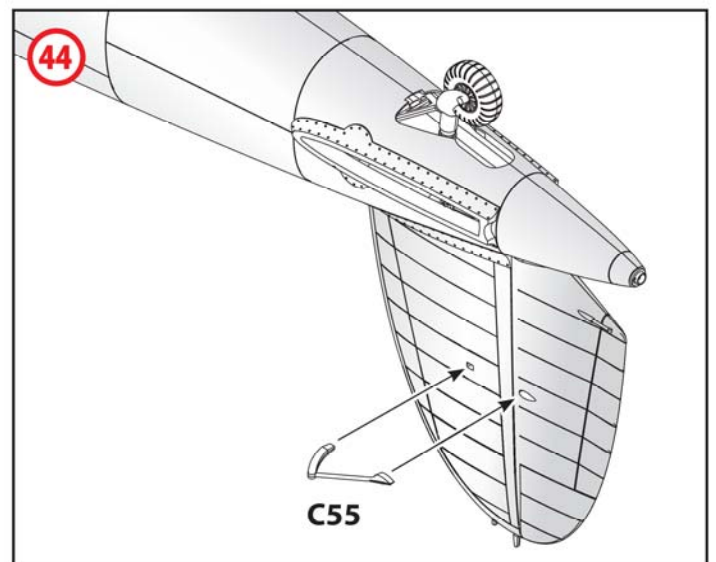
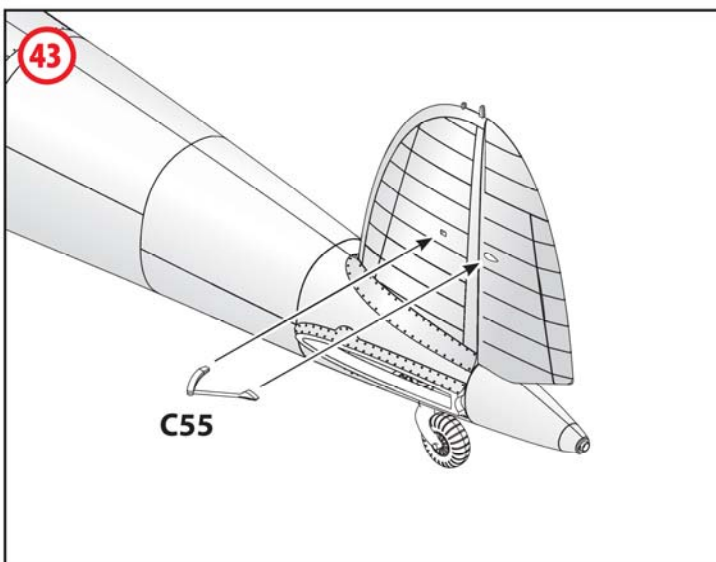
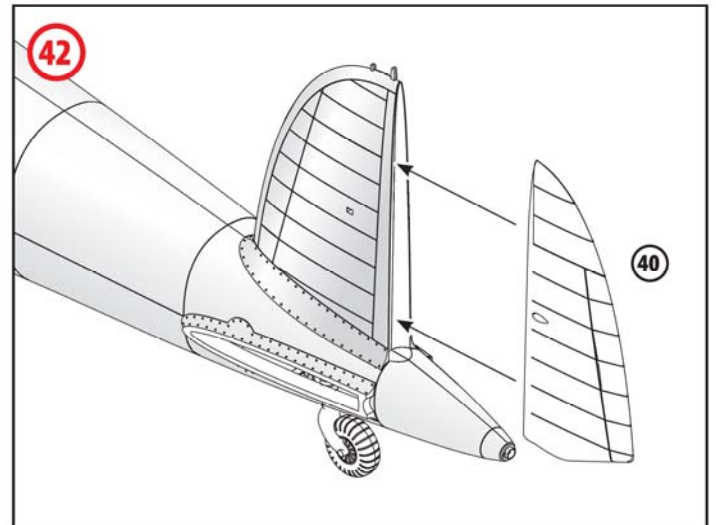
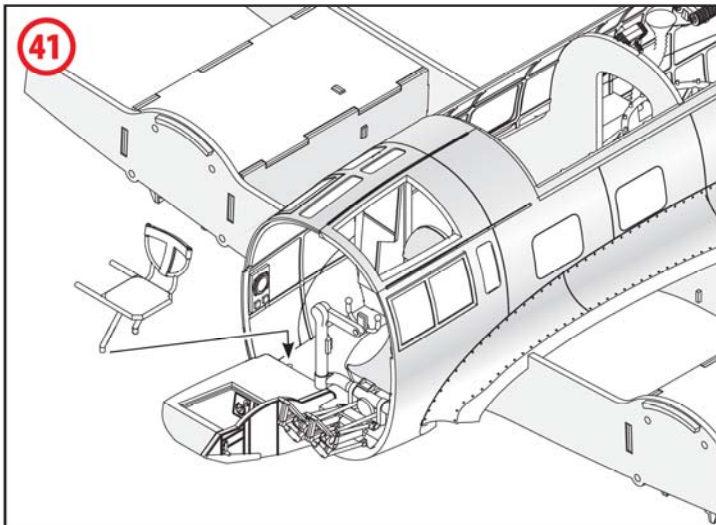
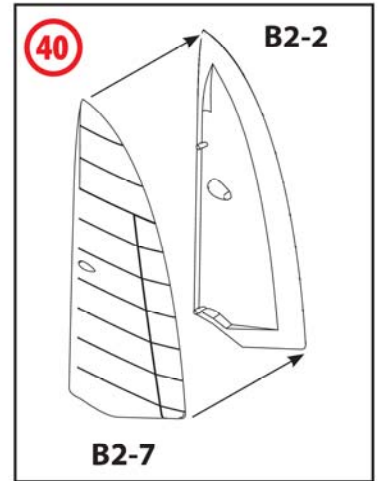
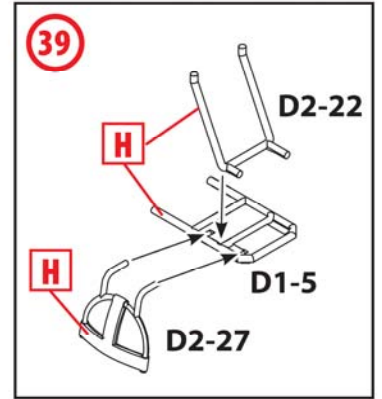
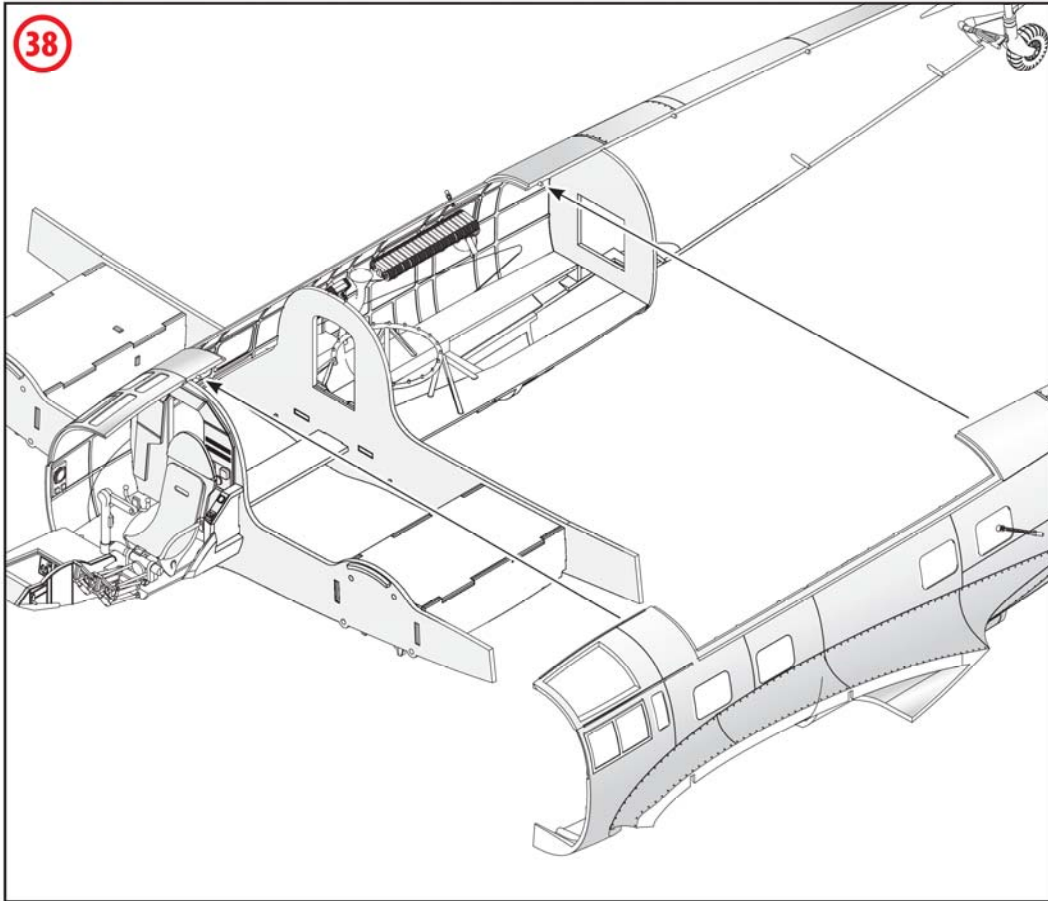

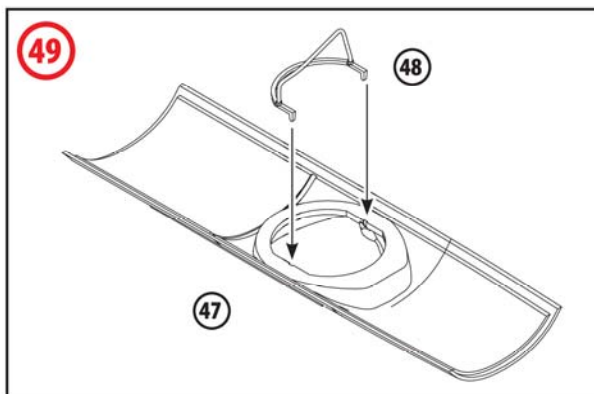
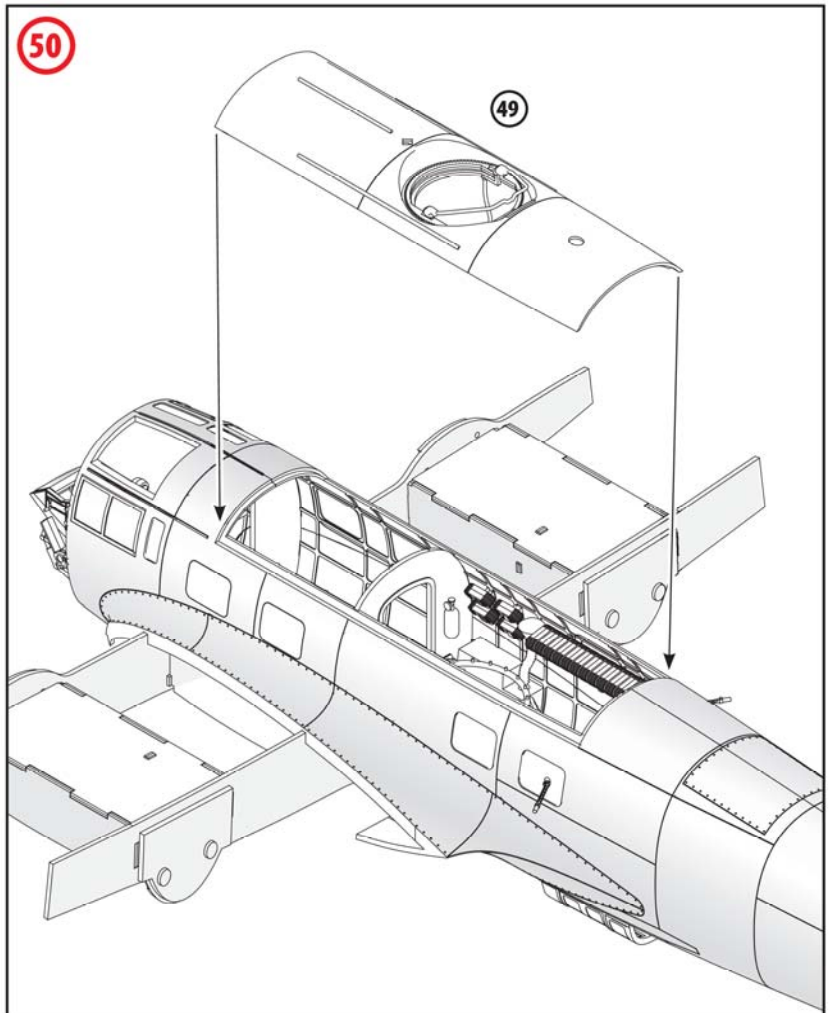
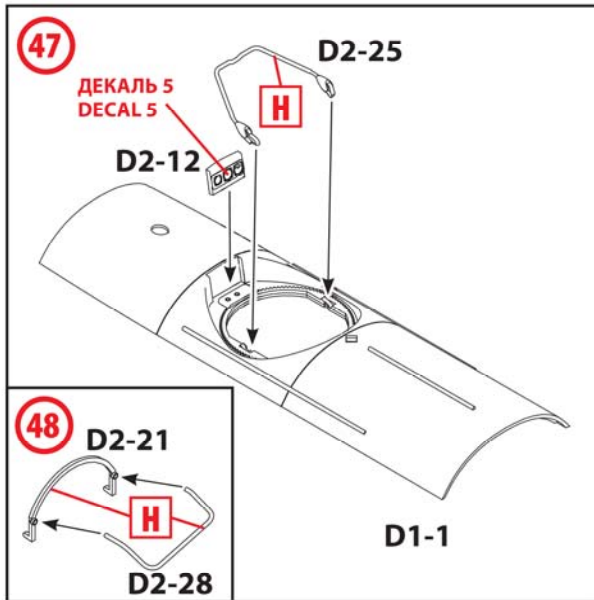
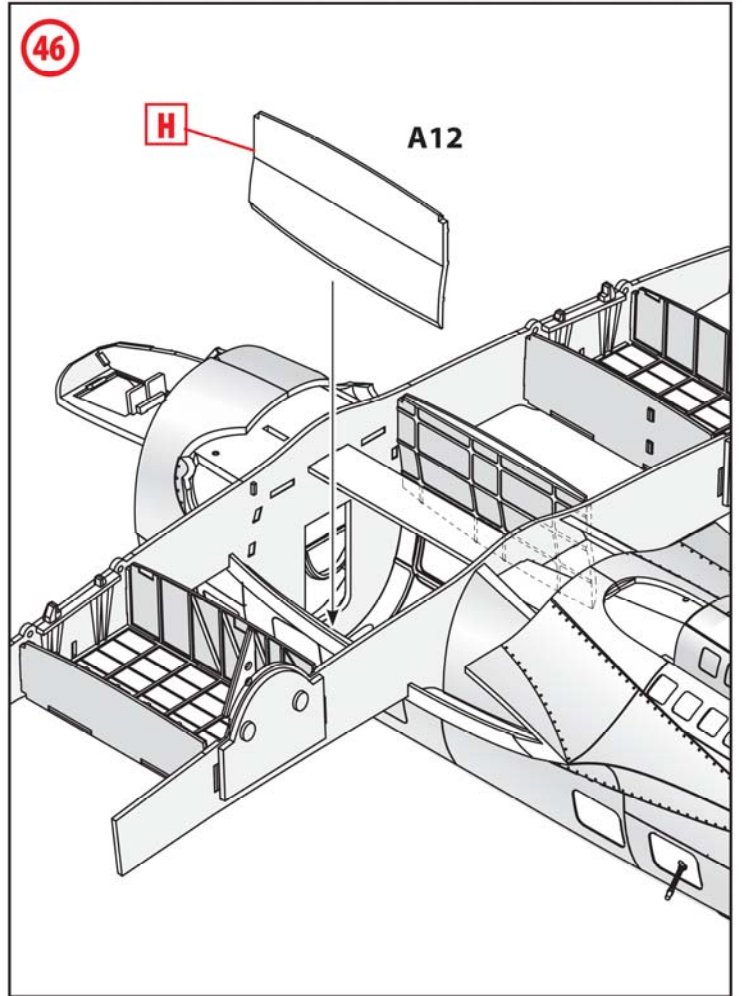
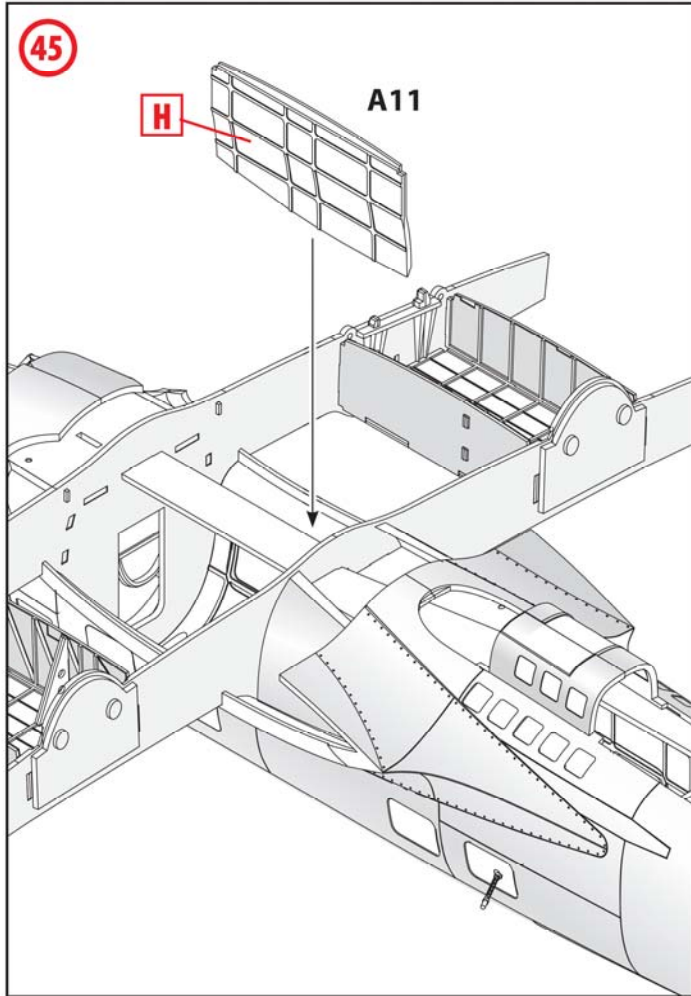

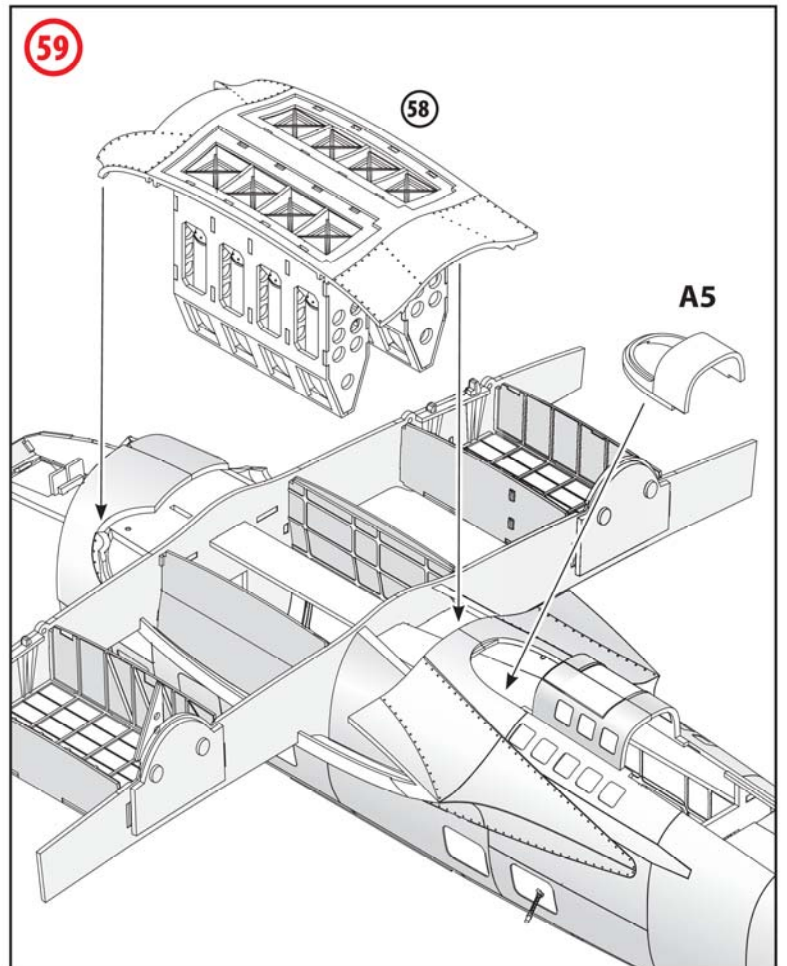
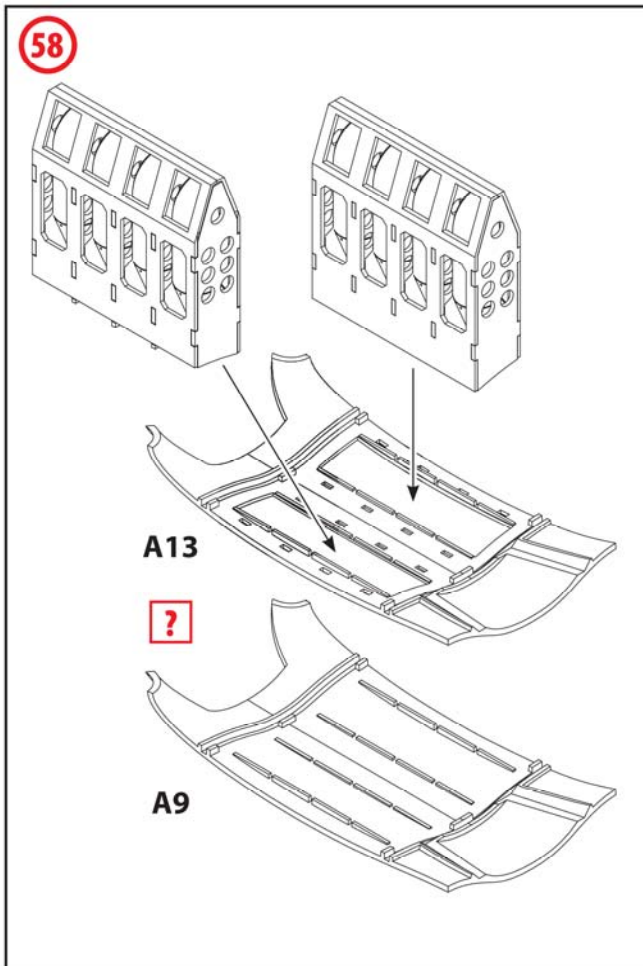
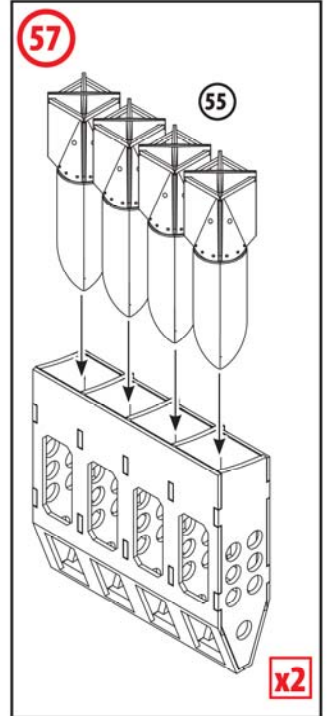
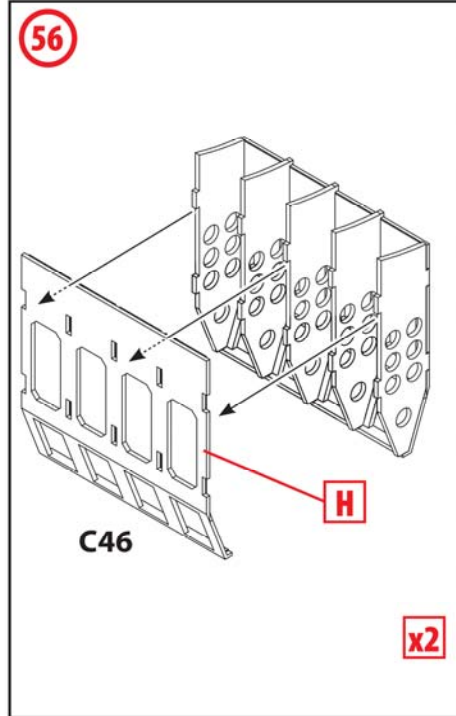
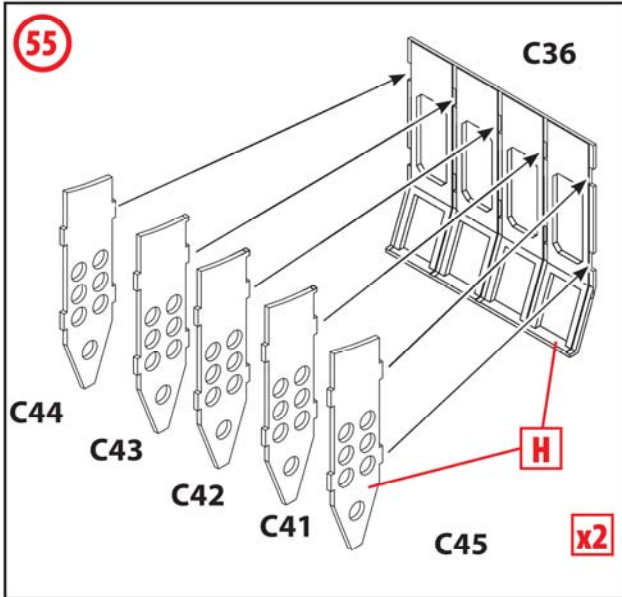
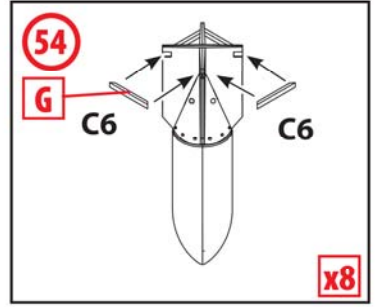
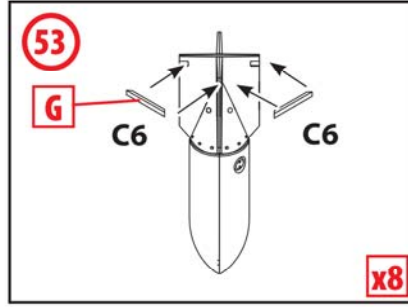
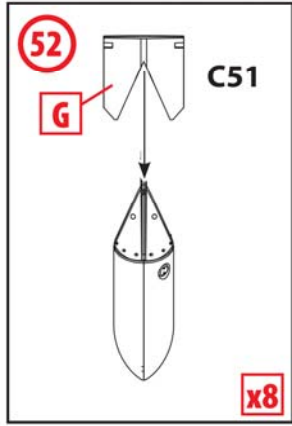
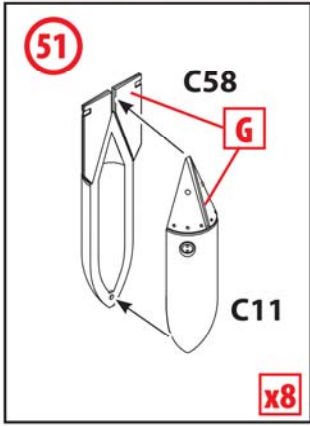

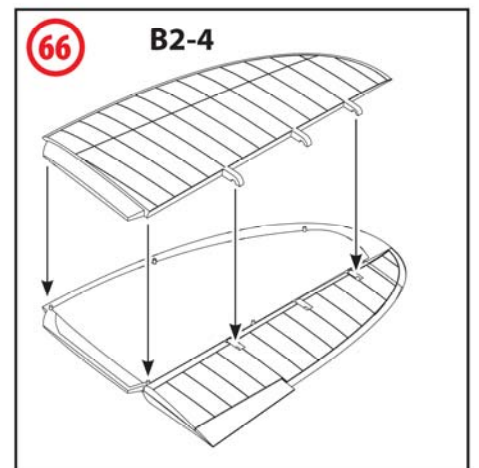
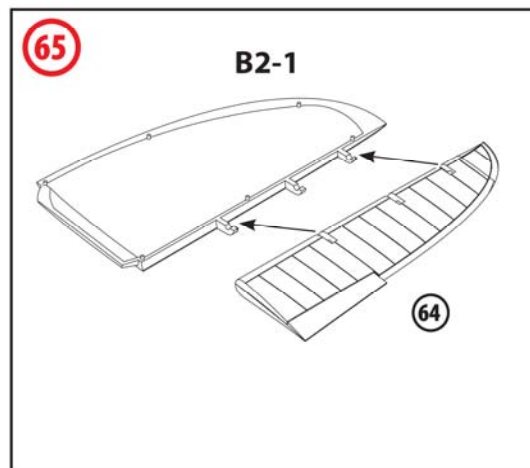
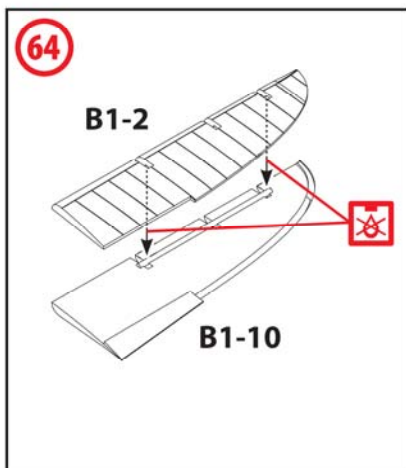
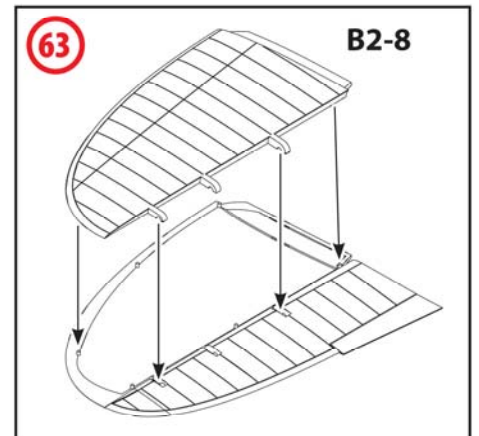
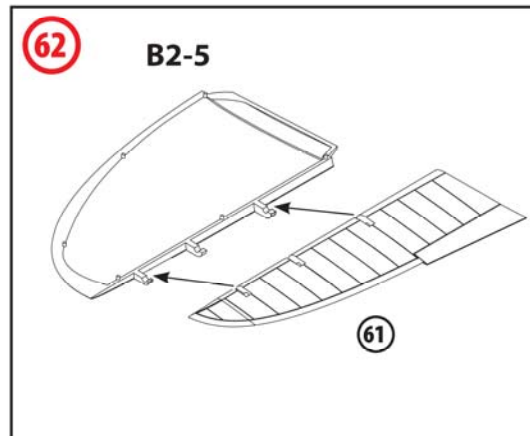
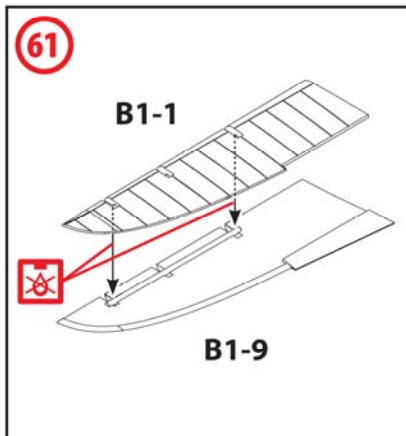
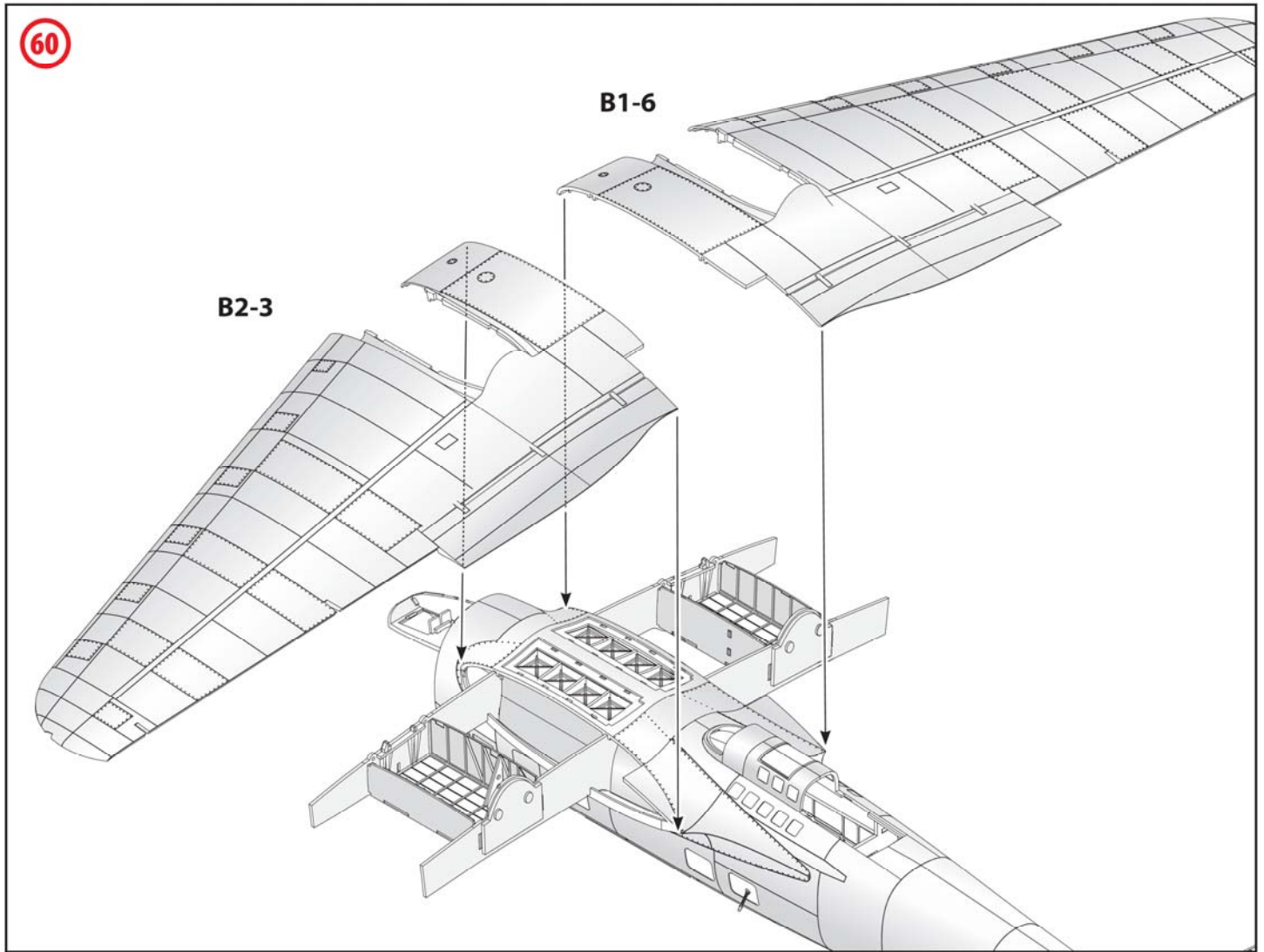

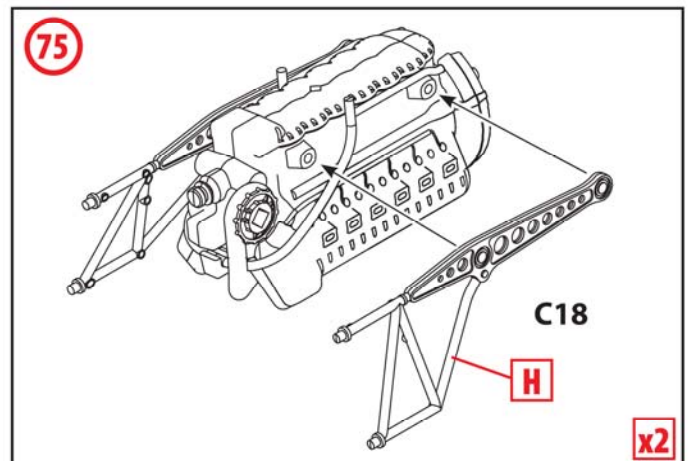
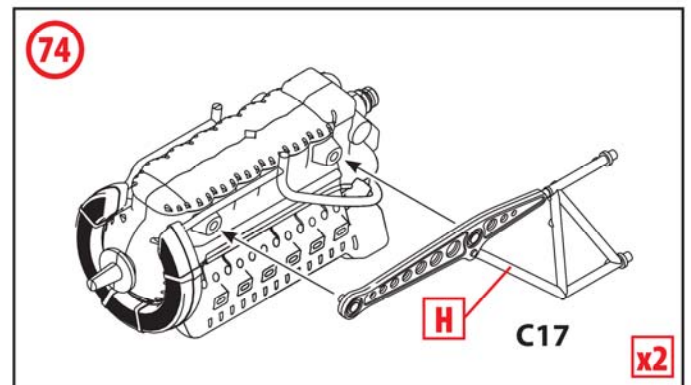
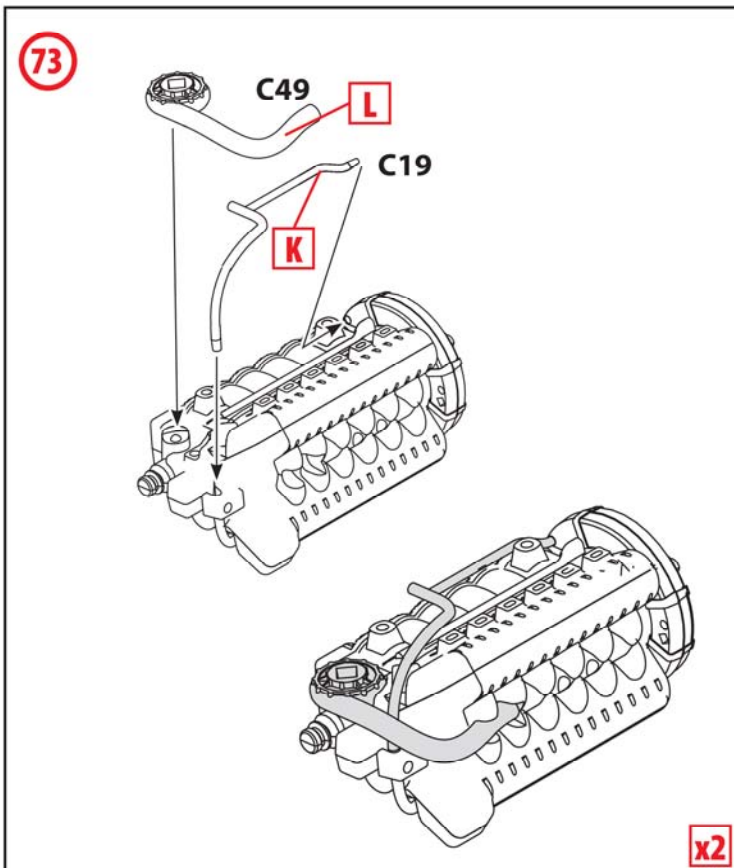
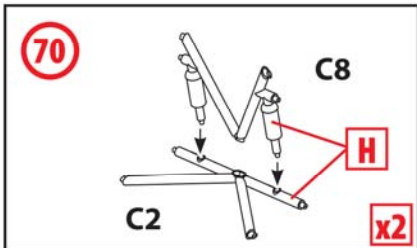
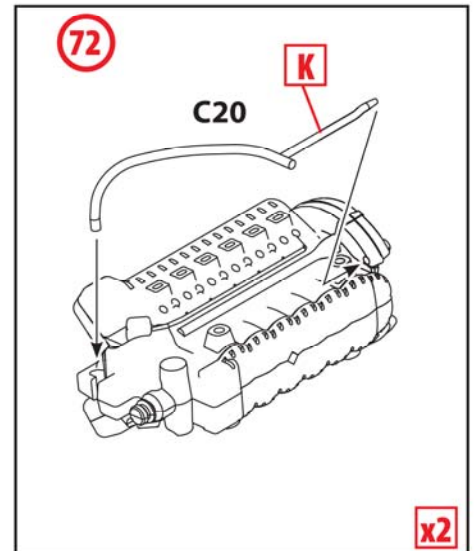
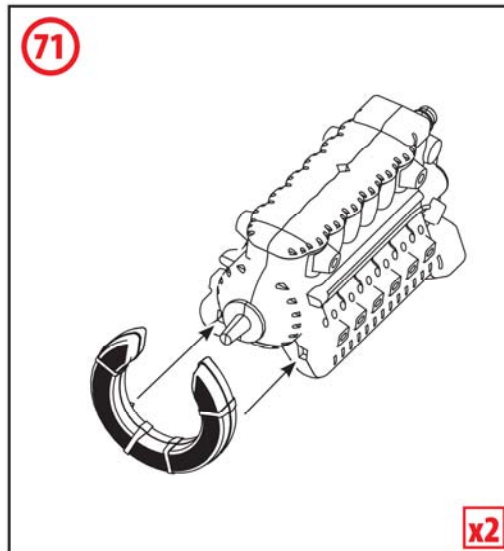
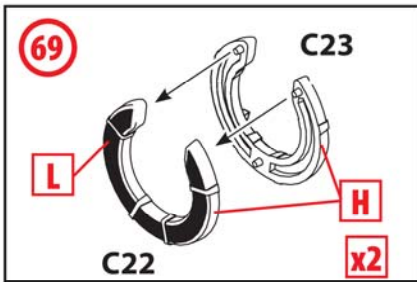
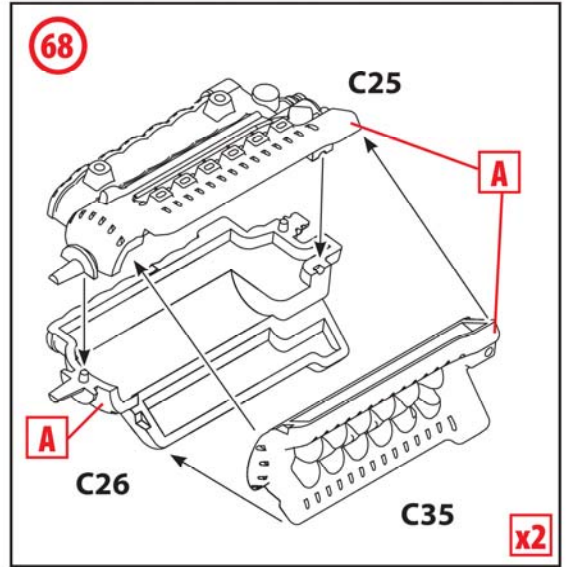
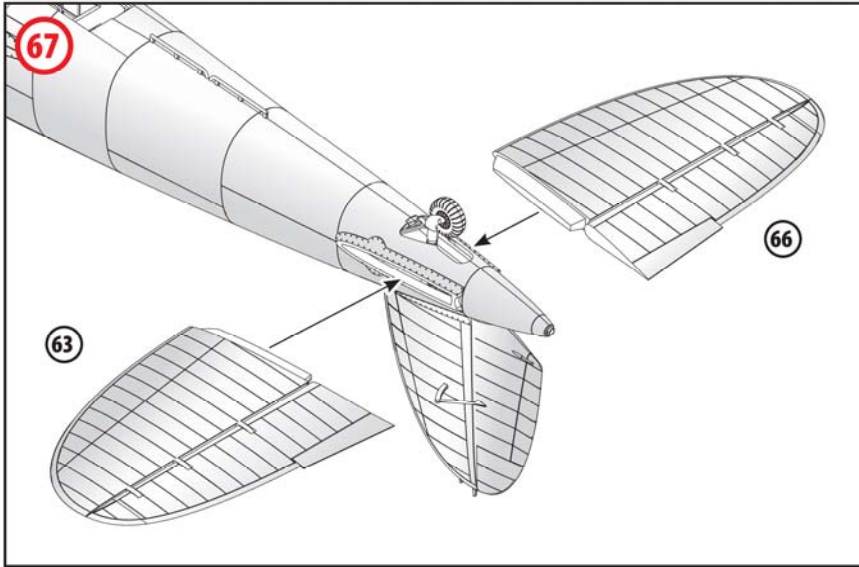

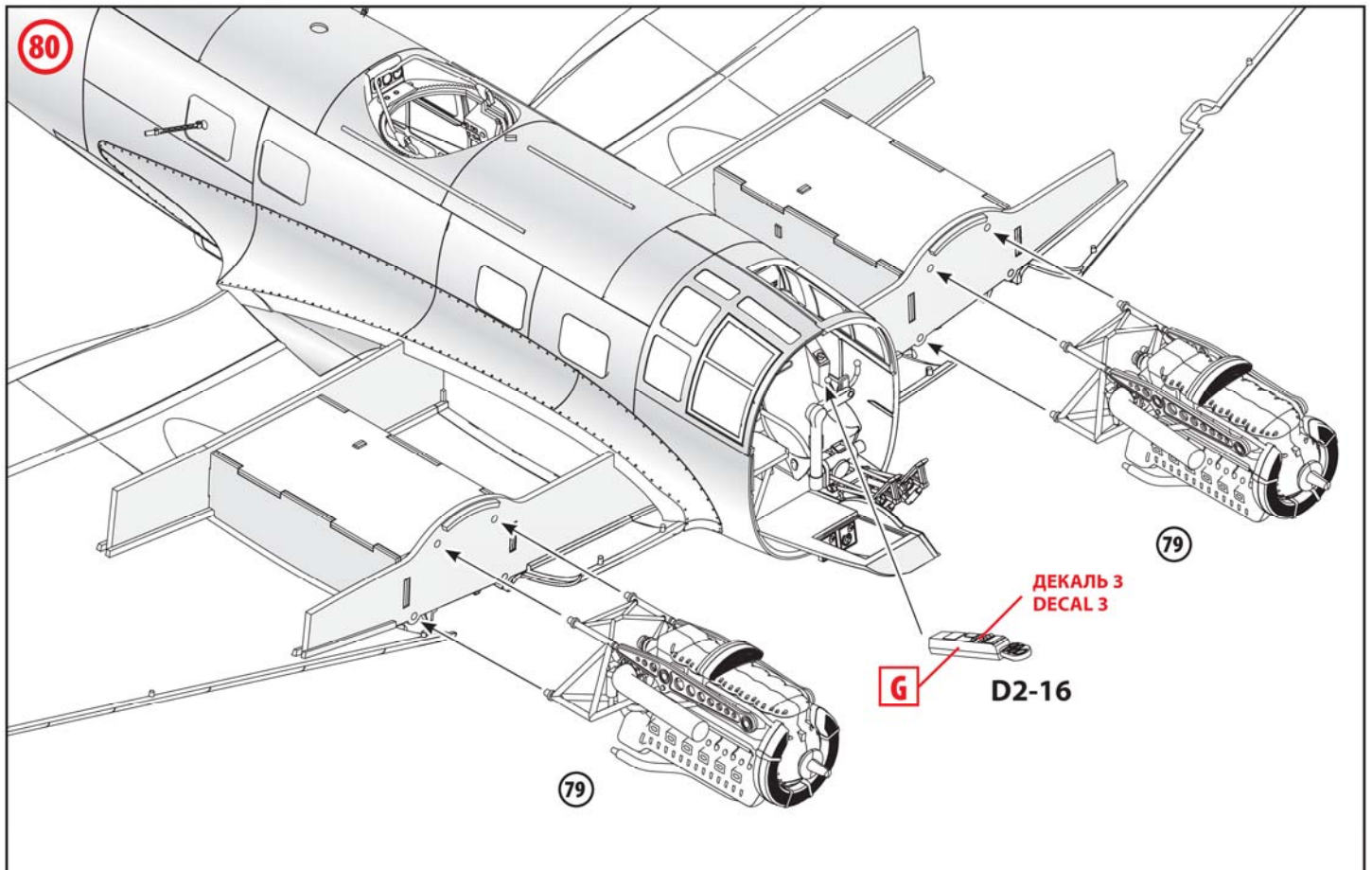
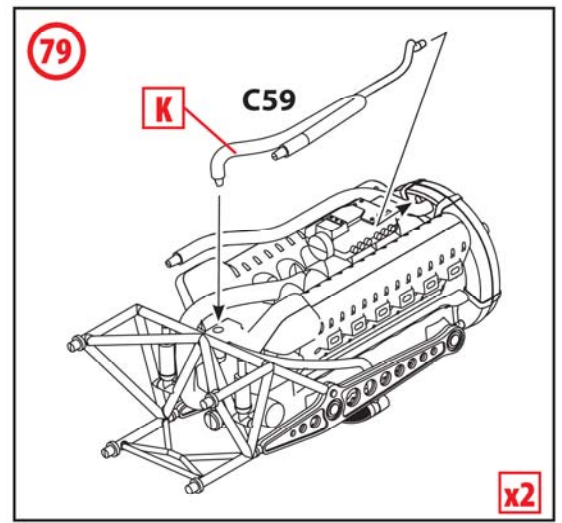
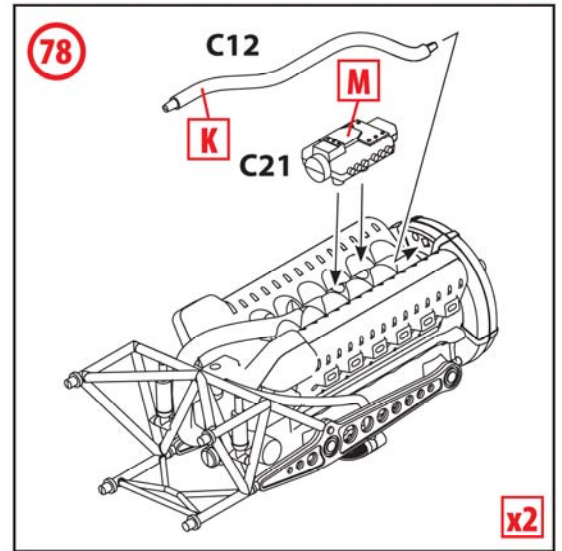
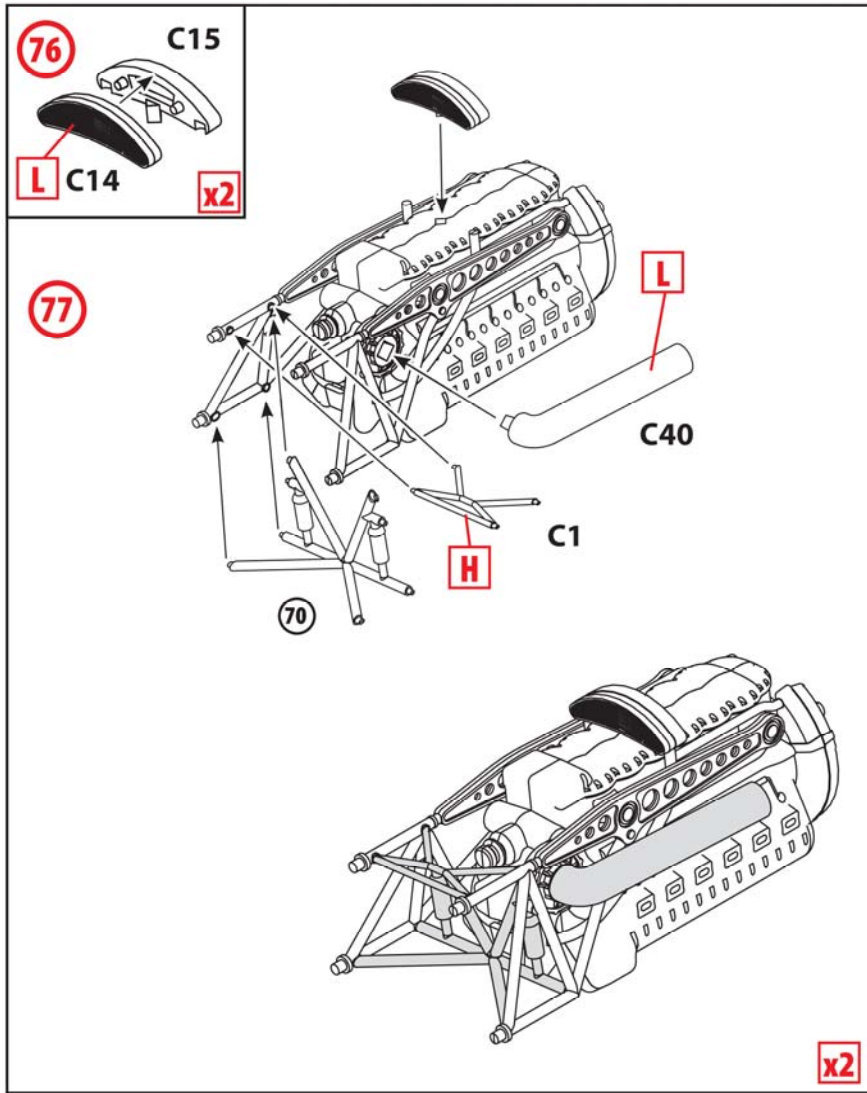

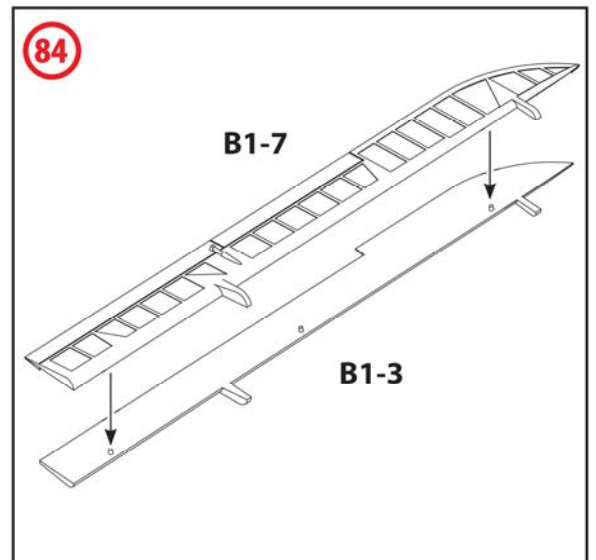
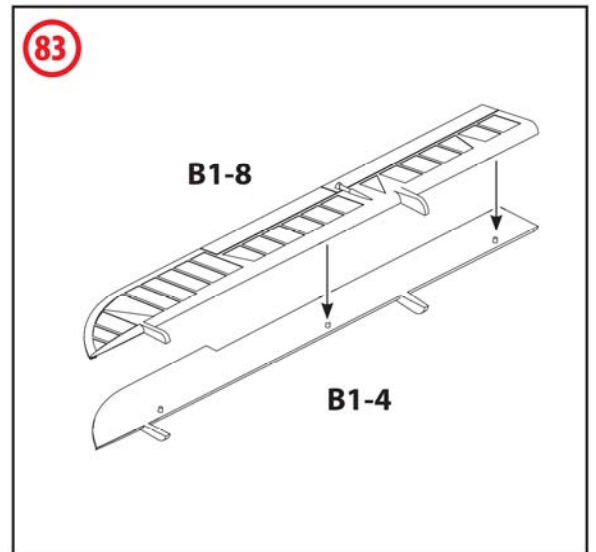
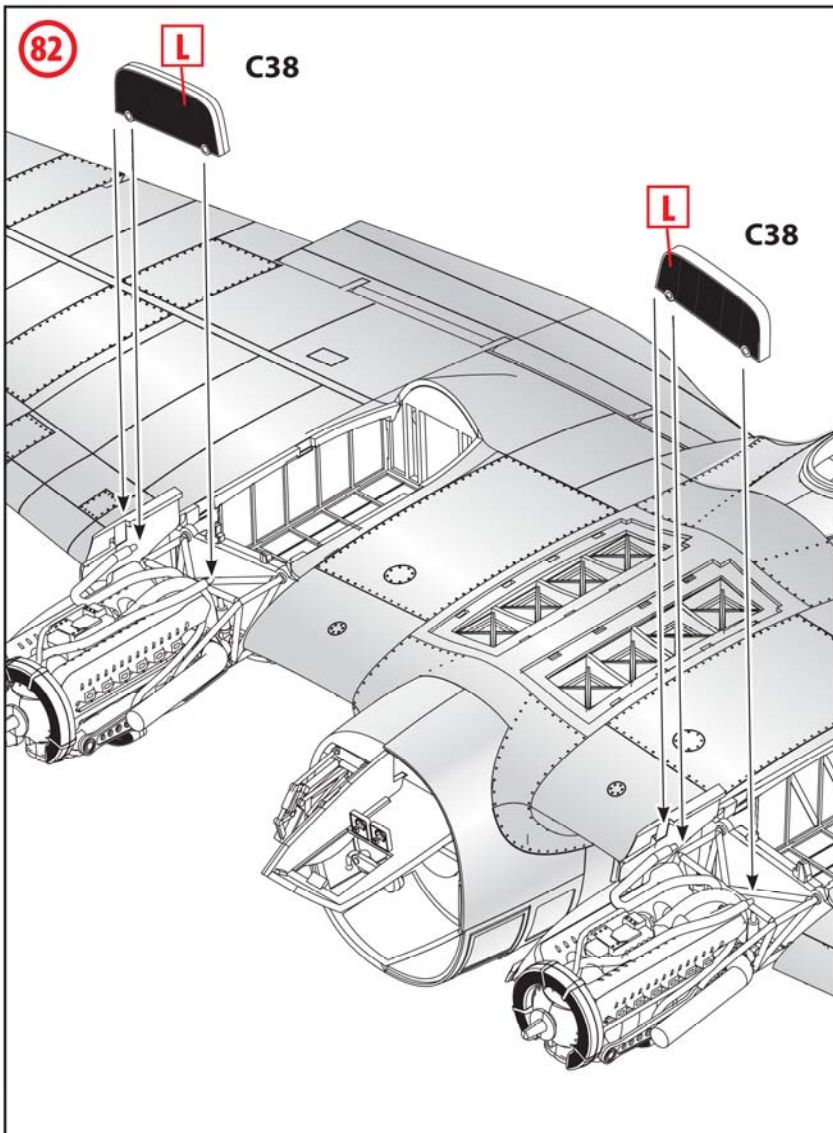
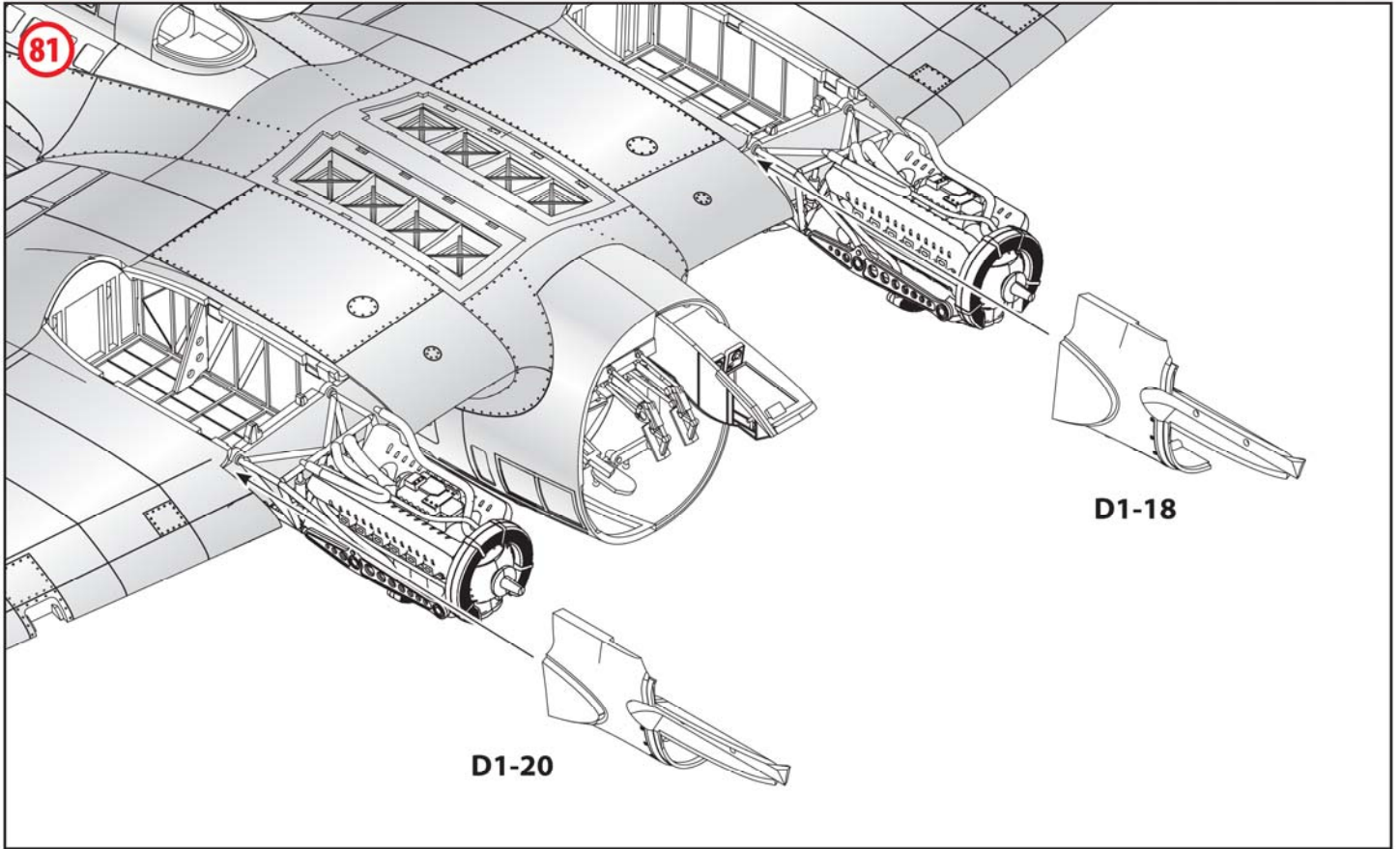

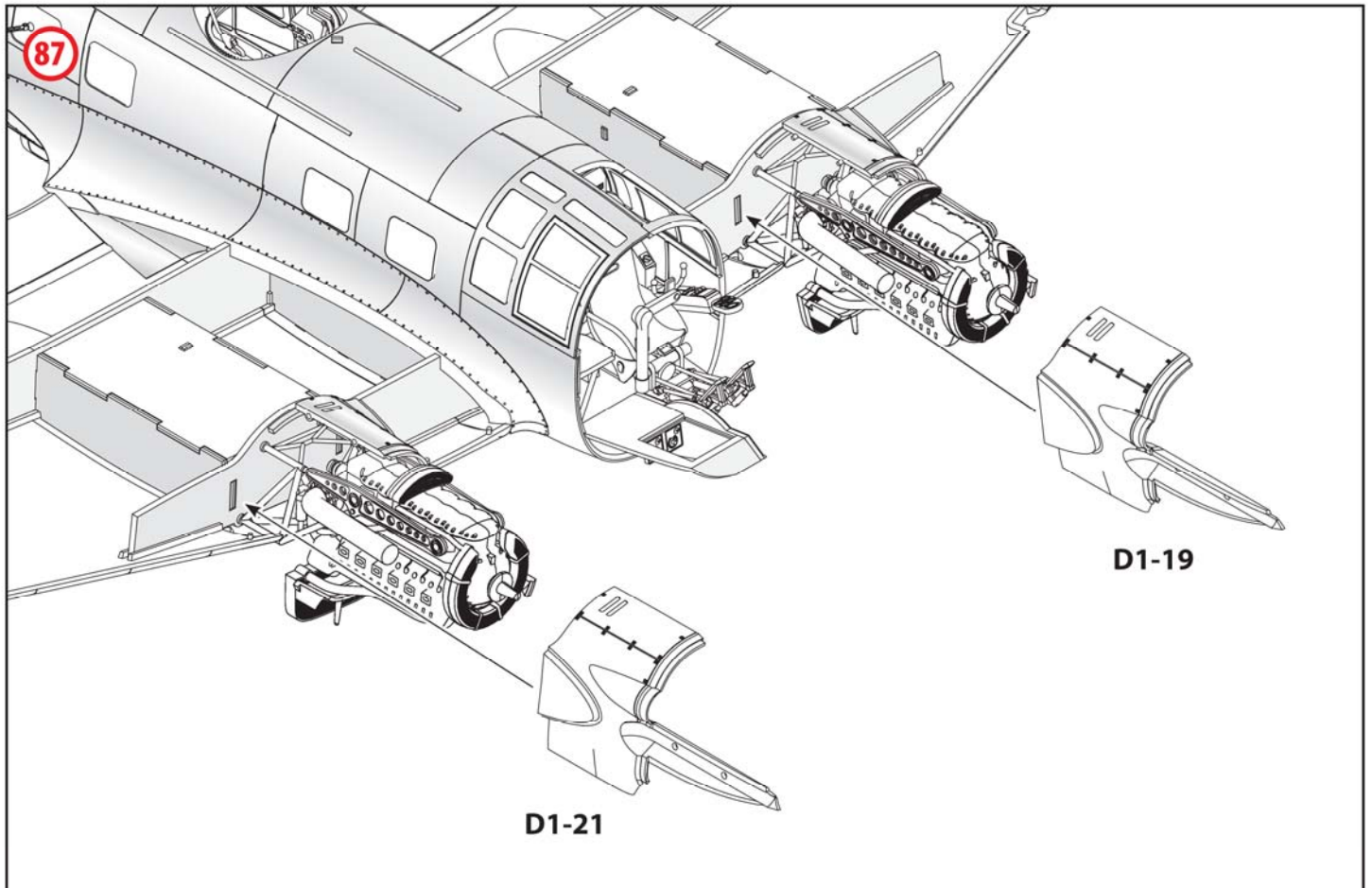
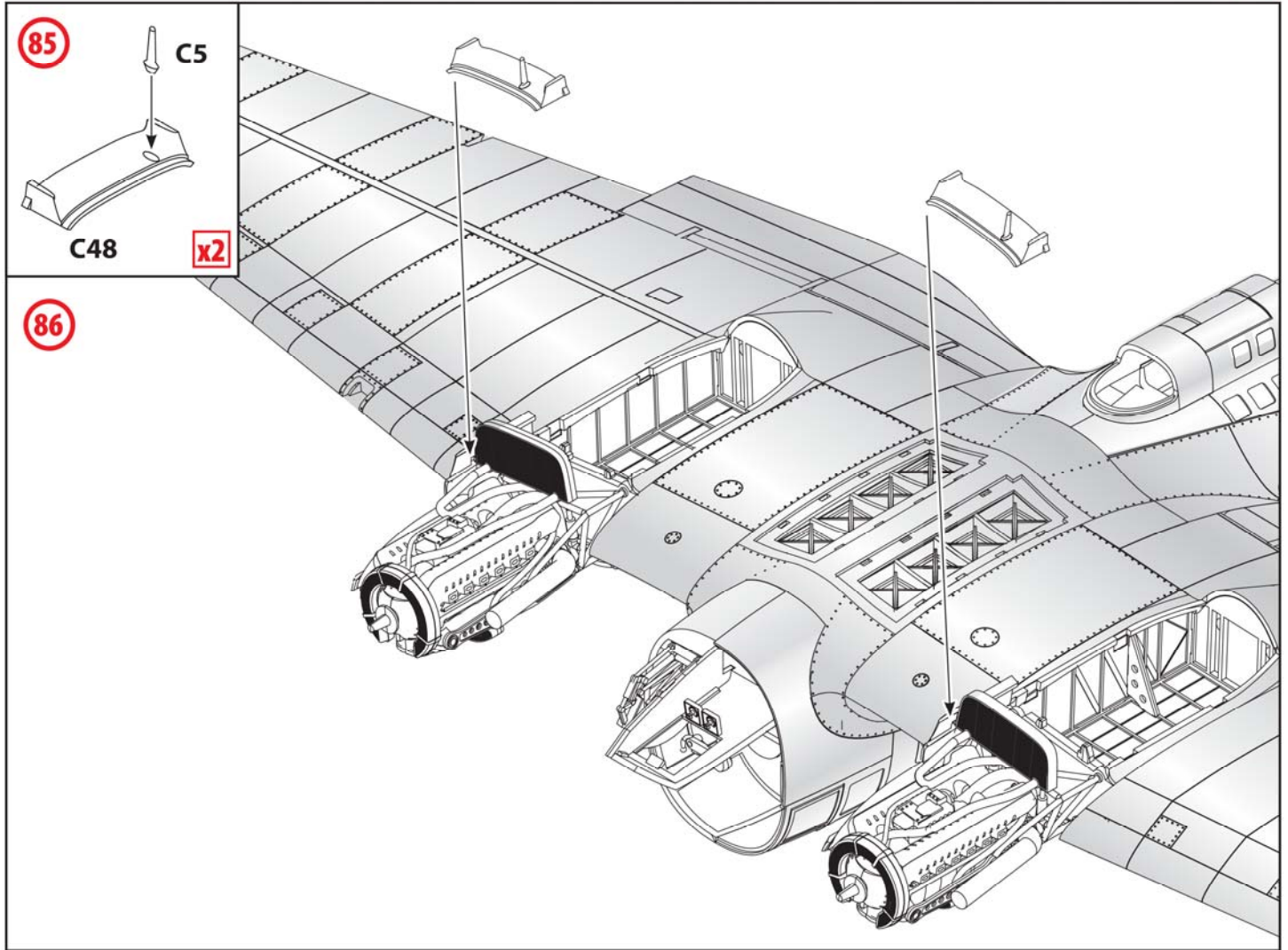

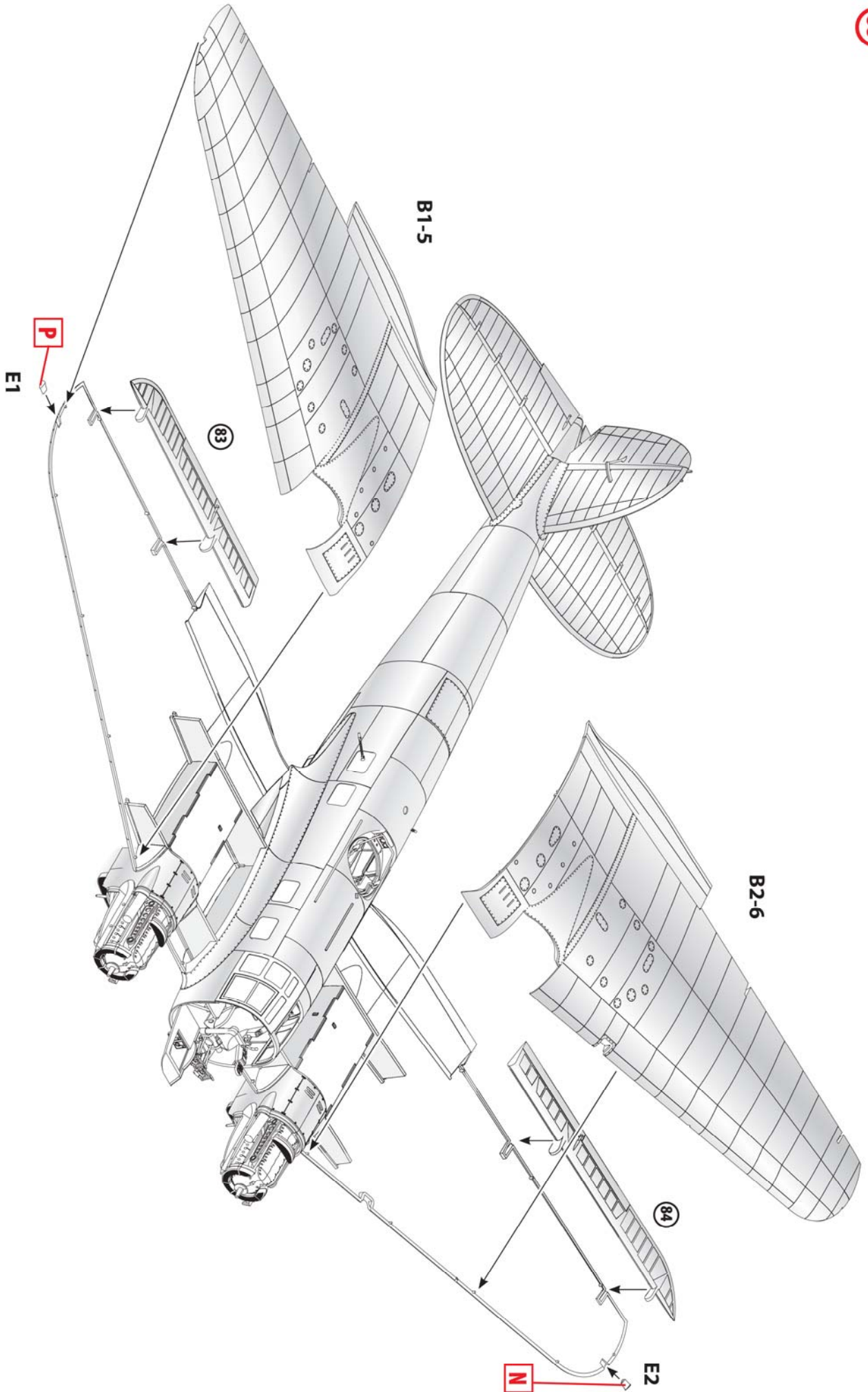

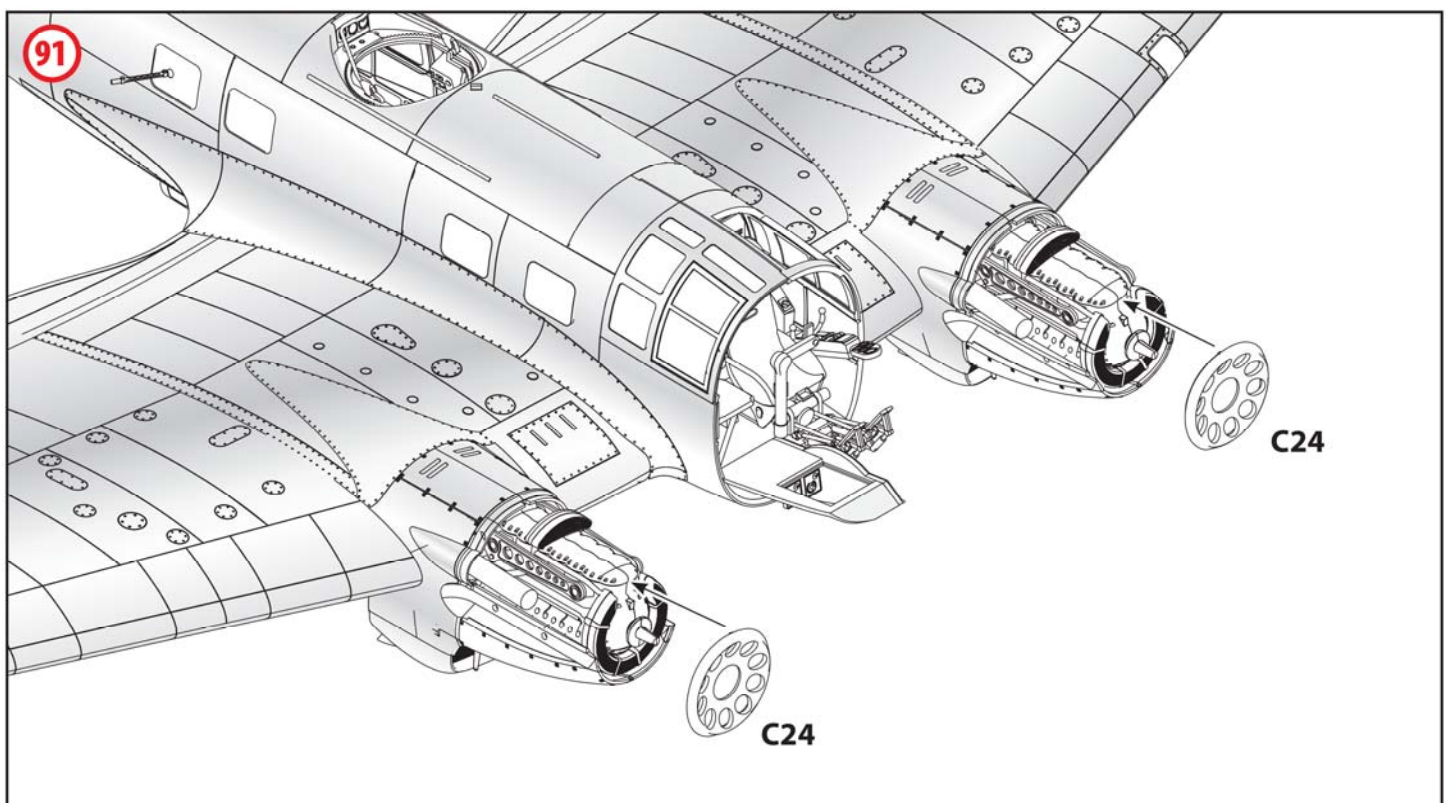
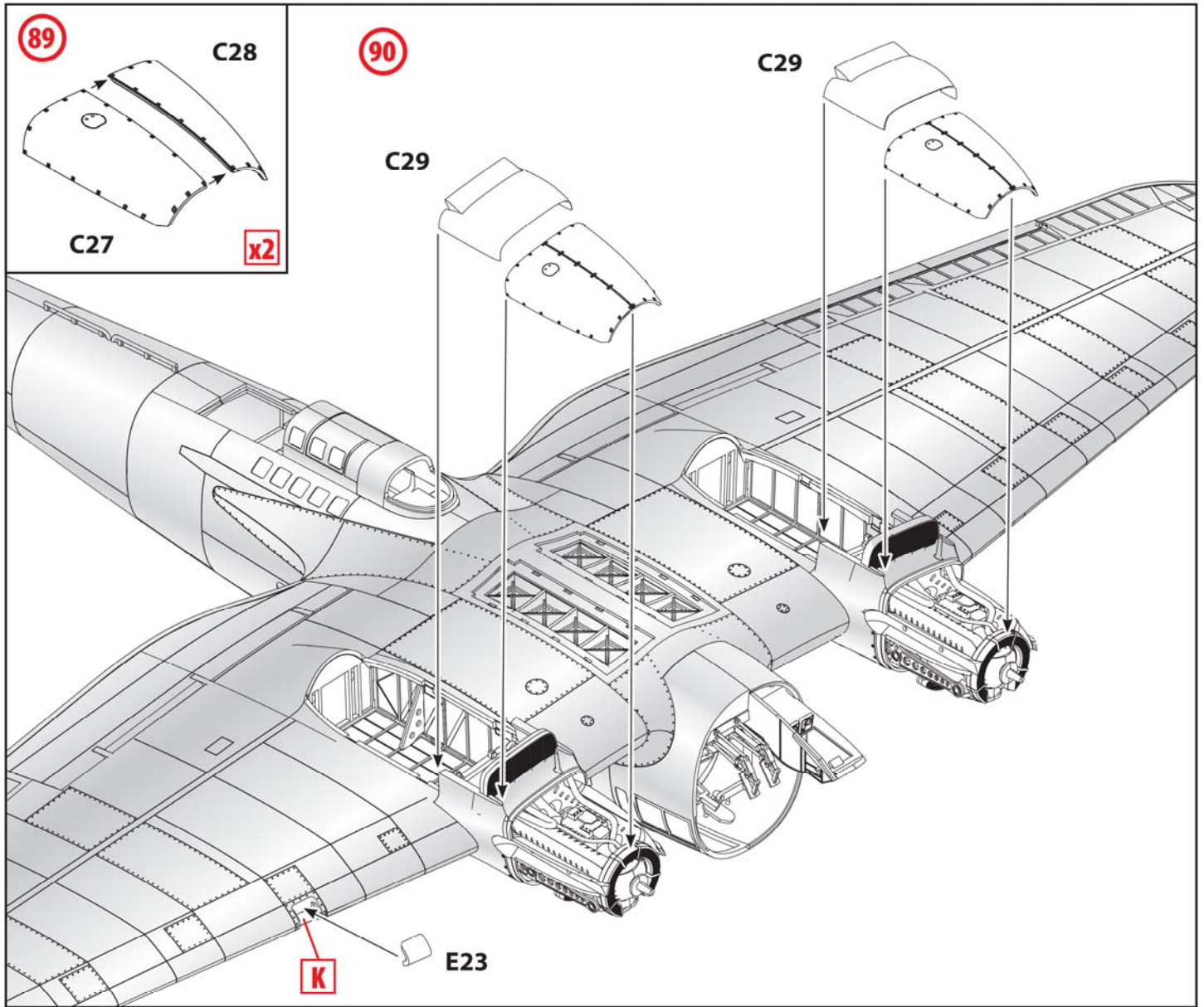

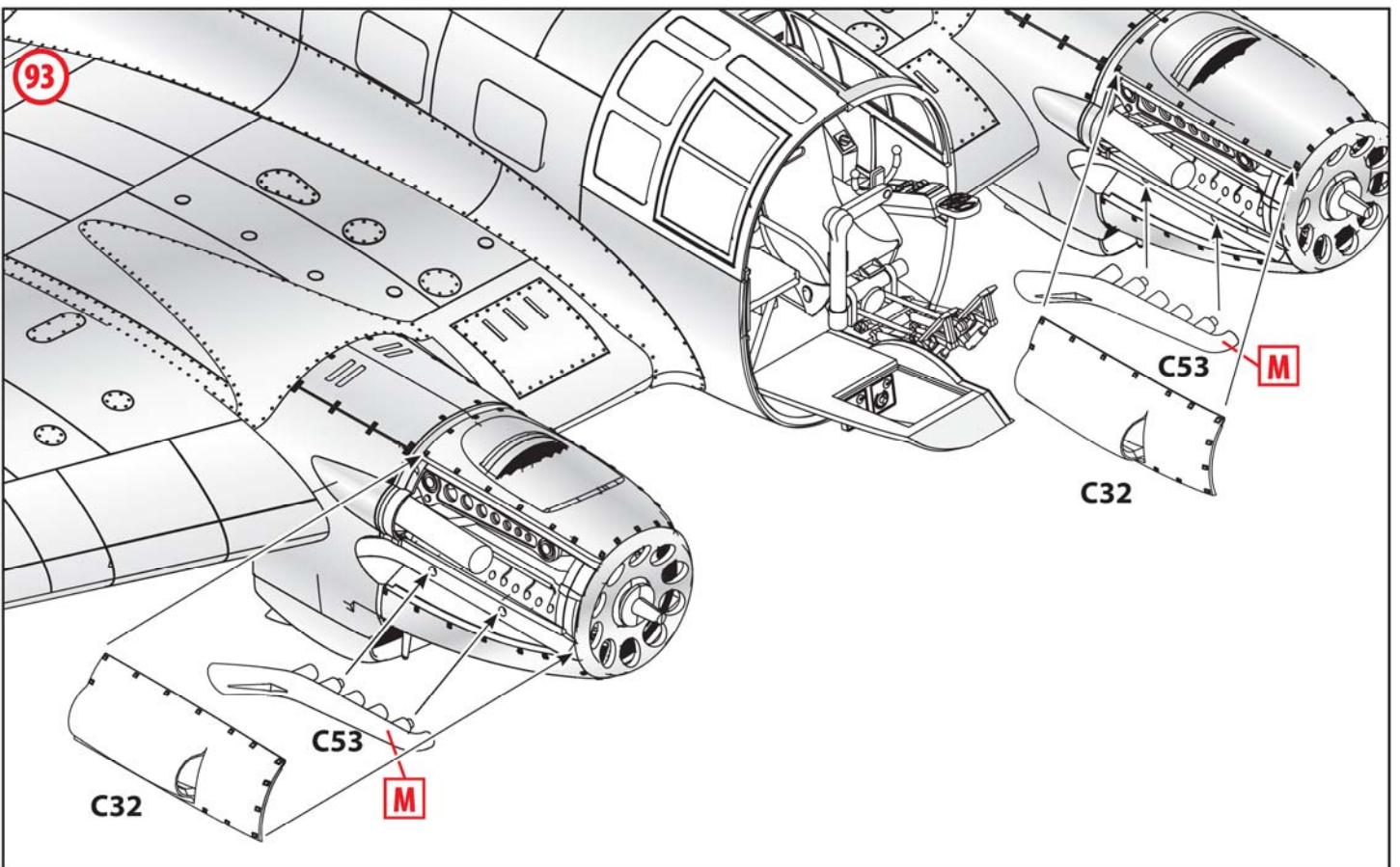
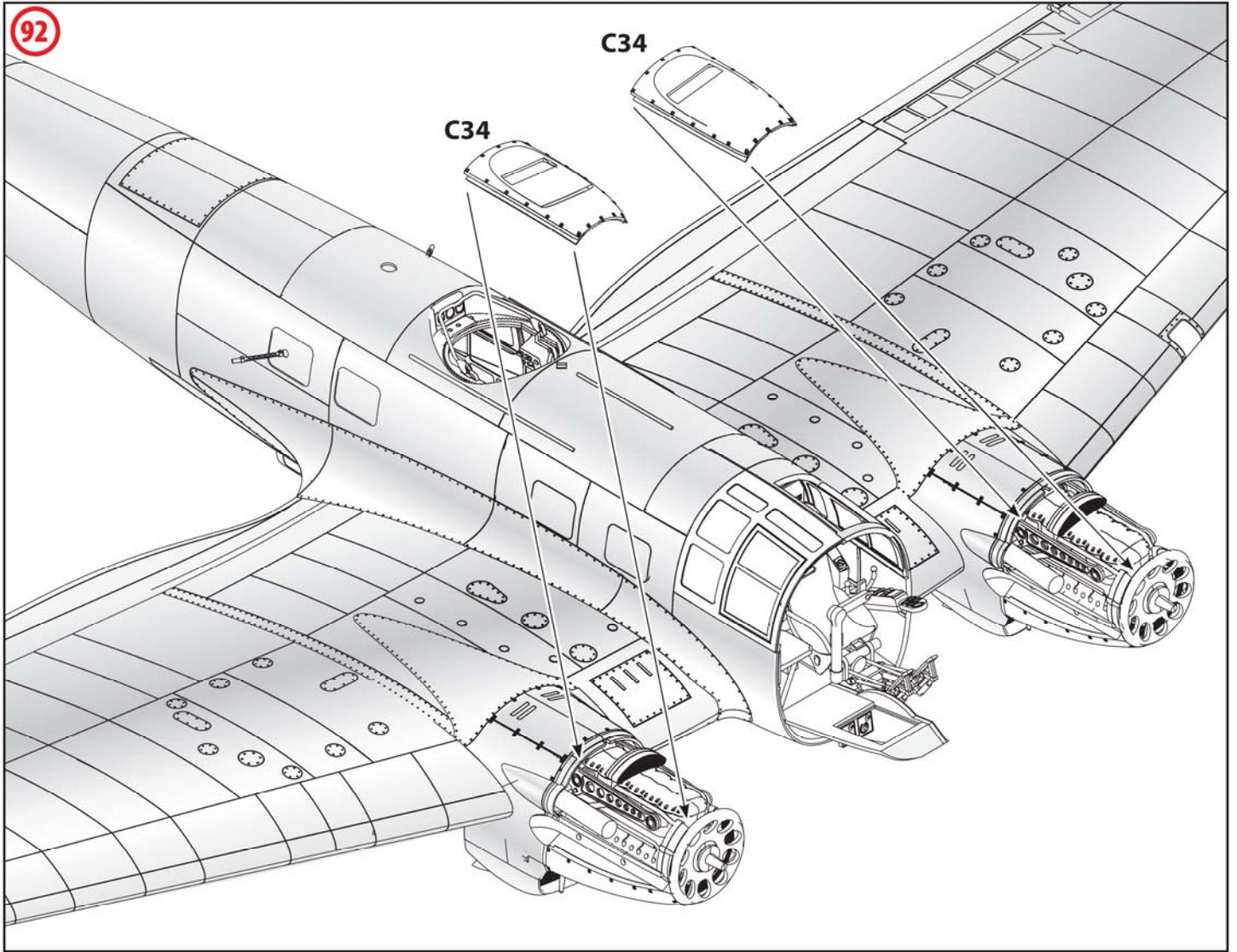

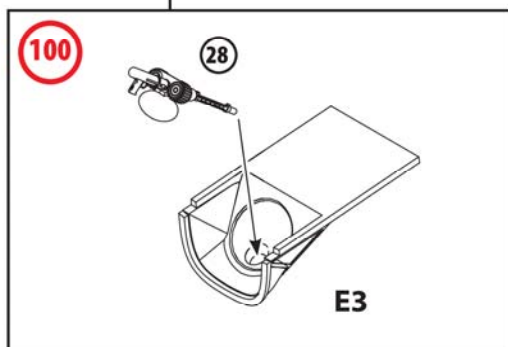
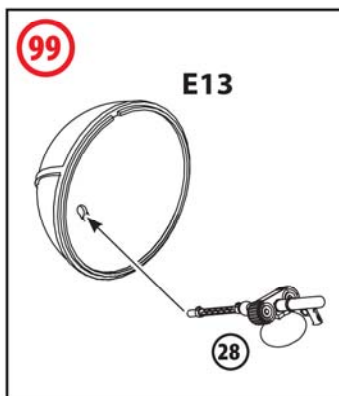
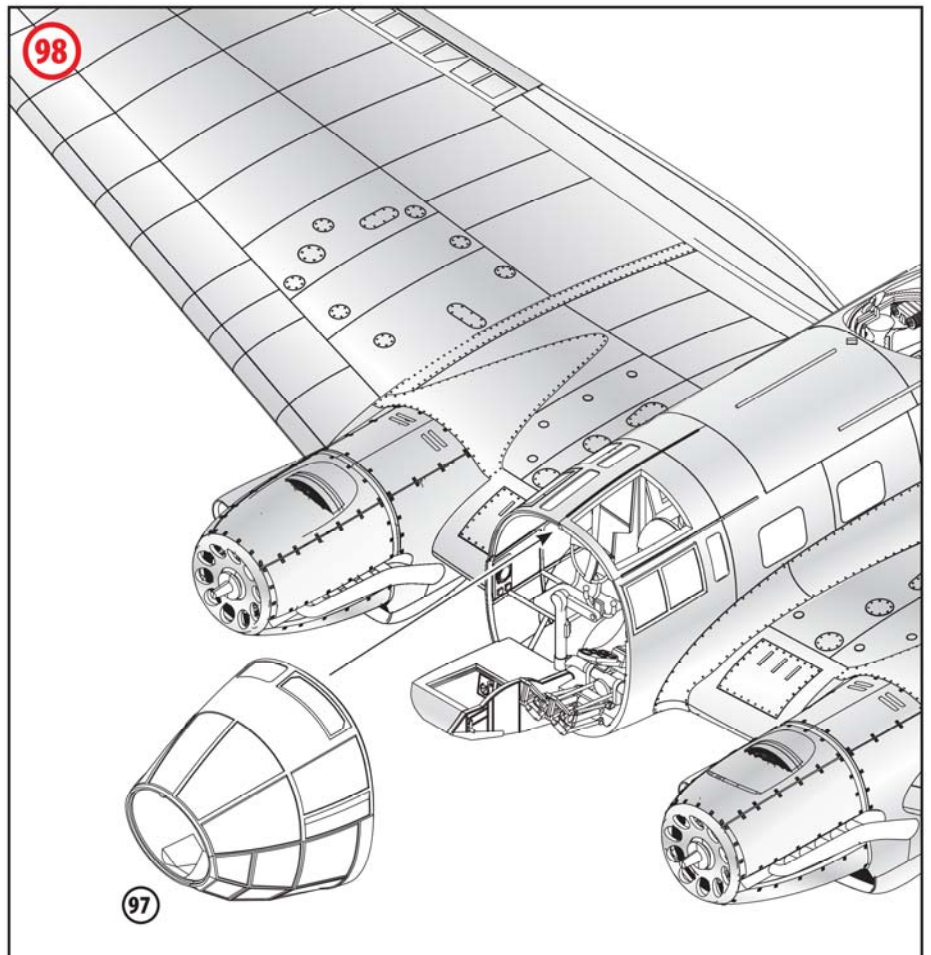
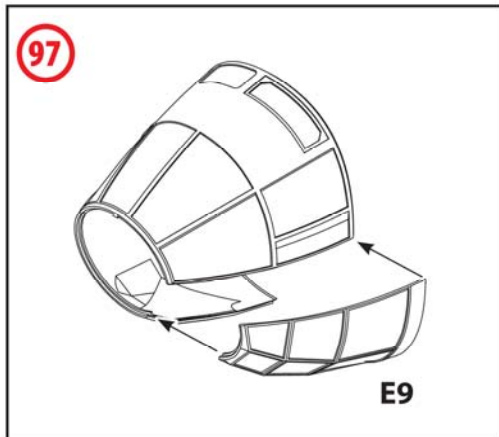
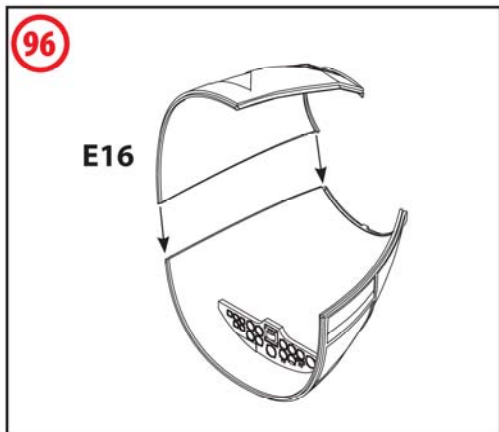
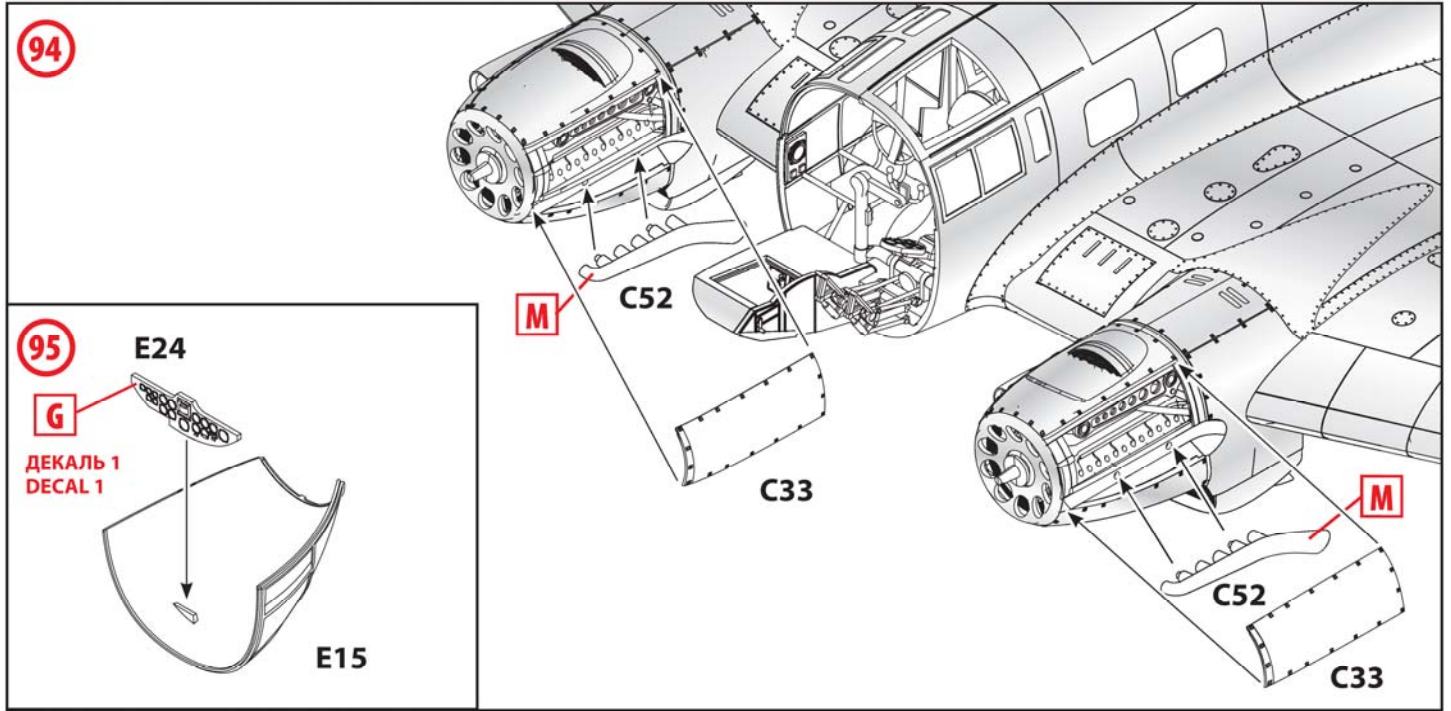

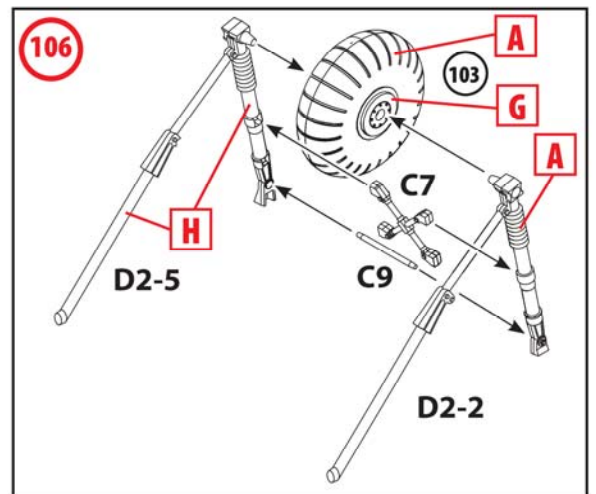
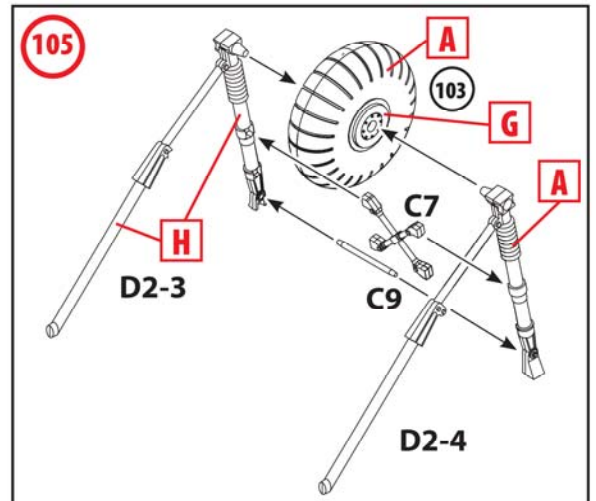
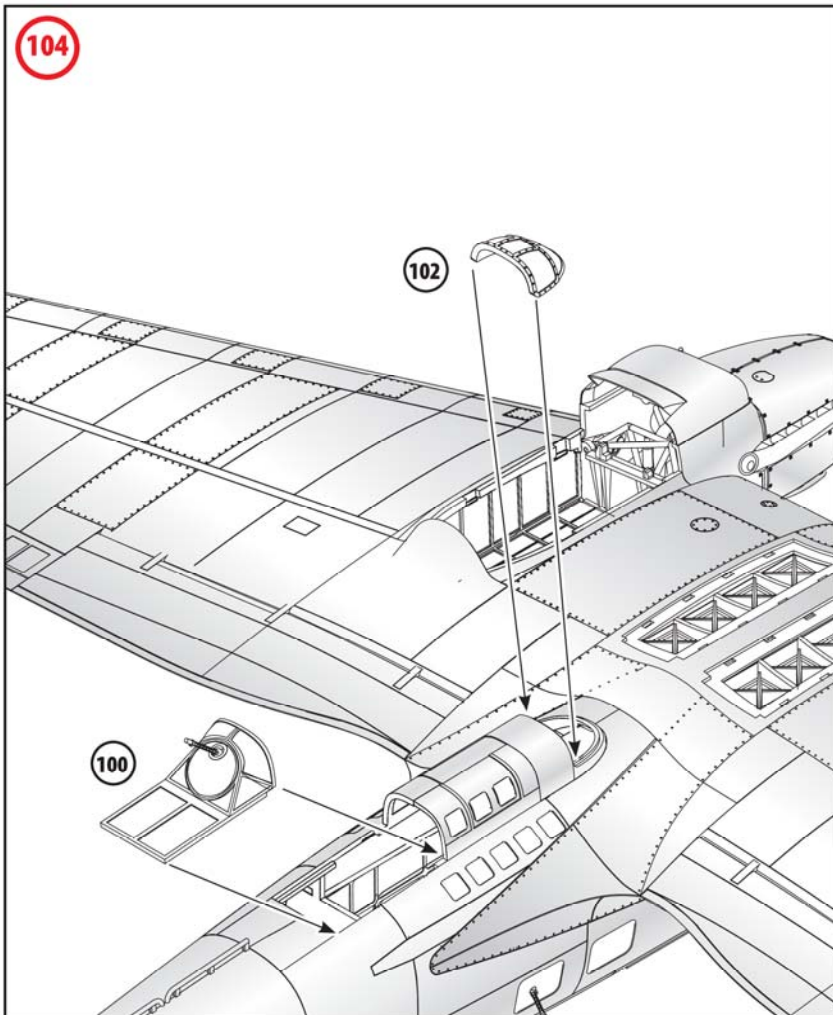
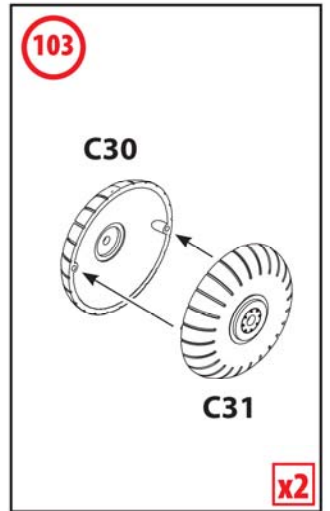
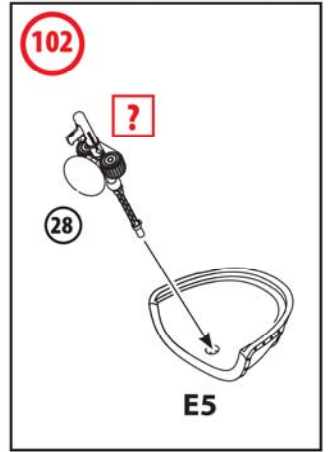
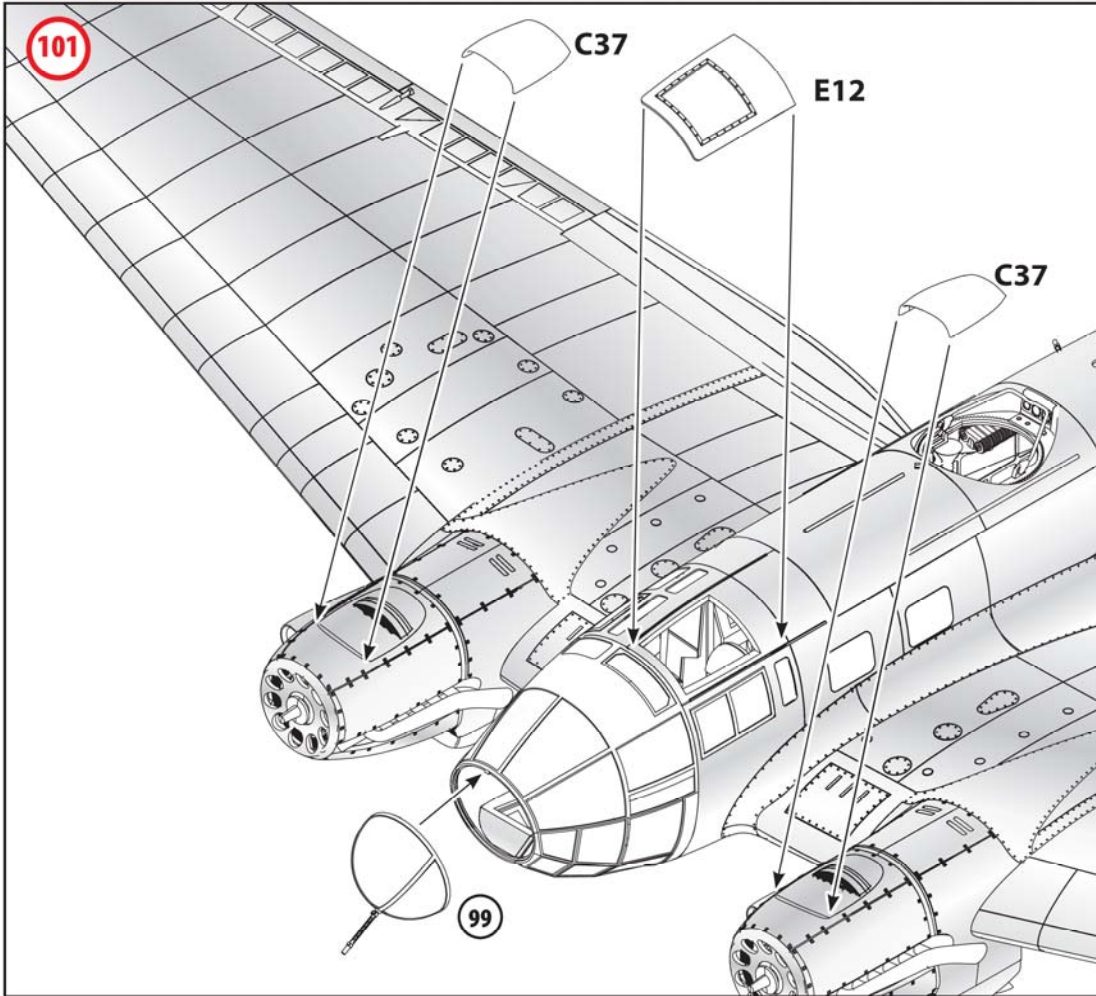

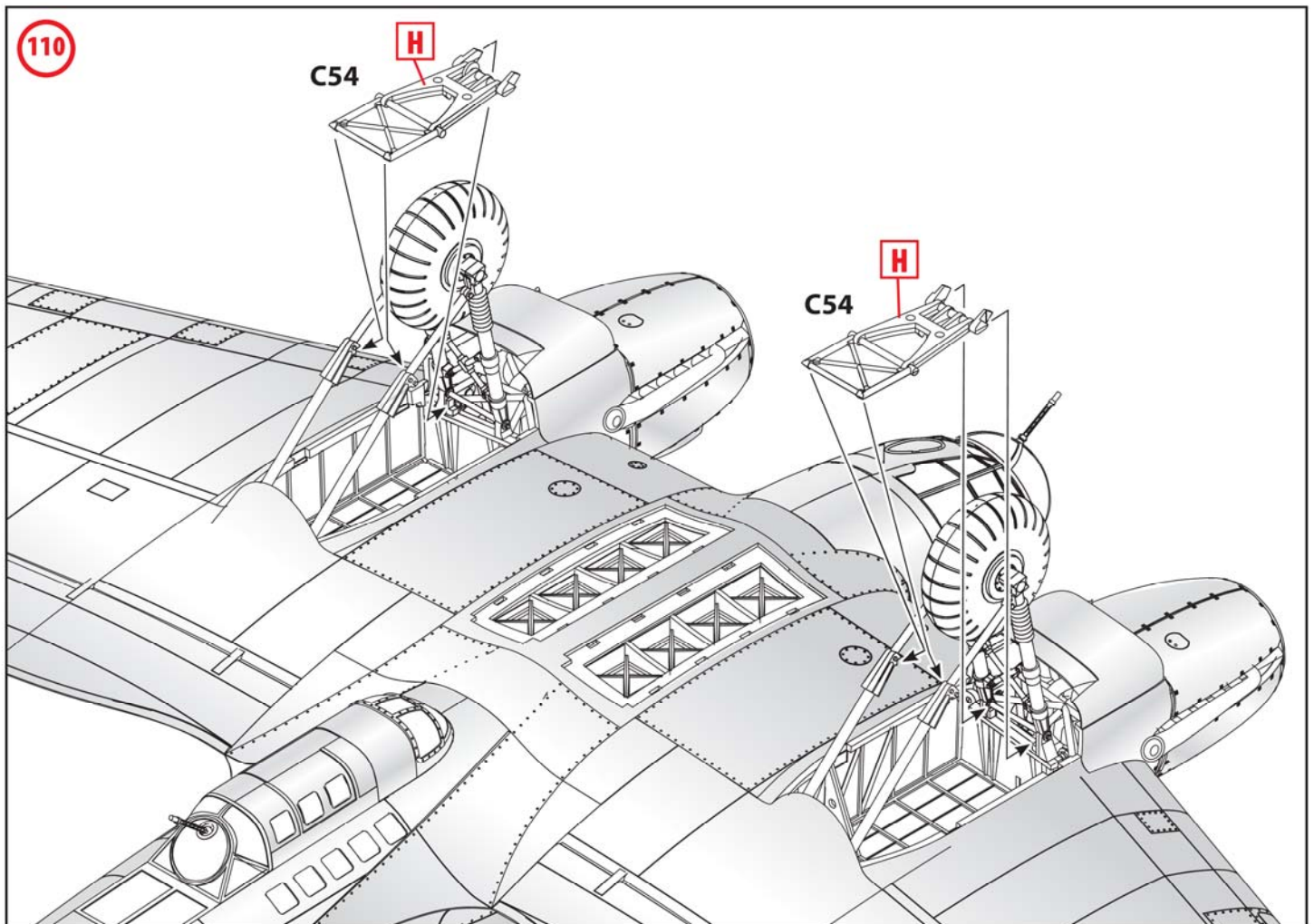
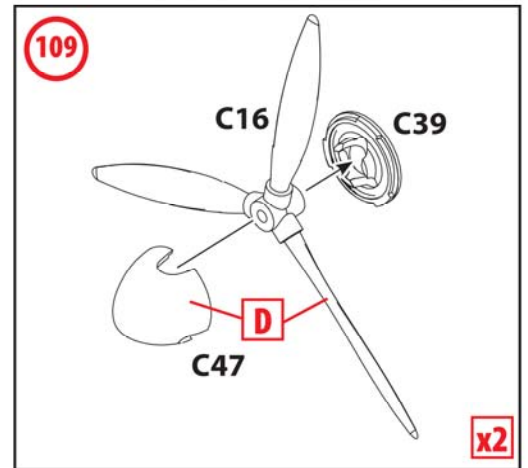
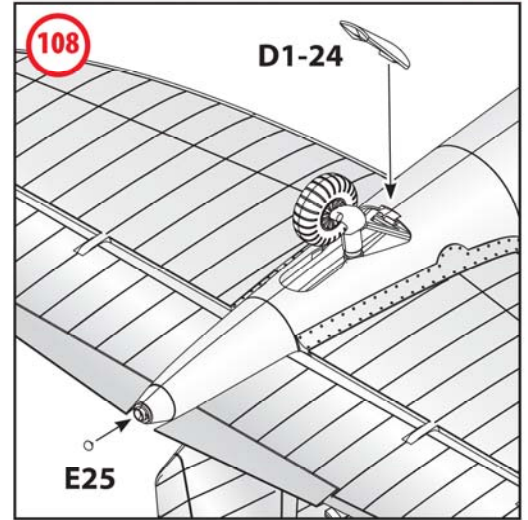
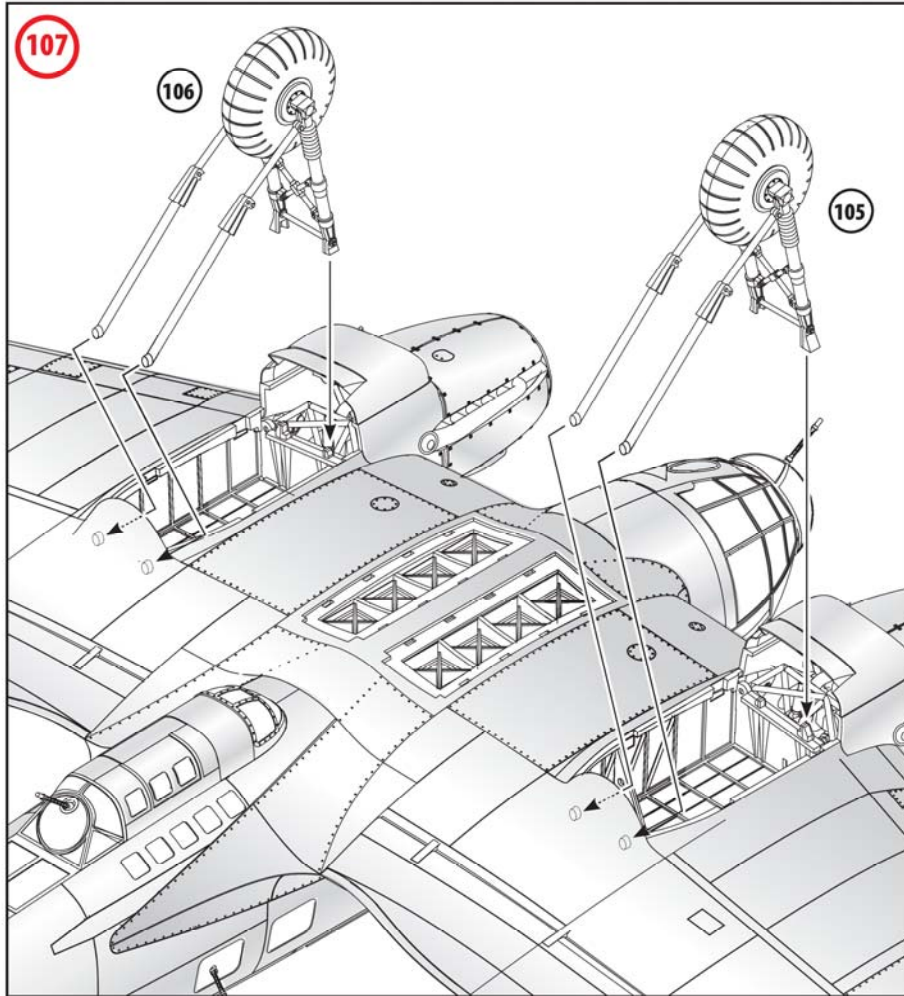

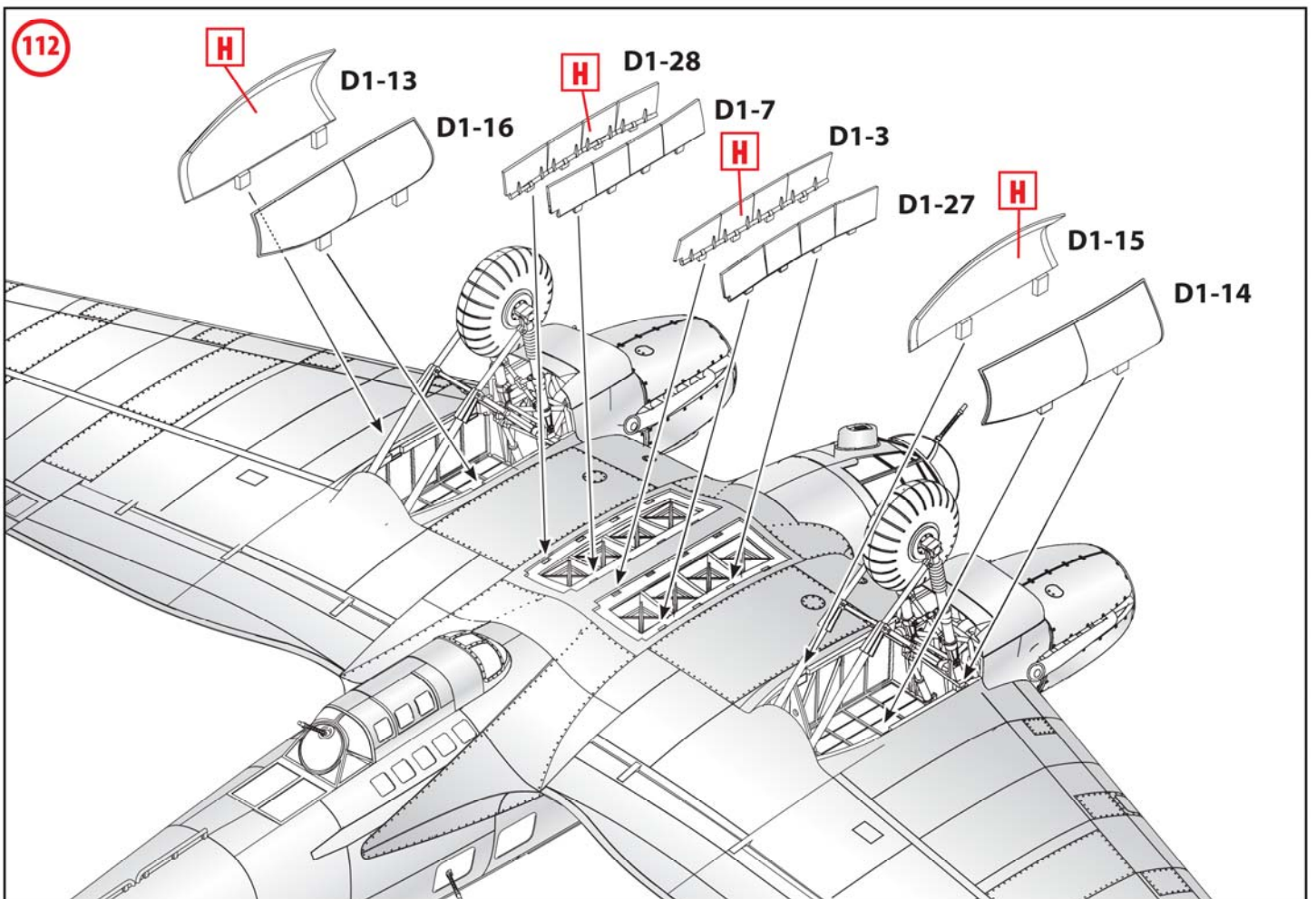
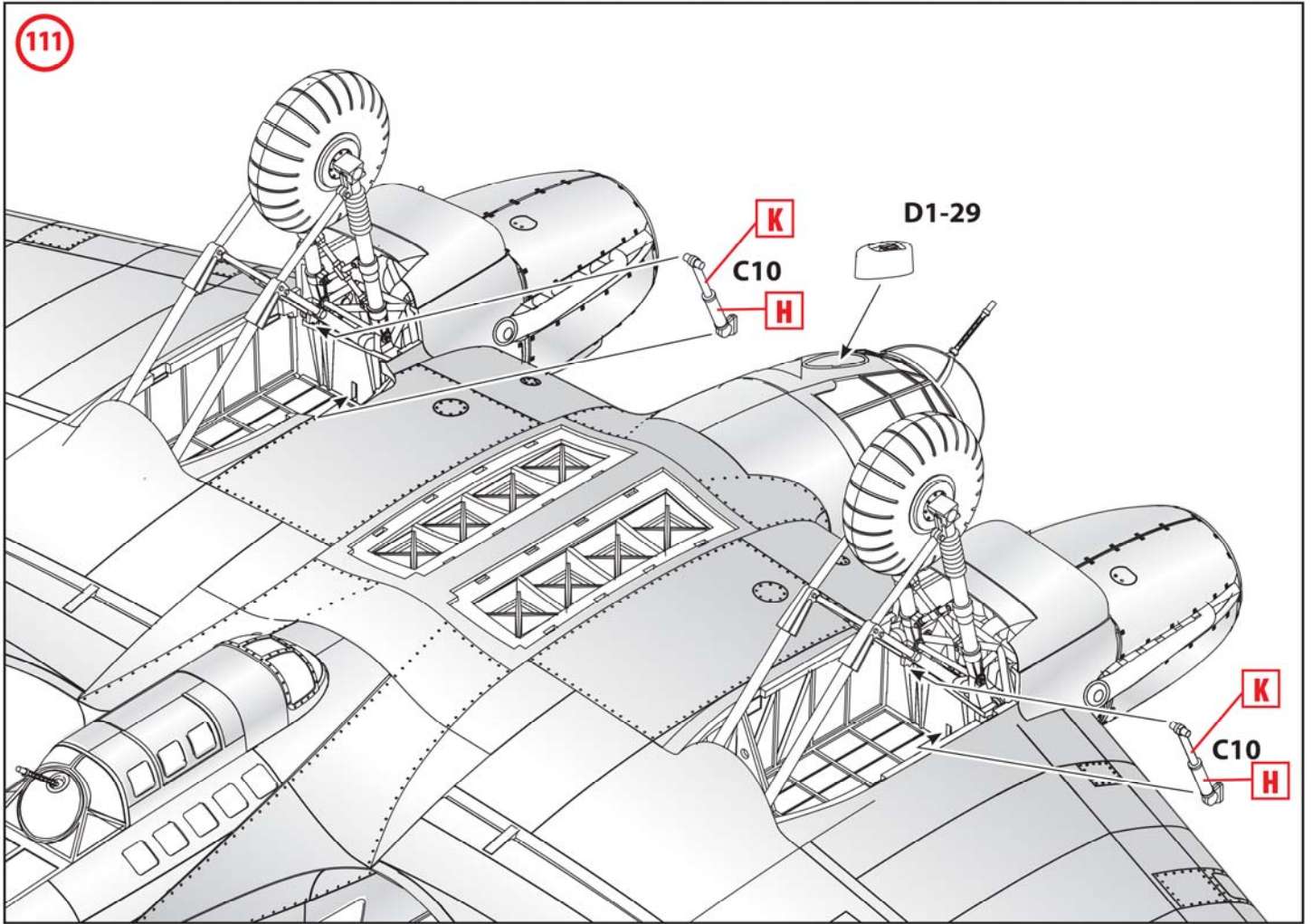

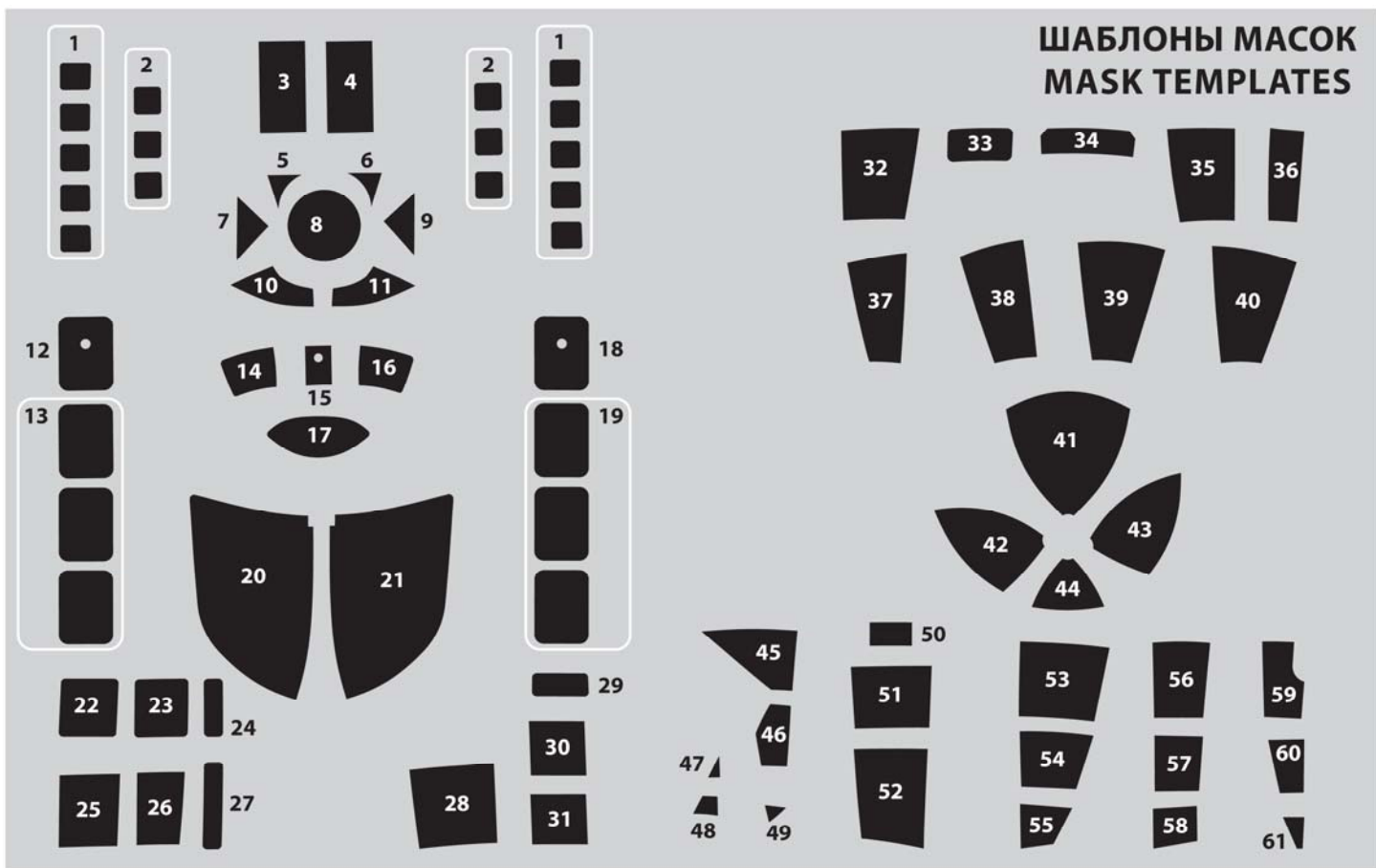
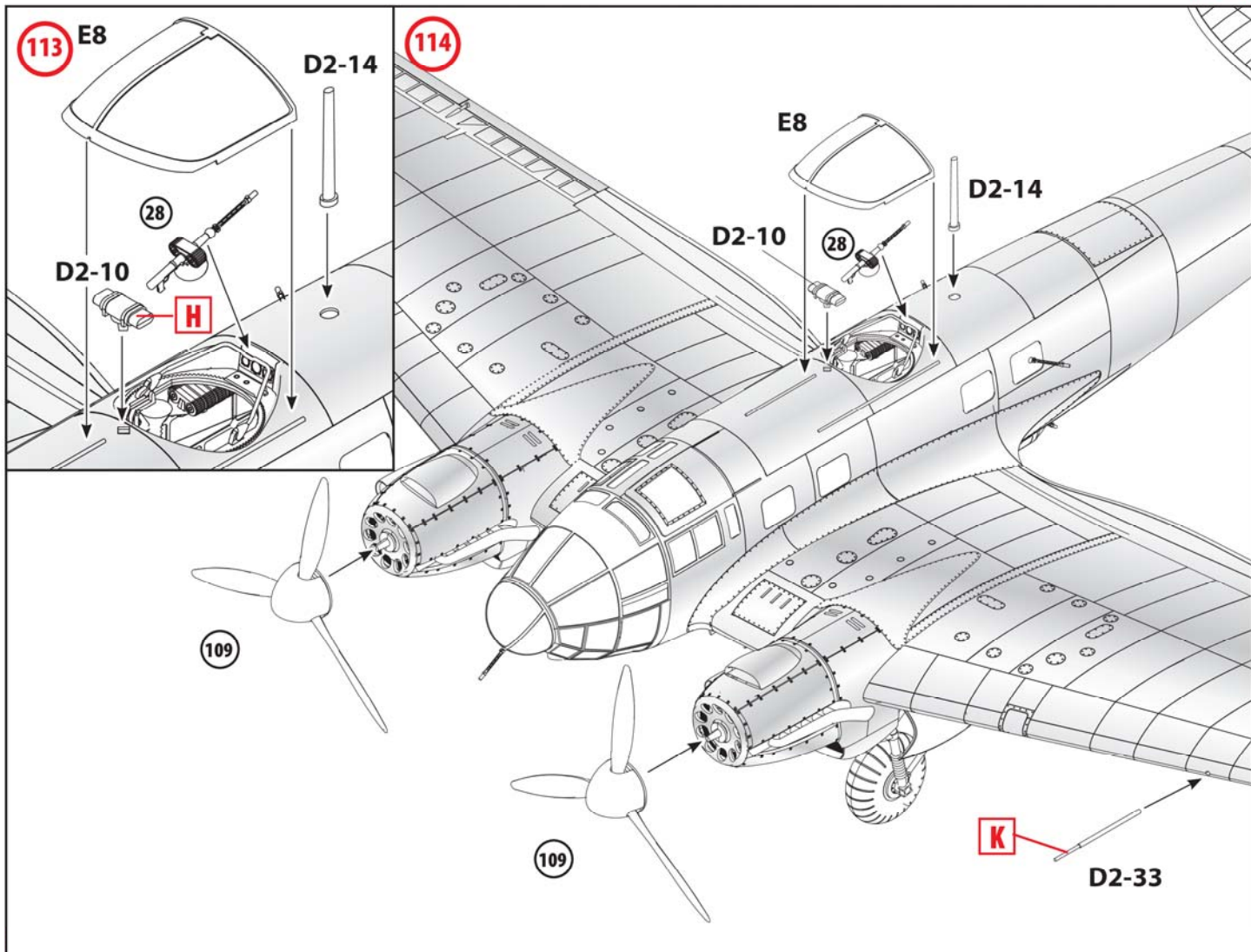

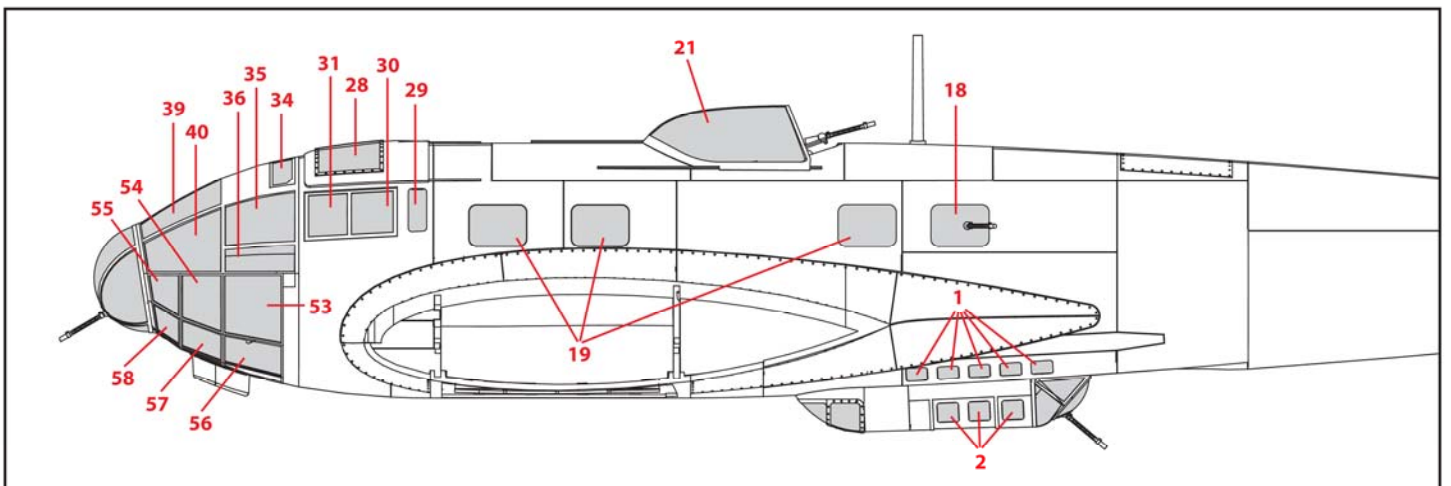
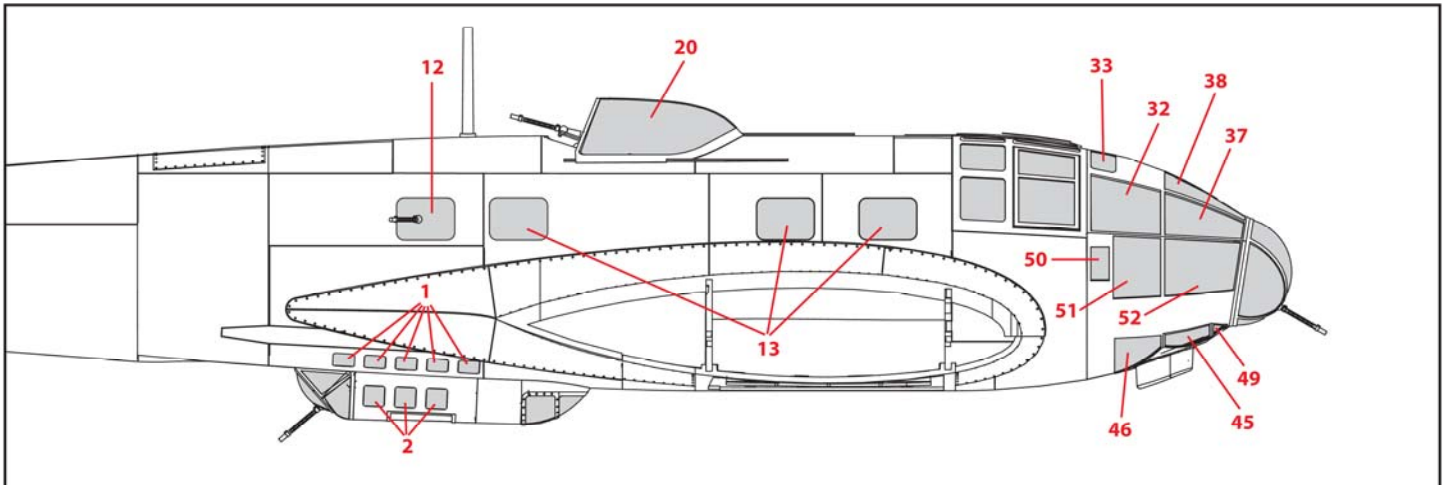
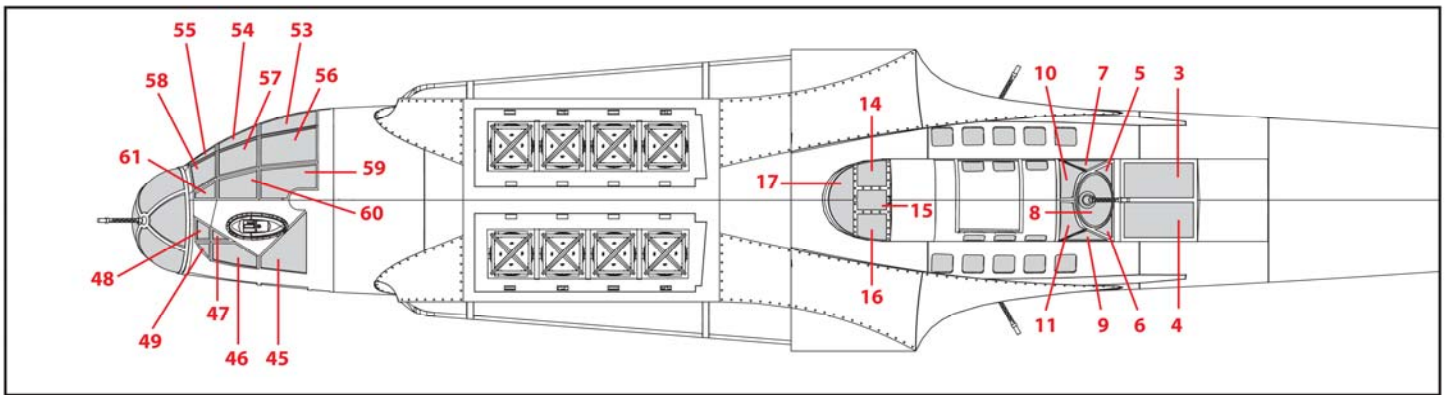
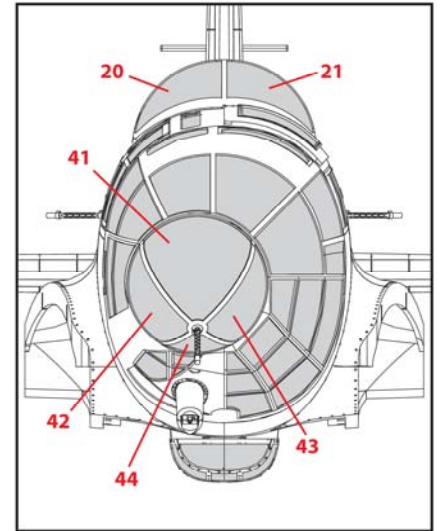
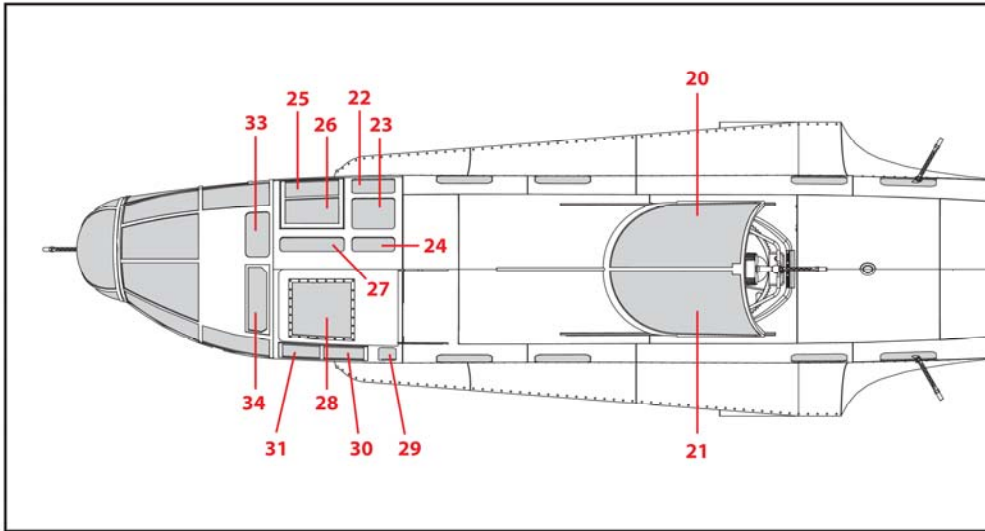

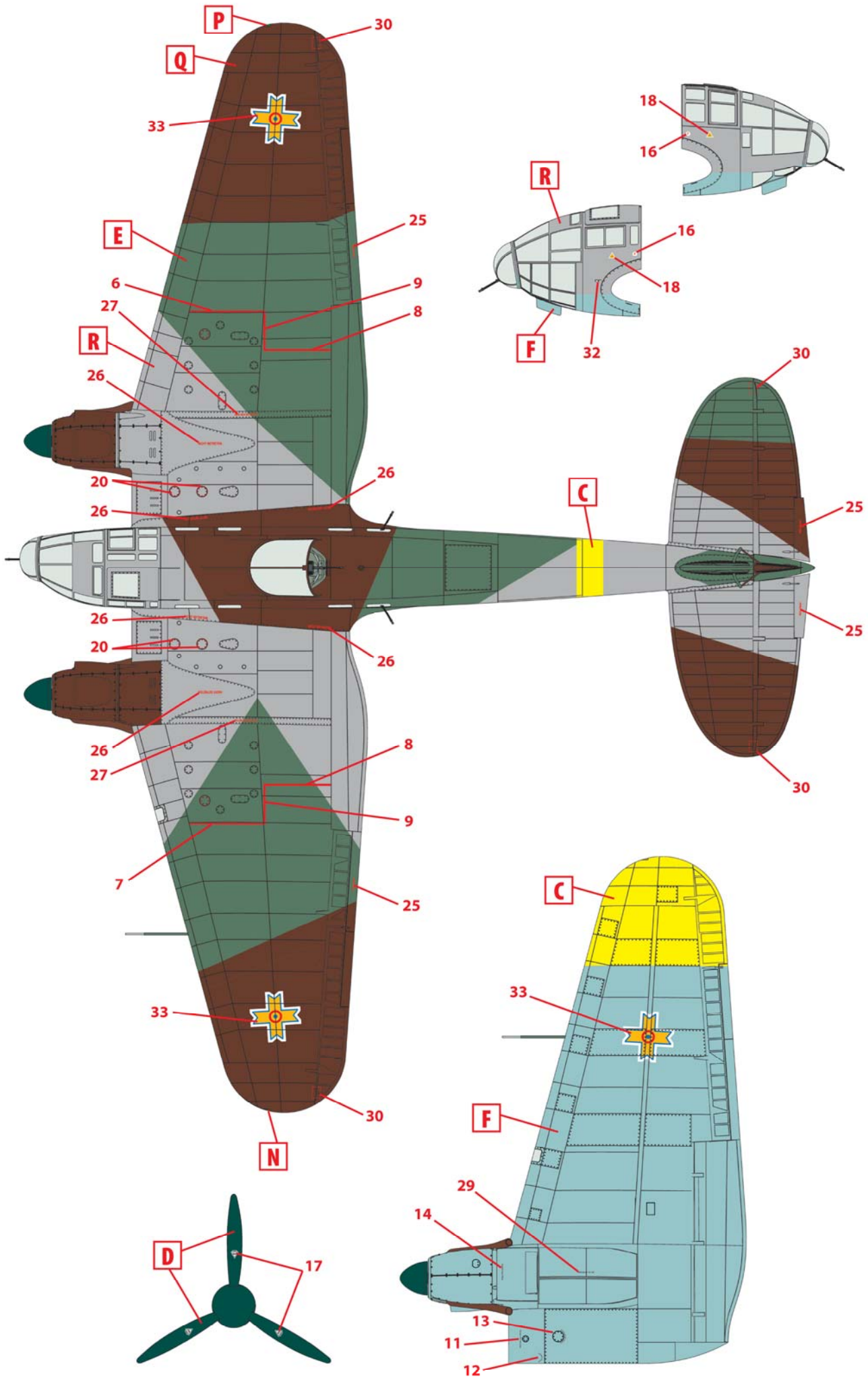

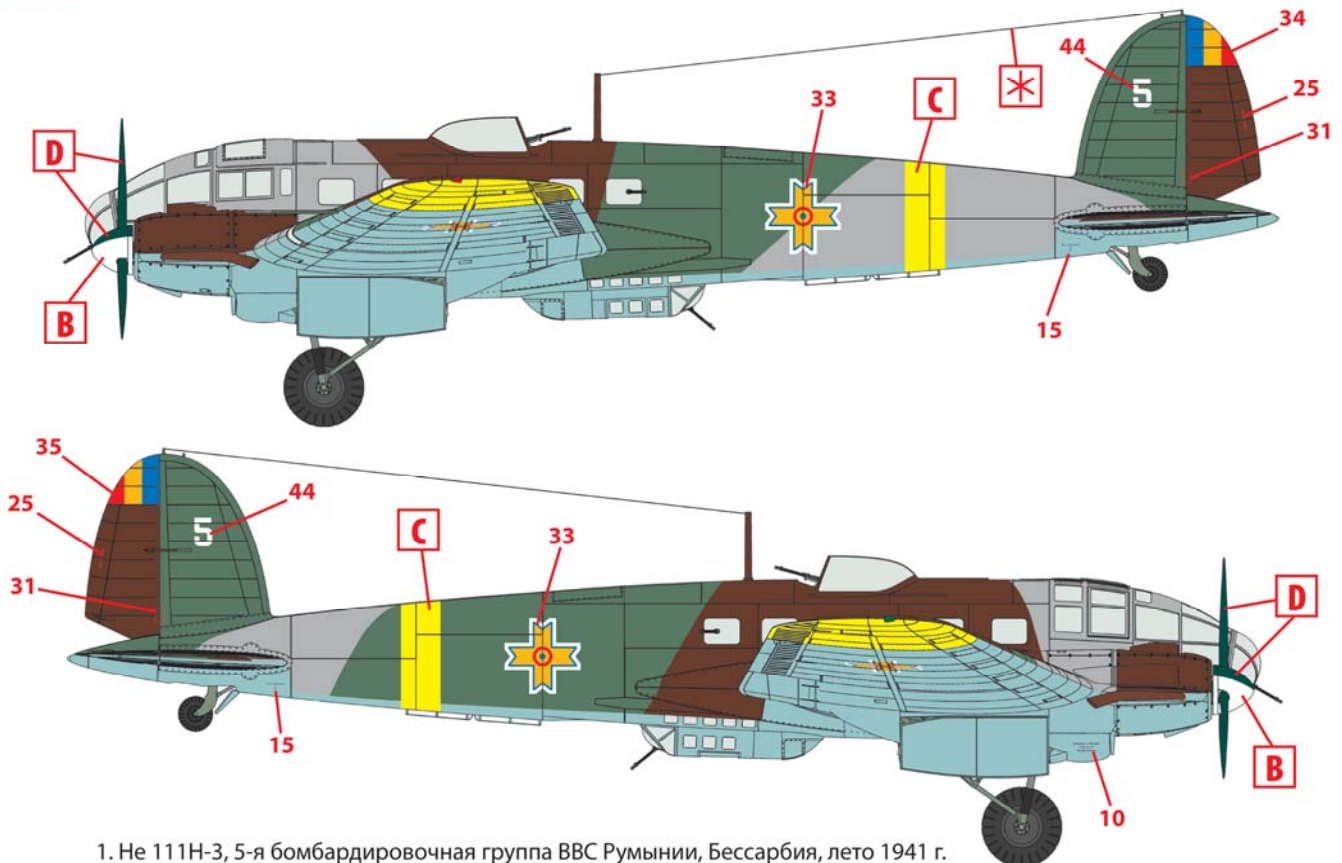

1. He 111H-3, 5-я бомбардировочная группа ВВС Румынии, Бессарбия, лето 1941 г.
 He 111H-3, 5th Bomber Group, Romanian Air Force, Bessarabia, Summer 1941

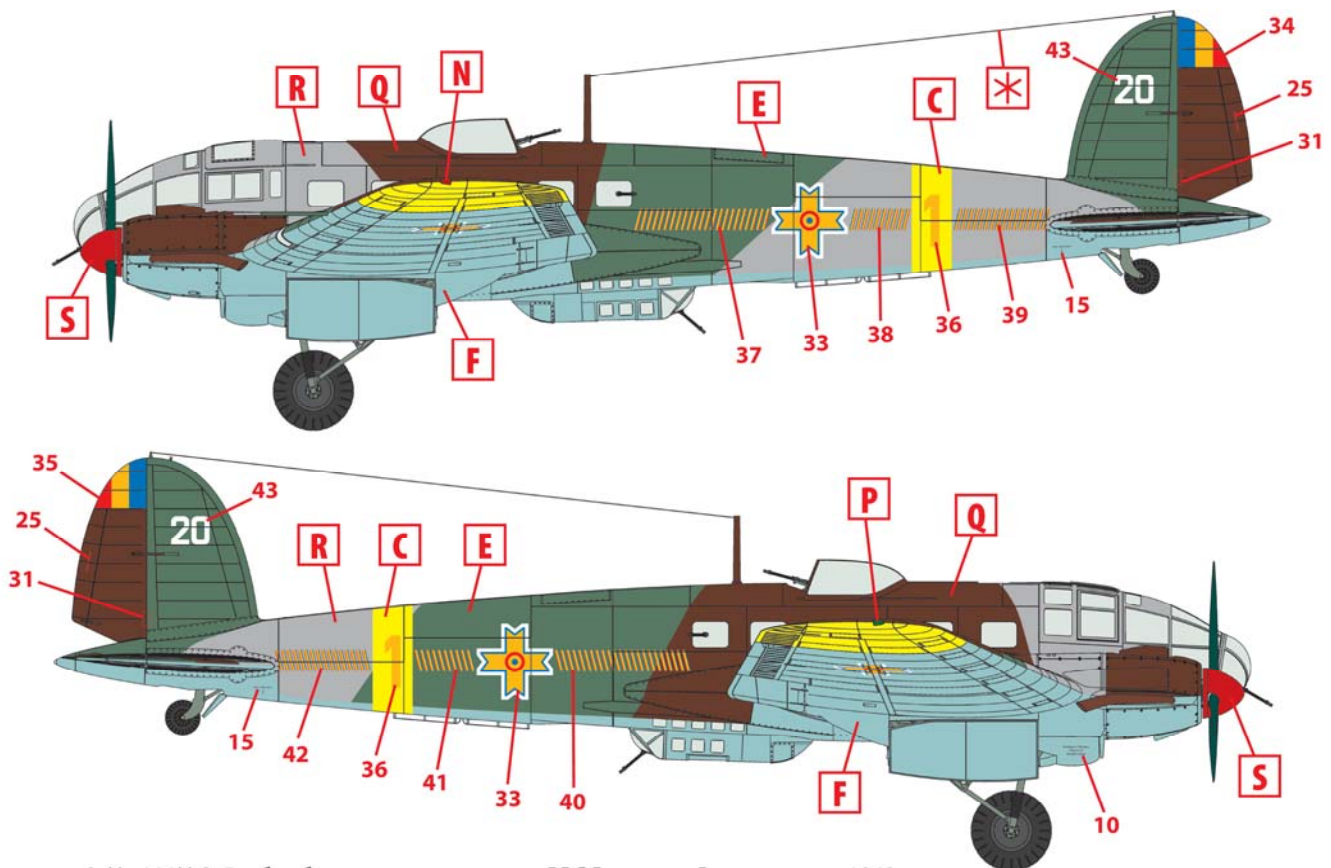

2. He 111H-3, 5-я бомбардировочная группа ВВС Румынии, Россия, конец 1942 г.
 He 111H-3, 5th Bomber Group, Romanian Air Force, Russia, late 1942