

G.W.H.[®]
LIMITED EDITION

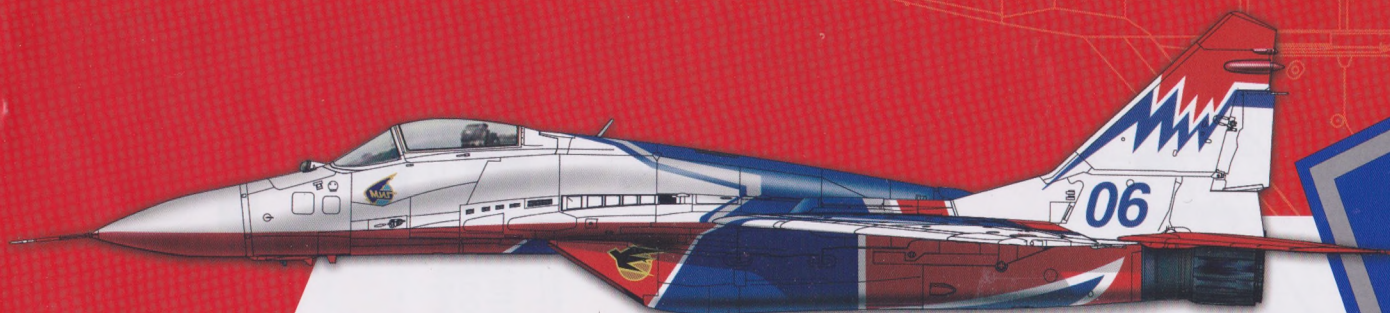

RUSSIAN SWIFTS

MiG-29 9-13 "FULCRUM C" "支点C" 俄罗斯两燕表演队涂装限量版



1/48
SCALE **S4814**

A Parts x 1

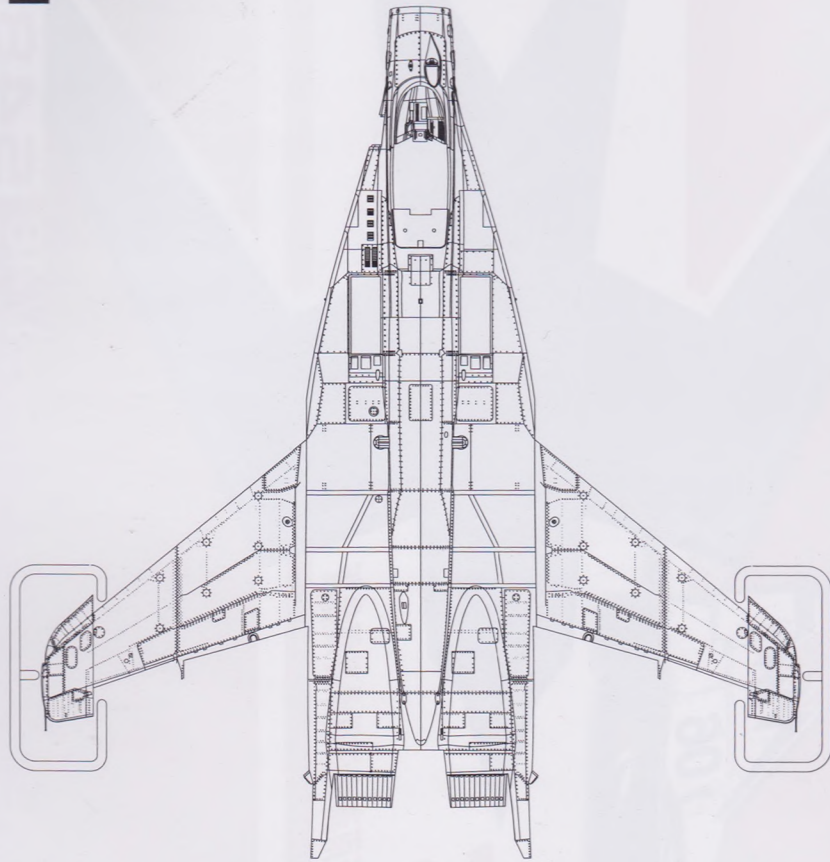

B Parts x 1

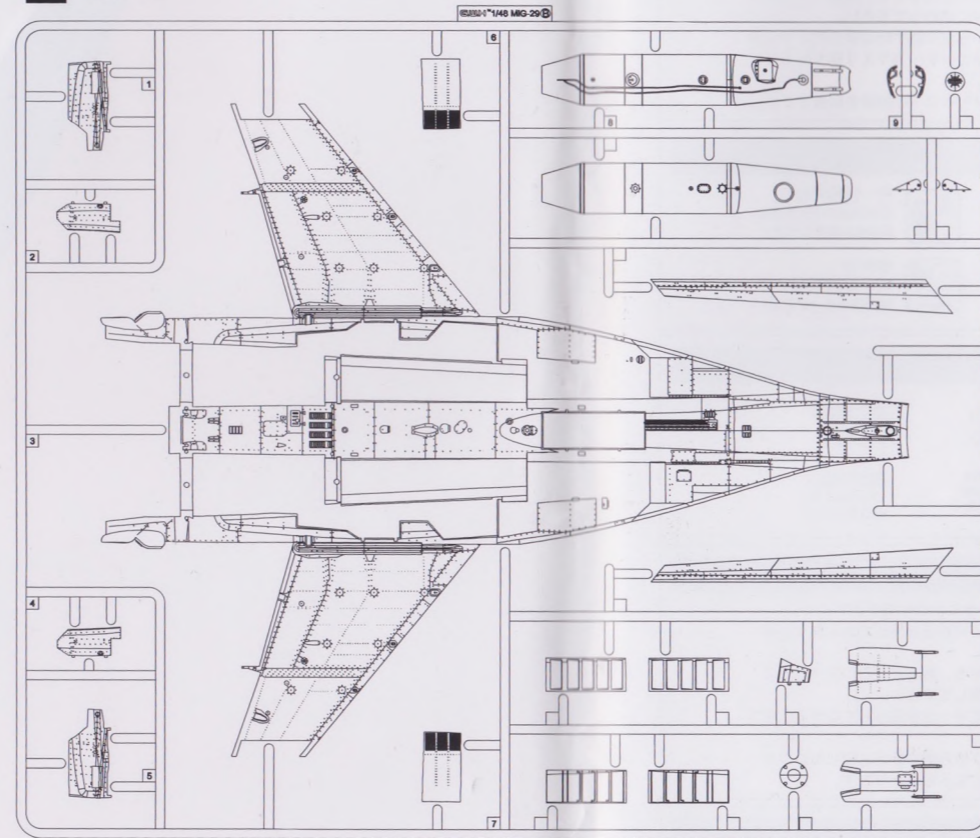

C Parts x 1

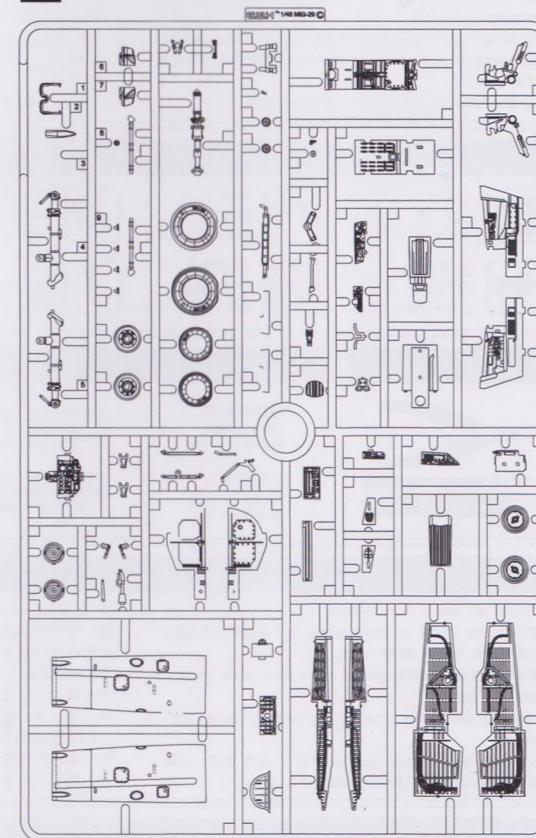

H Parts x 1

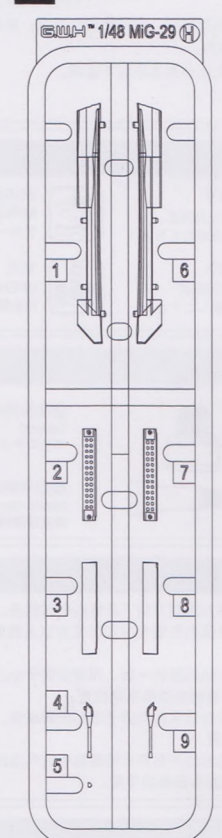

D Parts x 1

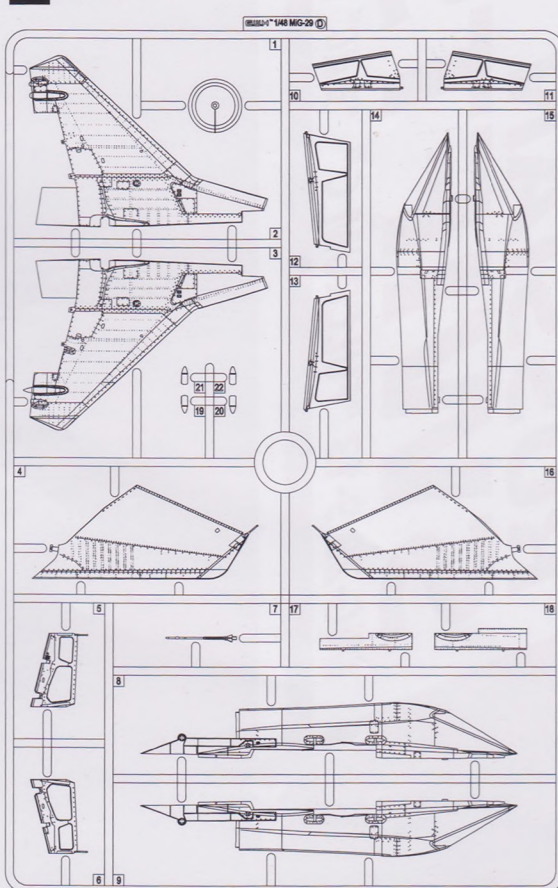

I Parts x 2

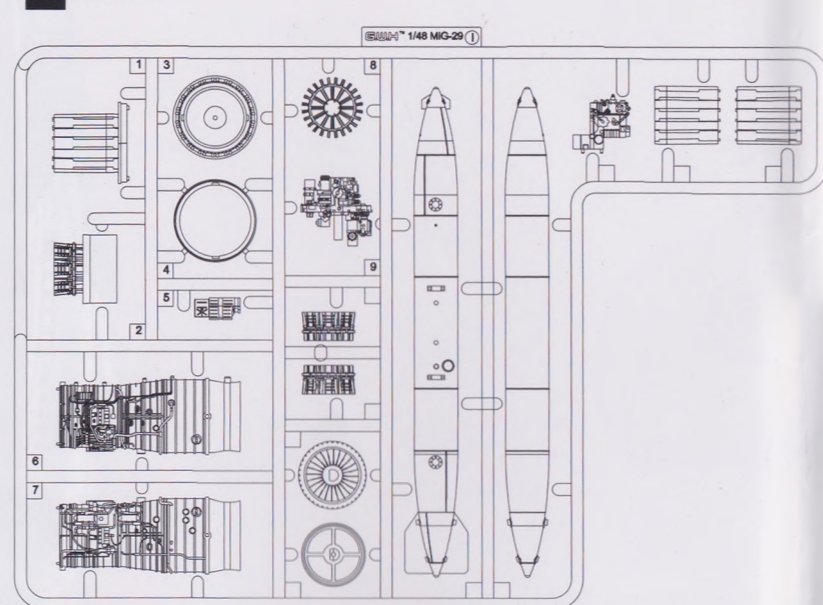

G Parts x 1

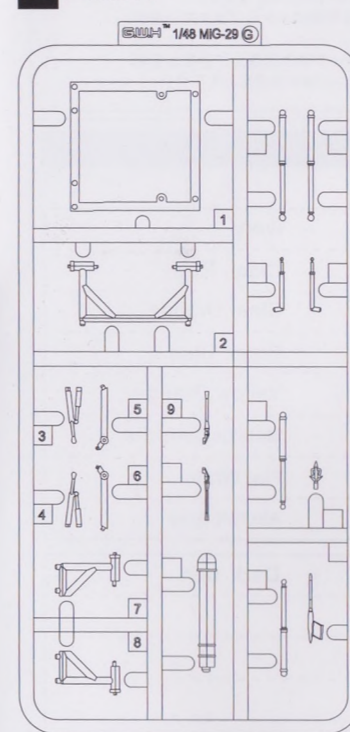

E Parts x 1

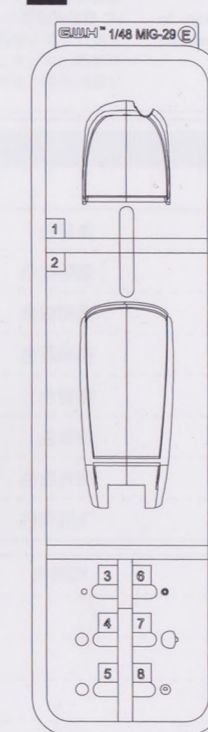

PE Parts x 1

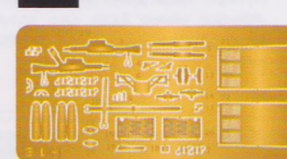

FILM Parts x 1

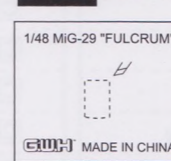

阴影零件不使用
DO NOT USE THE
SHADOW PARTS

DIE-CUT MASK

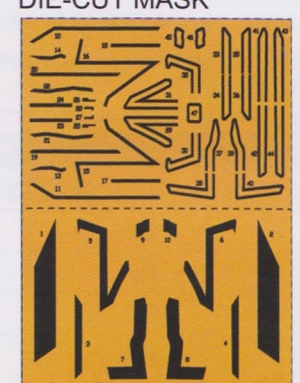

DE A

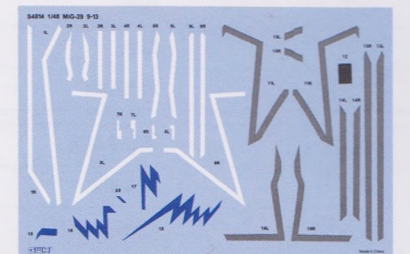

DE B



1

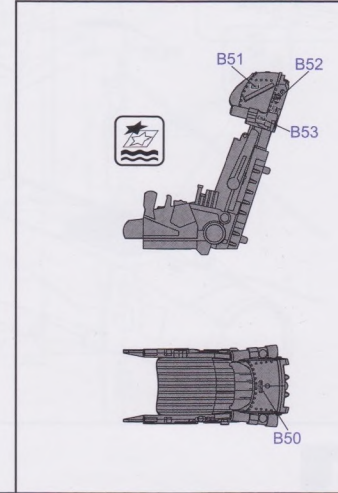
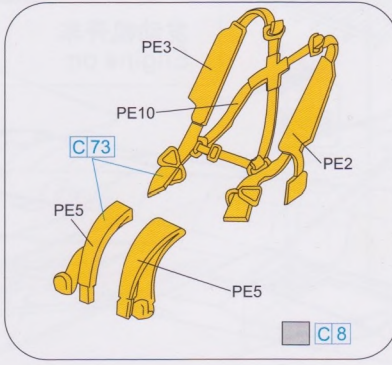
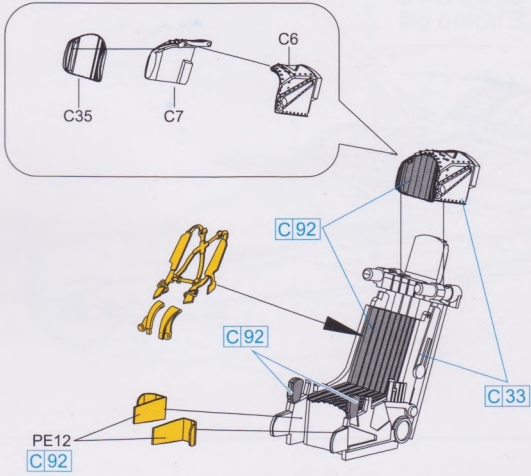
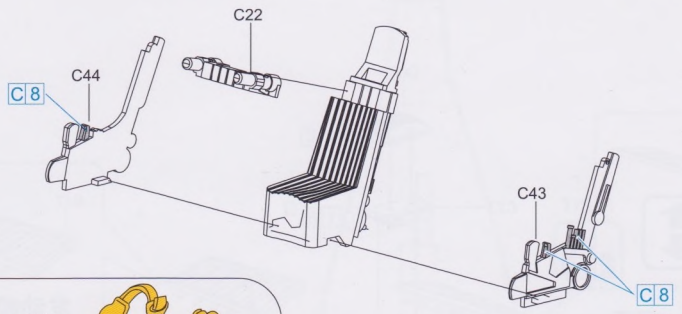
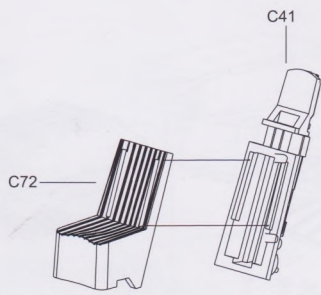

2

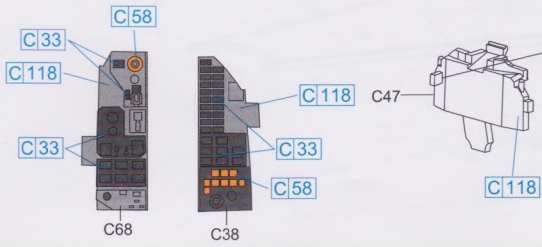
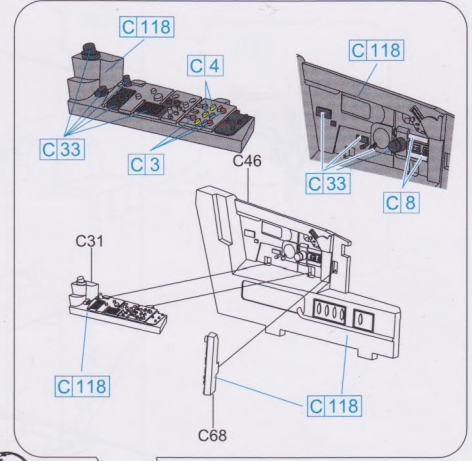
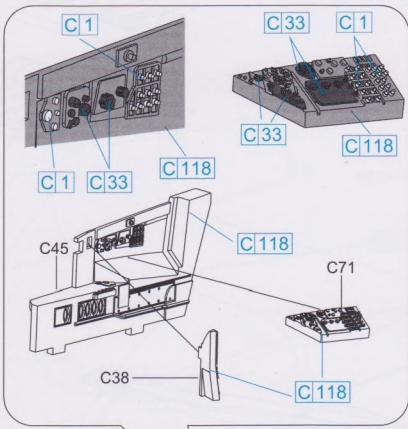
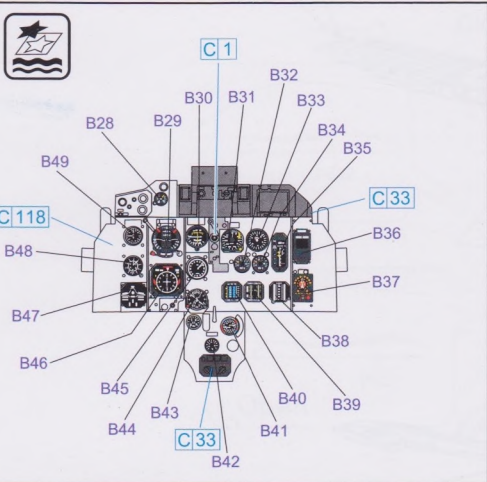
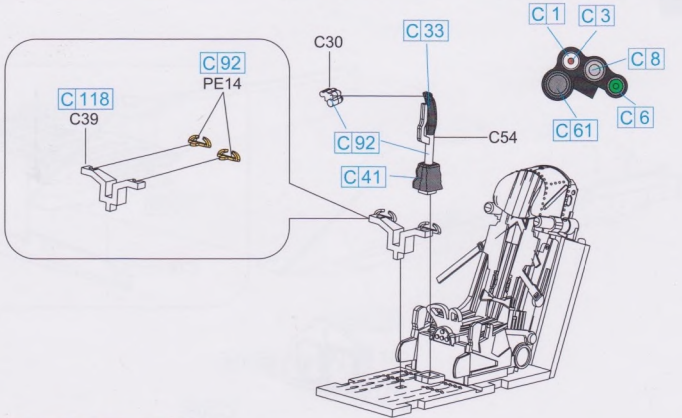
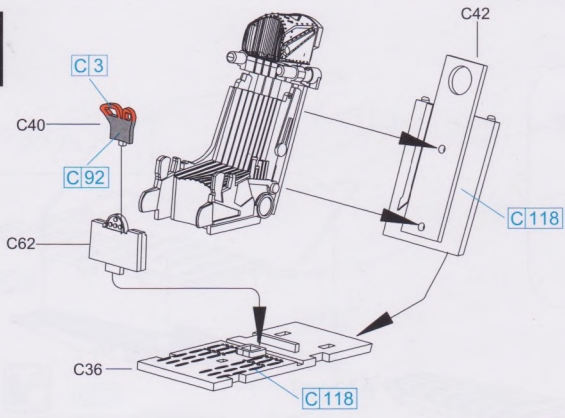

3

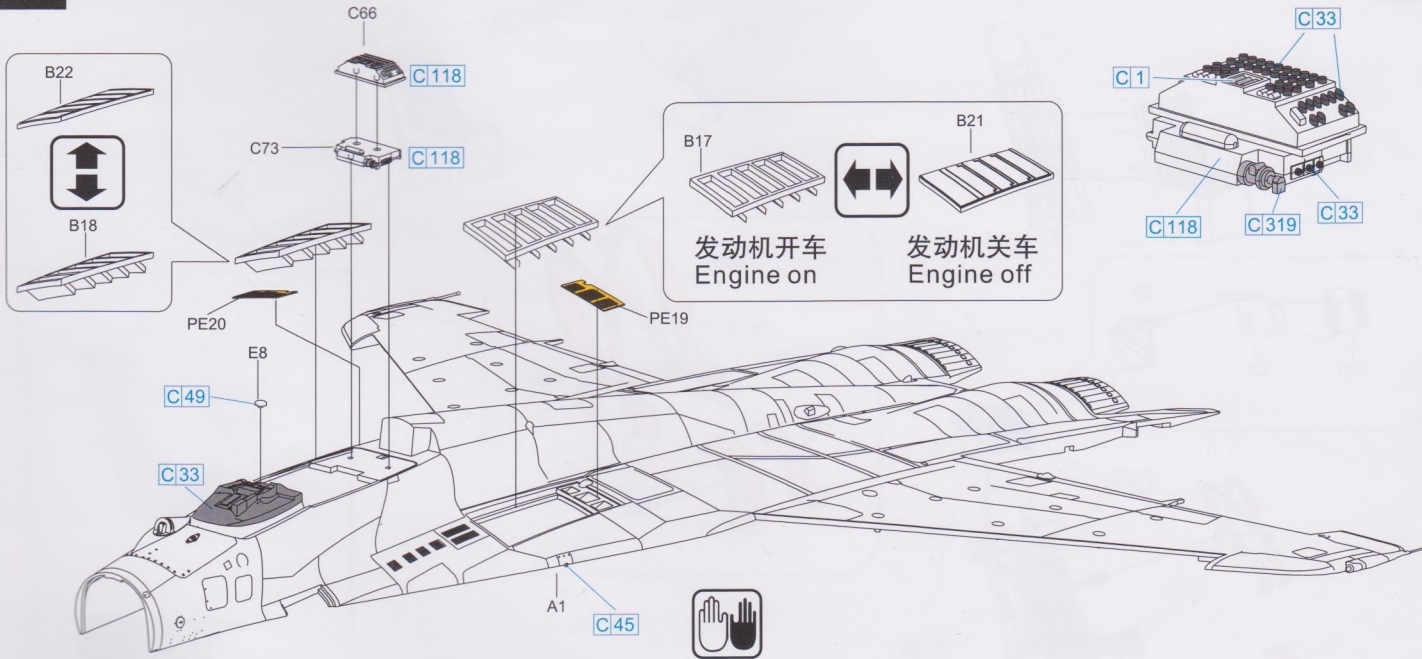

4

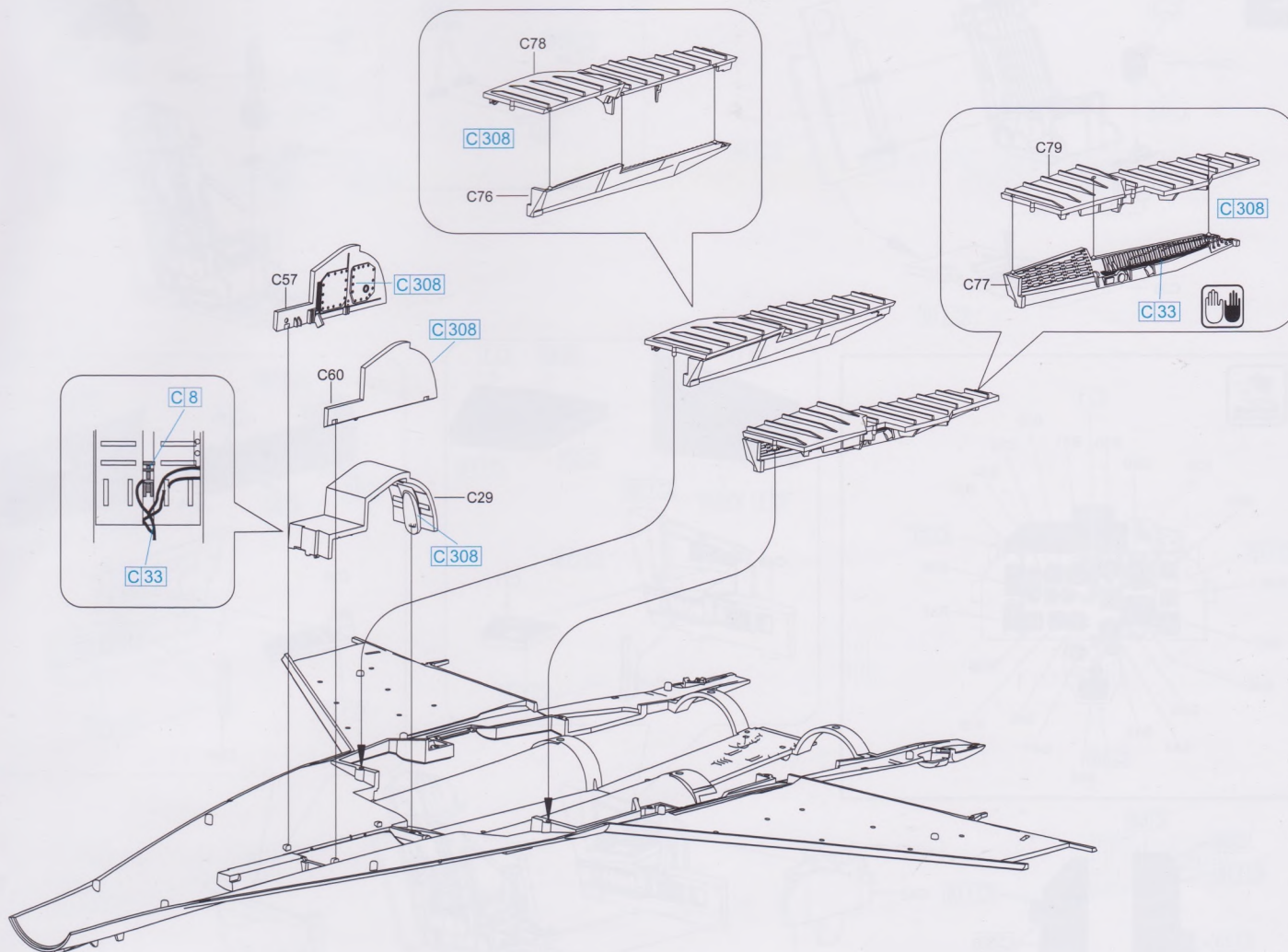

5

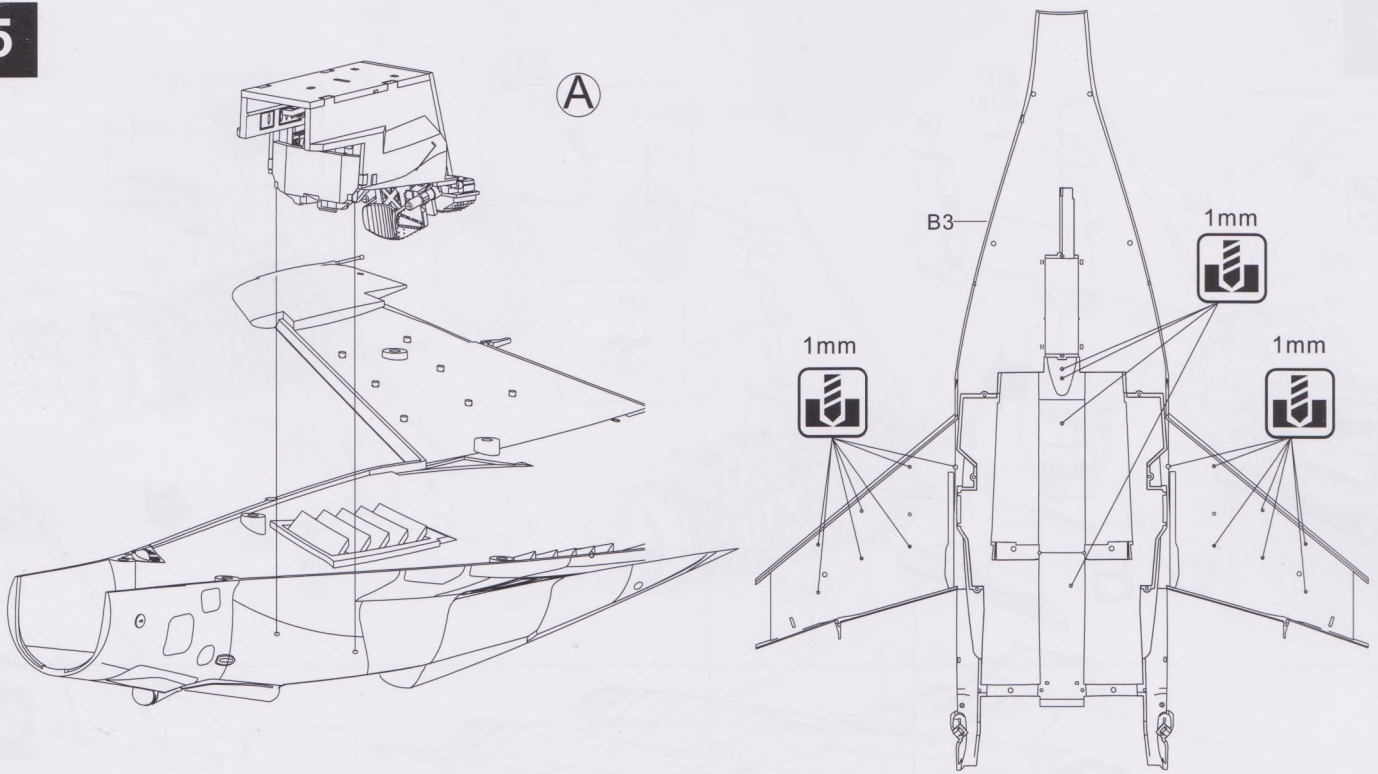

6

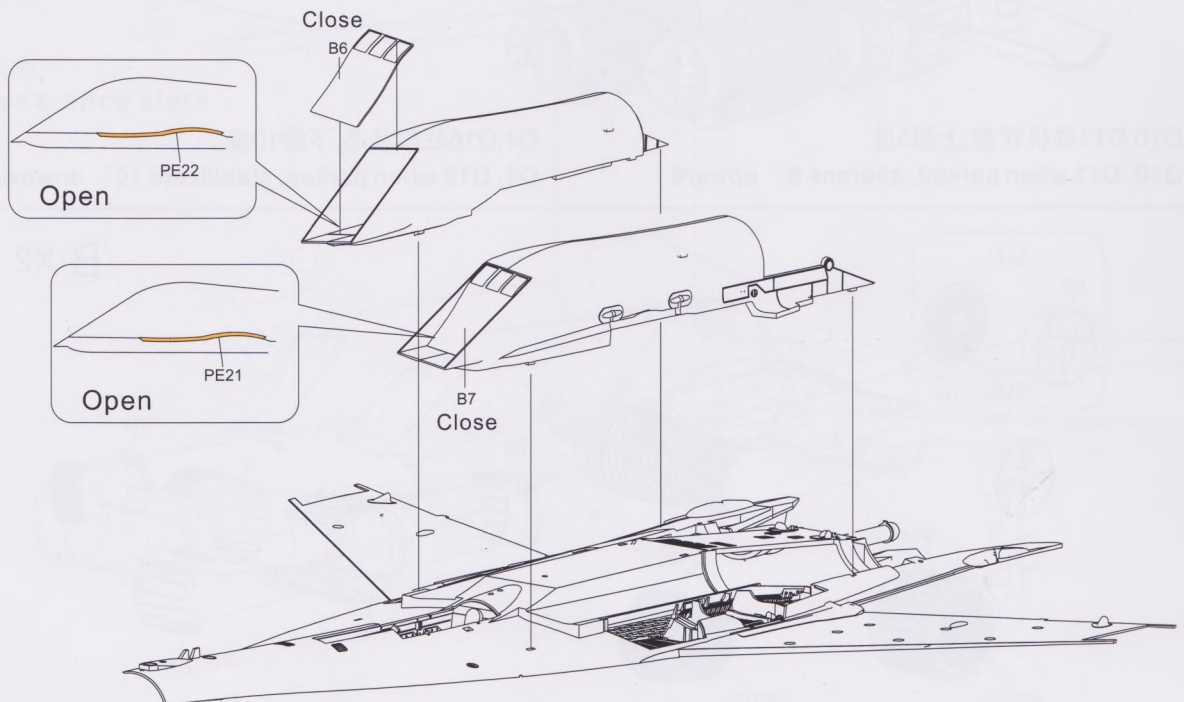
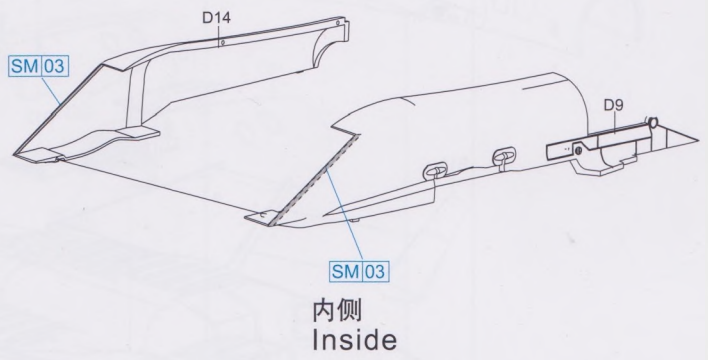
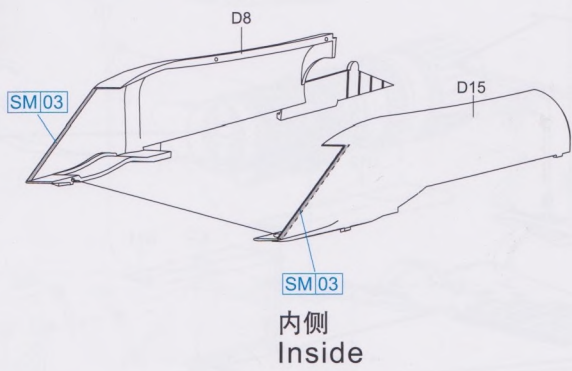

7

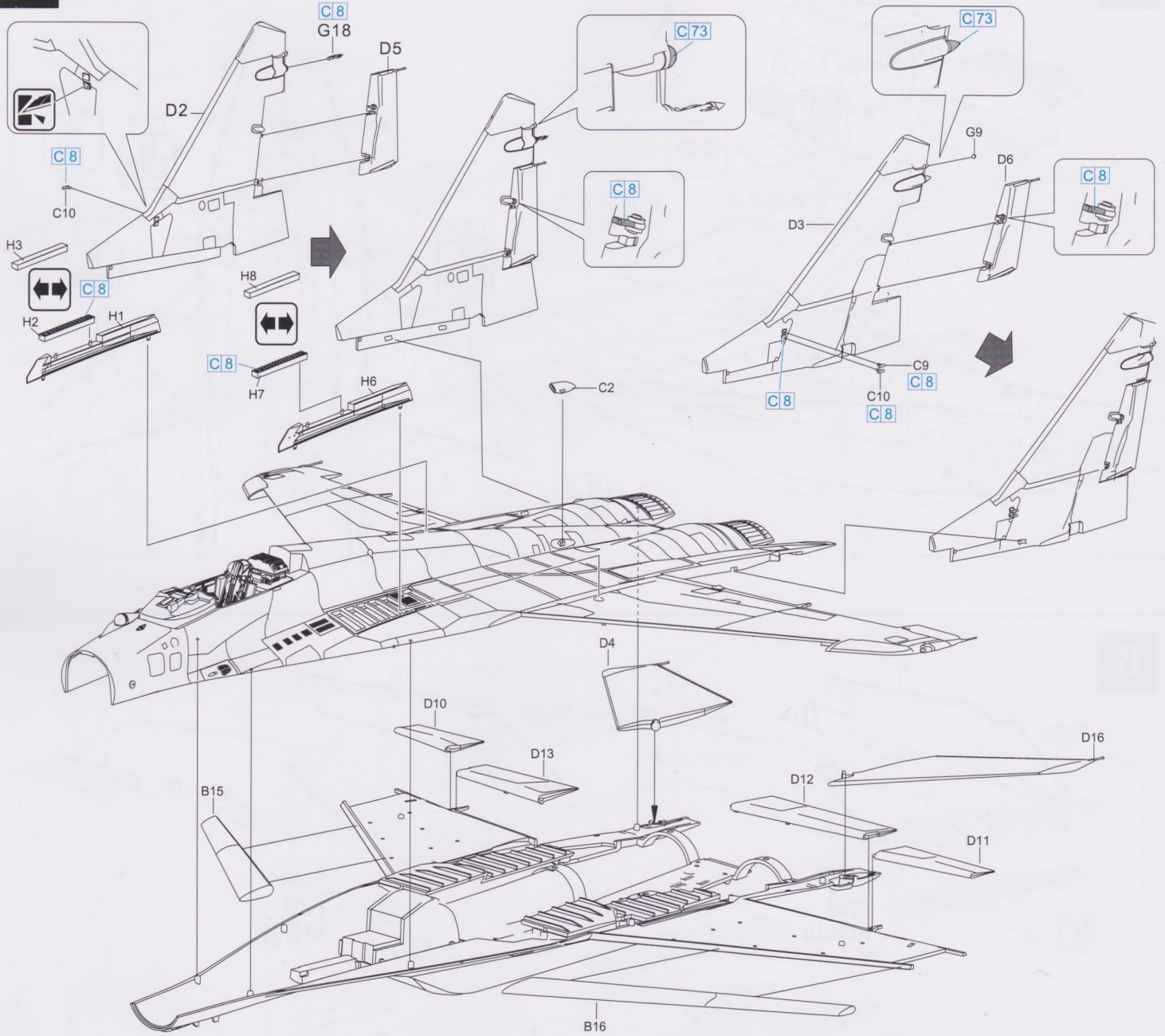

D10, D11 驻机状态, 上翘5度
 D10, D11 when parked, ailerons 5° upward

D4, D16 驻机状态, 下垂10度
 D4, D16 when parked, stabilizers 10° downward

8

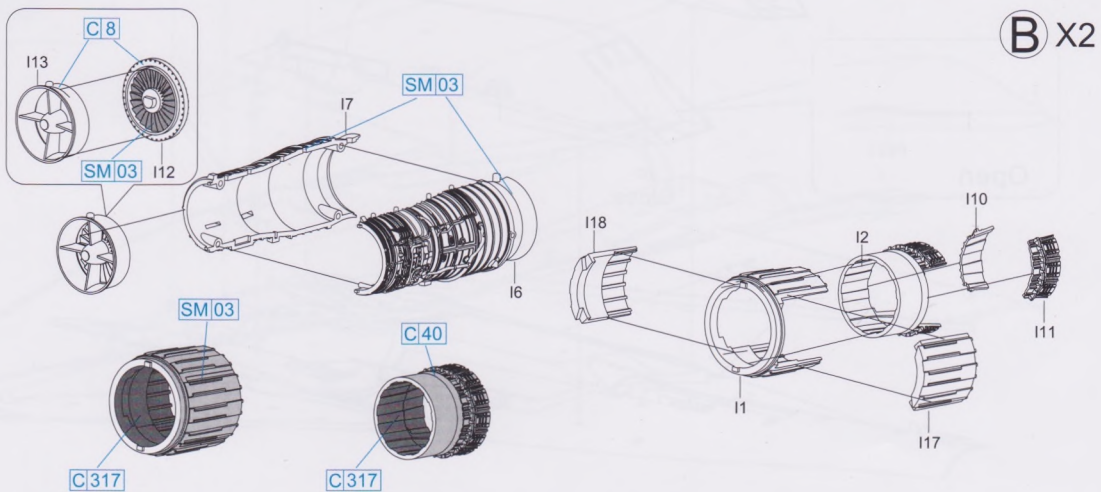

9

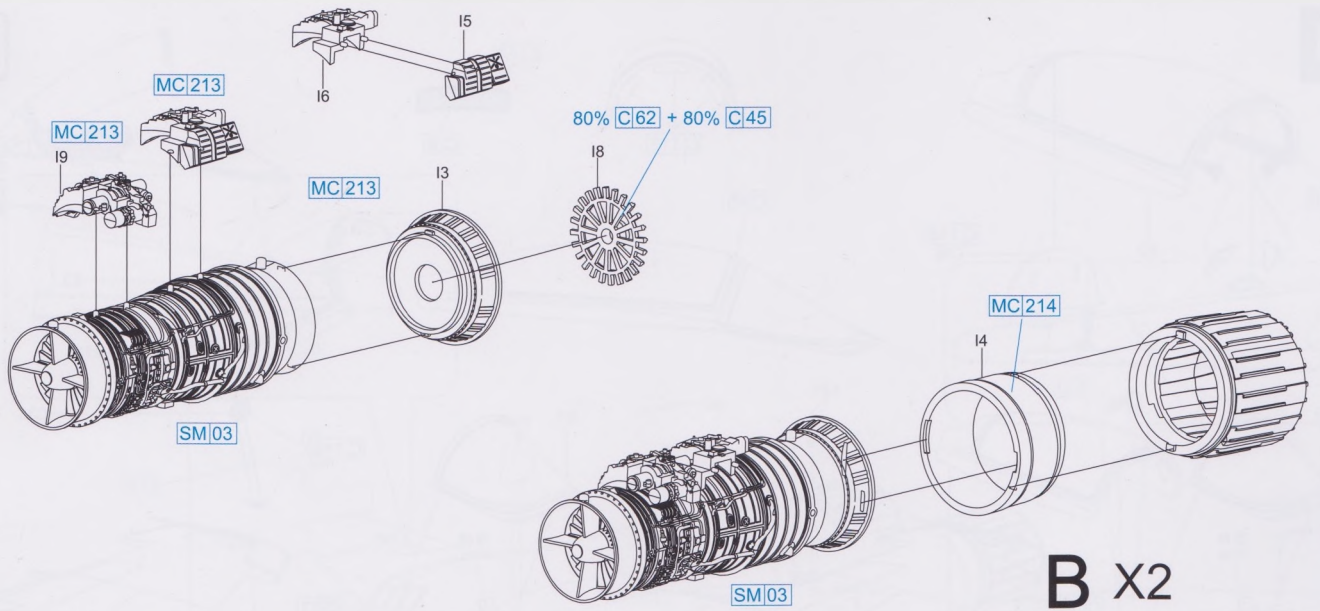

10

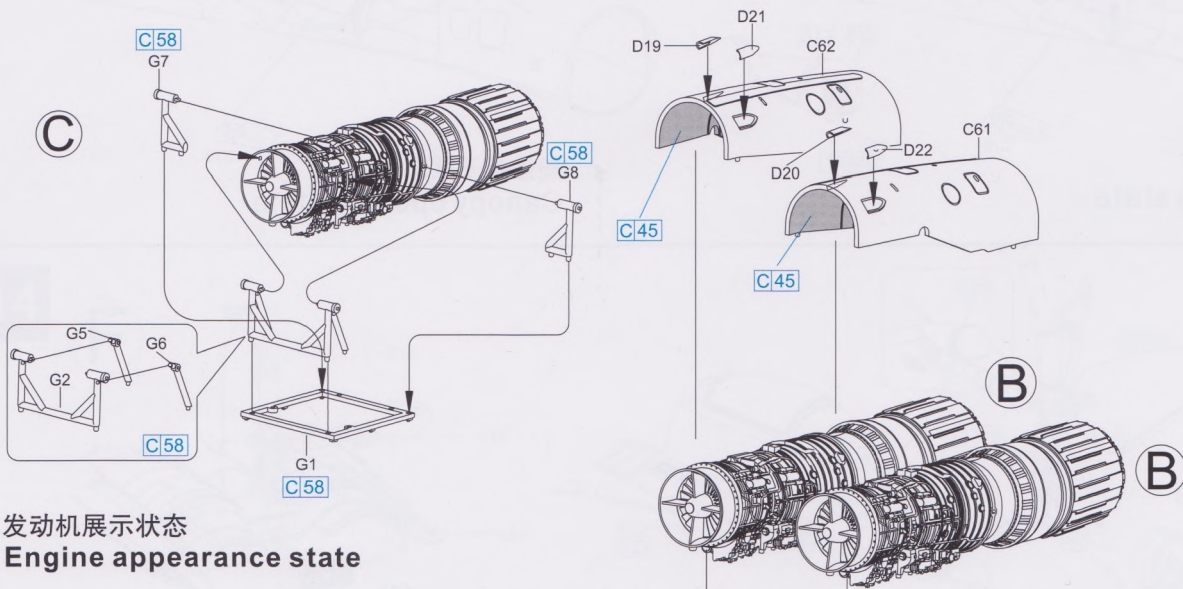

发动机展示状态
Engine appearance state

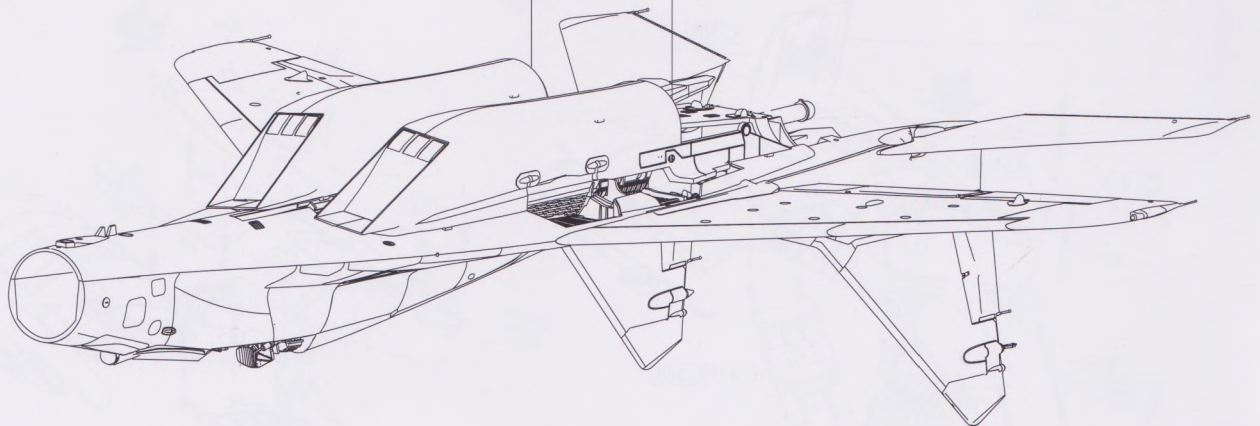

11

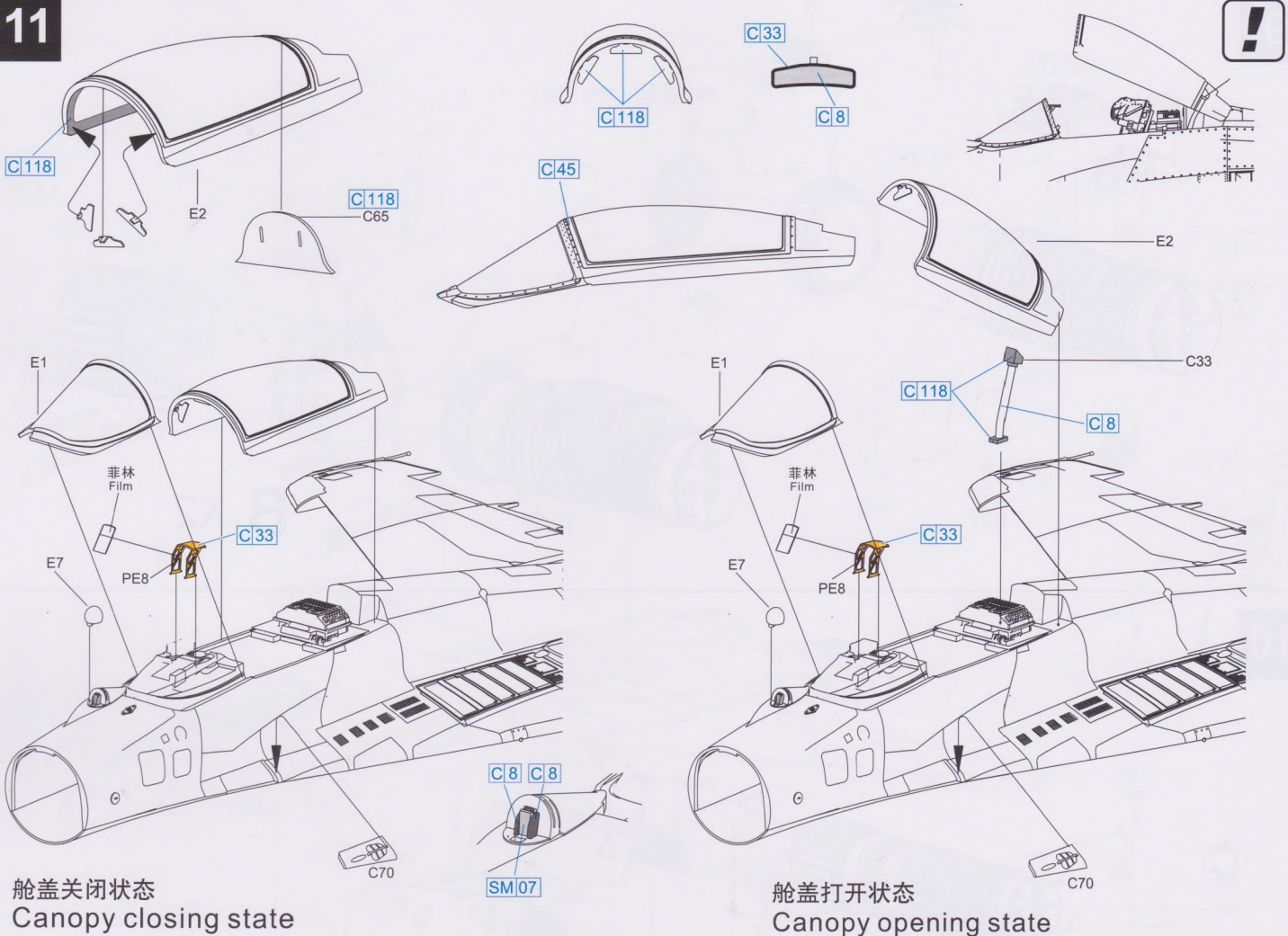

舱盖关闭状态
Canopy closing state

舱盖打开状态
Canopy opening state

12

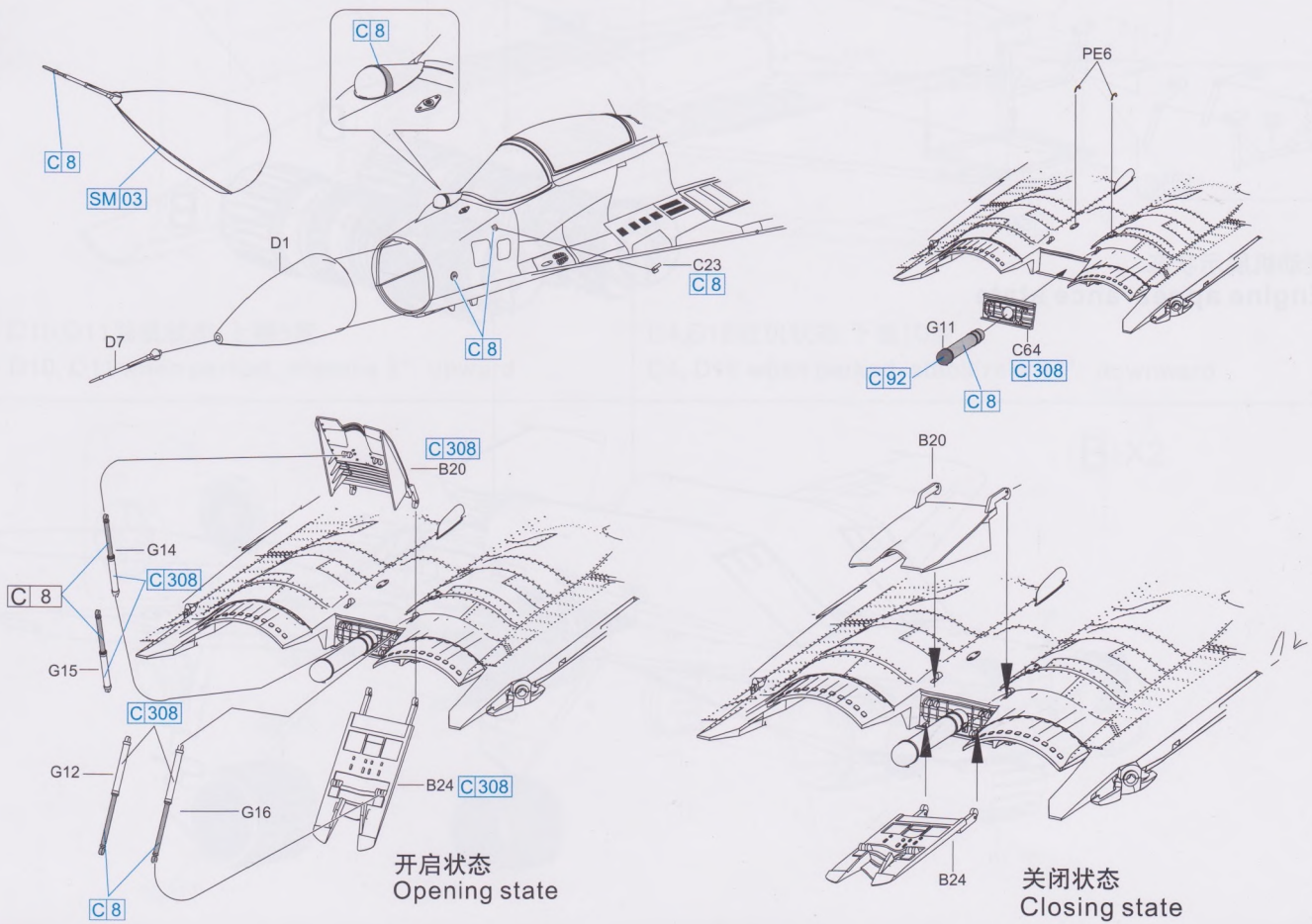

开启状态
Opening state

关闭状态
Closing state

13

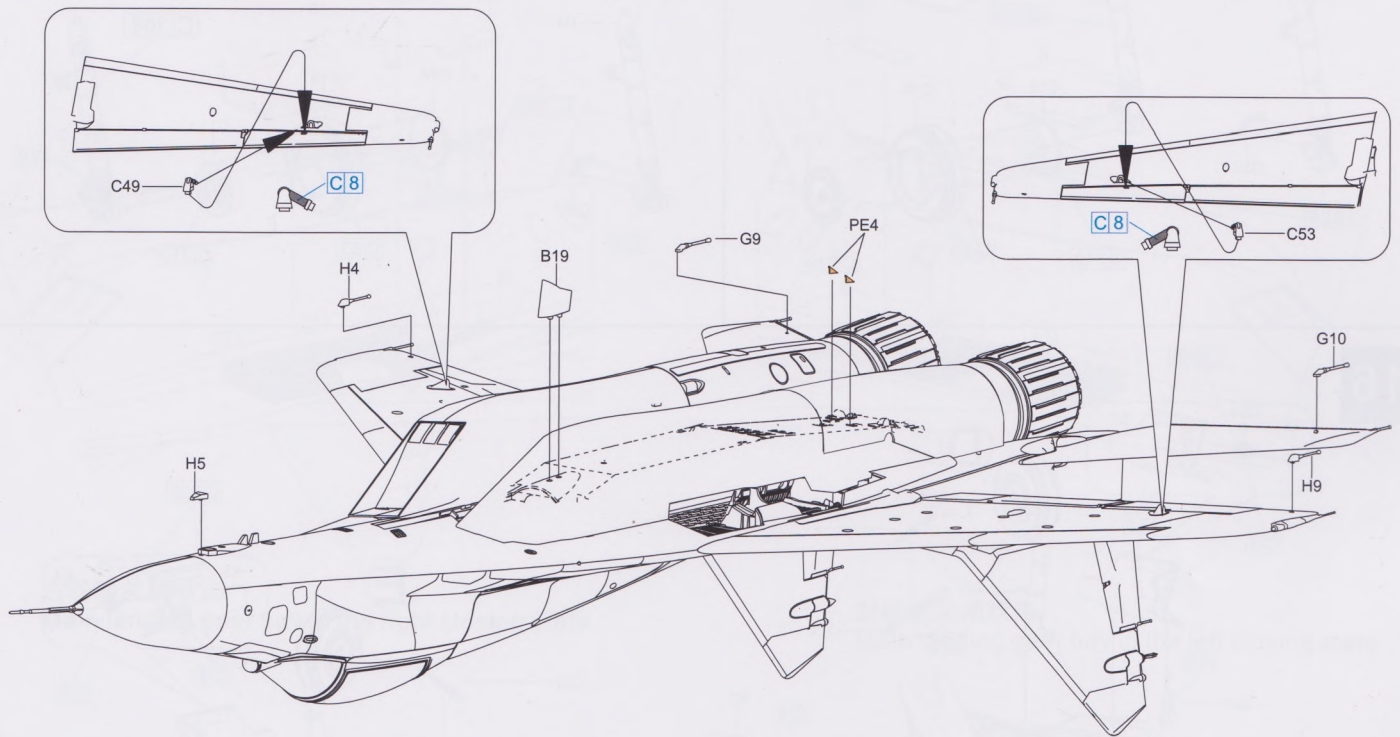

14

F

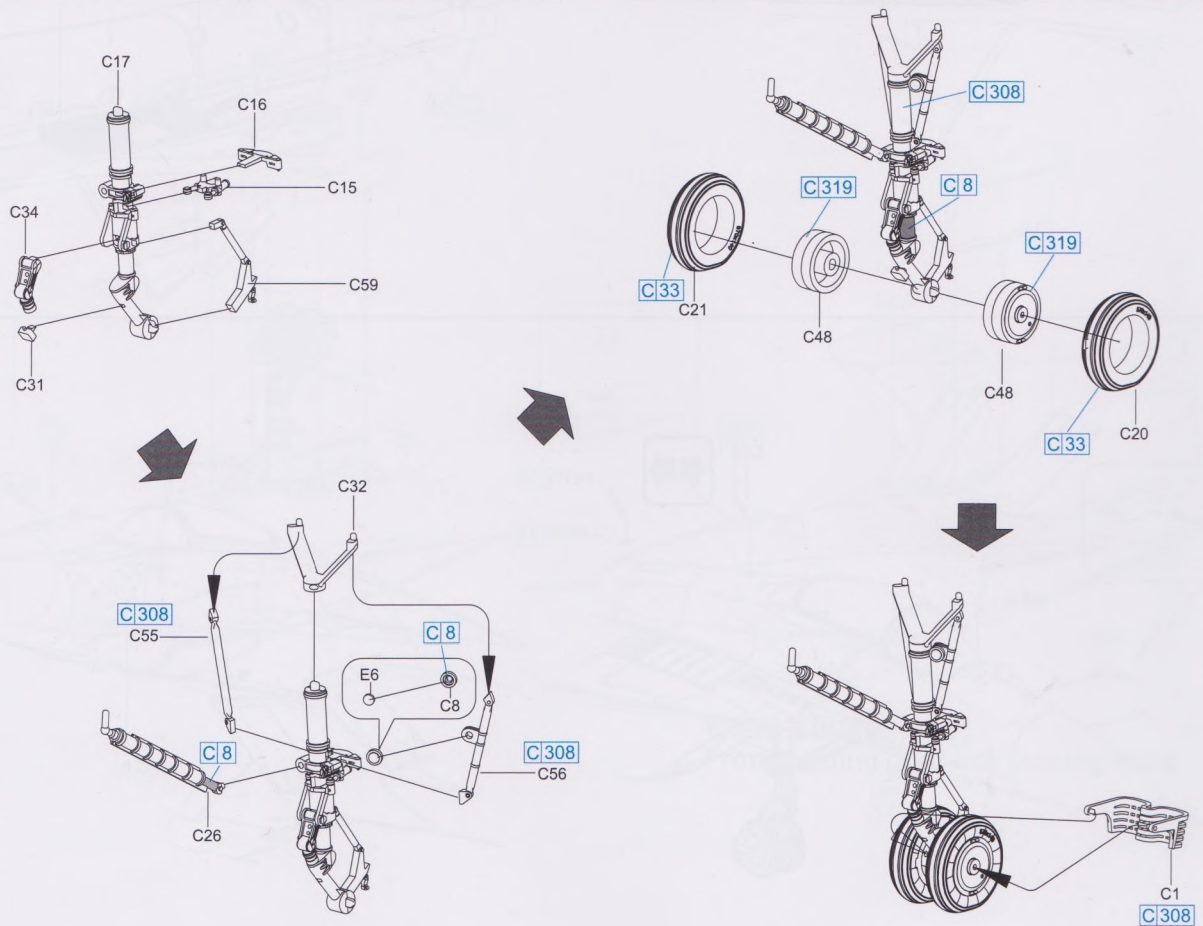

15

D

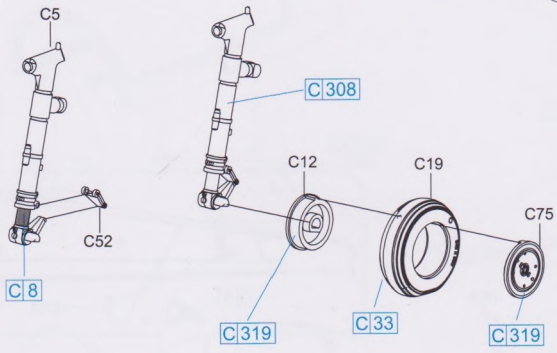

E

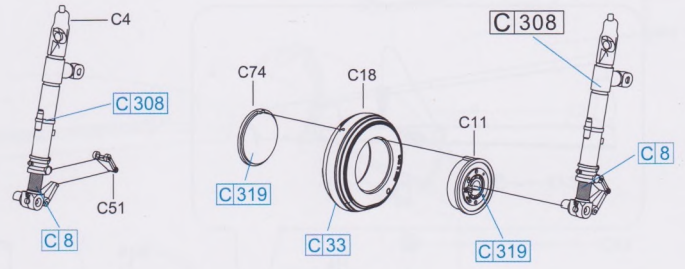

16

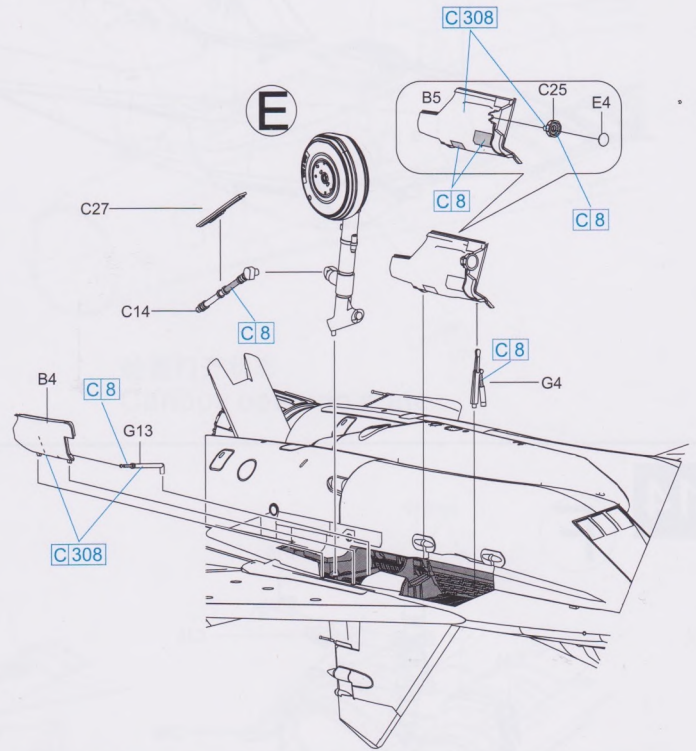
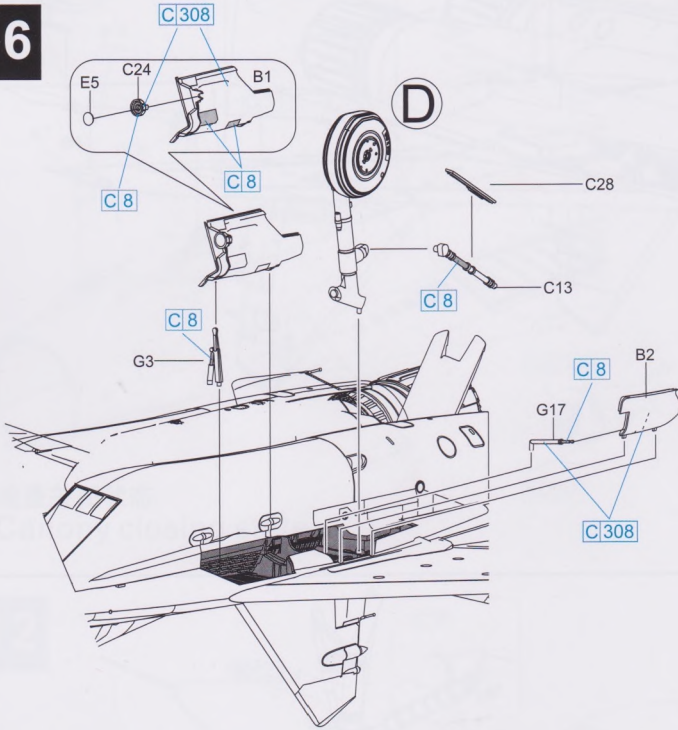

17

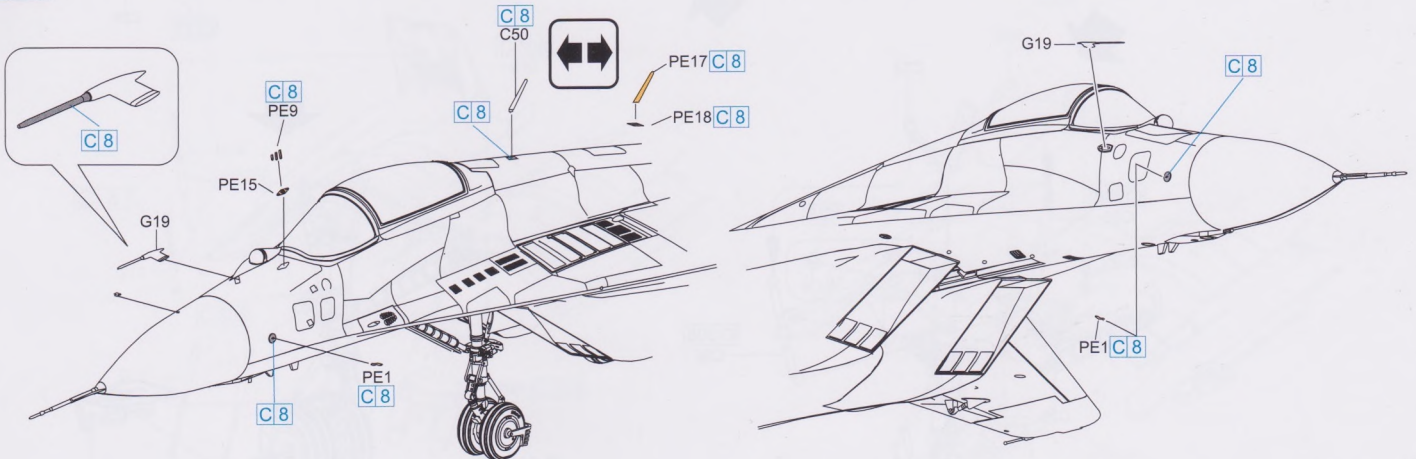

18

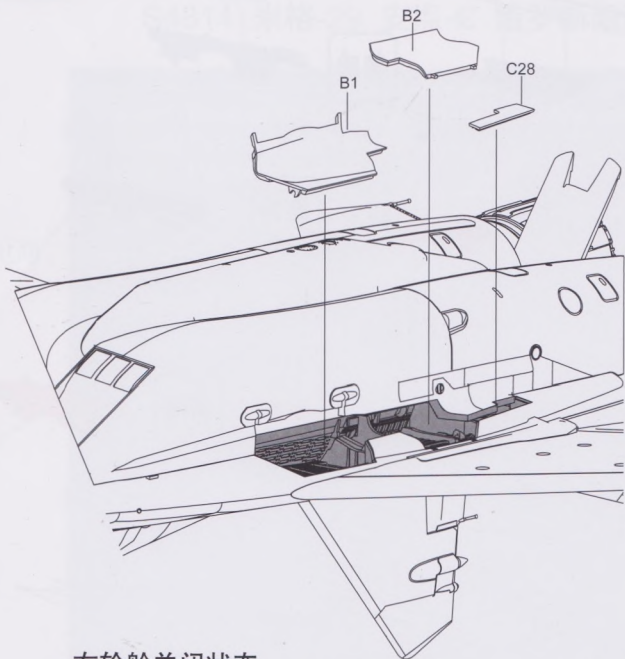

右轮舱关闭状态
Main landing gear bay in the right closing state

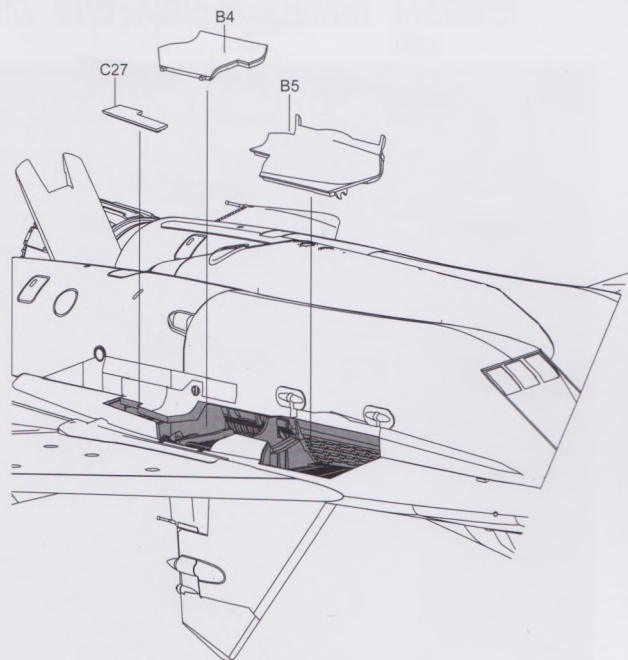

左轮舱关闭状态
Main landing gear bay in the left closing state

19

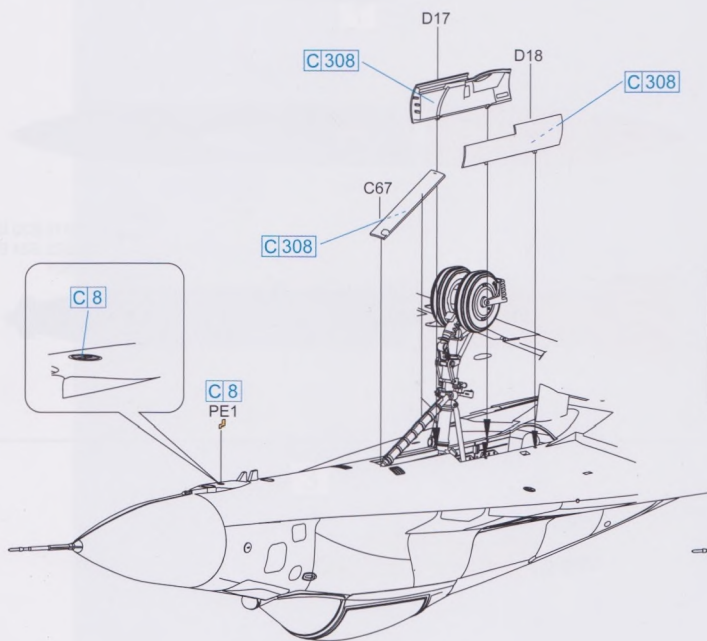

前轮舱关闭状态
Front landing gear bay closing state

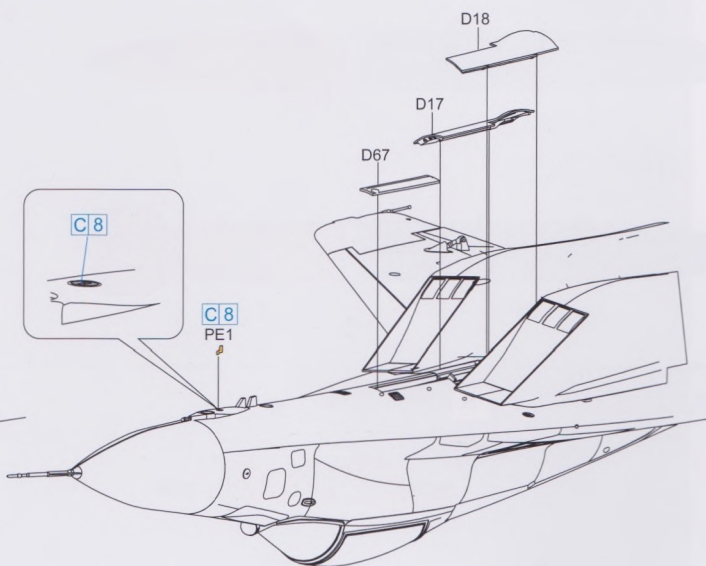

20

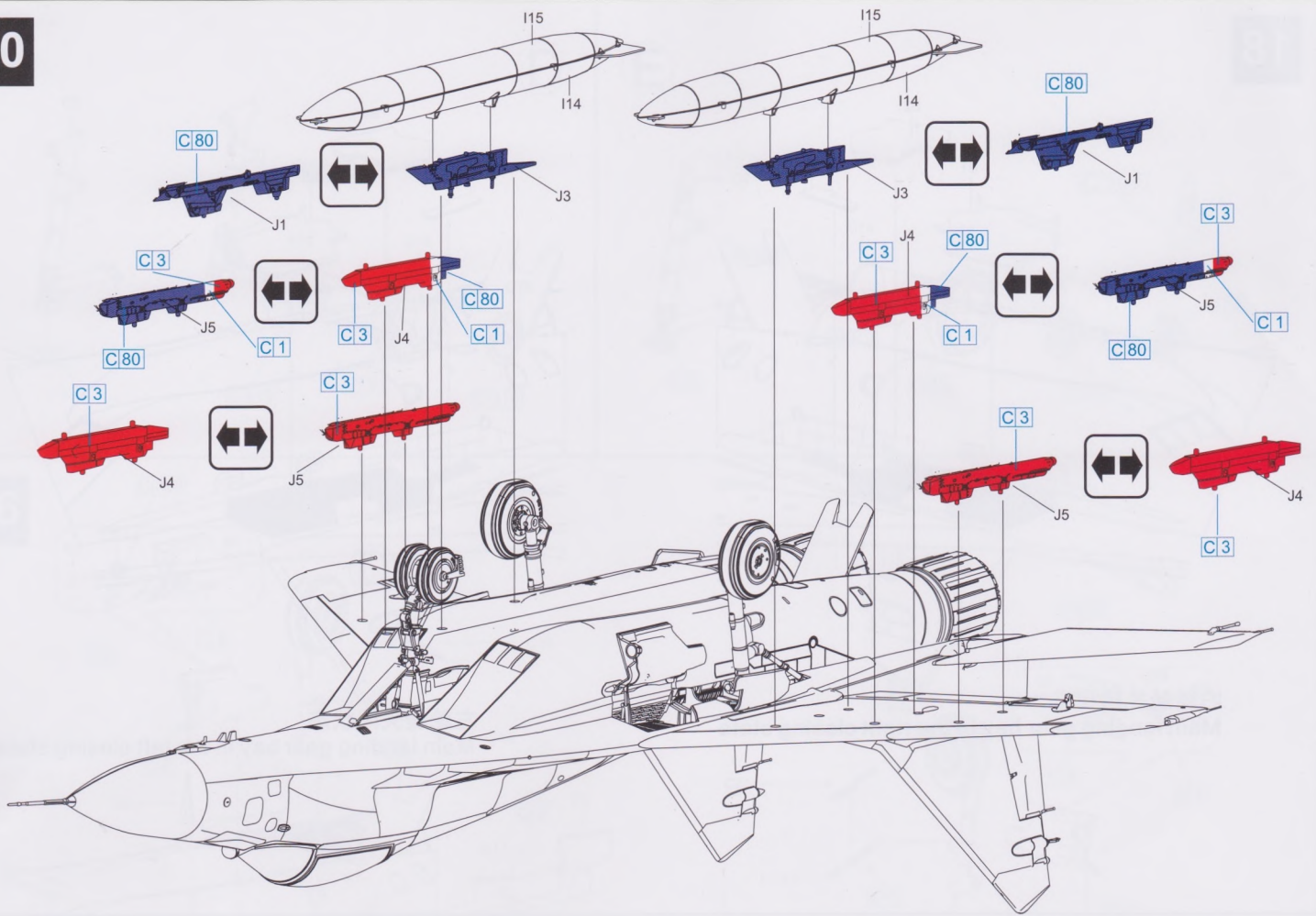

21

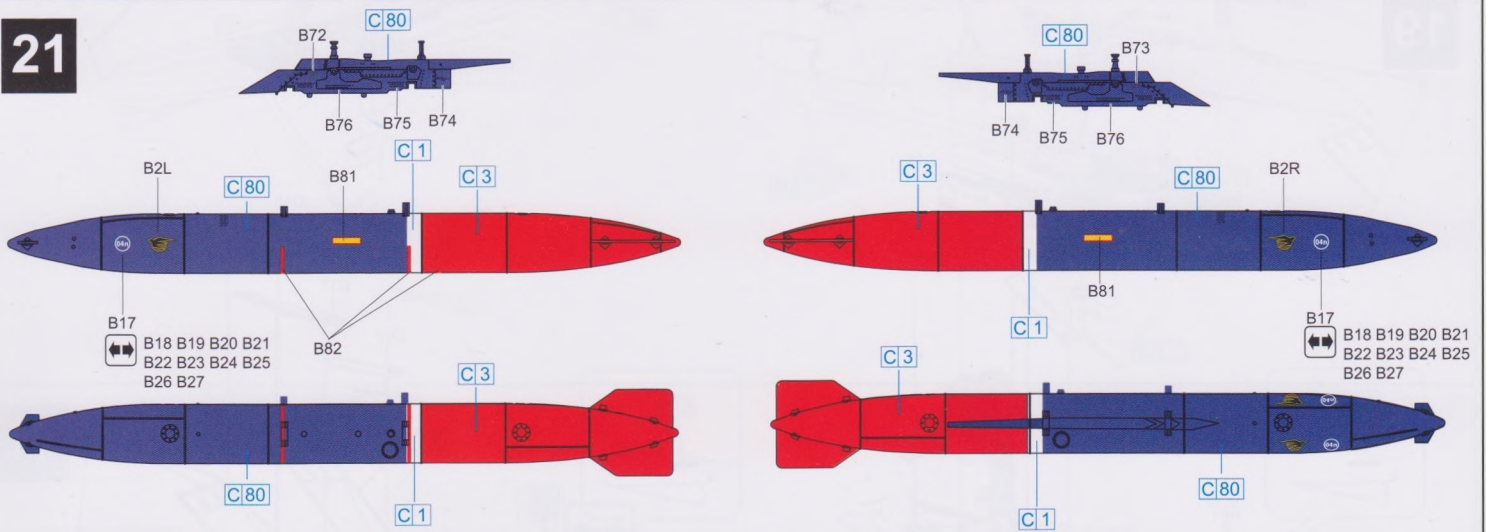

APU-60



APU-470

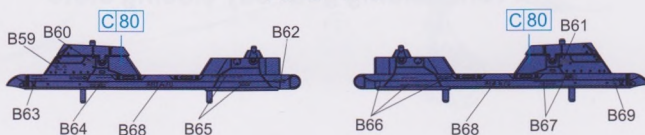

APU-73

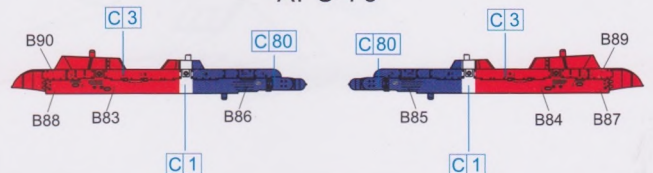

S4814 MiG-29 FULCRUM-C 9-13 SWIFTS DIE-CUT FLEXIBLE MASK

S4814 米格-29 支点-C 俄罗斯雨燕飞行表演队 机身分色喷涂遮盖贴纸 粘贴指示

Step1, Paint all in white, then mask the white area.
Step2, Paint the swift in blue.
Step3, Paint the red area.

步骤1, 全机涂装白色, 遮盖白色区域;
步骤2, 涂装蓝色雨燕图案;
步骤3, 涂装红色区域

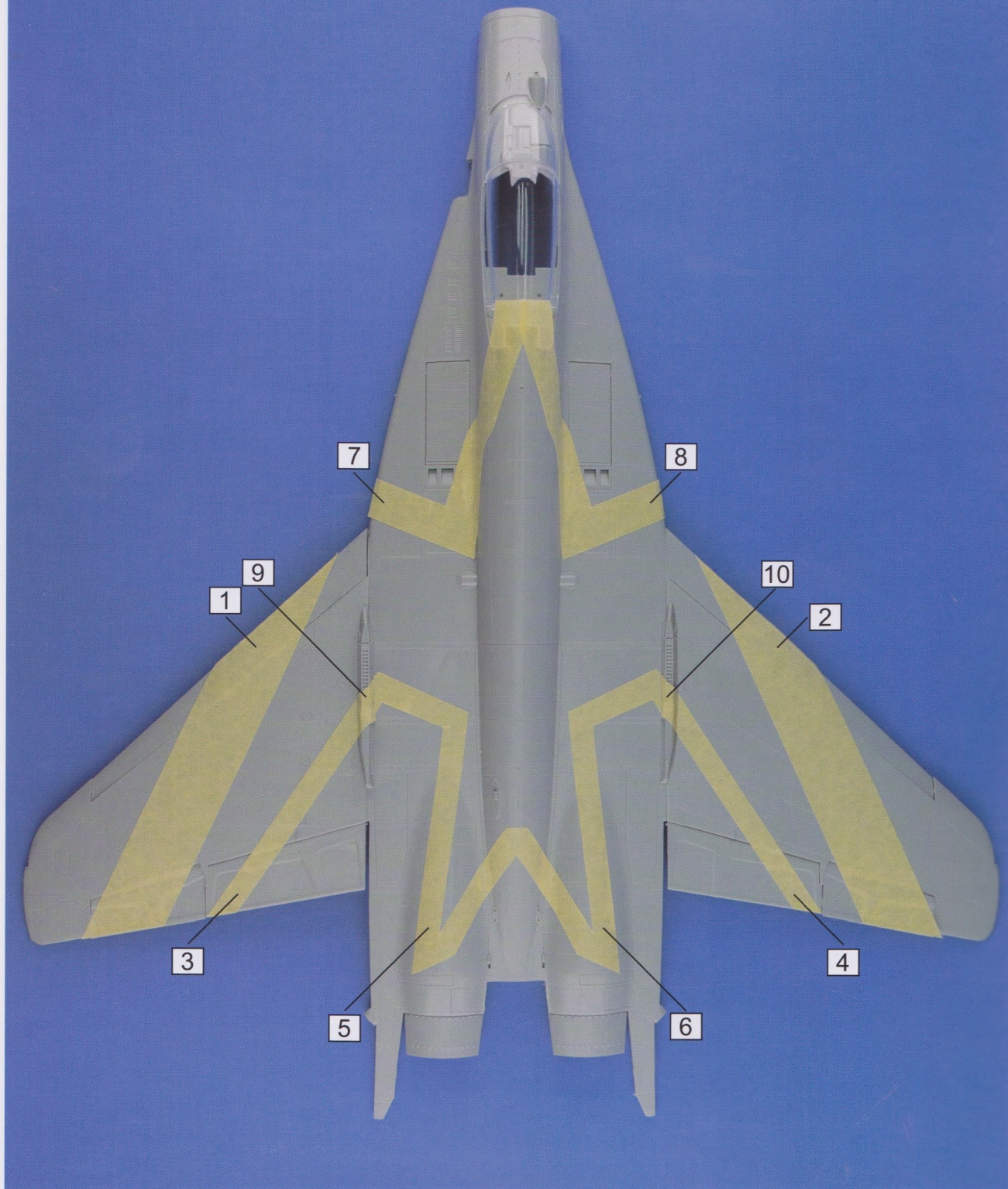

S4814 MiG-29 FULCRUM-C 9-13 SWIFTS DIE-CUT FLEXIBLE MASK

S4814 米格-29 支点-C 俄罗斯雨燕飞行表演队 机身分色喷涂遮盖贴纸 粘贴指示

Step1, Mask the white area, Left the silver stripes.
Step2, Paint silver stripes.

Note: You can use decals instead of painting, You can see how to use in the indication pages.

步骤1, 在白色区域中遮盖镂出银色条纹位置;
步骤2, 涂装银色条纹;

注: 此步骤可以水贴粘贴代替,
粘贴方法见涂装指示。



S4814 MiG-29 FULCRUM-C 9-13 SWIFTS DIE-CUT FLEXIBLE MASK

S4814 米格-29 支点-C 俄罗斯雨燕飞行表演队 机身分色喷涂遮盖贴纸 粘贴指示

Step1, Paint all in white, then mask the white area.
Step2, Paint the swift in blue.
Step3, Paint the red area.

步骤1, 全机涂装白色, 遮盖白色区域;
步骤2, 涂装蓝色雨燕图案;
步骤3, 涂装红色区域

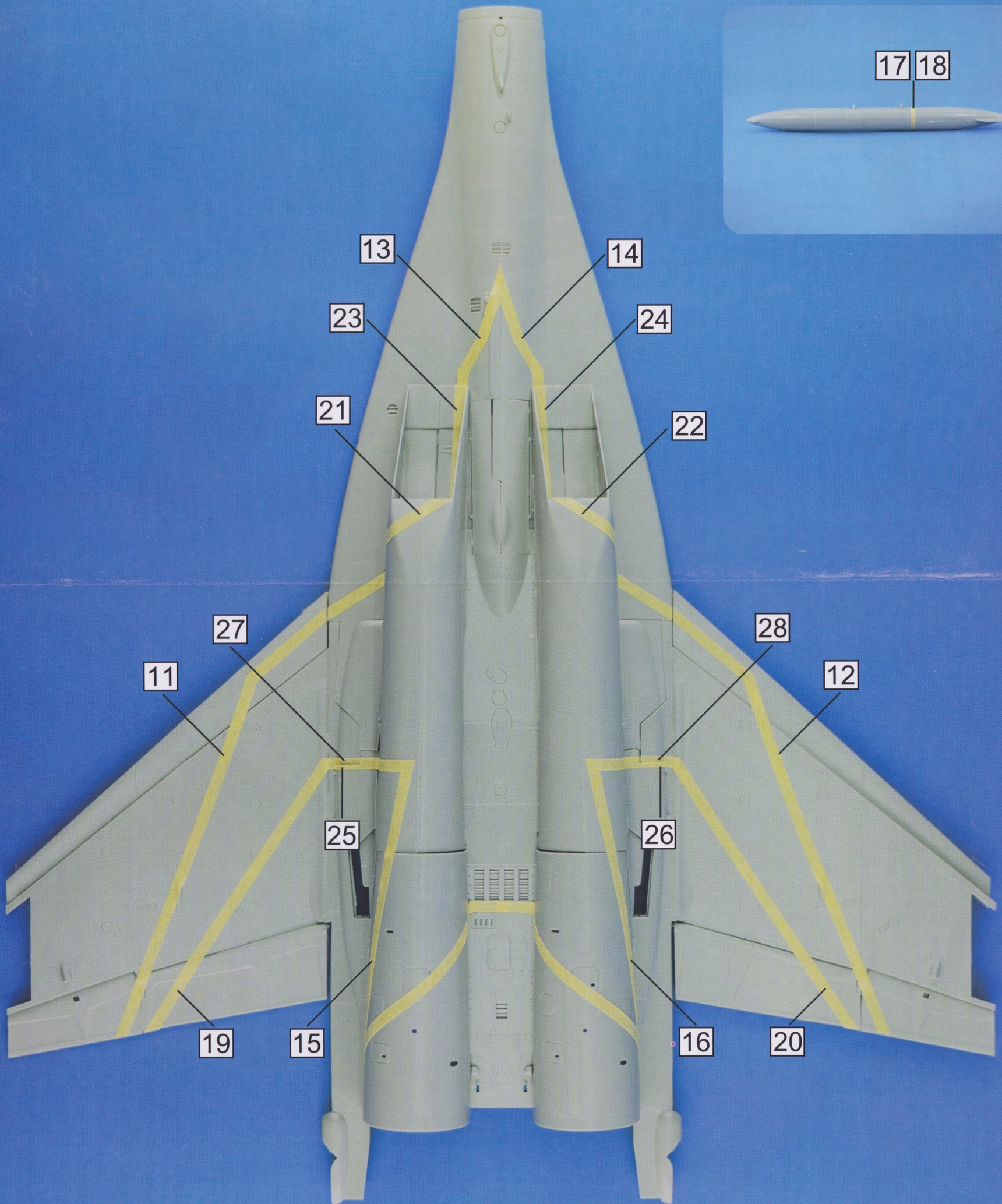
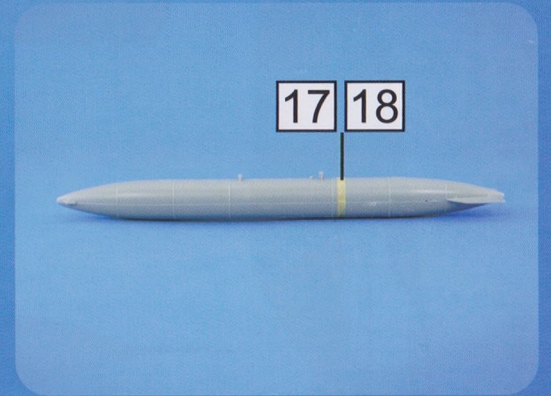

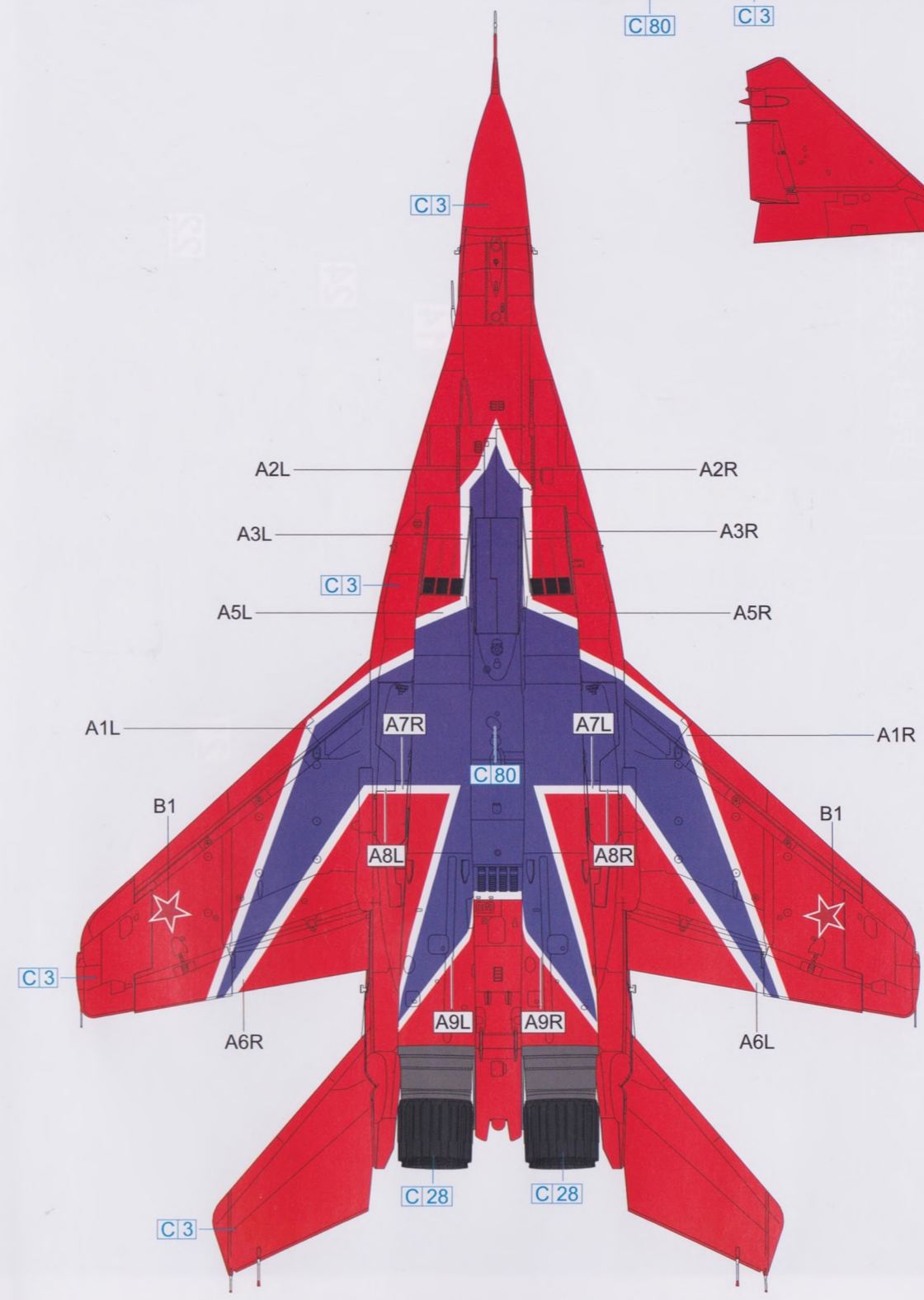
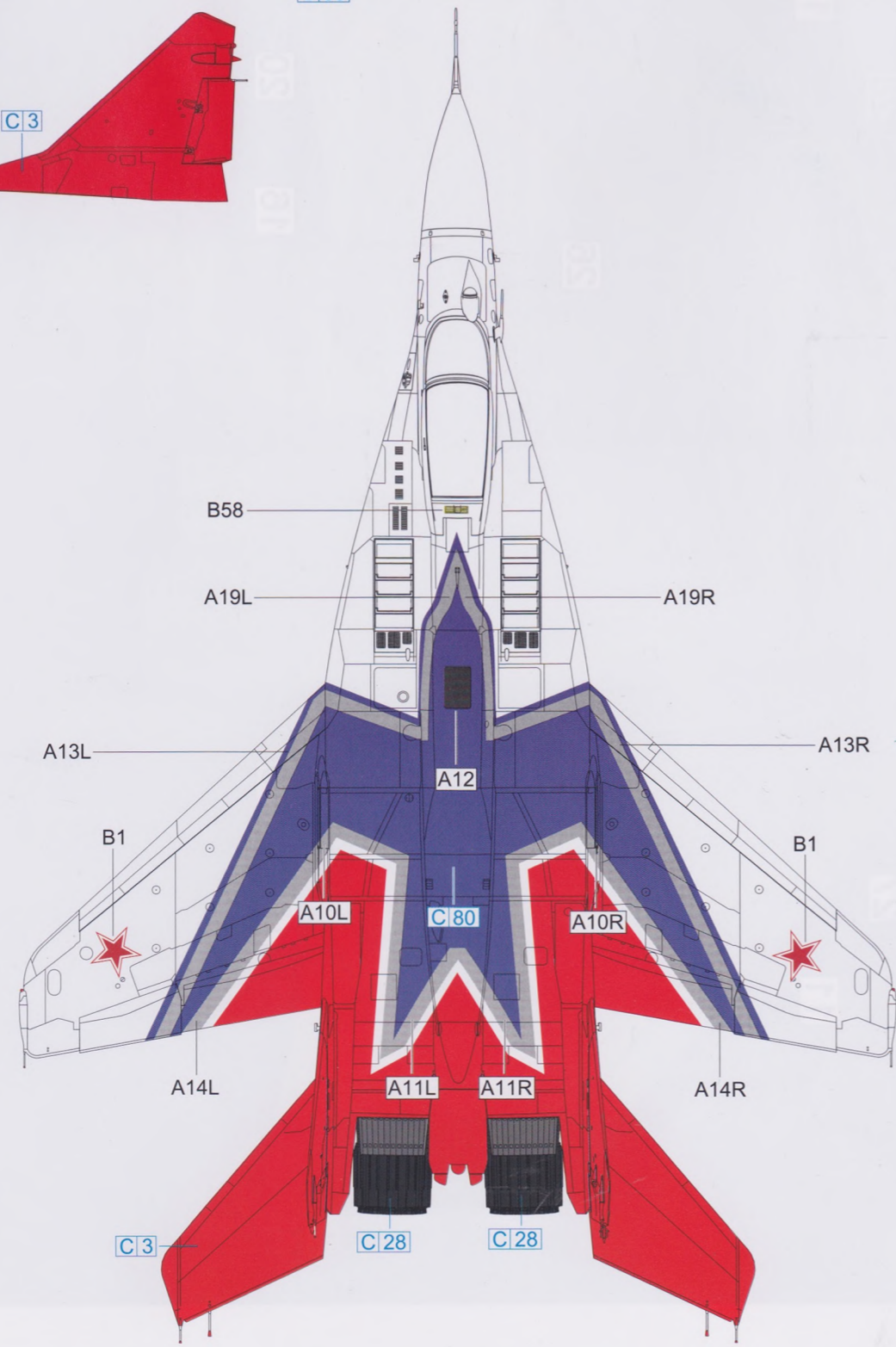
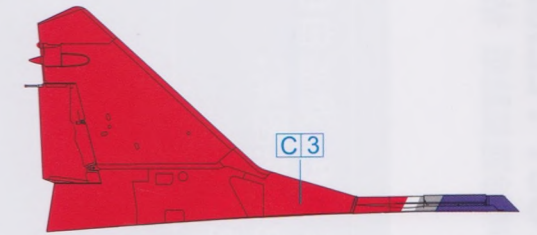
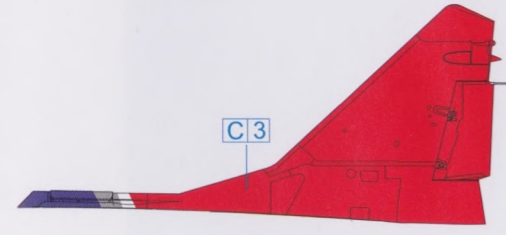
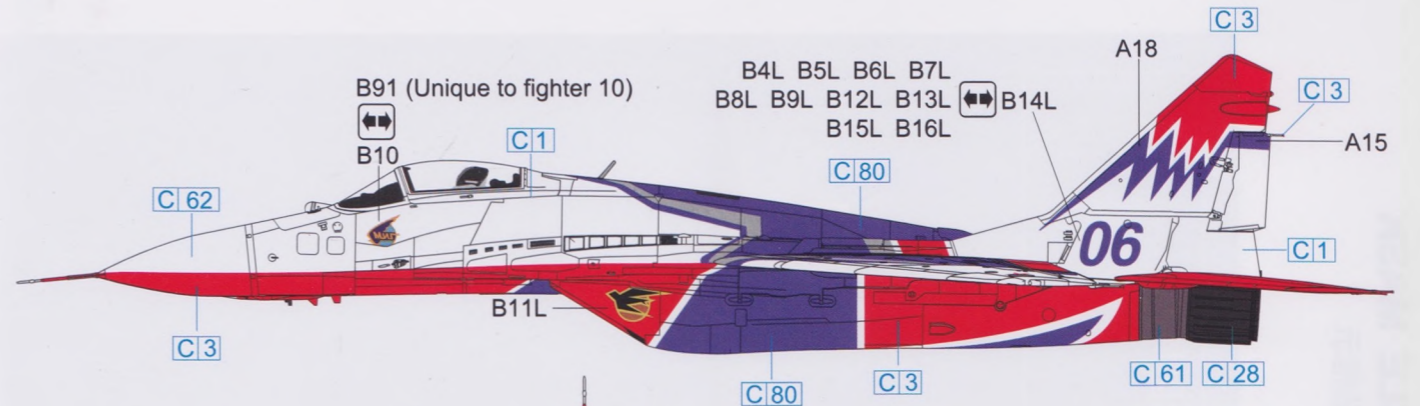
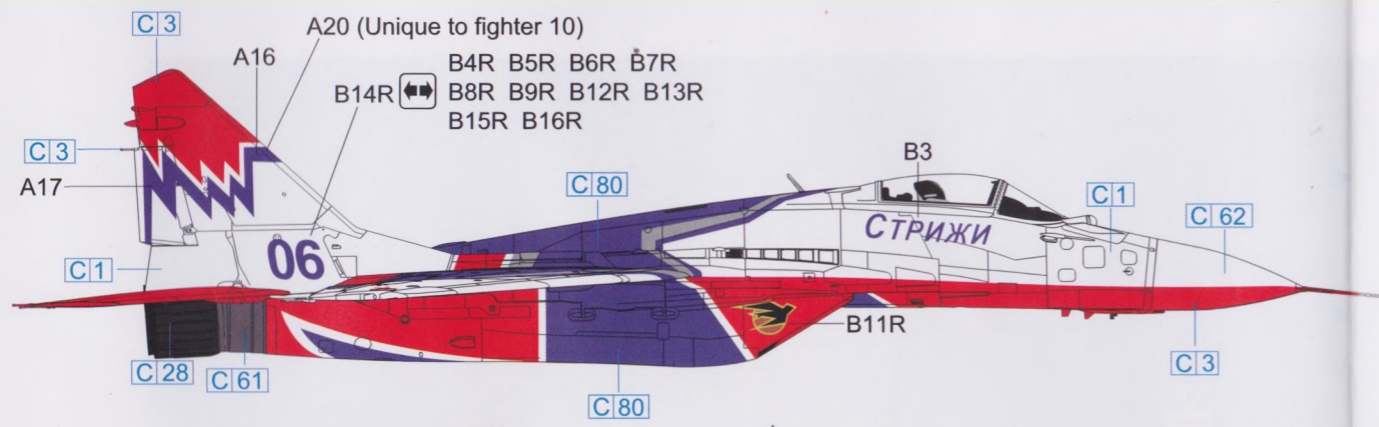

注意事项 CAUTION 組み立てのご注意

- (1) 勿于近火处使用胶水或油漆,并打开窗户保持空气流通。
- (2) 涂料的号码请参考本栏以下的说明。本品本身不包括胶水和涂料。
- (3) 自板件中取出部件时,应用模型专用剪,并用介刀或小锉除去多余胶料。
- (4) 各图形的含义可参考本栏以下说明。

- (1) When you use glue or paint, do not use near a open flame, and use in a well-ventilated room.
- (2) See below for the color list. Glue and paint are not included in the kit.
- (3) When you take parts off the runner frame, use the modeling scissors and trim excess plastic with a cutter or a file.
- (4) See below for the meaning of symbols.

- (1) 接着剂や塗料は火の近くで使わないで下さい、使用の際は換気をよくして下さい。
- (2) 塗料指定のは下記のとおりです、接着剤や塗料は入っていませんので別に求めて下さい。
- (3) 部品のランナーから切り離す時は模型用ハサミ等を使い、余分な部分はカッターやヤスリ等で仕上げして下さい。
- (4) 組立図のサインマークは下の説明を御覧下さい。

图形含义 CAUTION マーク



填平
FILL HOLE
穴を埋めて下さい



水印粘纸
APPLY DECAL
デカールを貼って下さい



切除
CUT OFF
切り取って下さい



弯折
BEND
折り曲げて下さい



制作两组
MAKE TWO SET
2個作って下さい



另一側相同制作
DO THE SAME ON THE OPPOSITE
反対側も取り付けます



胶水
CEMENT
接着して下さい



钻孔
OPEN HOLE
穴を開けて下さい



选择使用
OPTIONAL
どちらを選んで下さい



不用胶水
NO CEMENT
接着しないで下さい



注意
BE CAREFUL
注意して下さい



瞬间胶
INSTANT GLUE FOR METAL
瞬間接着剂(金属用)

所使用工具 RECOMMENDED TOOLS 専用工具

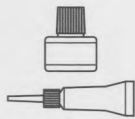

塑胶件用模型胶水
Cement
プラスチック用接着剂

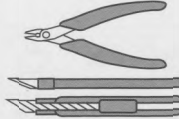

模型用剪钳
Side cutters
模型用ニッパー

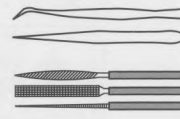

模型用镊子
Tweezers
ピンセット

模型用瞬间胶水
Instant Cement
瞬間接着剂

模型用刻刀
Modeling knife
模型用ナイフ

模型用锉刀
Diamond file
模型用ヤスリ

水贴纸使用说明 DECAL APPLICATION スライドマークの貼り方

- (1) 用模型剪刀或刻刀切下所需的图案部分。
- (2) 将水贴纸浸泡在温水中10秒左右取出放置于戏水的干布上。
- (3) 手拿着水贴纸基的一角,用模型镊子小心夹住浮起的水贴图案移至模型表面准确位置。
- (4) 用手指适当沾水均匀涂于水贴图案表面,使其延展移动至精确位置。
- (5) 用柔软吸水的干布将水贴图案中的气泡向一边挤出,使水贴在模型表面保持平整。

- (1) Cut off decal from sheet.
- (2) Dip the decal in tepid water for about 10 sec. and place on a clean cloth.
- (3) Hold the backing sheet edge and slide decal onto the model.
- (4) Move decal into position by wetting decal with finger.
- (5) Press decal down gently with a soft cloth until excess water and air bubbles are gone.

- (1) 貼りたいマークをハサミで切り抜きます。
- (2) マークをぬるま湯に10秒ほど浸してからタオル等の布の上に置きます。
- (3) 台紙のはしを手で持ち、貼るところにマークをスライドさせてモデルに移して下さい。
- (4) 指に少し水を付けてマークを濡らしてながら、正しい位置にずらしません。
- (5) 柔らかな布でマークの内側の気泡を押し出しながら、押しつけるようにして水分をとります。

蚀刻片使用说明 PHOTO-ETCHED PARTS エッチングパーツ

- (1) 使用蚀刻片专用剪刀或模型专用刻刀将蚀刻片零件切割下待用。
 - (2) 切割下的零件上有蚀刻片的残留连接点部分,使用模型专用锉刀细心打磨干净。
 - (3) 蚀刻片部分在涂装之前必须使用专用的模型金属底漆打底。
- 注意事项: 蚀刻片很薄外延较为尖锐,有刮伤手的可能,在使用之时请务必小心。

- (1) Cut off photo-etched parts using a modeling knife.
 - (2) Carefully remove any excess using a file.
 - (3) Apply metal primer prior to painting.
- Attention, please: Extra care should be taken to avoid personal injury when handling photo-etched parts.

- (1) 切り離す時はカッターナイフを使用してパーツを切り離します。
 - (2) 切り出した時、部品に出張った部品が残っている場合は、ヤスリなどで丁寧に削り落とします。
 - (3) 塗装が必要なパーツは下地にメタルプライマーを吹き付けてから塗装します。
- ご注意: エッチングパーツは大変薄く、手などを切り恐れがあります。取扱いには十分注意して下さい。

涂装色表 PAINT REQUIRED カラー番号リスト

■ [C 000] GSI CREOS Mr.COLOR ■ [00-000] ACRYLICOS VALLEJO ■ FS00000 联邦色号

[C 1]	白色	Gloss White	[C 45]	象牙色	Ivory
[C 2]	黑色	Gloss Black	[C 47]	透明红色	Clear Red
[C 3]	红色	Gloss Red	[C 49]	透明橙色	Clear Orange
[C 4]	黄色	Gloss Yellow	[C 50]	透明蓝色	Clear Blue
[C 6]	绿色	Gloss Green	[C 58]	黄橙色	Yellow Orange
[C 7]	棕色	Brown	[C 61]	烧铁色	Metallic Burnt Iron
[C 8]	银色	Silver	[C 62]	消光白色	Flat White
[C 33]	消光黑色	Flat Black	[C 73]	飞机灰色	Aircraft Grey
[C 92]	半光泽黑色	Semi-gloss Black	[MC 214]	暗铁色	Dark Iron
[C 118]	浅蓝灰色	Light Blueish			
[C 308]	灰色FS36375	Grey FS36375			
[C 317]	灰色FS36231	Grey FS36231			
[C 319]	浅松叶绿色	Light Pine Green			
[SM 03]	烧铁色	Metallic Burnt Iron			
[SM 07]	镜面银色	Plate Silver			
[MC 213]	不锈钢色	Stainless			