

Lockheed P-80A/B

SW 72041 scale: 1/72



The airplane had its origin in June 1943, when Lockheed was requested to design a fighter around the De Havilland turbojet engine developed in England in response to Germany's twin-engine jet fighter, the Messerschmitt Me 262. It was flown for the first time on January 8, 1944, and its performance was very good. The USAAF planned to build the Shooting Star in large numbers. Four were sent to Europe for operational testing (two to England and two to the 1st Fighter Group at Lesina Airfield, Italy) but when test pilot Major

Frederic Borsodi was killed in a crash caused by an engine fire on 28 January 1945, in the cockpit of 44-83026 at RAF Burtonwood, the P-80A was temporarily grounded. Because of the delay the Shooting Star saw no combat in World War II. Anyway production continued, but in smaller Scale.

The first unit equipped by P-80 was 412th Fighter Group located on March Field in autumn 1945.

In 1947 P-80 changed its name to F-80, because newly independent USAF redesignated F (as fighter) to P (as pursuit).

Lockheed built 917 F-80A's and B's, one of which was modified for an attempt on the world speed record. On June 19, 1947, this plane achieved a speed of 623.8 miles per hour. Some of these modifications were retained in the F-80C, later used in Korean war in ground attack role, being superseded by F-84 and F-86 in later stages.

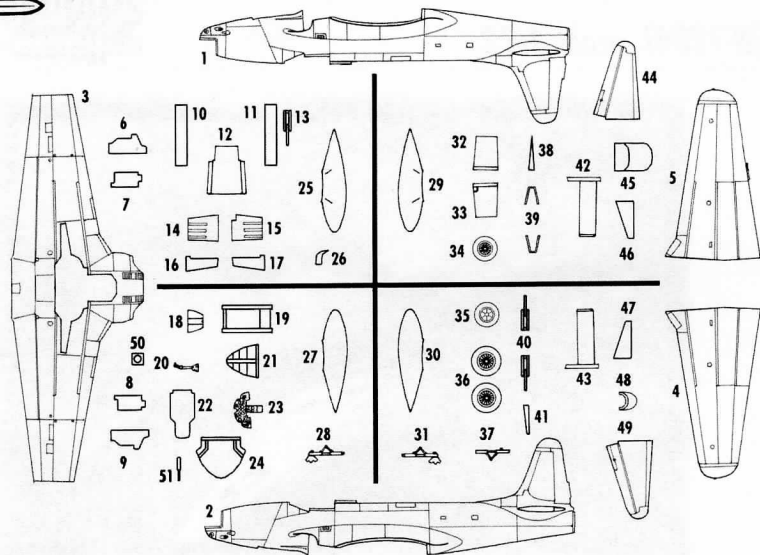

BARVA/COLOR	
A	Černá/Black
B	Interierová zelená/ Zinc chromate
C	Stříbrná/Silver
D	Hliník/Aluminium
E	Světle šedá/ Light Grey
F	Červená/Red
G	Žlutá/Yellow
H	Zelená/Green
I	Černošedá/ Tyre Black
J	Špinavý hliník/ Dirty Aluminium
K	Chromová/ Chrome
L	Hnědá/Brown
M	Kovová/Gun metal

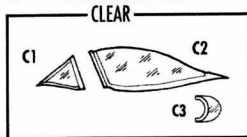
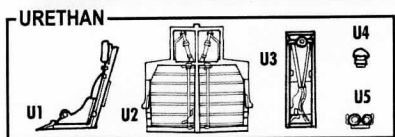

info

P-80A



SCRATCH BUILD

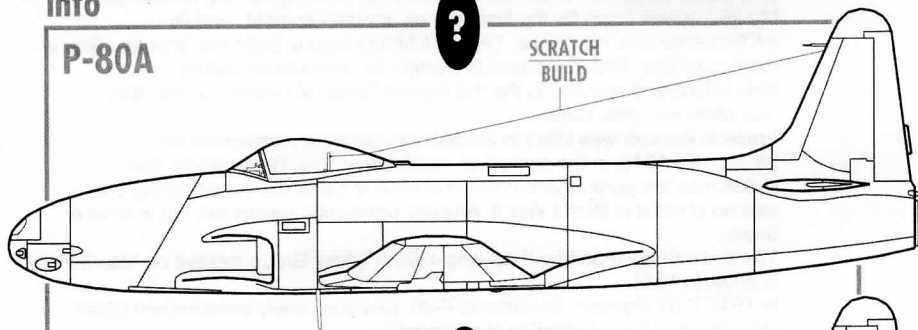

P-80B

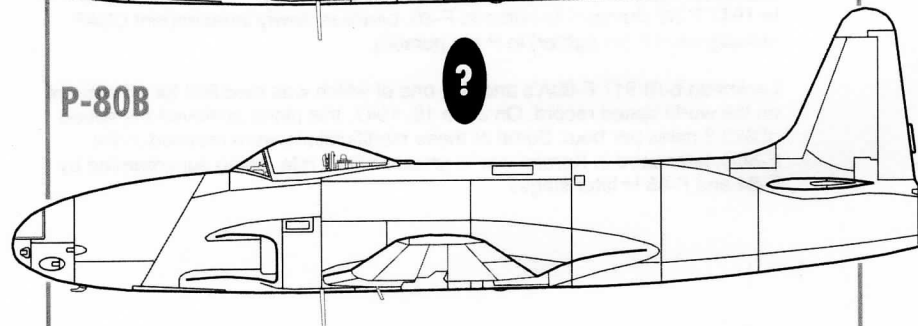

★ STEP

P-80A ? P-80B

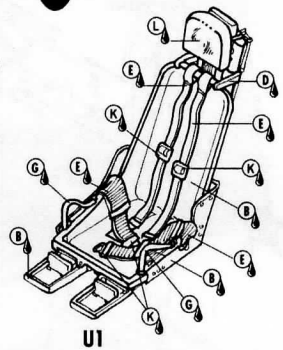
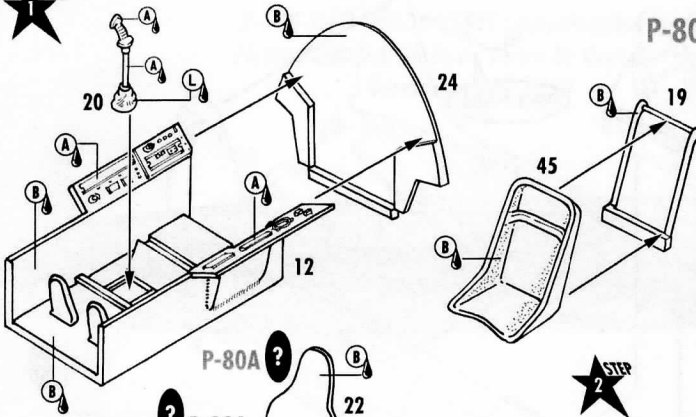

★ STEP 2

P-80A ? P-80A

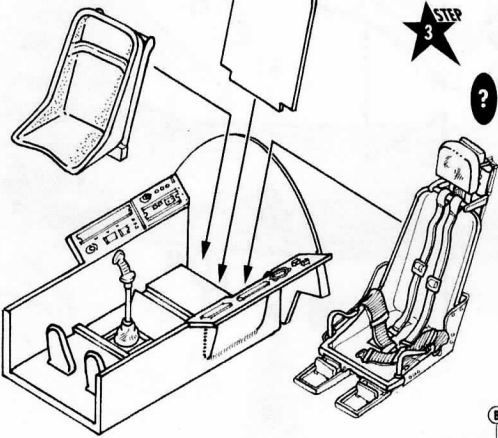

★ STEP 3

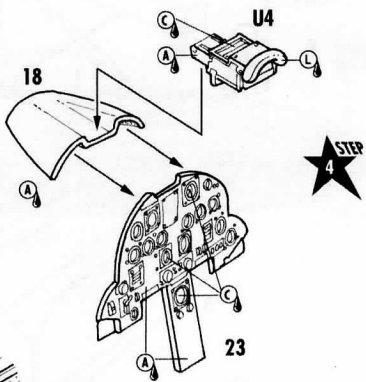

★ STEP 4

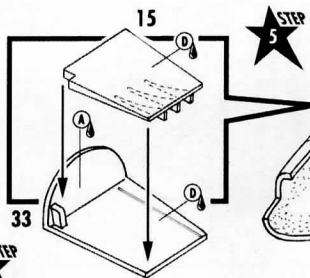

★ STEP 5

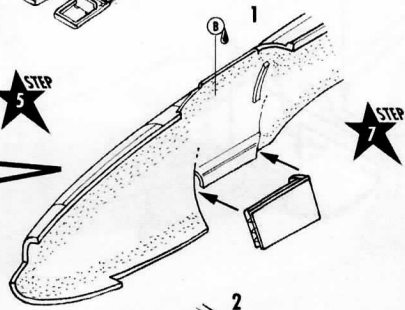

★ STEP 7

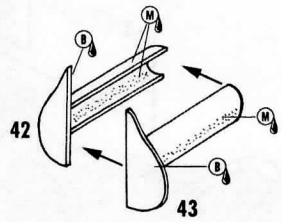

★ STEP 9

★ STEP 6

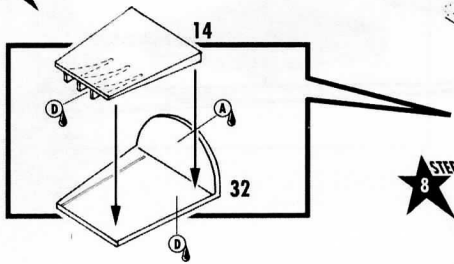

★ STEP 8

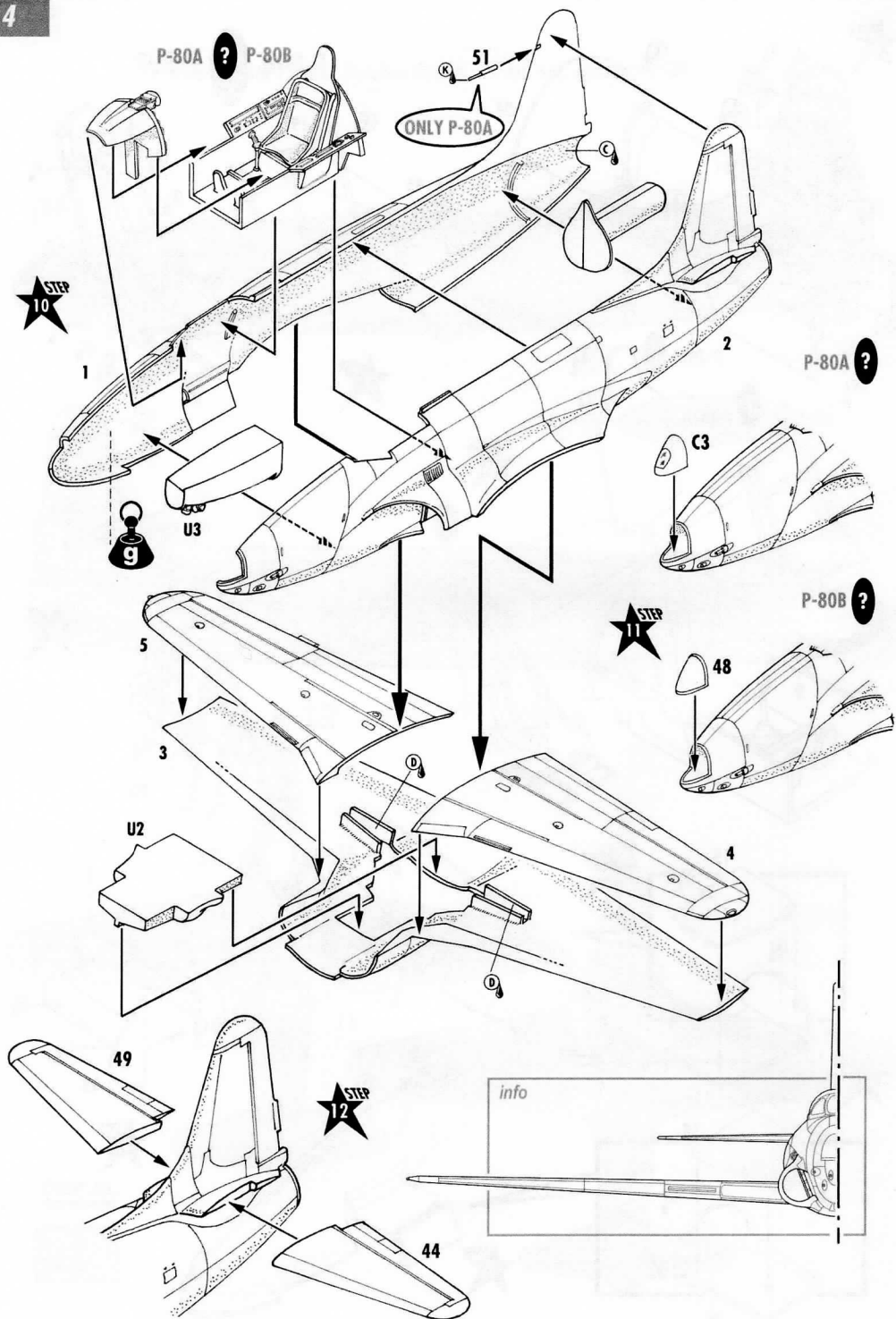

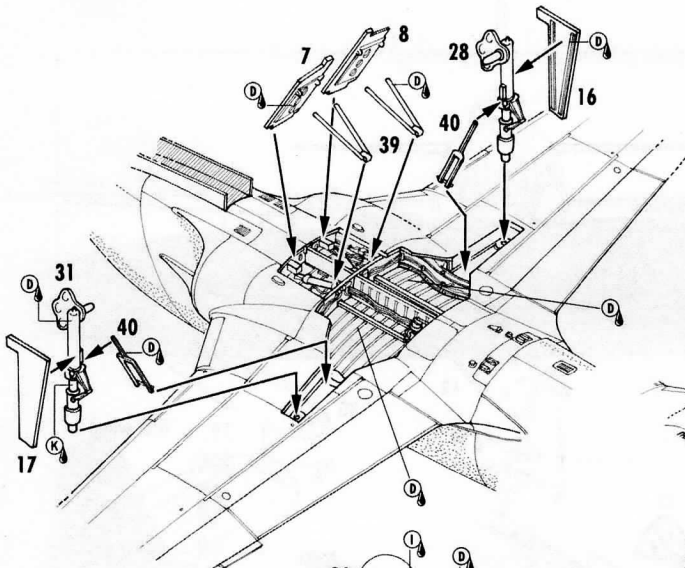

★ STEP 13

P-80A ?

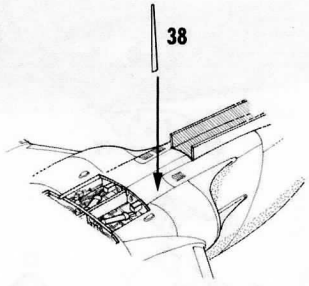

★ STEP 14

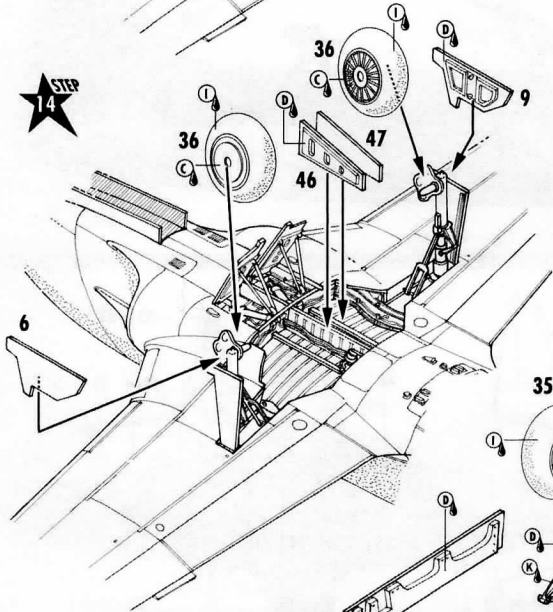

★ STEP 15

P-80B ?

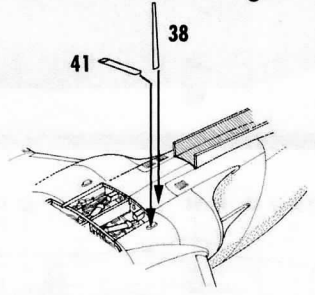

★ STEP 16

ONLY P-80B

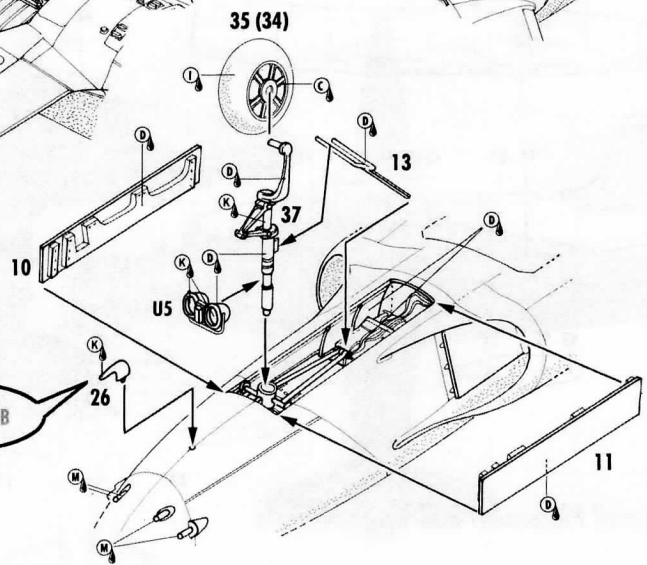

11

info

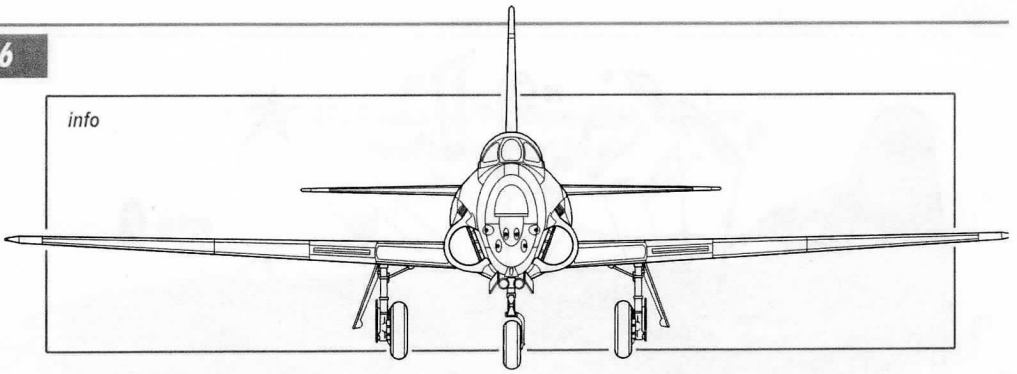

★ STEP 17

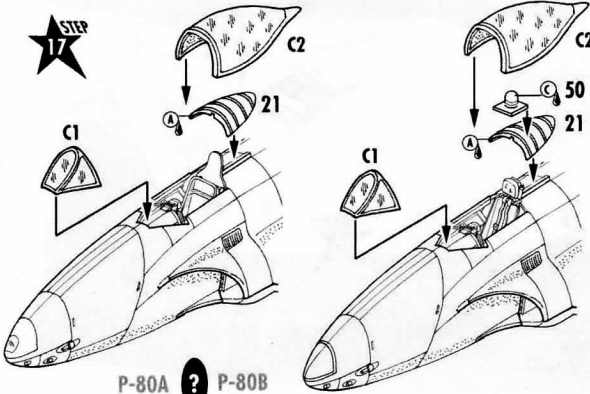

P-80A ? P-80B



★ STEP 18

(right wing)

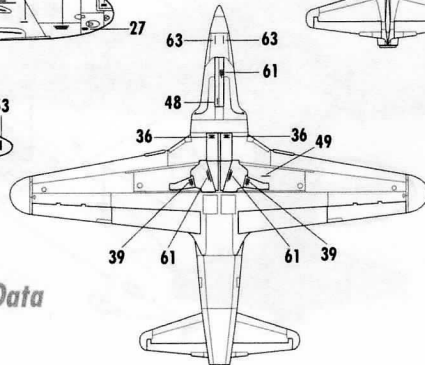
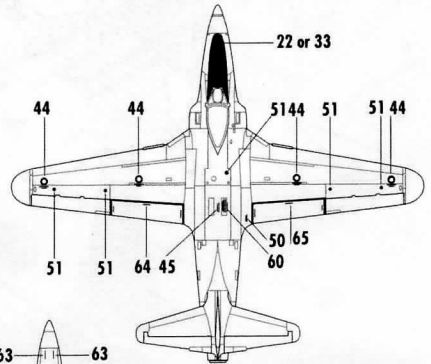
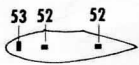
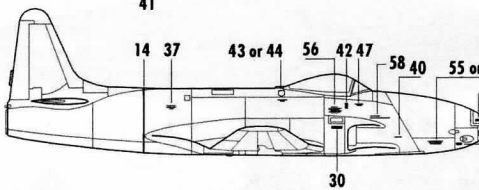
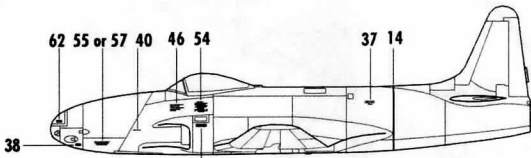
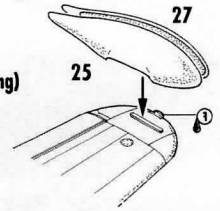

Stencil Placement and Common Data

P-80A 31st Fighter Group, June 1945, Italy

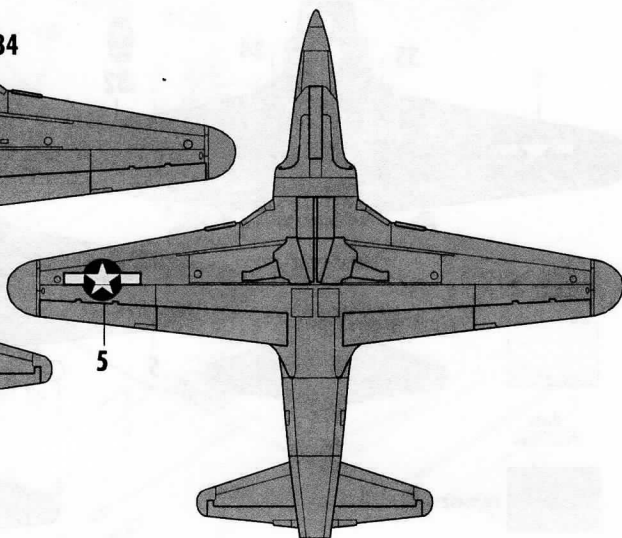
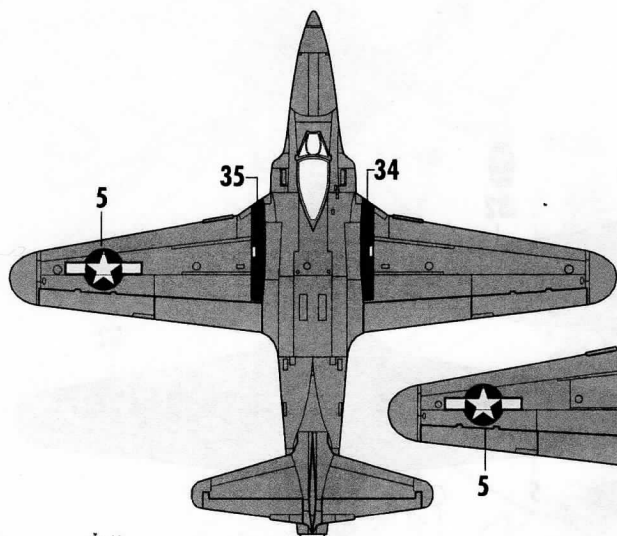
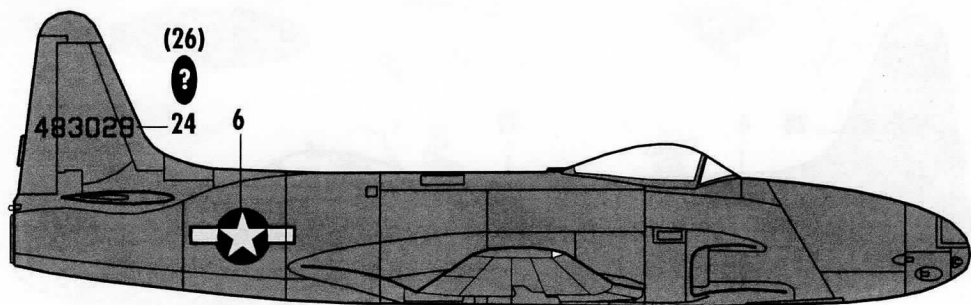
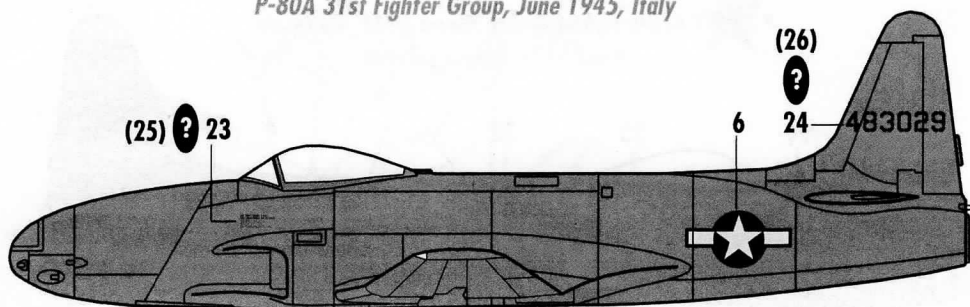

Šedá
Pearl Grey



FS 16492

*P-80A-1 412th Fighter Group, March 1946, California
flown by Lt. Robert Eckman*

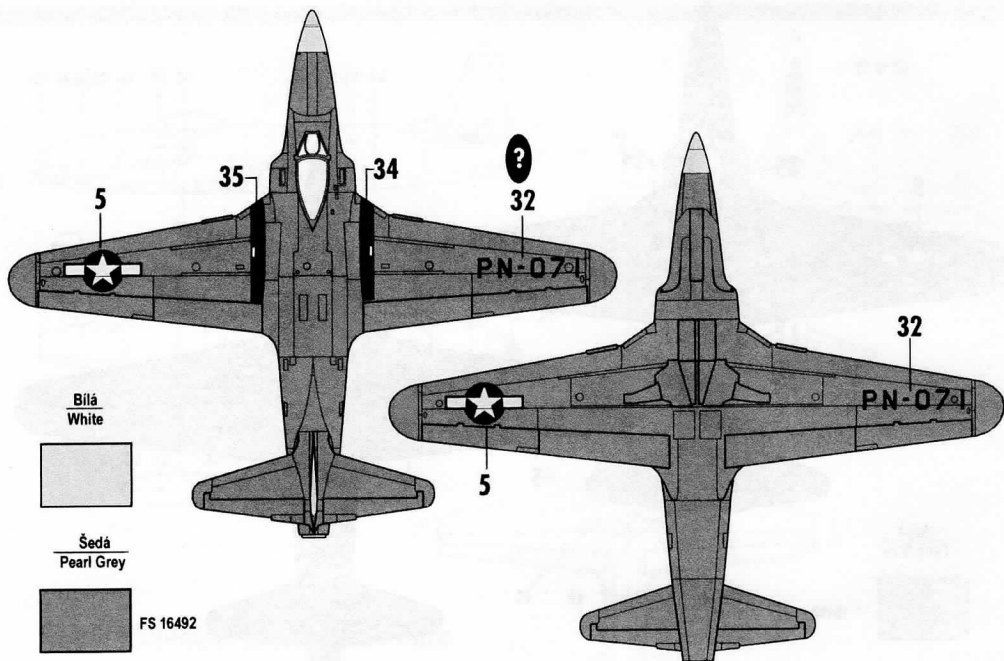
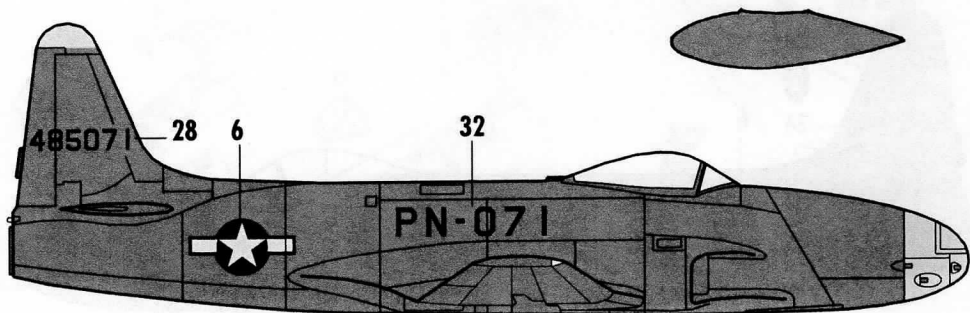
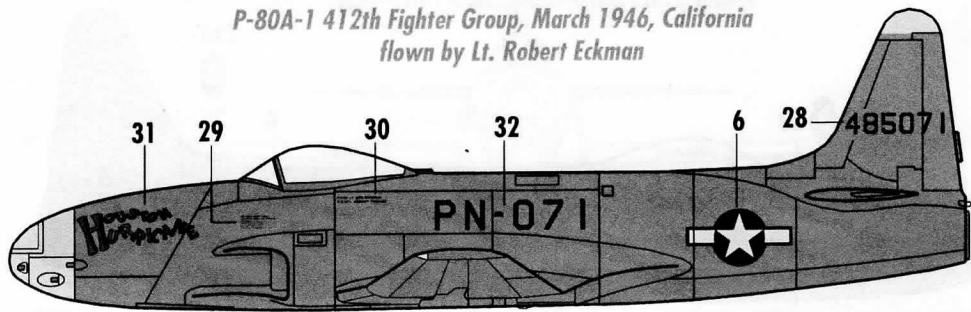

*F-80B-1-LO Official USAFE Demonstration Team,
Fürstenfeldbrück Air Base, flown by Capt. Gordon,
Germany 1949-1950*

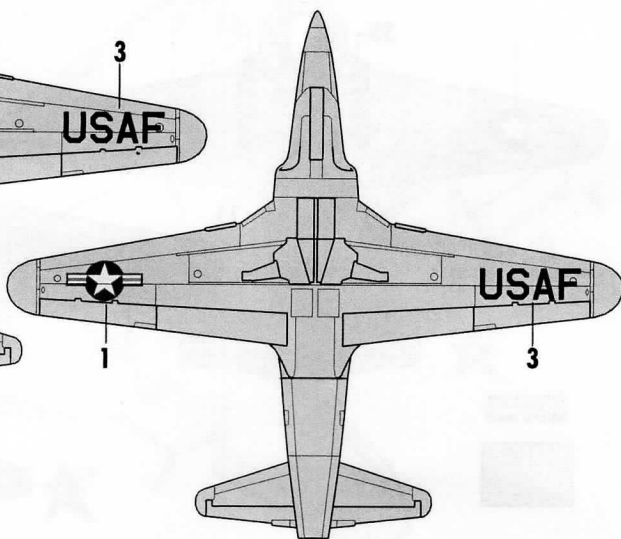
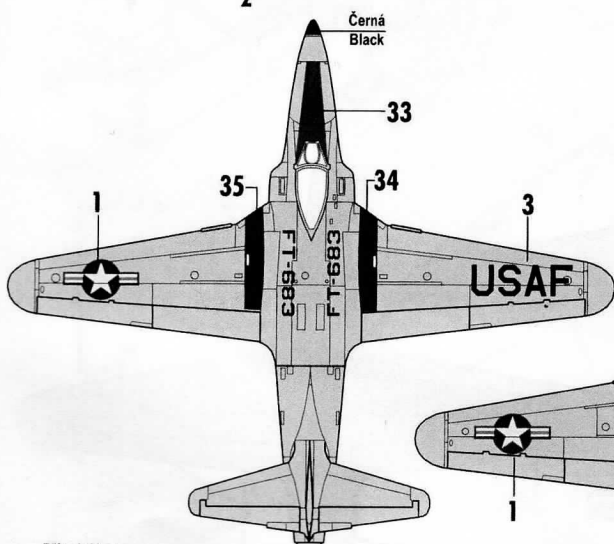
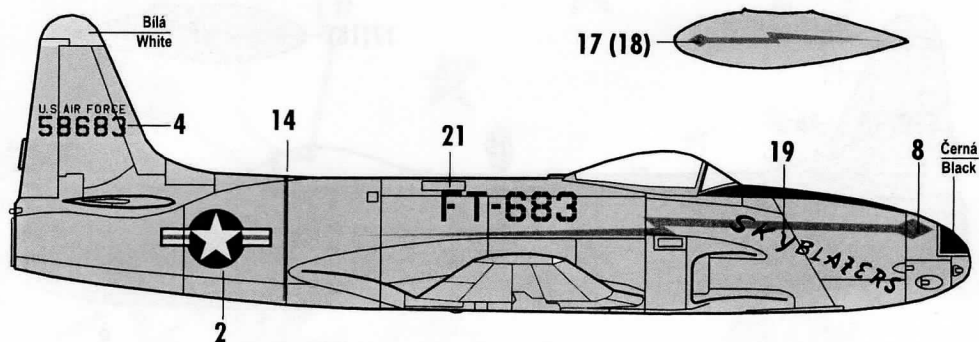
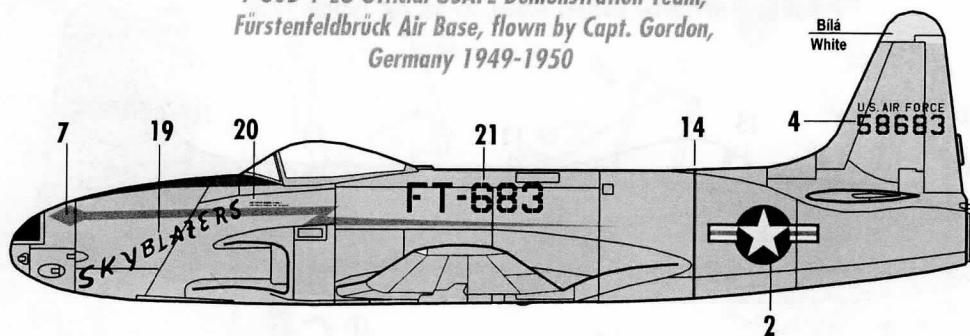

Přirodní kov
Natural metal



P-80B-1 36th Fighter Bomber Group, 22 nd. sq., Europe 1950

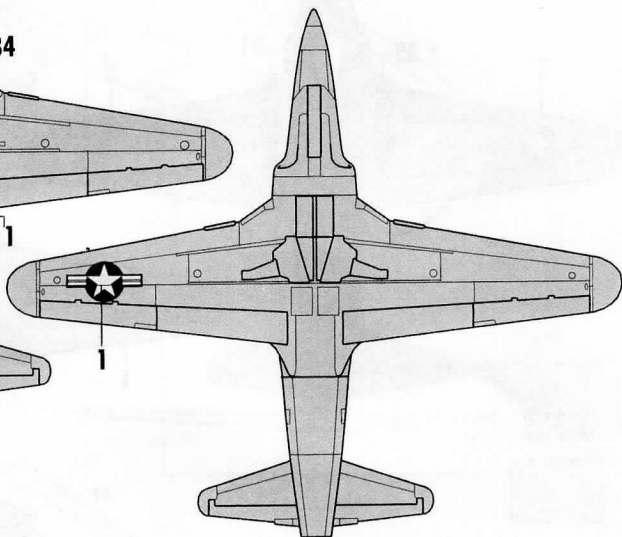
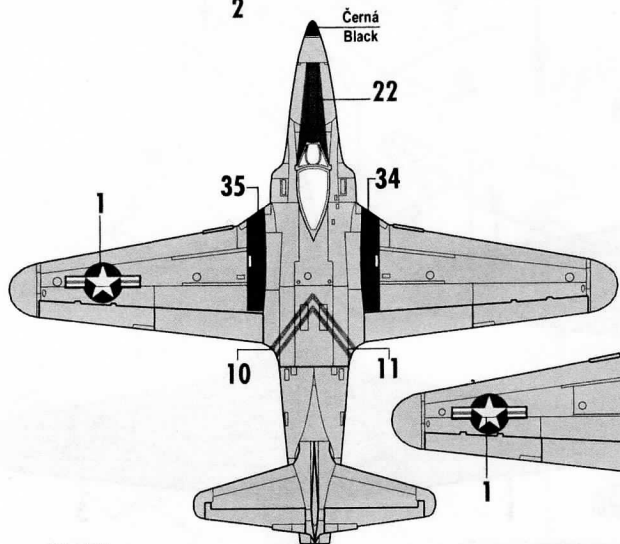
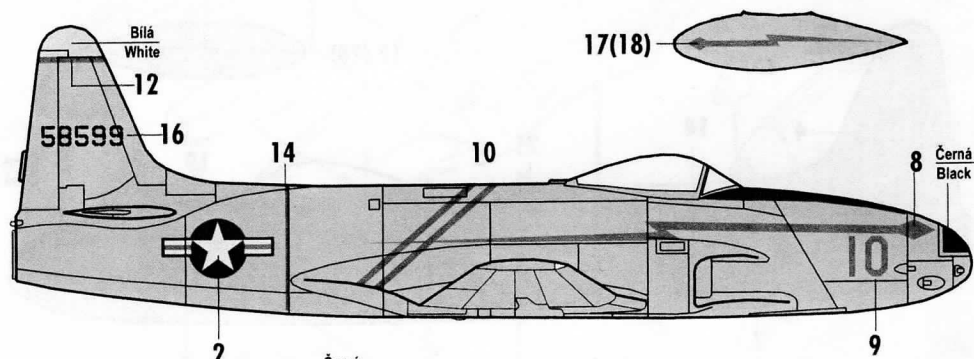
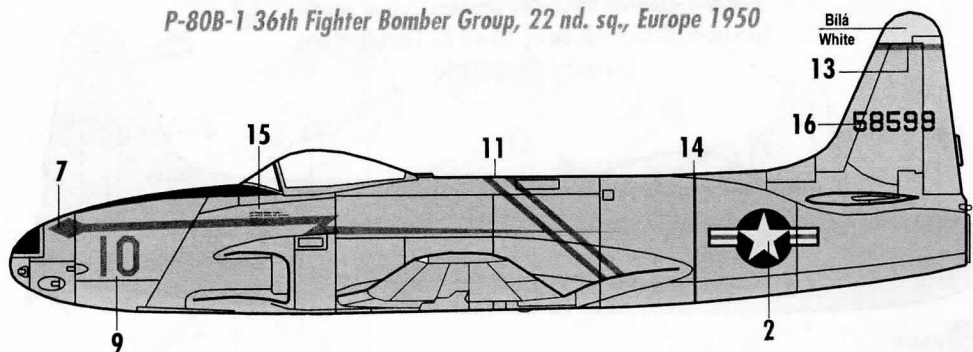

Přirodní kov
Natural metal





1



USAF

U.S. AIR FORCE
58683



5



2



USAF

U.S. AIR FORCE
58683



6



7



17



8



18

10 10

9

10

11



14



12



13

58599

58599

16

19

SKYBLAZERS

SKYBLAZERS

20

FT-683

FT-683

22

24

483029

483029

25

483028

26

483028

485071

28

485071

31

PN-071

32

PN-071



33

15

ALL THESE SYMBOLS APPLY TO ALL TYPES OF MARKINGS ON AIRCRAFT AND AIRCRAFT PARTS. THEY ARE NOT TO BE USED FOR OTHER PURPOSES.

34



WALK WAY

35



WALK WAY

21

HOUSTON HURRICANE

ALL THESE SYMBOLS APPLY TO ALL TYPES OF MARKINGS ON AIRCRAFT AND AIRCRAFT PARTS. THEY ARE NOT TO BE USED FOR OTHER PURPOSES.

ALL THESE SYMBOLS APPLY TO ALL TYPES OF MARKINGS ON AIRCRAFT AND AIRCRAFT PARTS. THEY ARE NOT TO BE USED FOR OTHER PURPOSES.

36	37	38	39	40	41	42	43	44	44	45	46	47
48	49	50	51	51	51	52	52	53	54	55	56	56
57	59	59	62	62	62	63	64	64	65	65	65	65
58	60	61	63	63	63	64	64	64	65	65	65	65



SW 72041 Lockheed P-80 A/B

Printed by Techmod

PN-071

32

PN-071

SW 72041 Lockheed P-80 A/B