

涂装同标贴指示

Painting & Marking guide

XF59 DESERT YELLOW
 XF64 RED BROWN
 XF52 FLAT EARTH

PAINT REFERENCE COLOUR

Color	Mr.Hobby	Vallejo	Model Master	Tamiya	Humbrol	Color	Mr.Hobby	Vallejo	Model Master	Tamiya	Humbrol
Sandy Yellow 沙漠色	H 119	843	1735	XF59	63	Tire Black 胎黑色	H 77 137	-	-	-	-
Brown 棕色	H 310 310	874	1742	-	118	Flat Black 黑(哑光)	H 12 33	950	1749	XF1	33
Red Brown 红棕色	H 47 41	984	-	XF64	160	Metal Black 黑铁色	H 18 28	864	1402	-	-

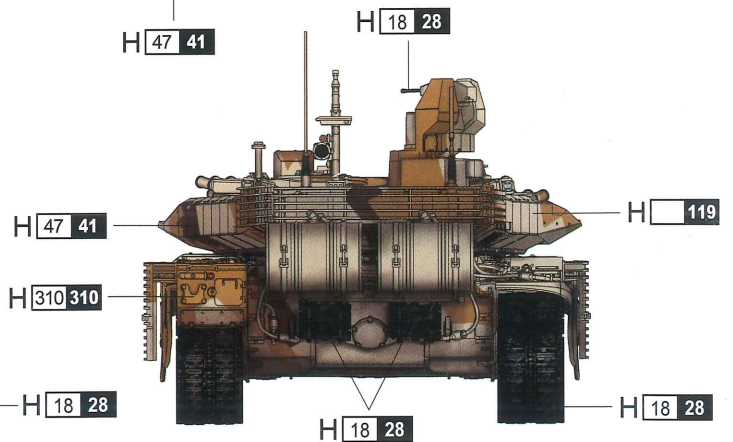
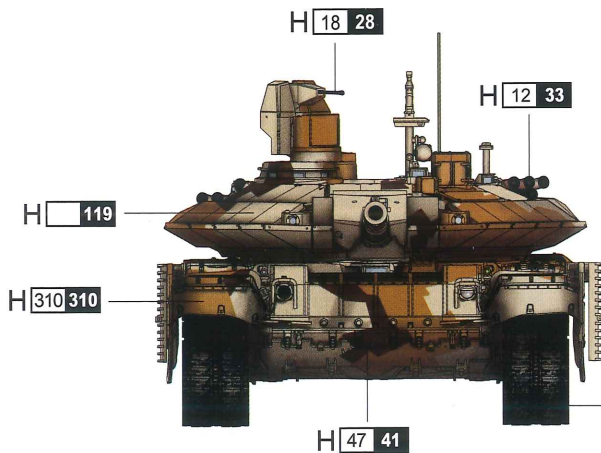
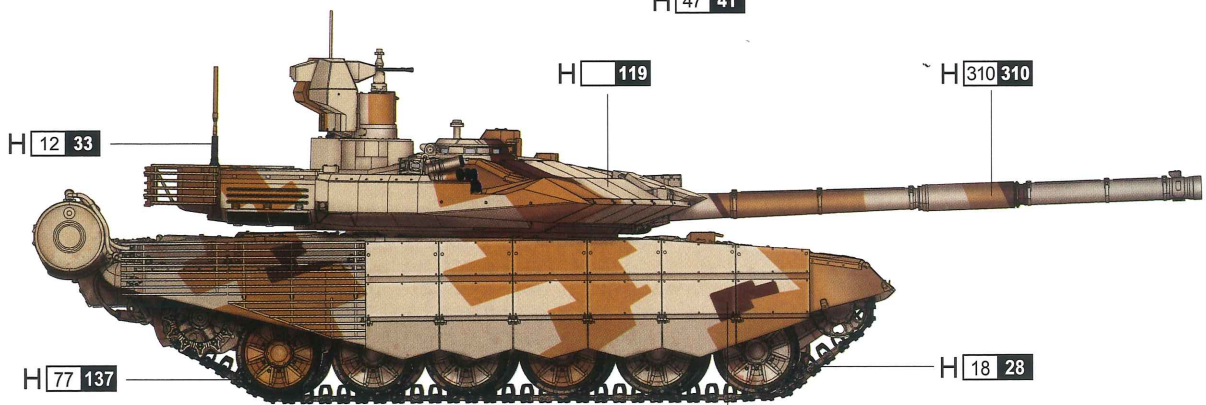
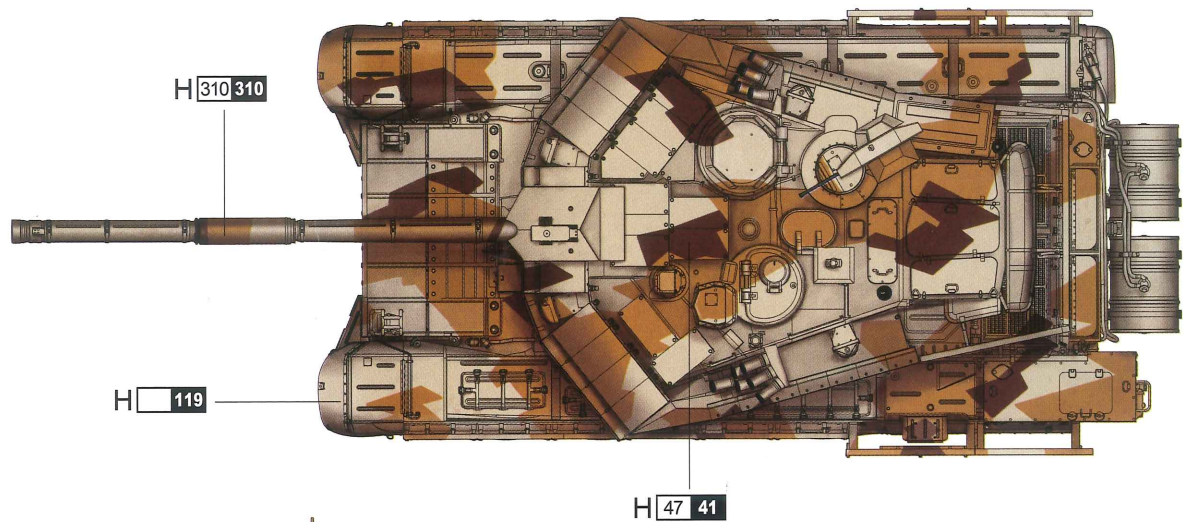
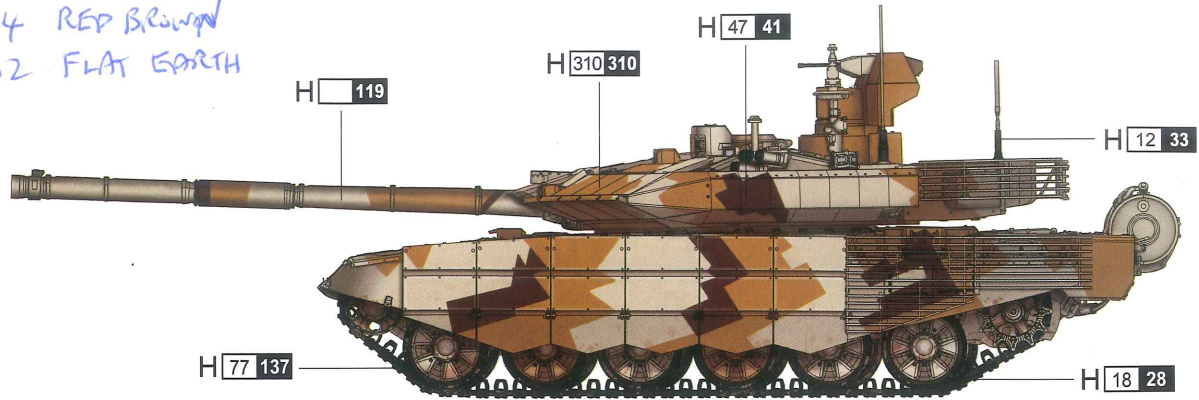

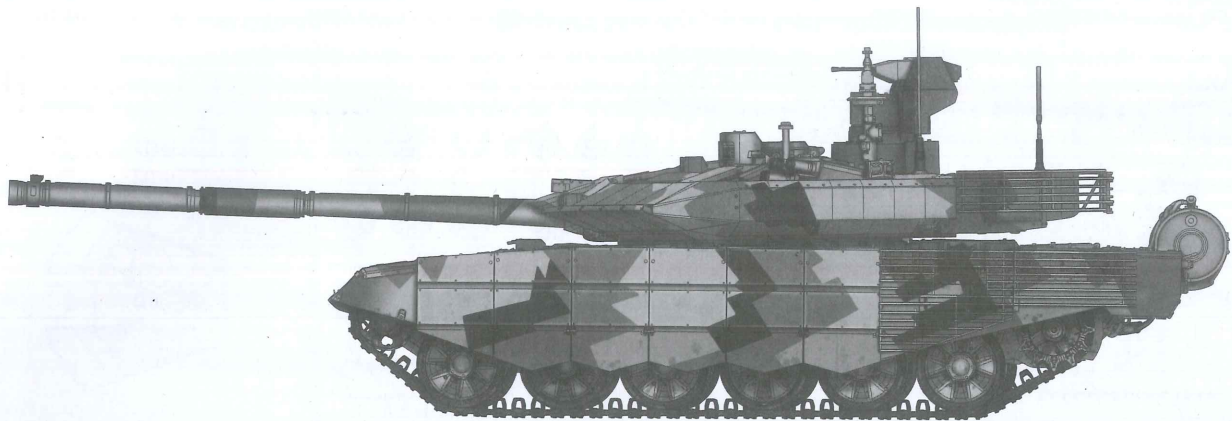

Russian T-90S MODERNIZED (Mod 2013)

俄罗斯T-90S主战坦克Mod 2013

READ BEFORE ASSEMBLY:

- Study and understand these instructions thoroughly before beginning assembly
- When needed, remove photo-etch parts carefully using a modeling knife or photo etch sprue cutter, being careful not to damage or lose small parts.
- Take extra care in handling photo etch parts in order to avoid injury
- Apply instant cement sparingly to photo etch parts where instructed
- Tools recommended(not included in kit):Plastic and instant cements, sprue cutters,long nose pliers,modeling knife, small files, tweezers, pin vise & scissors. Soft cloth and sandpaper will also assist in construction
- Glue and paint are not included in the kit. Use plastic cement and hobby paints only. Color guide for purchasing paint is included in the kit.

装配之前仔细阅读

- 小心用模型锉刀锉平所有零件表面的注射浇口。
- 小心用刀片切下蚀刻片零件，不要遗失小零件。
- 用强力快干胶水粘合蚀刻片零件和金属轴。过量快干胶水使用可能导致可动零件会粘住，小心涂胶。
- 取蚀刻片时应特别注意安全，防止利边划伤手指。
- 某些零件表面需贴水上贴纸，请选择在装配的同时进行。
- 推荐模型工具(自备)：胶水，水口剪刀，长咀钳，刀片，锉刀，镊子，钳，钻，剪刀，瞬间快干胶。
- 软布同砂纸同时也应该是必备工具。
- 请使用塑料胶水和油漆，模型内不含。



配重
Weight



使用强力胶
Cyanoacrylate glue



钻孔
Make hole



切除
Cut / Remove



贴纸
Decal



锉平
File / Sand



选择
Option



不涂胶水
No cement



弯曲
Bend



先装
Install it first

水贴纸的使用:

- 1.从水贴纸上剪下印花;
- 2.将印花放入温水中浸10秒，然后放在干净布上。
- 3.拿着印花纸板将印花移到模型上;
- 4.手指蘸水将印花移到适当的位置;
- 5.用软布轻压印花直至水干，气泡消失

DECAL APPLICATION

- 1.Cut decals from sheet as needed
- 2.Dip the decal in warm water for about 10 seconds and then place on soft clean cloth.
- 3.Hold the decal backing sheet edge and gently slide the decal onto the model in its proper position.

- 4.While still wet,decal can be adjusted for better fit on model by dampening it gently with your finger.
- 5.When placed in the proper position,gently press decal down with a soft cloth until excess water and air bubbles are gone.
- 6.Allow decal to dry completely before handling model

部品图
Parts

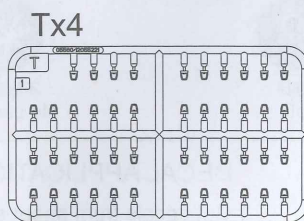
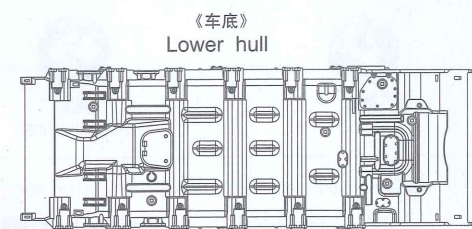
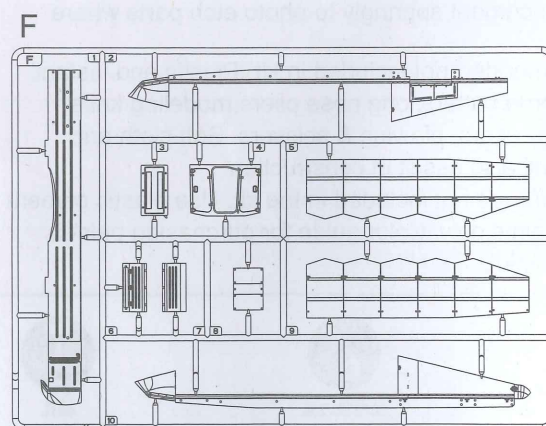
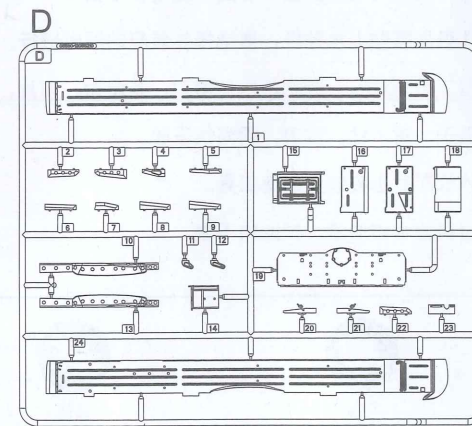
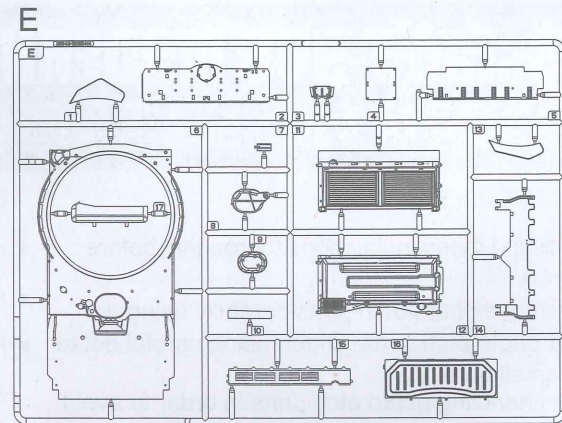
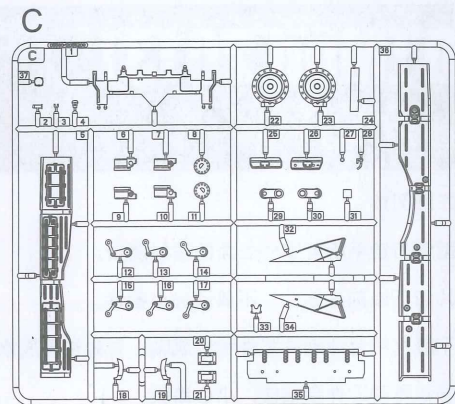
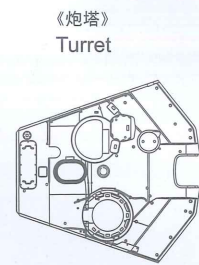
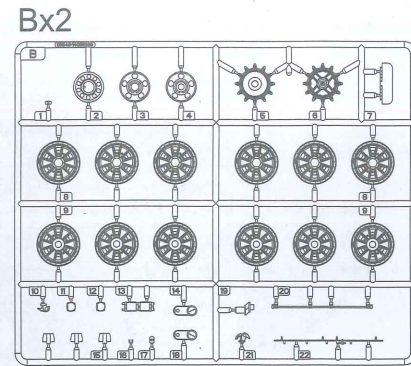
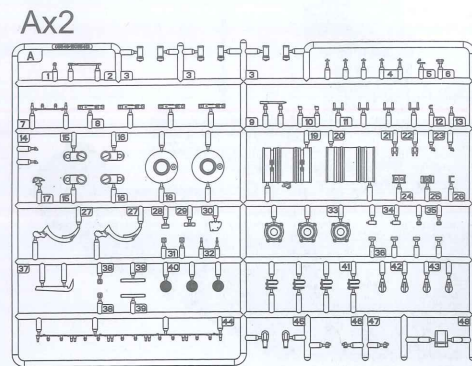

《铜丝》Ø0.6
Copper wire

《铜丝》Ø0.8
Brass wire

《软管》Ø1.2
Vinyl tubing

《轮塞》
Poly cap

部品图
Parts

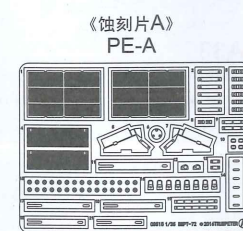
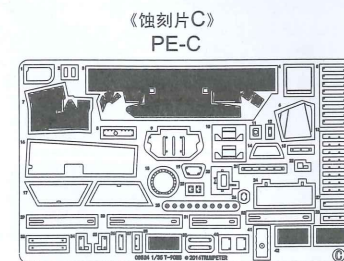
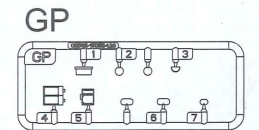
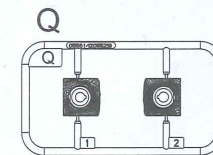
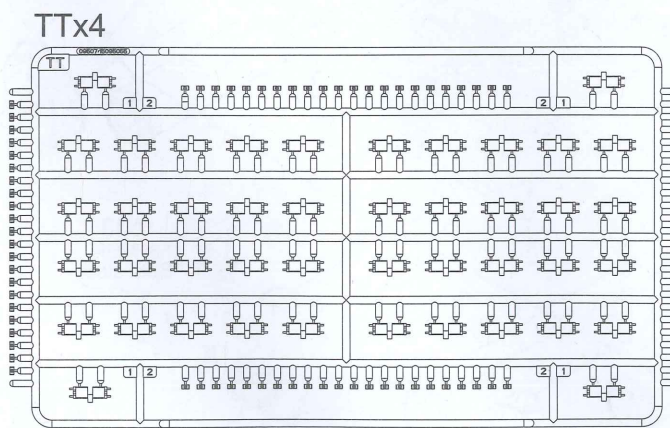
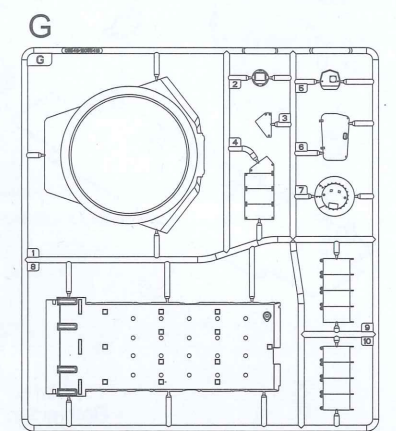
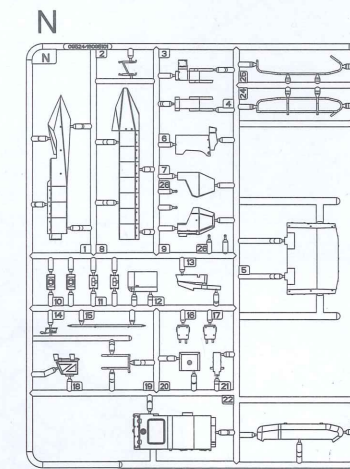
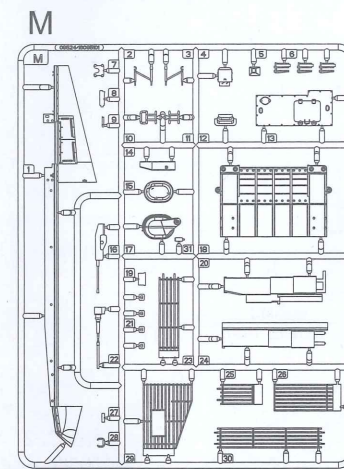
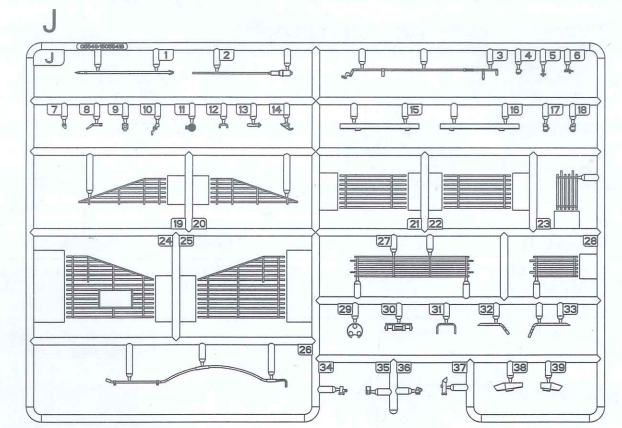
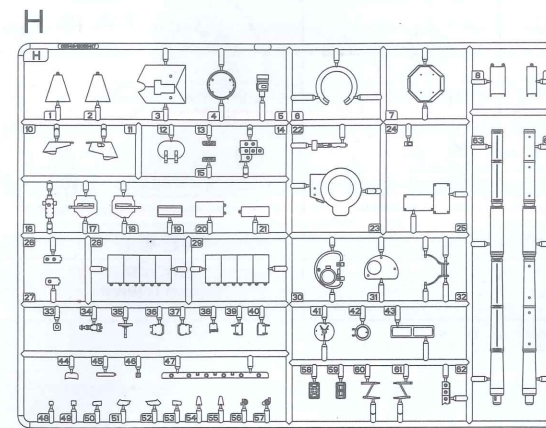

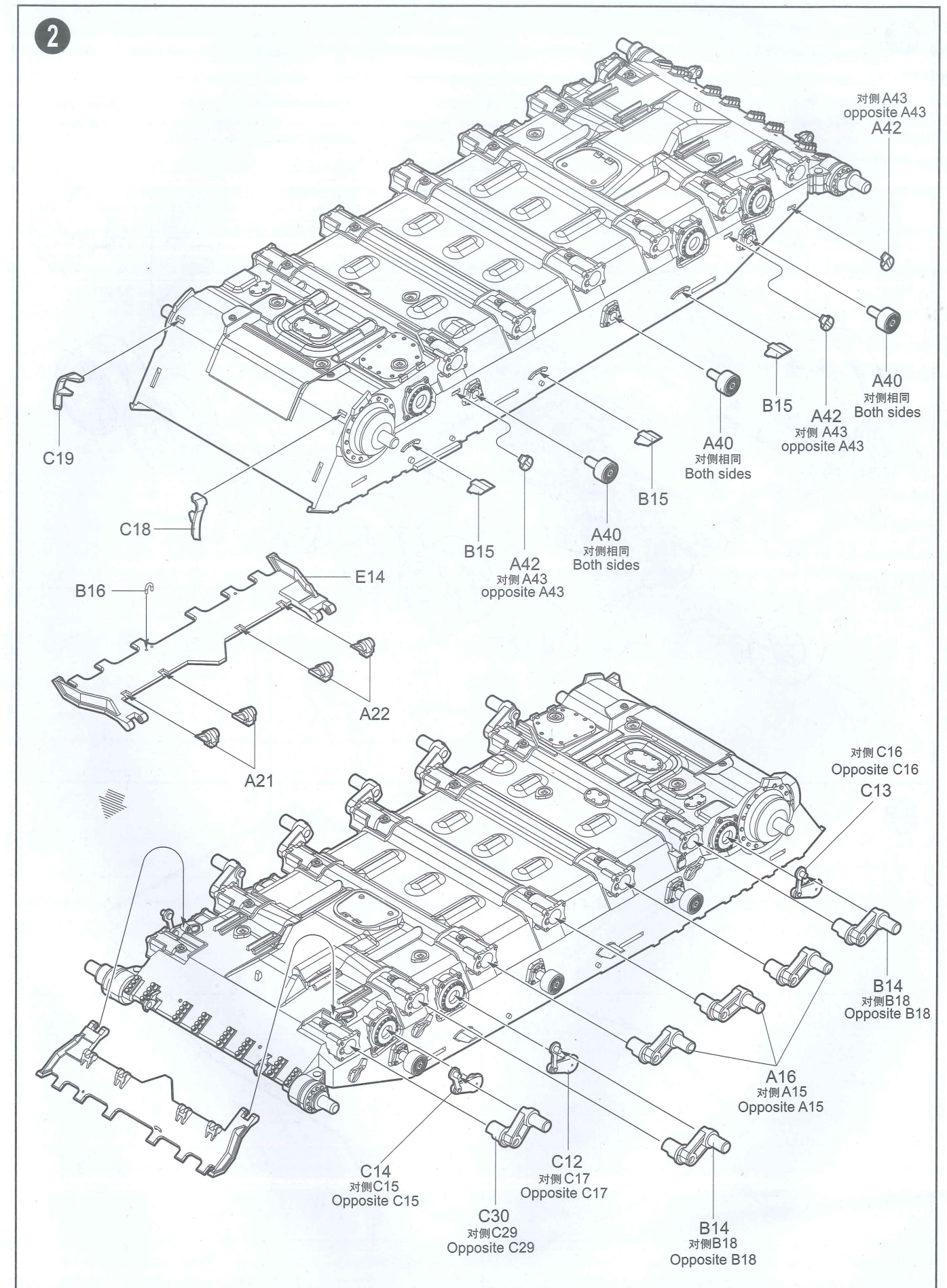
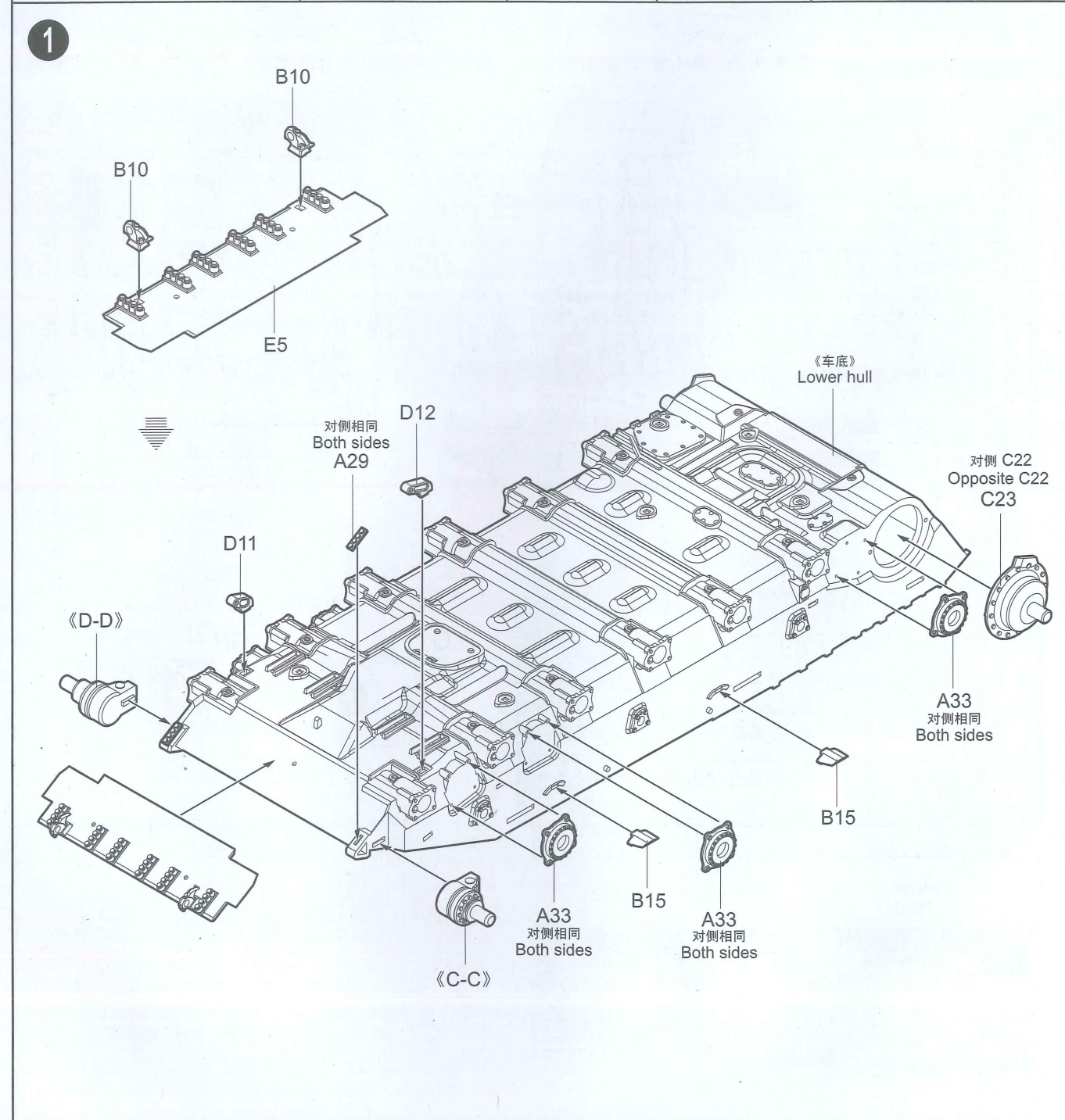
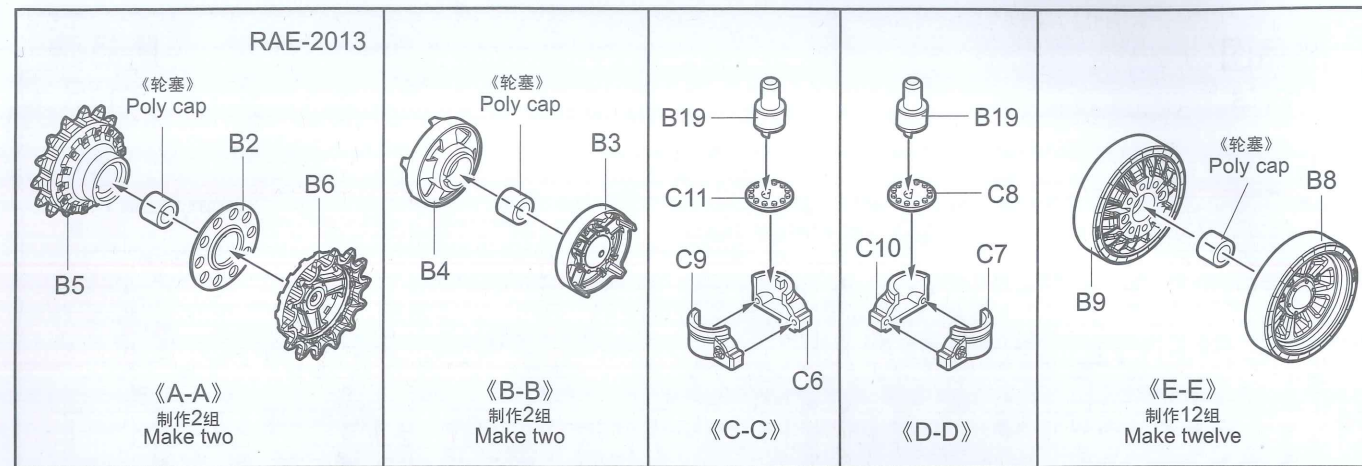

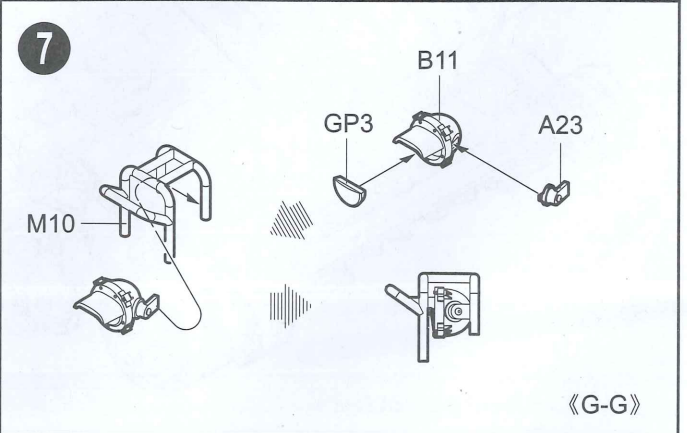
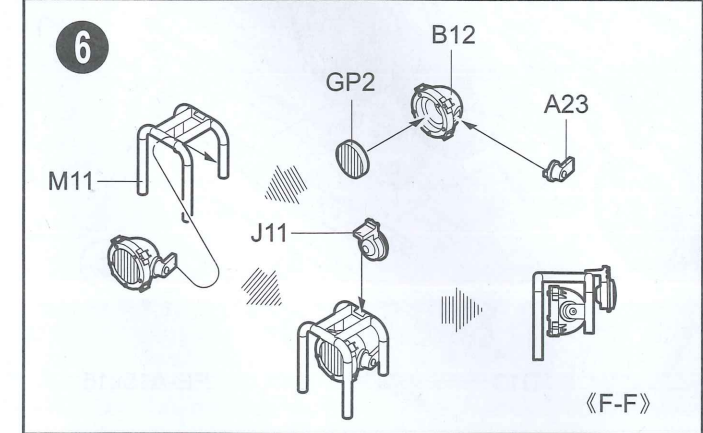
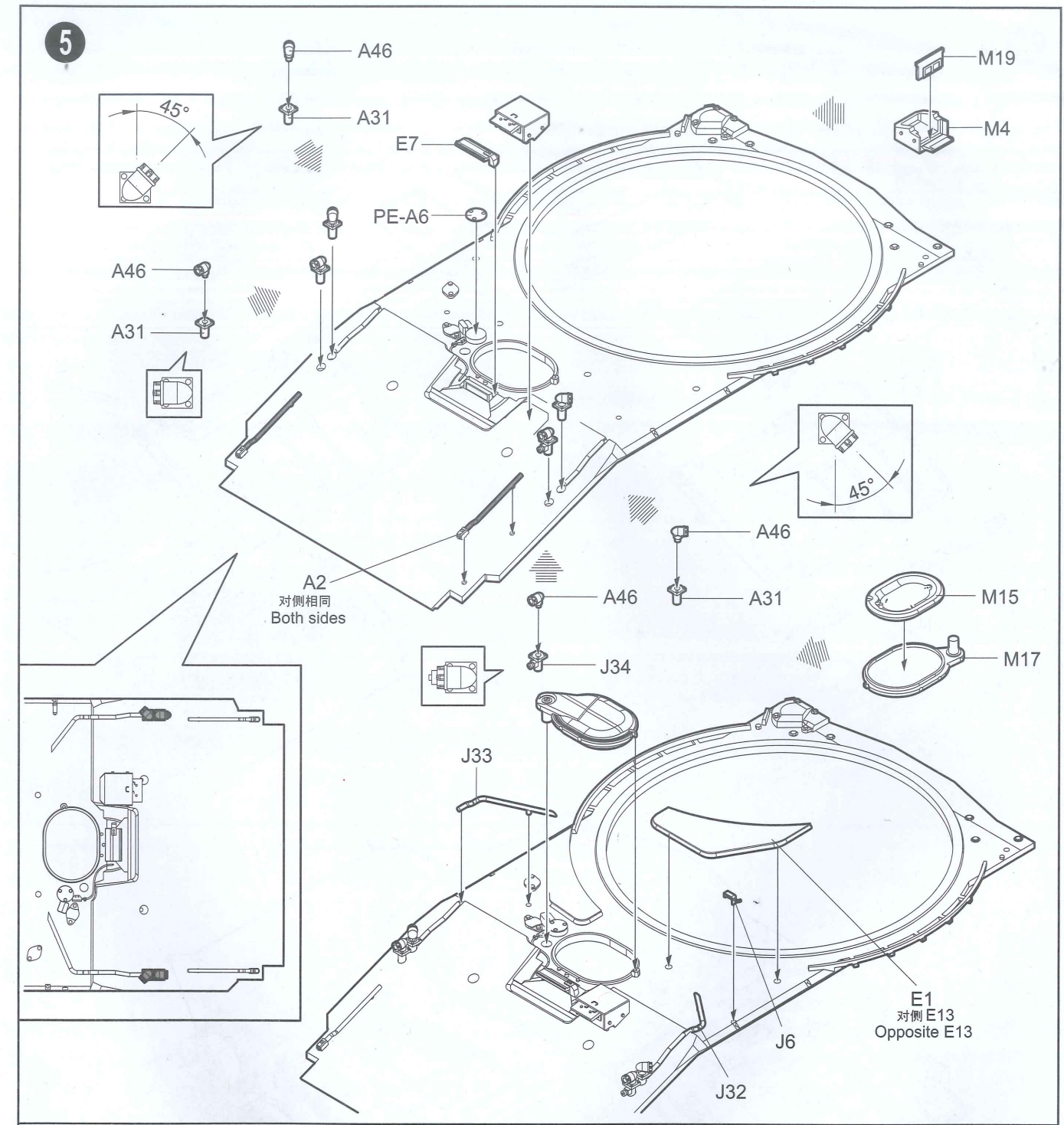
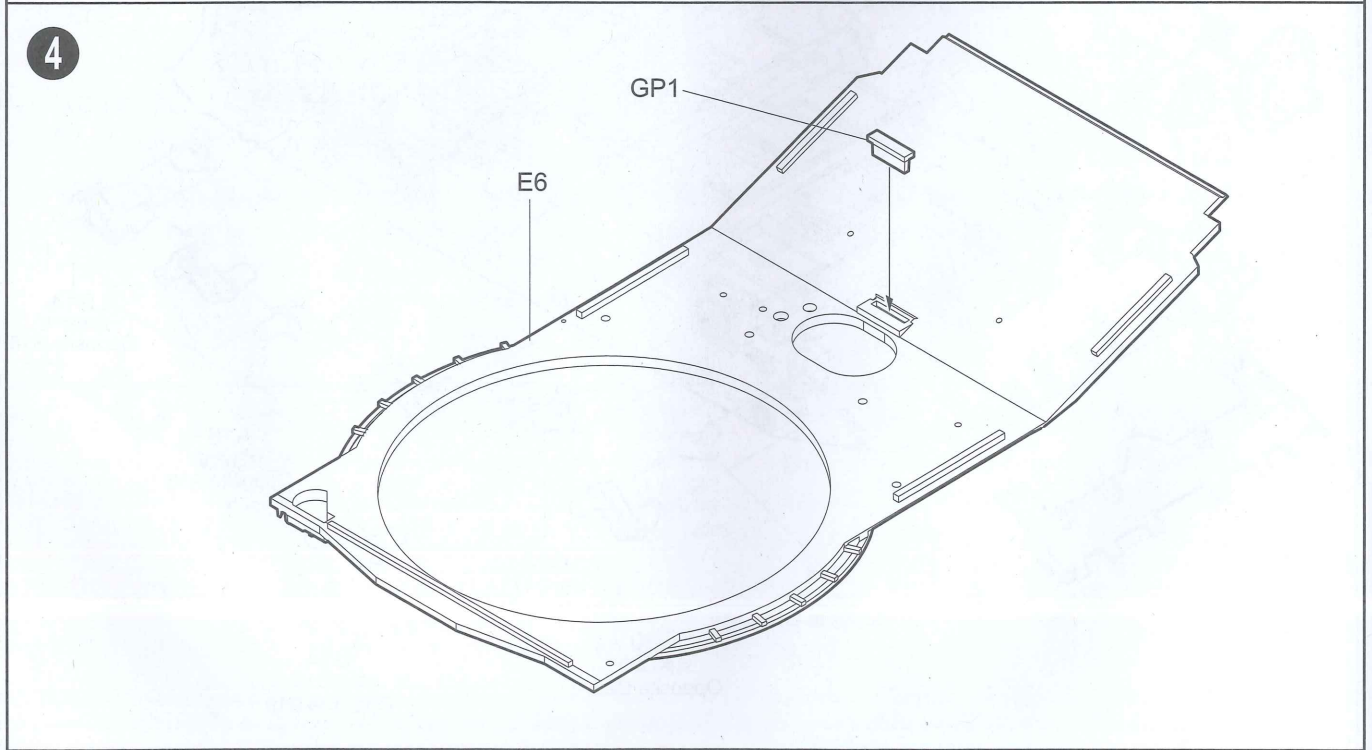
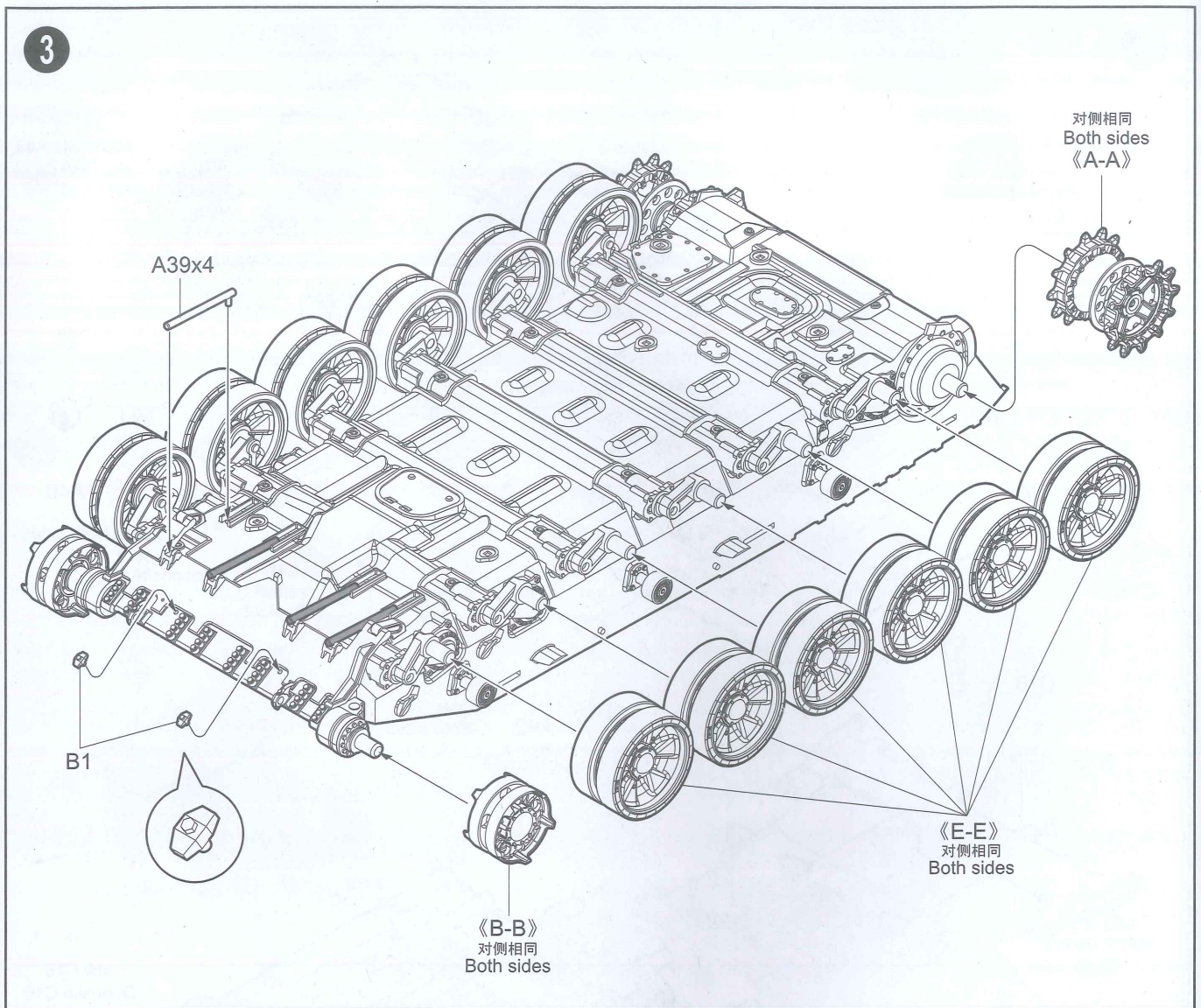

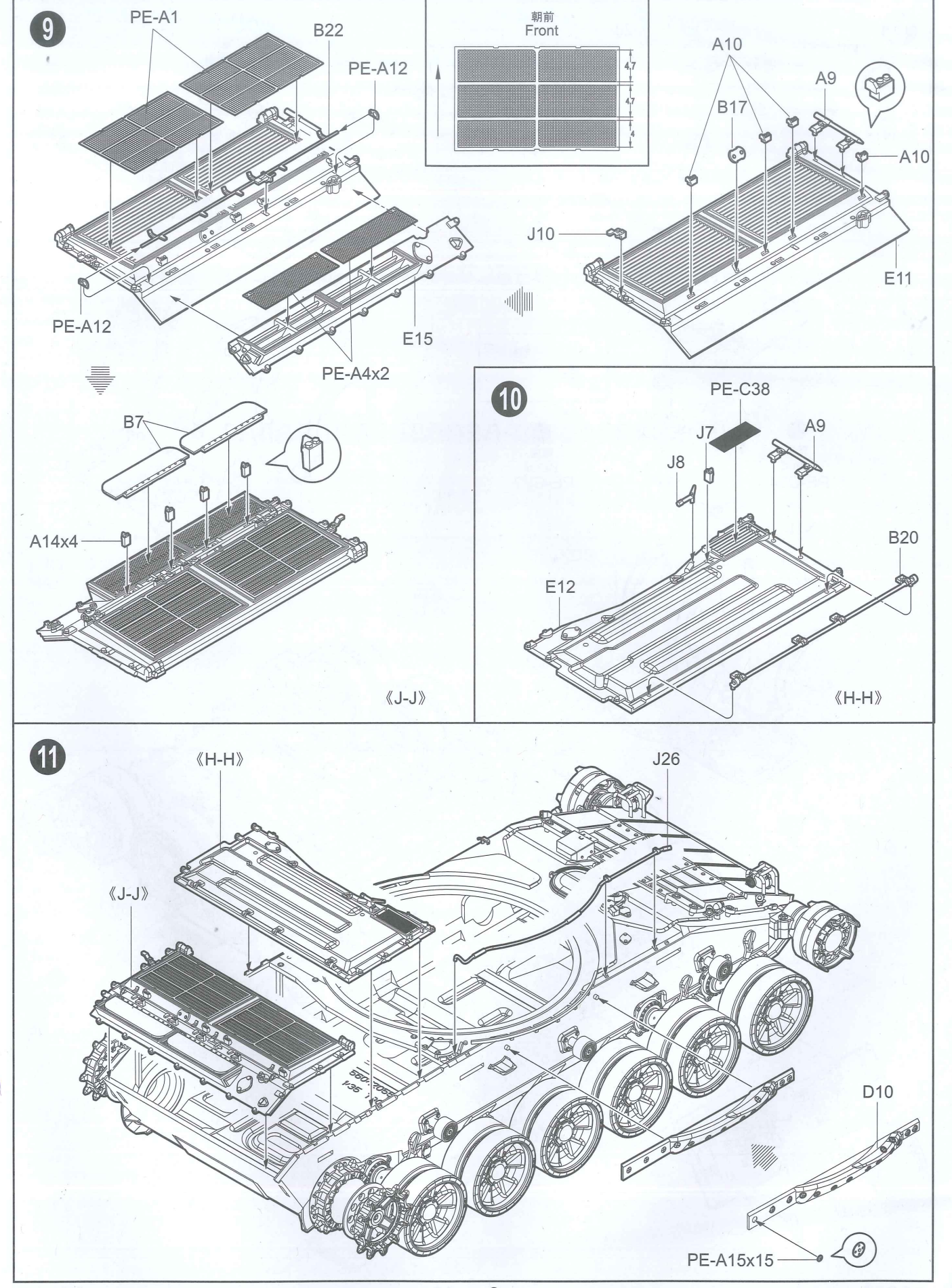
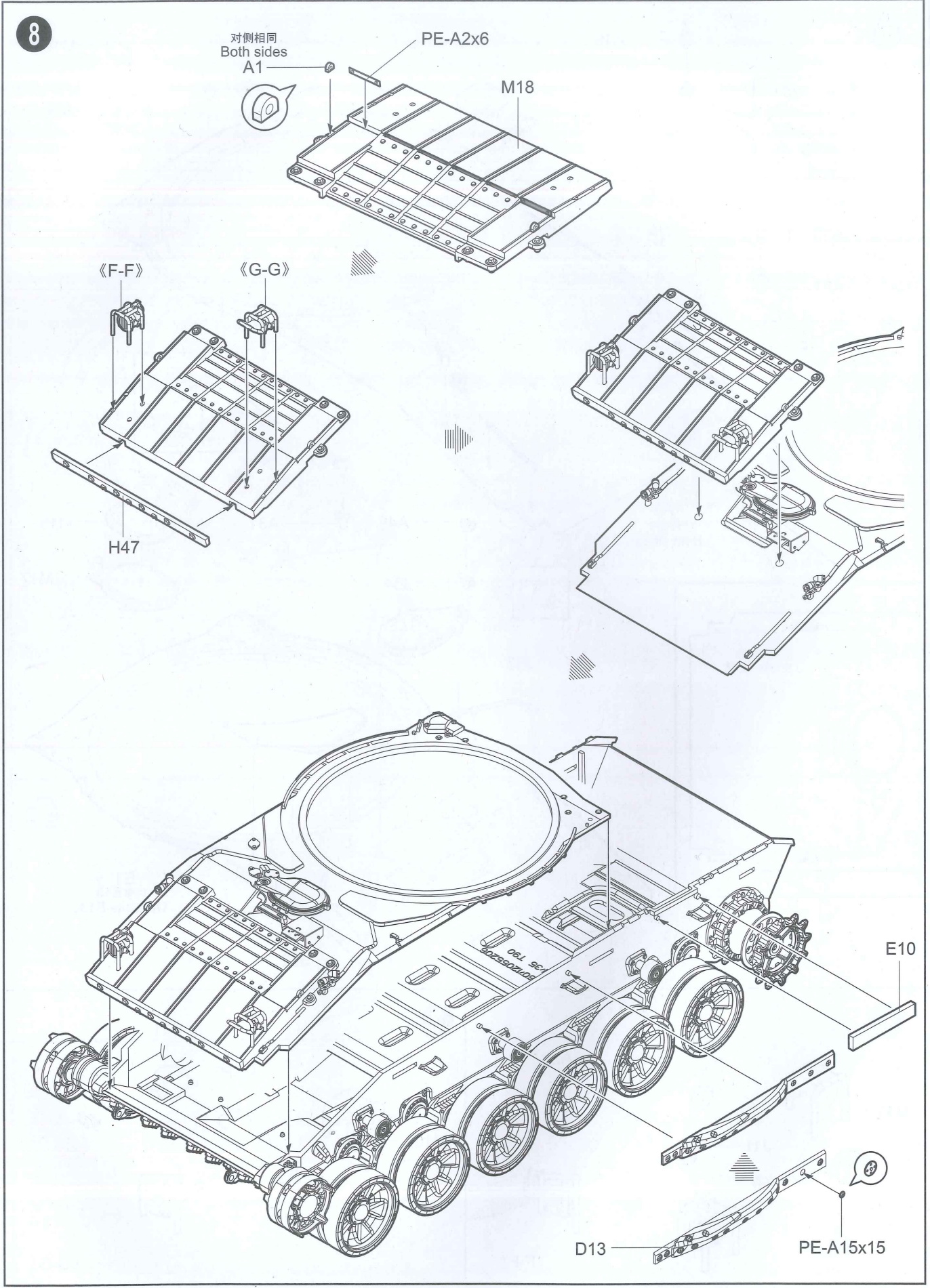

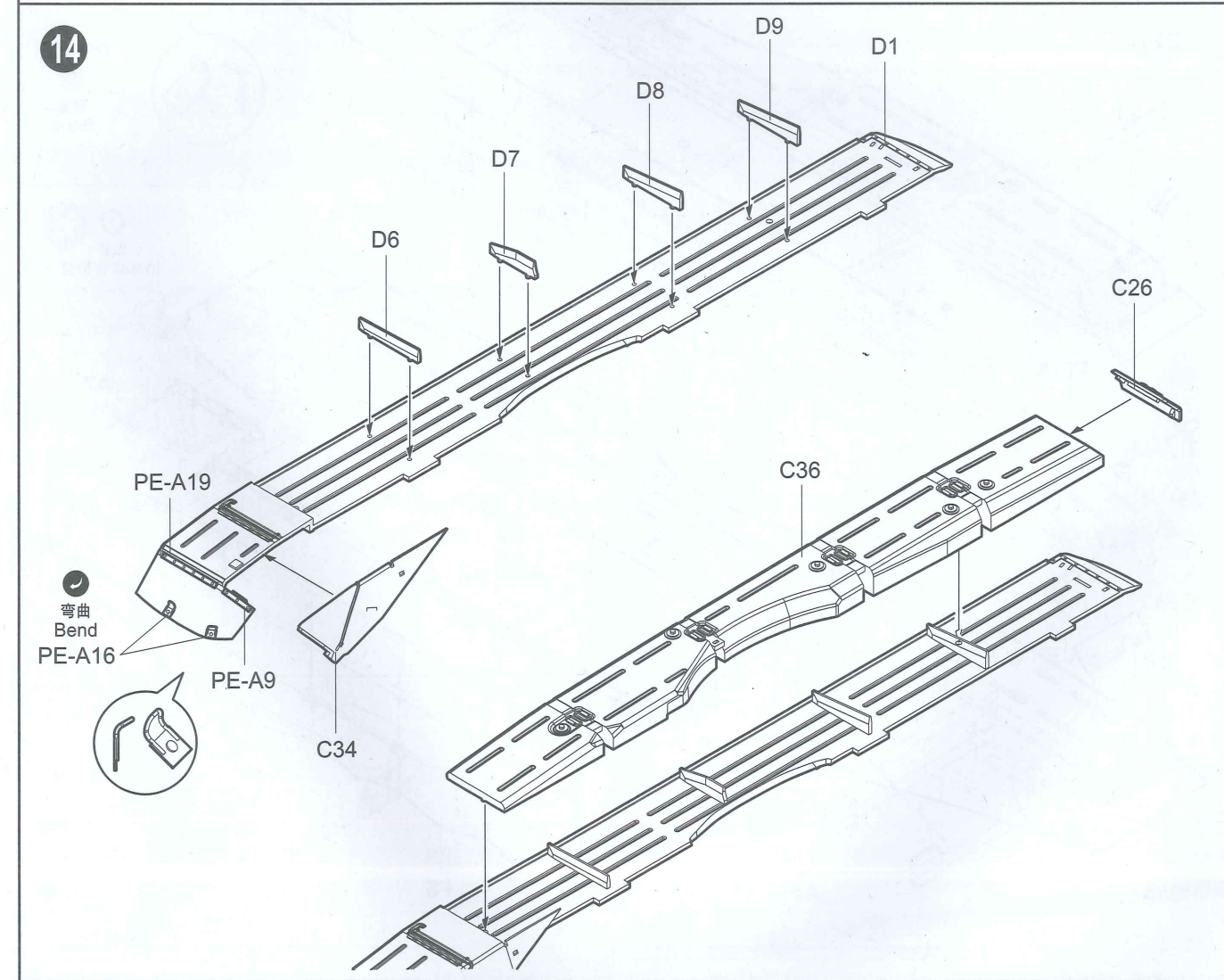
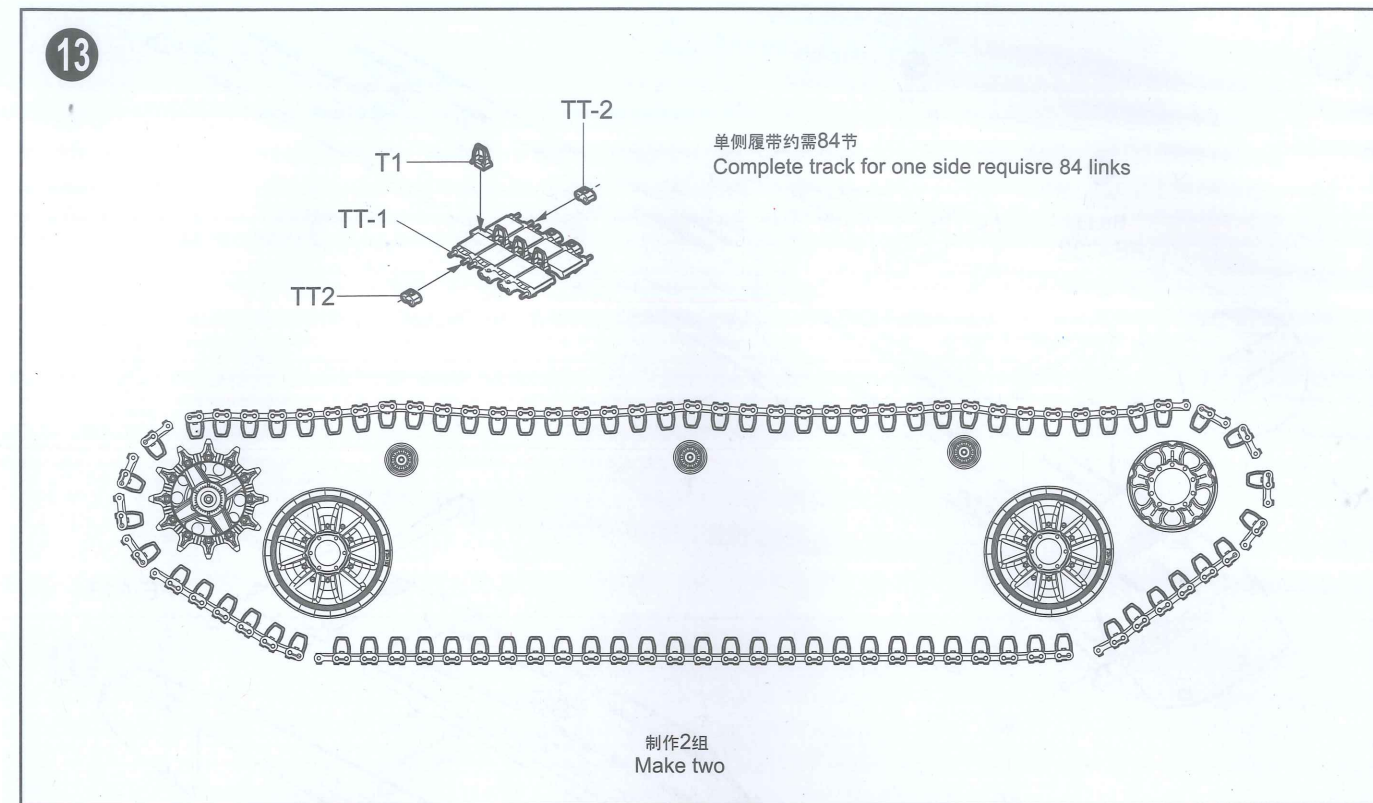
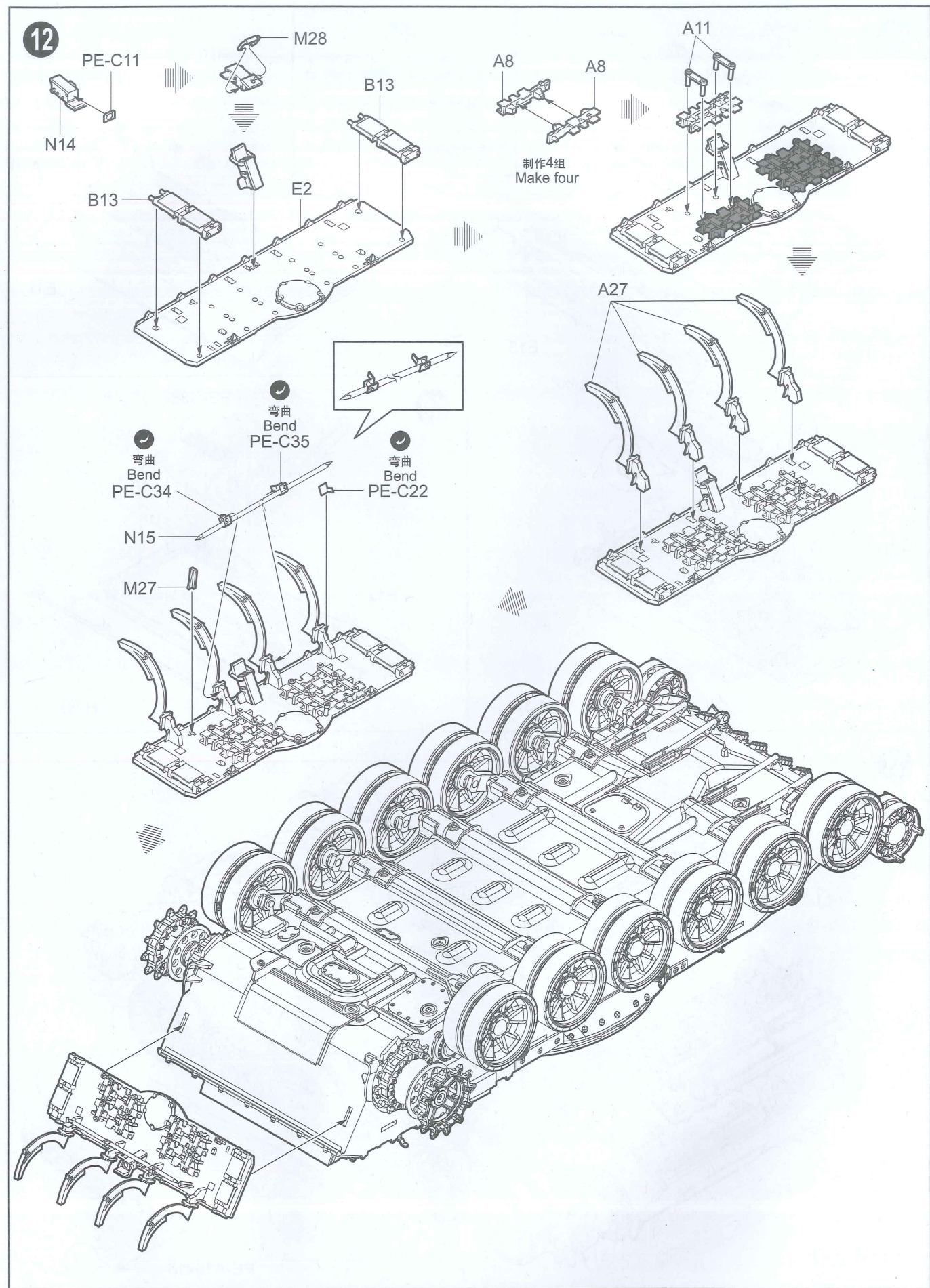

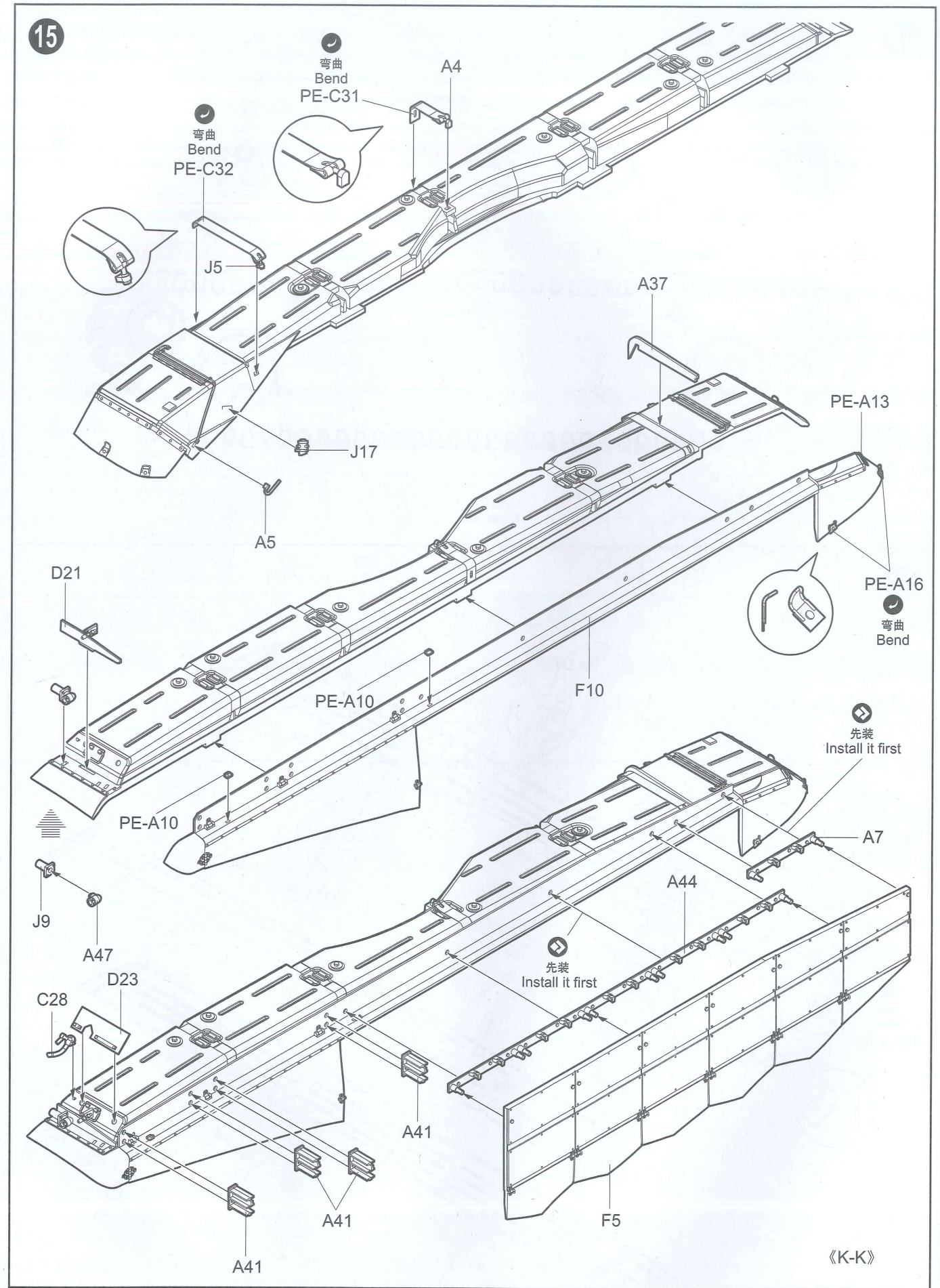

09524

12

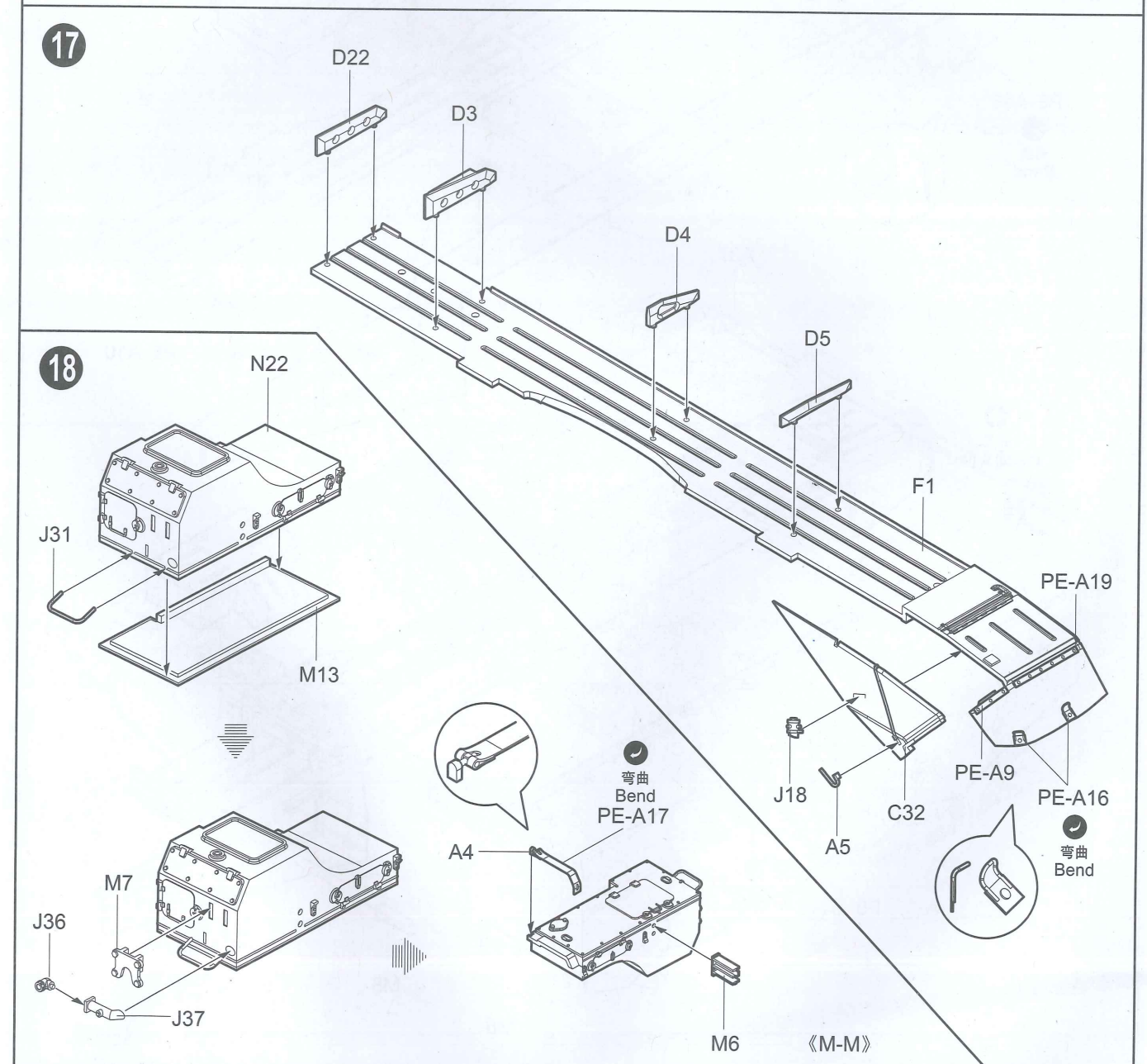
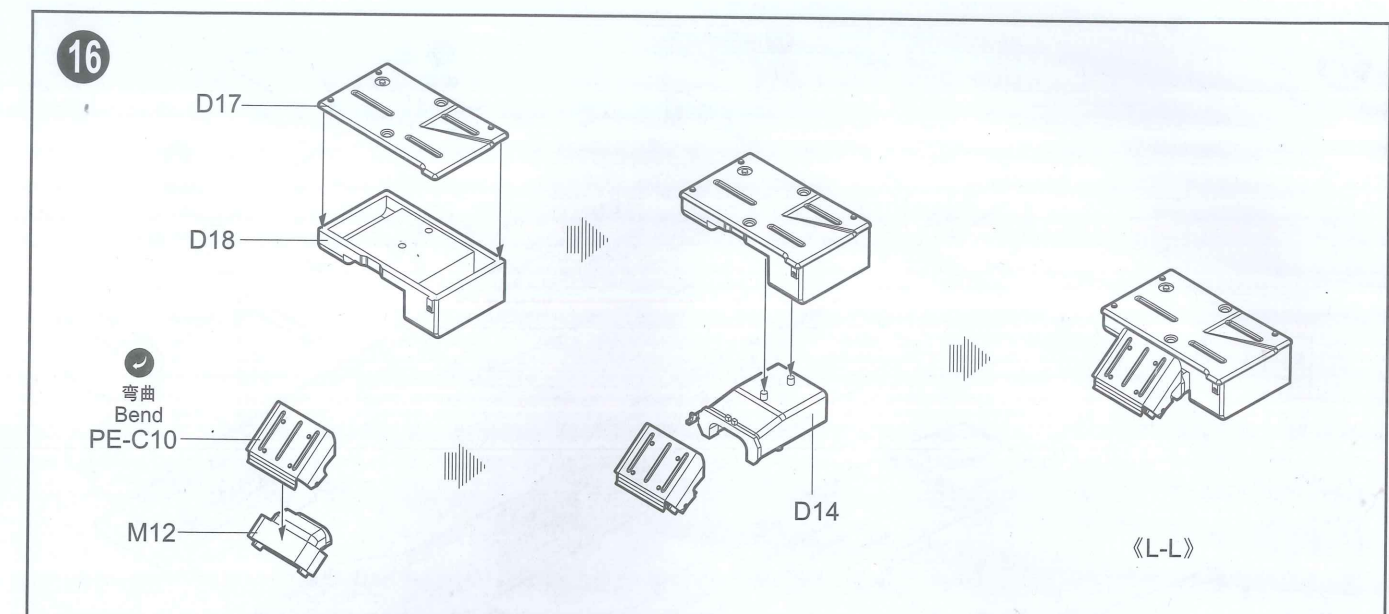

09524

13

19

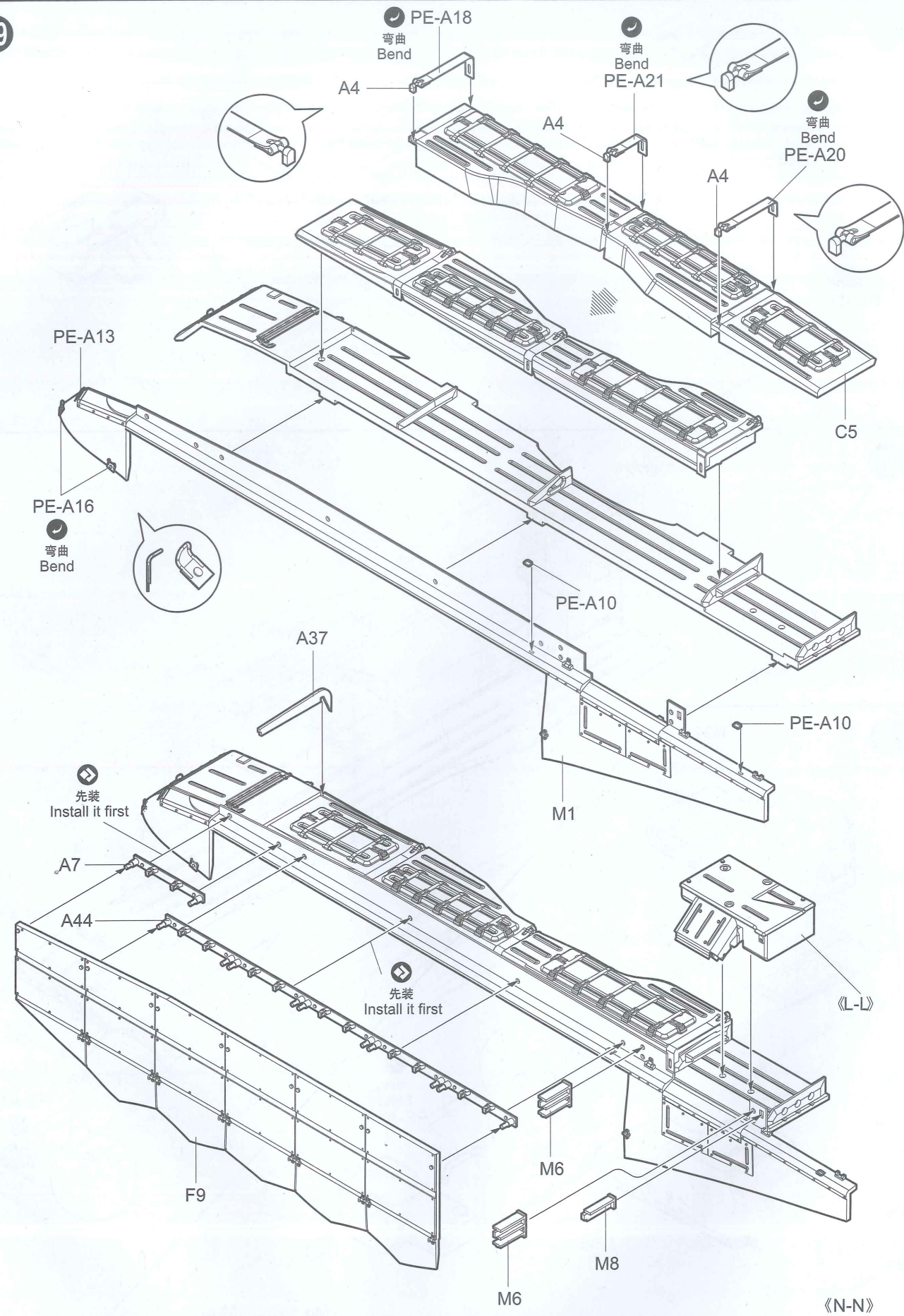

20

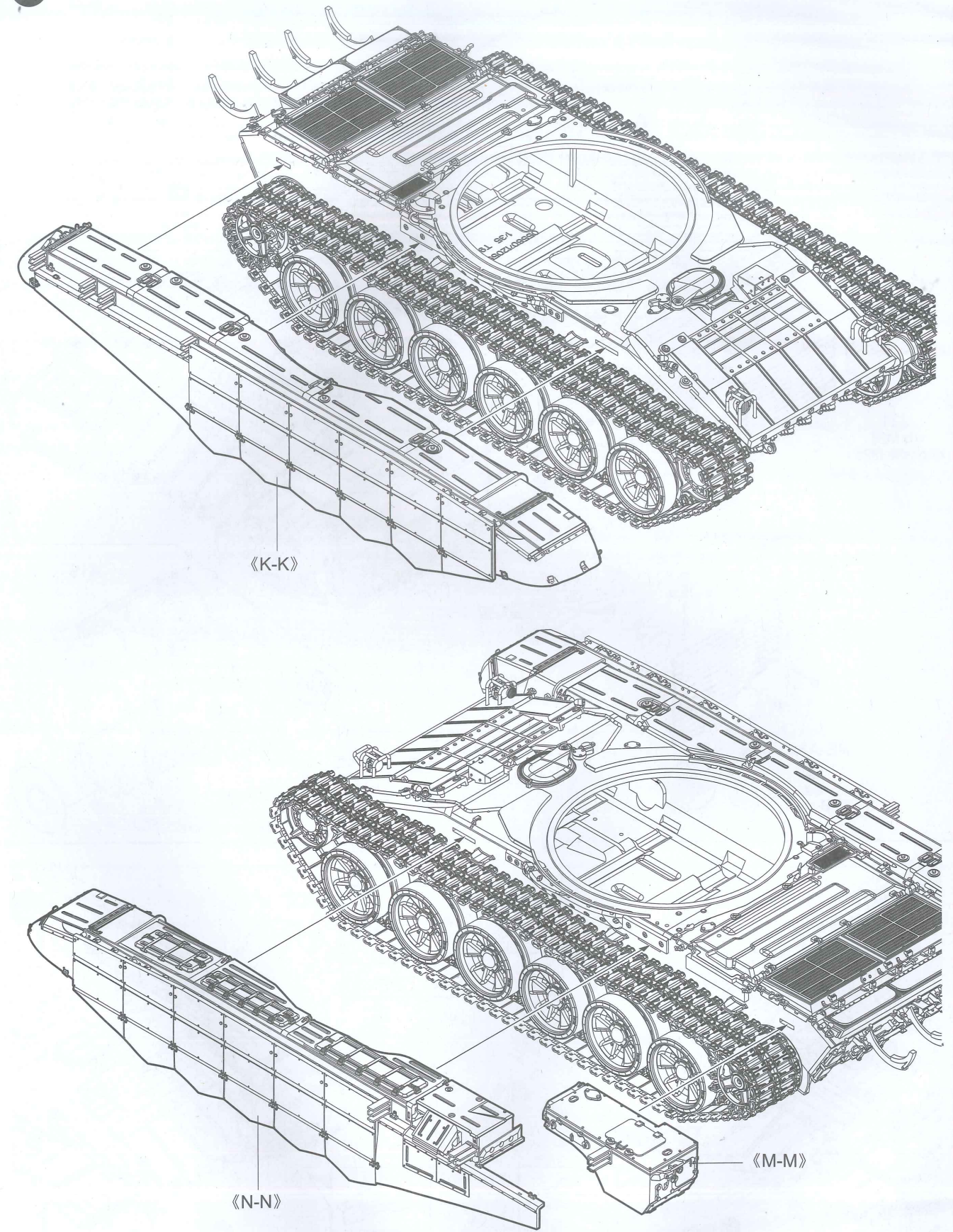

21

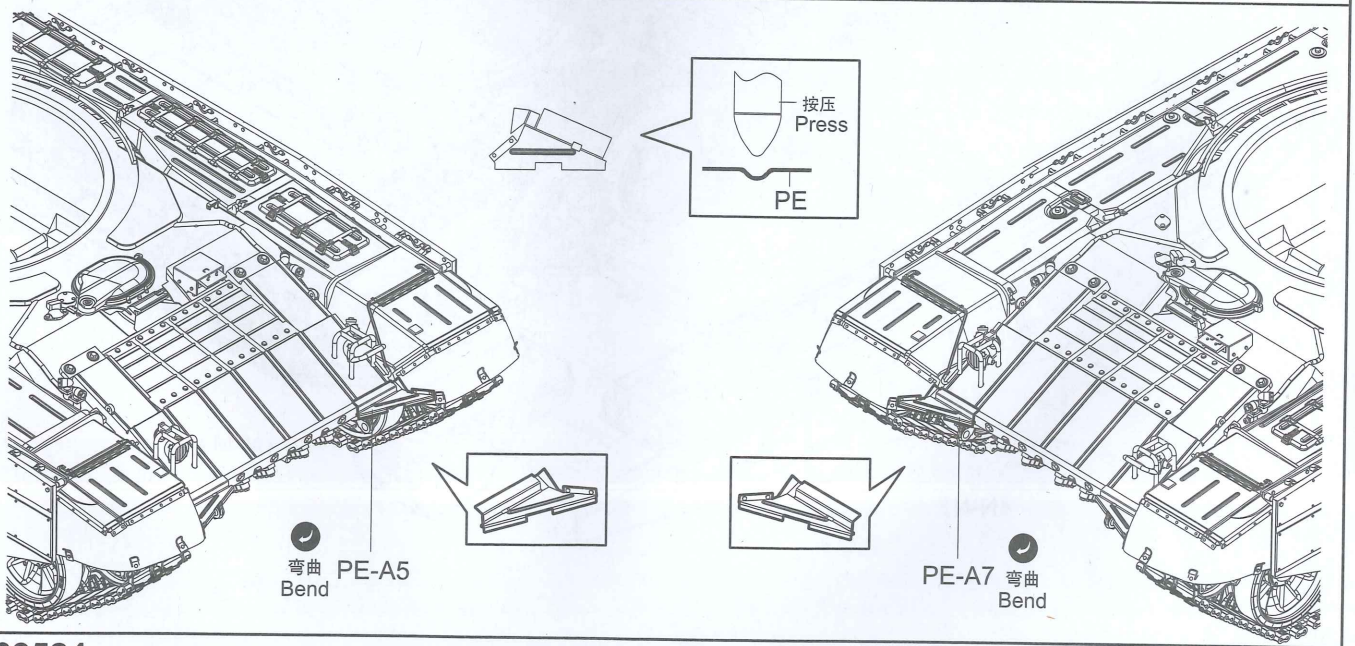
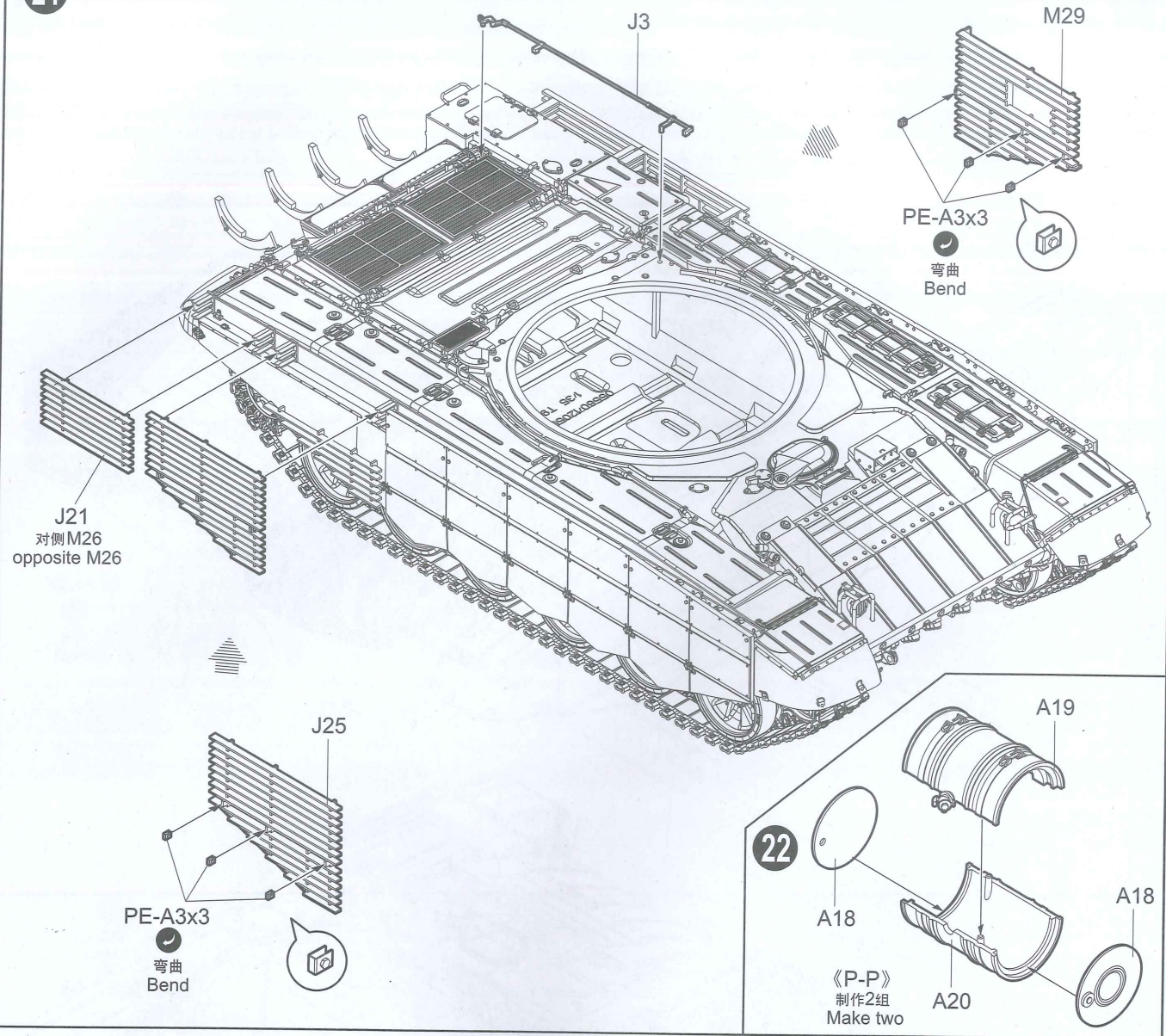

09524

16

23

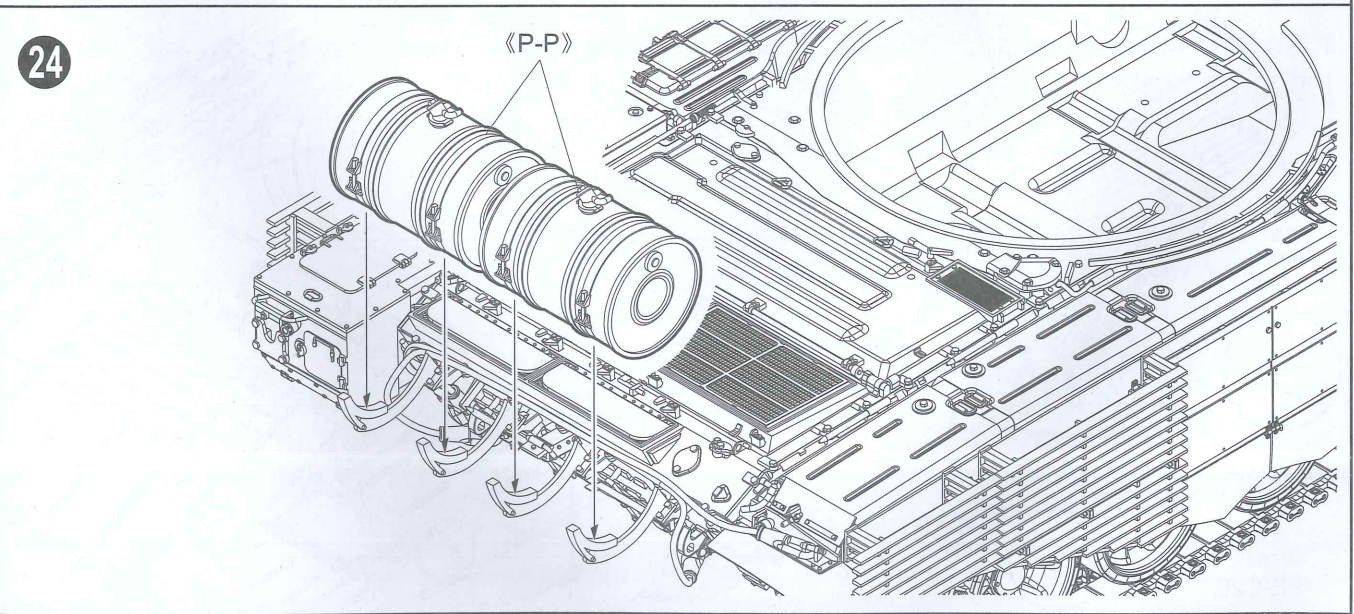
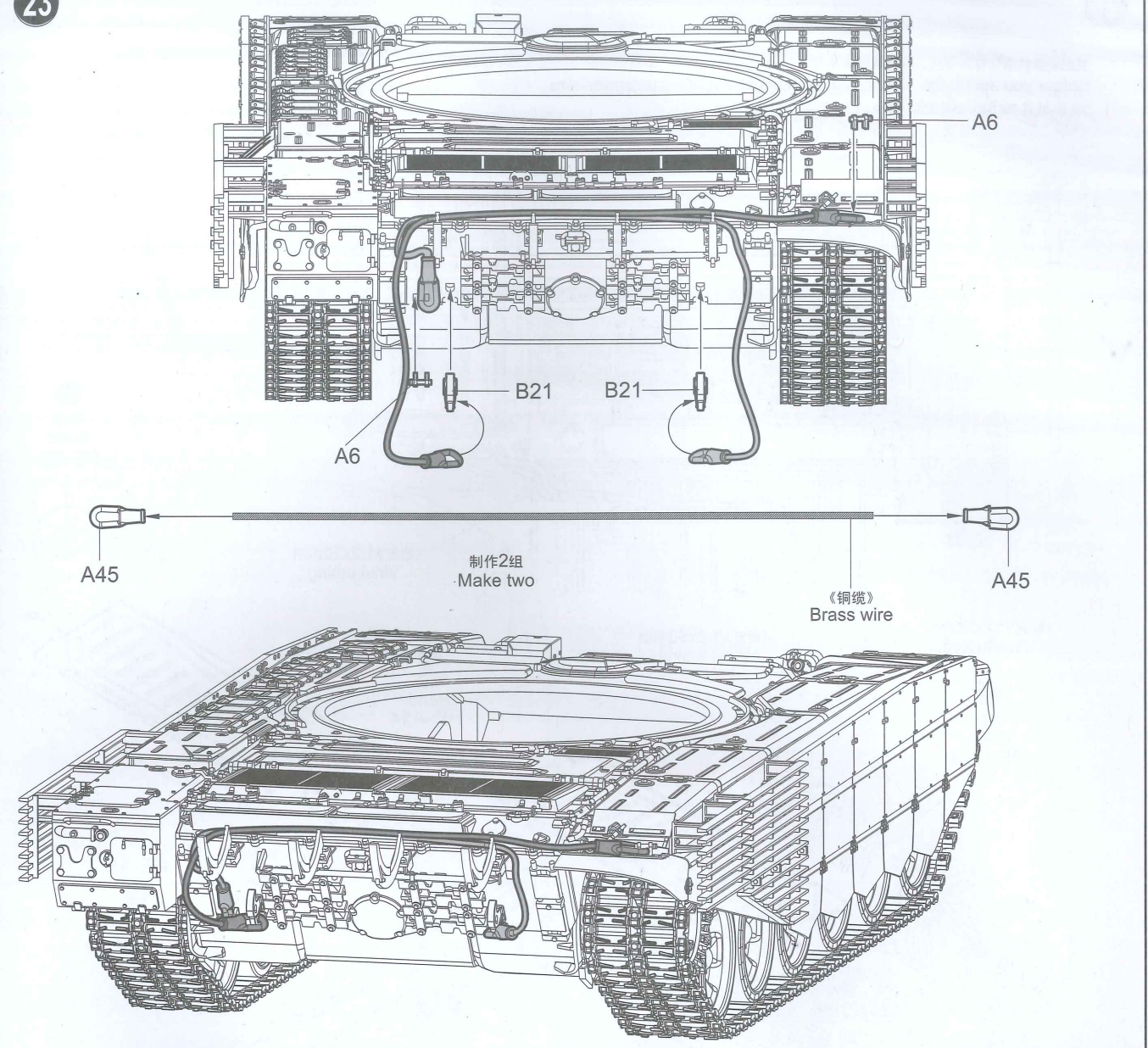

09524

17

25

装配软管前请先穿入铜丝，使之保持弯曲状态。
Before you set up the vinyl tubing, please get through the copper-wire, so that it remains bend shape.

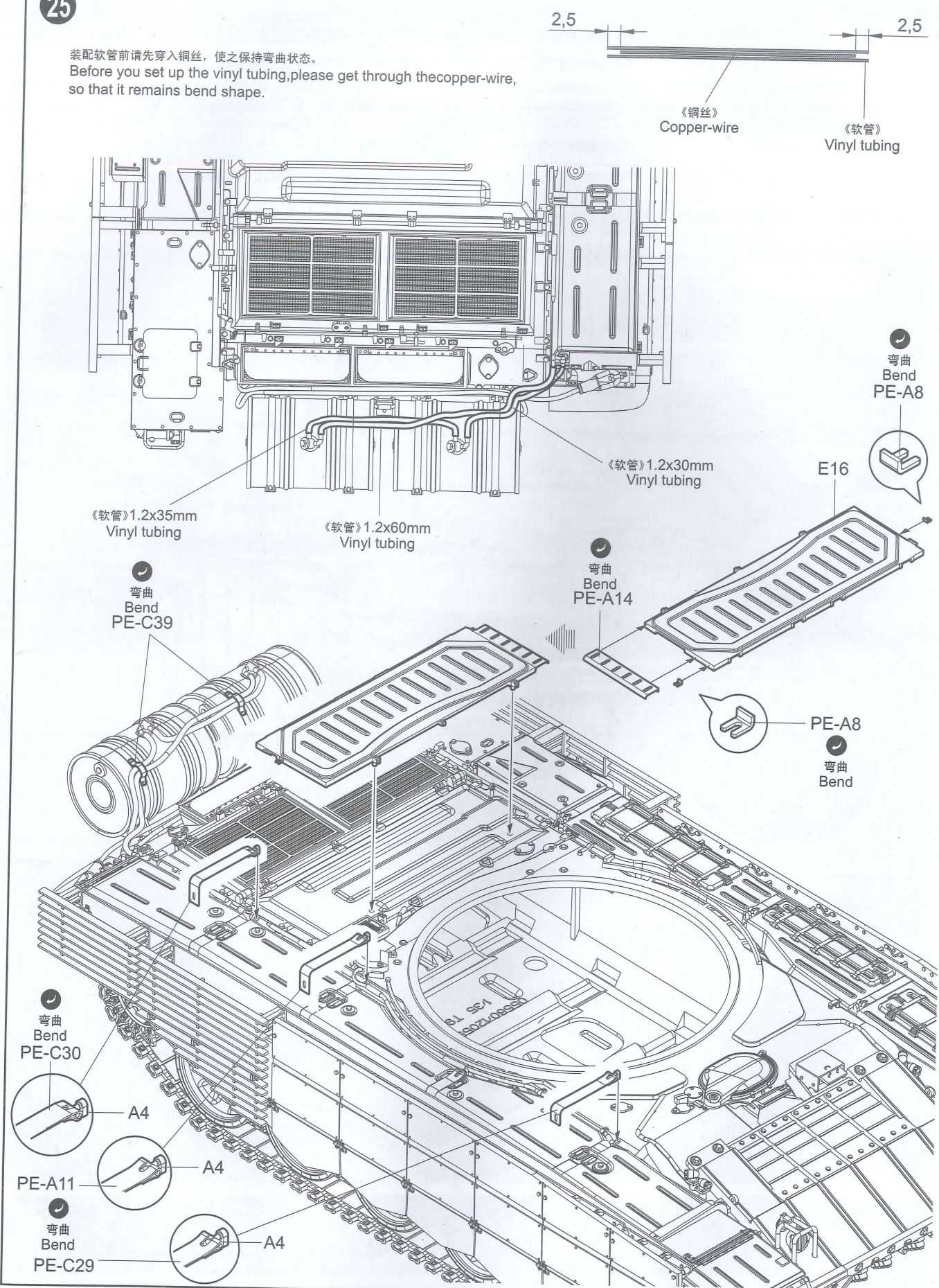

26

切除
Cut / Remove

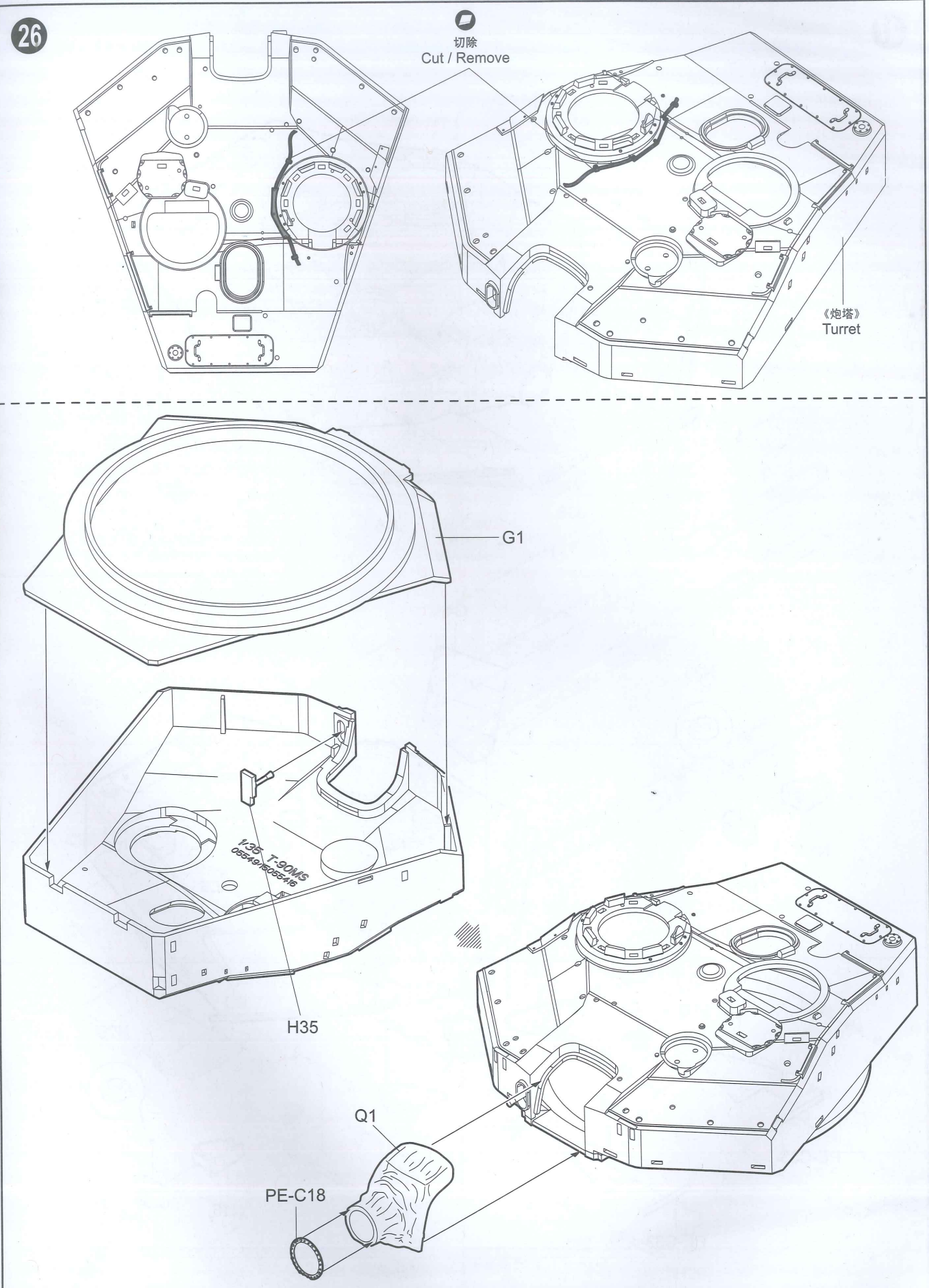

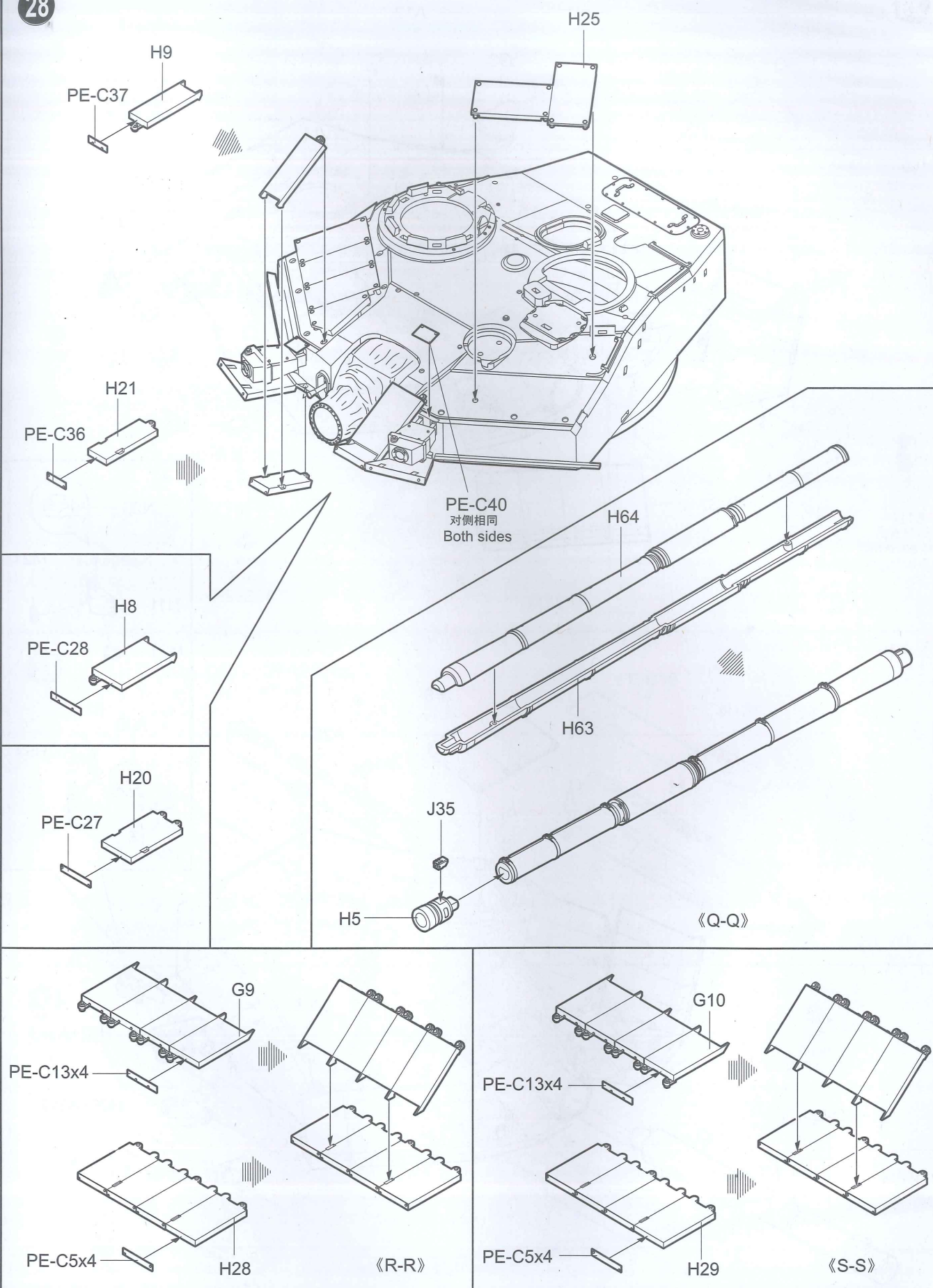
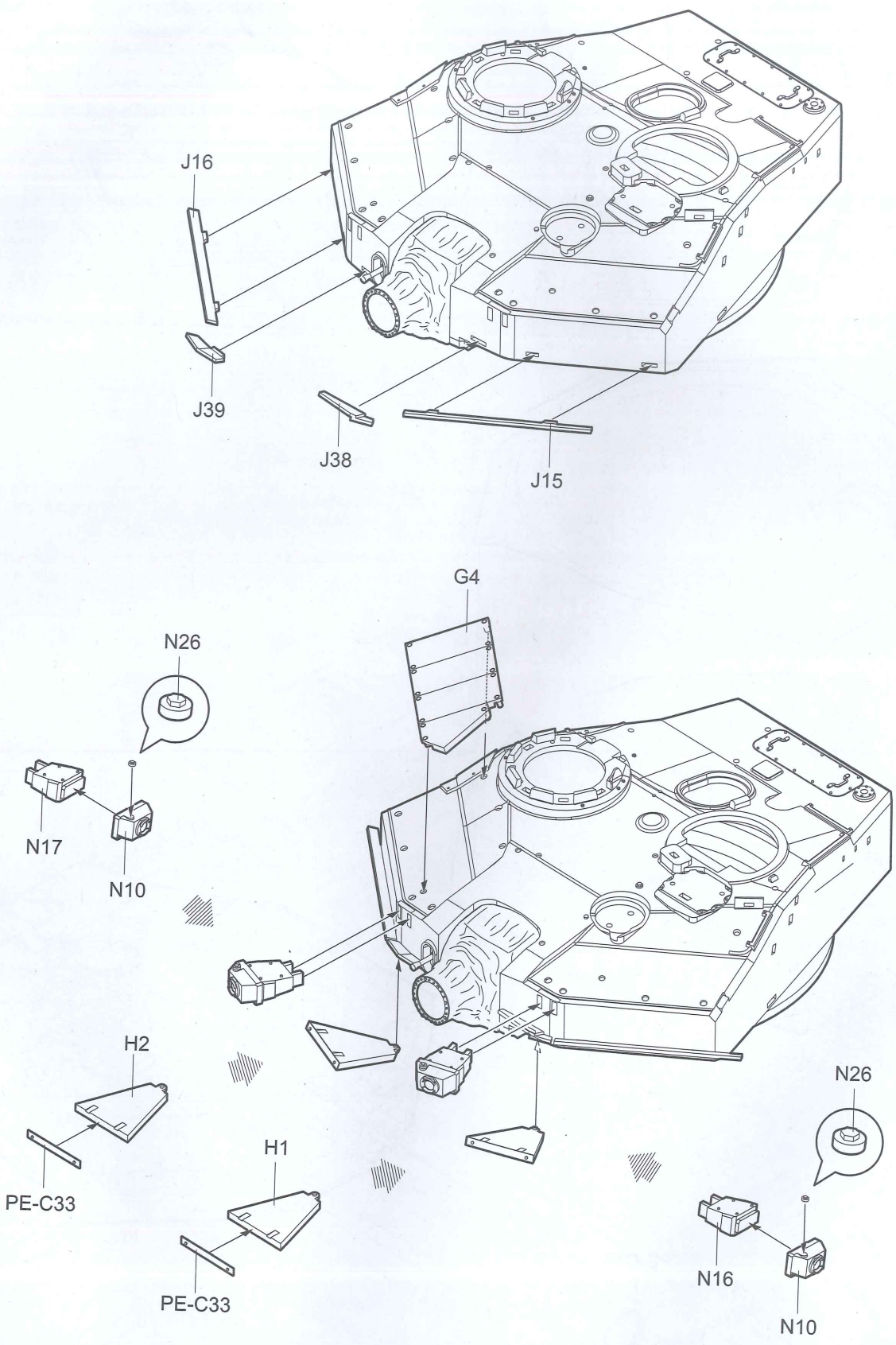

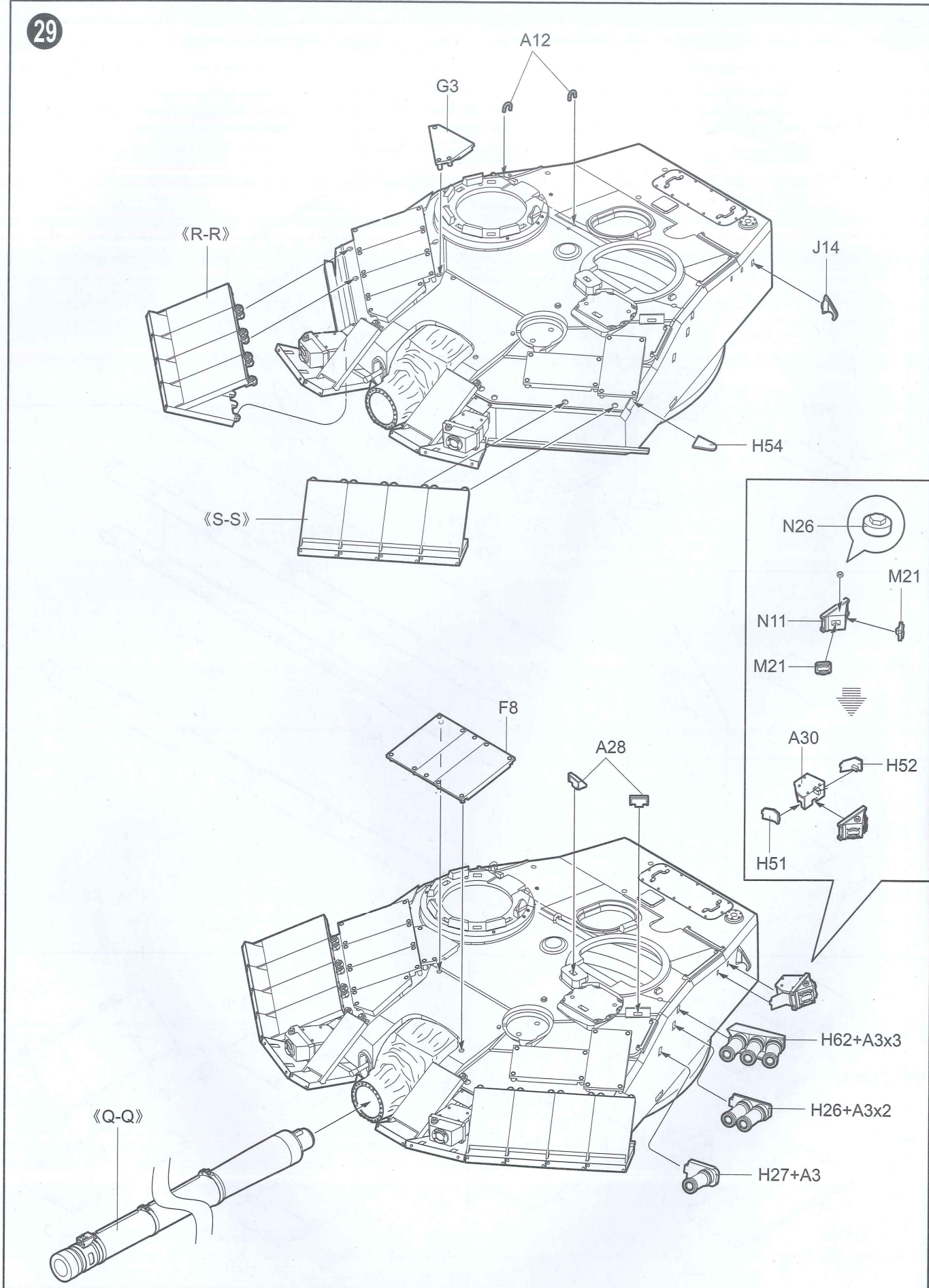

09524

22

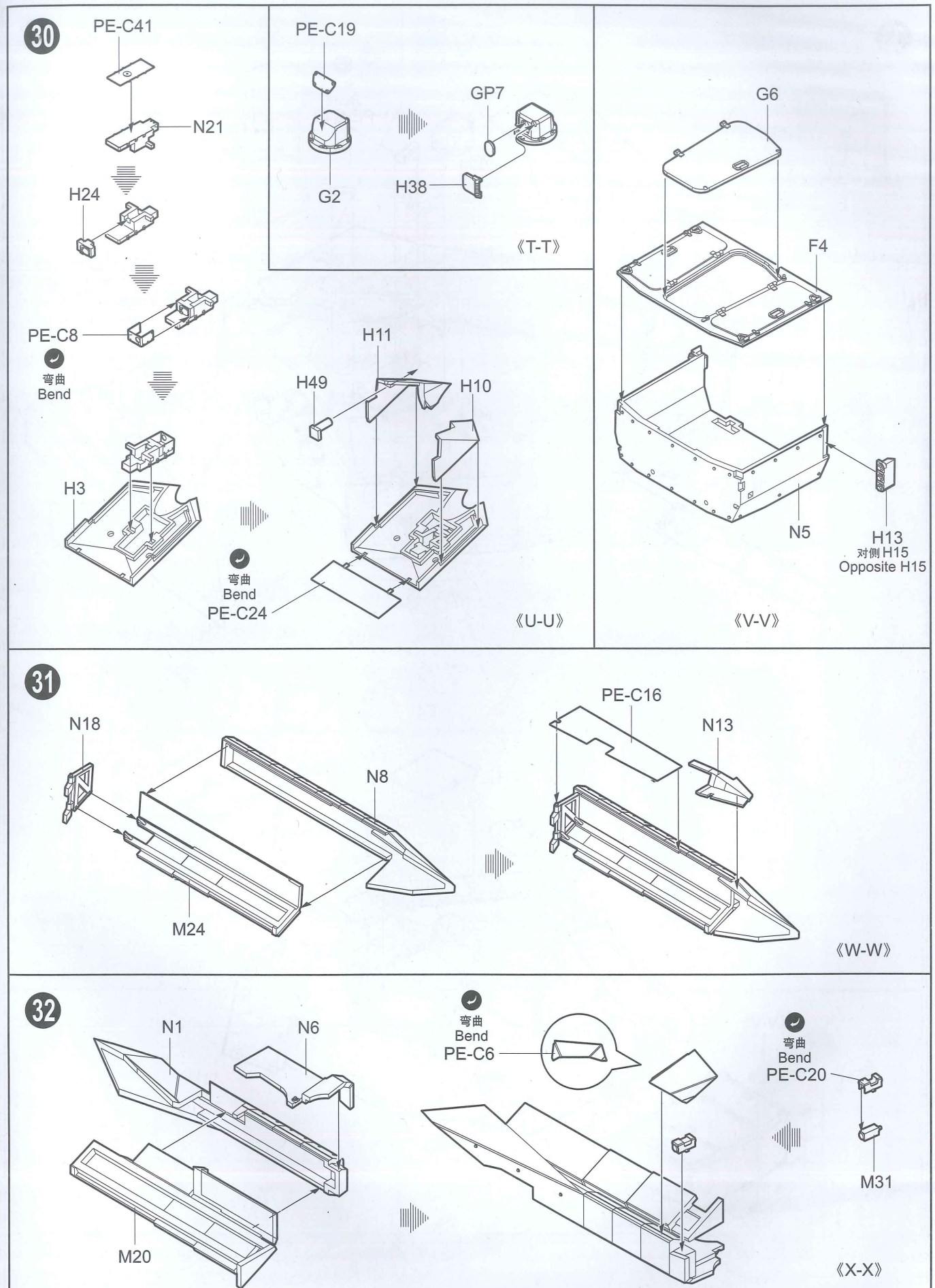

09524

23

33

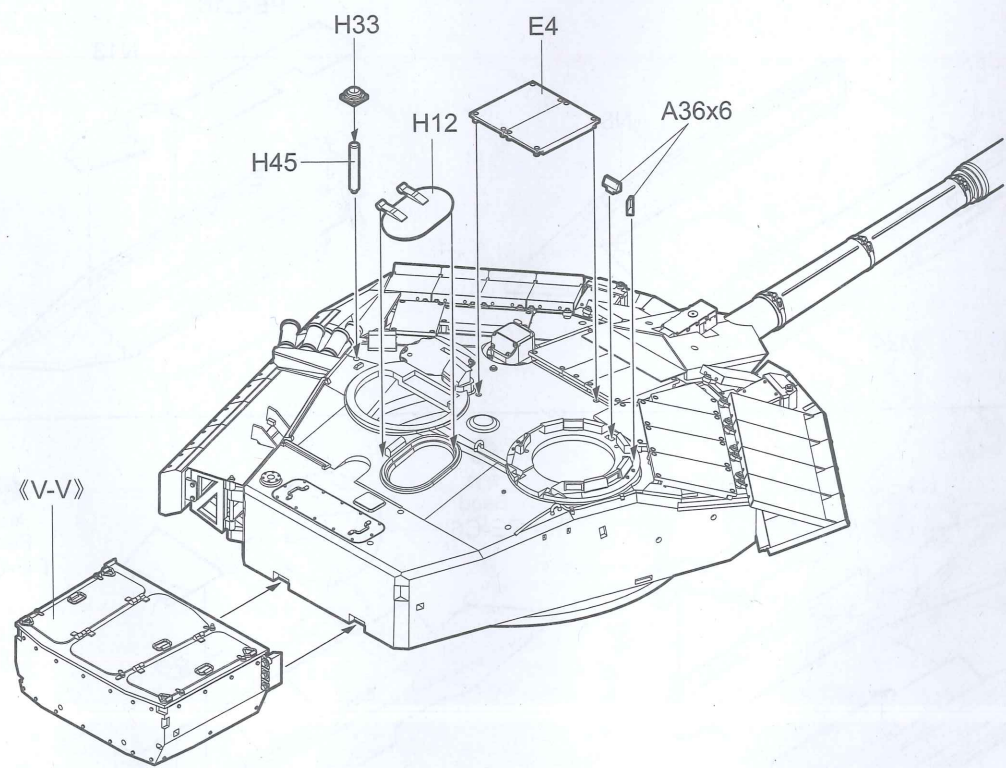
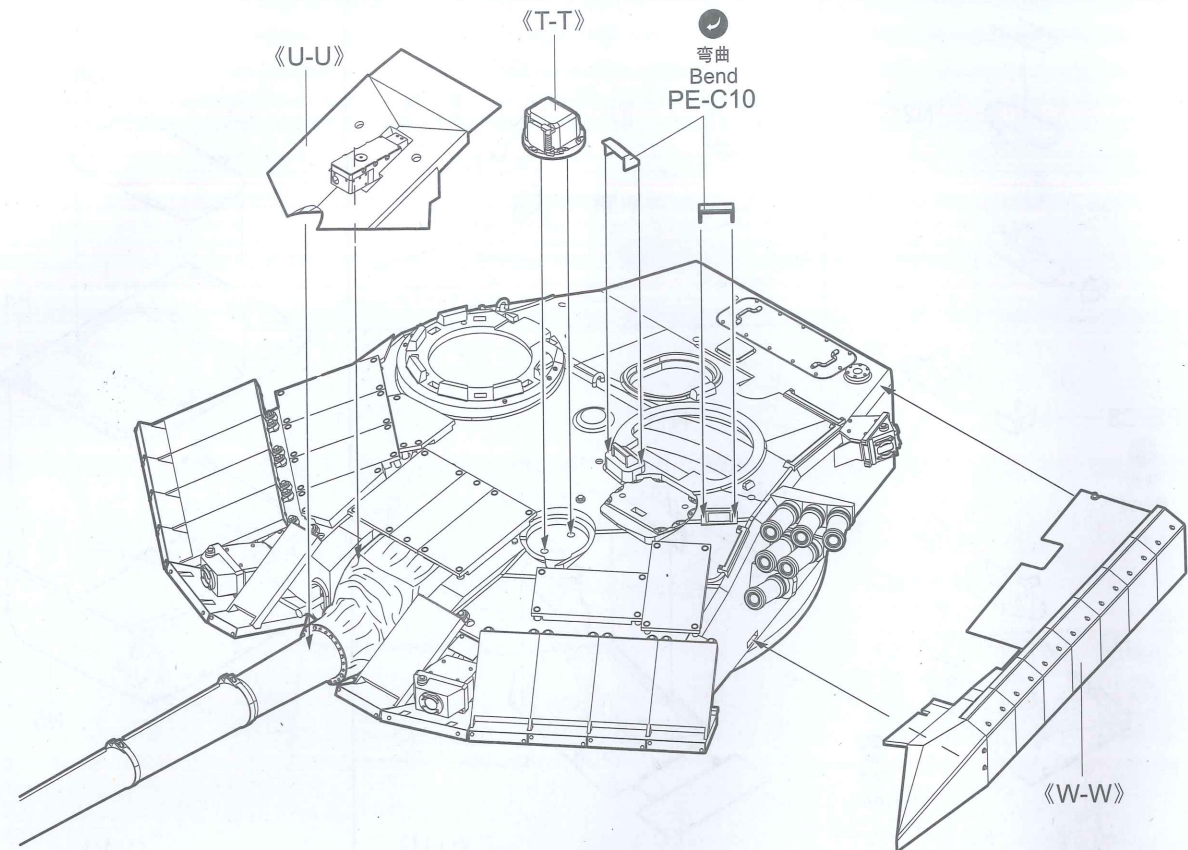

09524

24

34

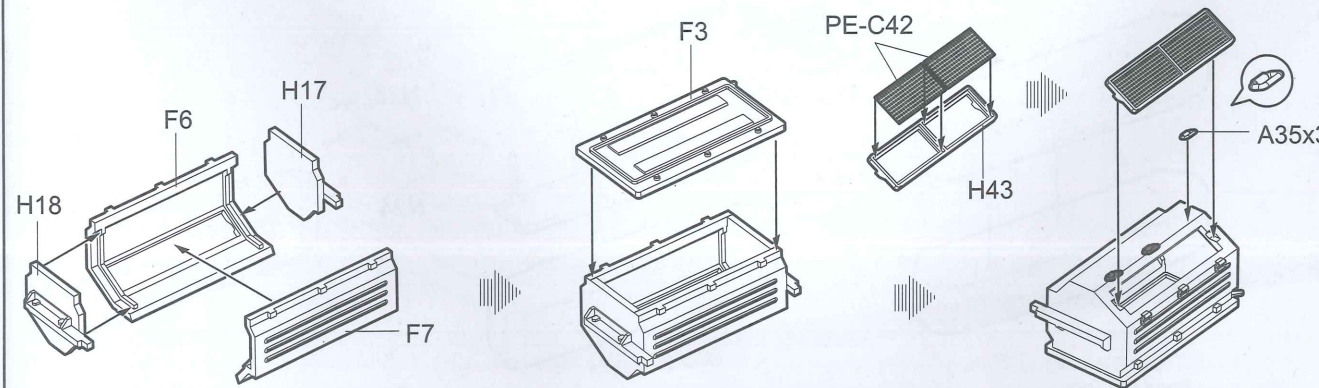
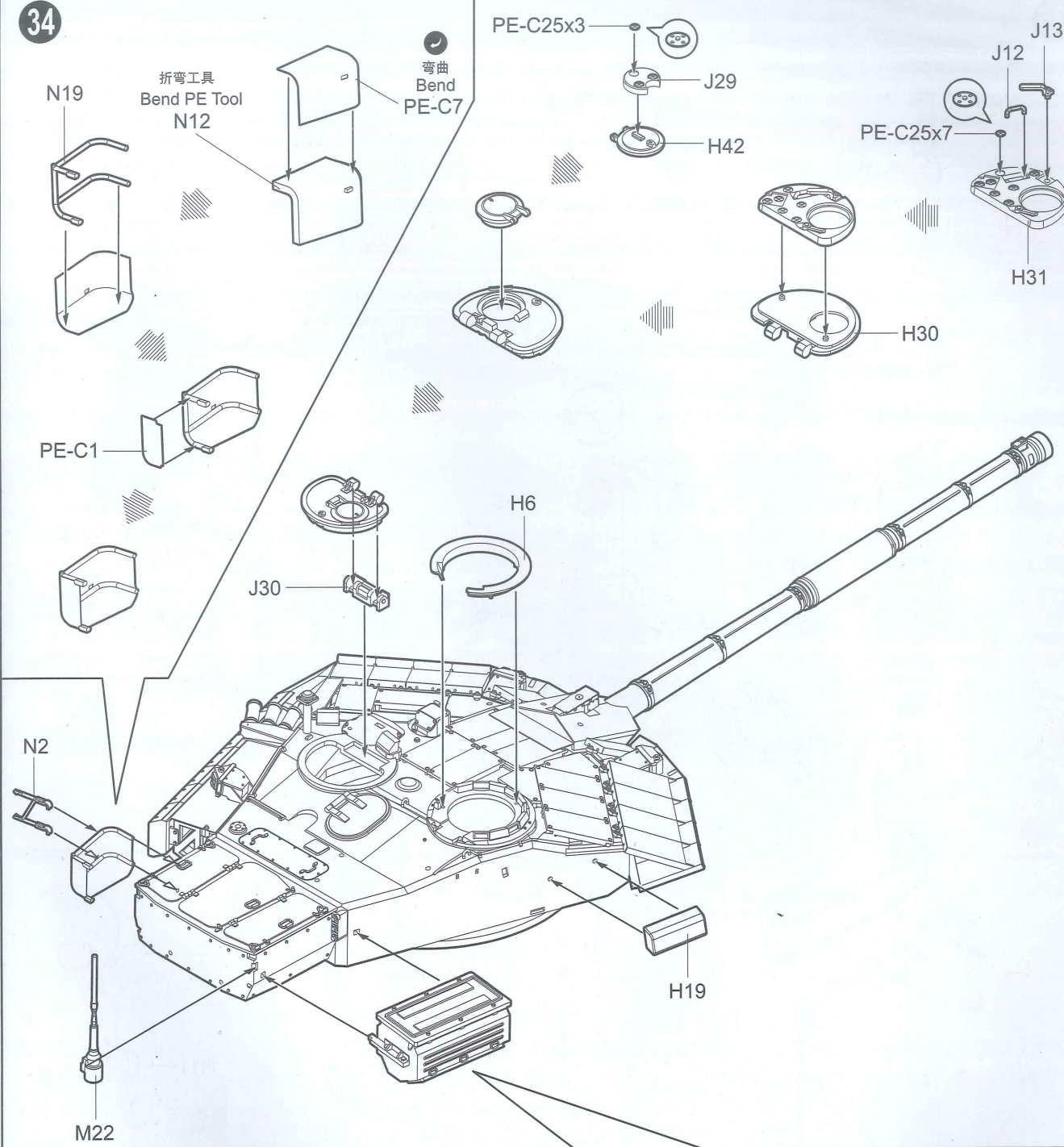

09524

25

35

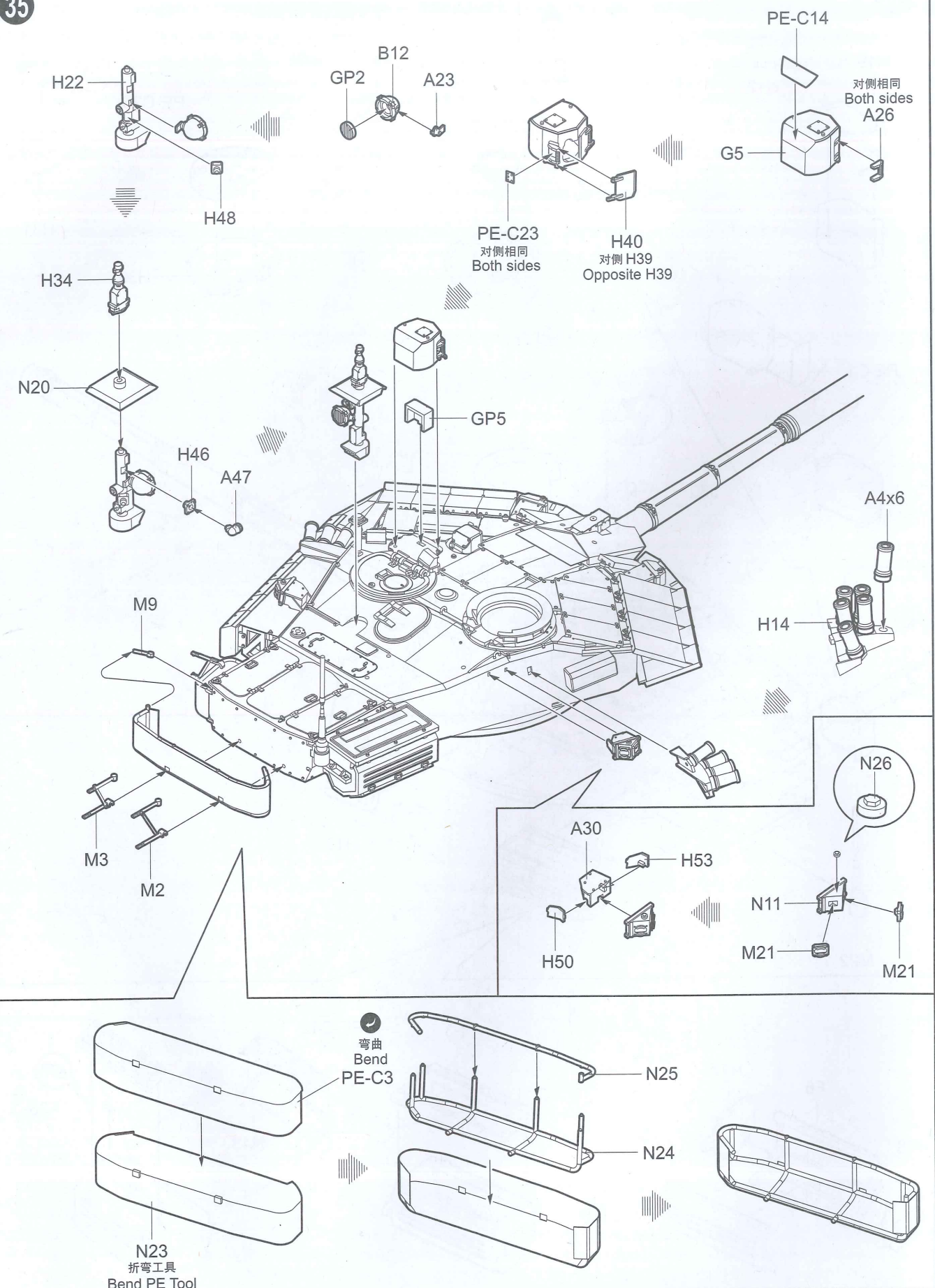

09524

26

36

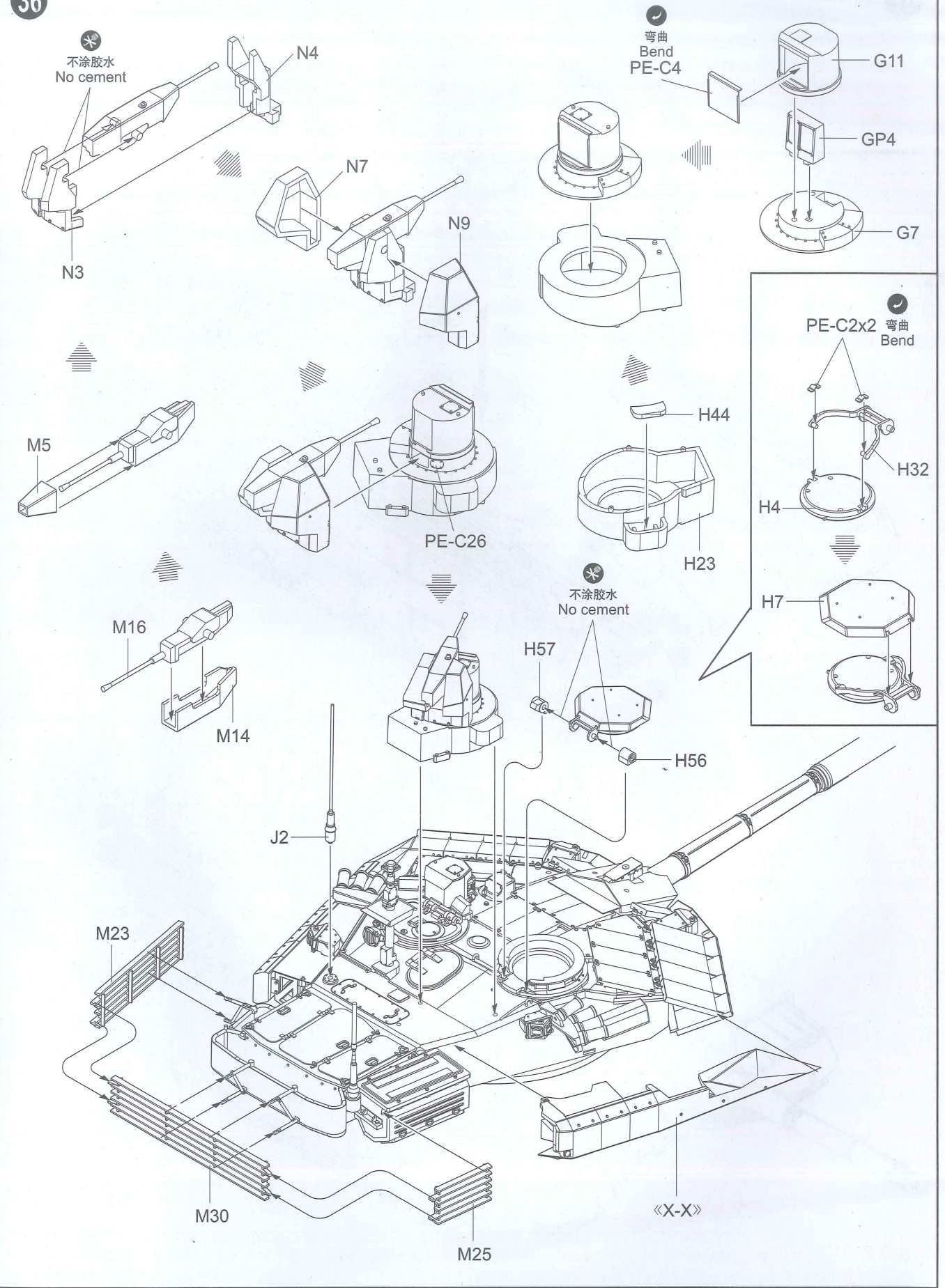

09524

27

37

