

Belcher Bits BB-37: CH-149 Cormorant 1/48

Background

The replacement of the CH-113 Labrador/Voyageur was announced in 1998, linked in with the long-running CH-124 Sea King replacement. The Westland EH-101 Merlin had been selected, but after a change of government that contract was cancelled (at a huge cost to Canadian taxpayers) and another machine eventually selected. The SAR helicopter procurement did proceed as a special variant of the transport version of the Merlin, the CH-149 Cormorant. It differs from the HC.3 version in a number of areas; no port side access door, double rescue hoist and a specialized SAR interior layout.

This conversion provides the necessary resin parts to make this somewhat complex conversion of the BIG Airfix kit as well as decals for any CH-149 in service.

Getting Started

The Parts Identifier on the previous page shows what's included. Remove the parts from their bases where required (shown as dark shading), clean up the parts and give everything a good wash with detergent to remove any release agent. Polyurethane resin requires cyanoacrylate glue to bond; it sticks VERY well, so the rule is to fit carefully before fully gluing in place. When I made the masters for the window panels, I used the port side as a guide. I found out later that the windows on the starboard side of the Airfix kit are located 0.015" higher than the other side, so you may need to do a bit of trimming and shimming. The windows in the window panel are slightly smaller than the kit windows (this is correct as these are push out exit windows) but all the windows should be centered on the same line. Don't line up top or bottom edges.

The instructions follows the kit instructions as much as possible, so Step 1 refers to the Airfix kit instruction Step 1.

Steps 1-23: As per kit

Step 24: Install blanking plate

Step 25: Modify Part A3 as shown in Figure 1 below. The 0.020" patch on the outside is a spacer between the kit inner wall and the outer fuselage. Glue this in place, let dry thoroughly then cut the window hole to match the others on that part. Chamfer the inside edges to match the other windows as much as possible. All interior surfaces are medium grey including the floor. The ramp is the same grey with a black non-skid decal.

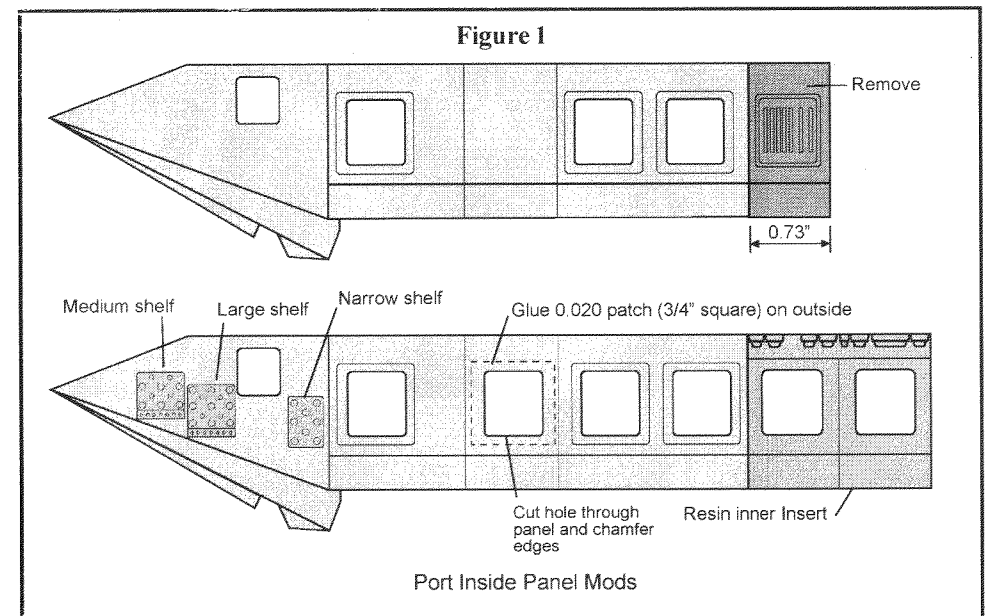
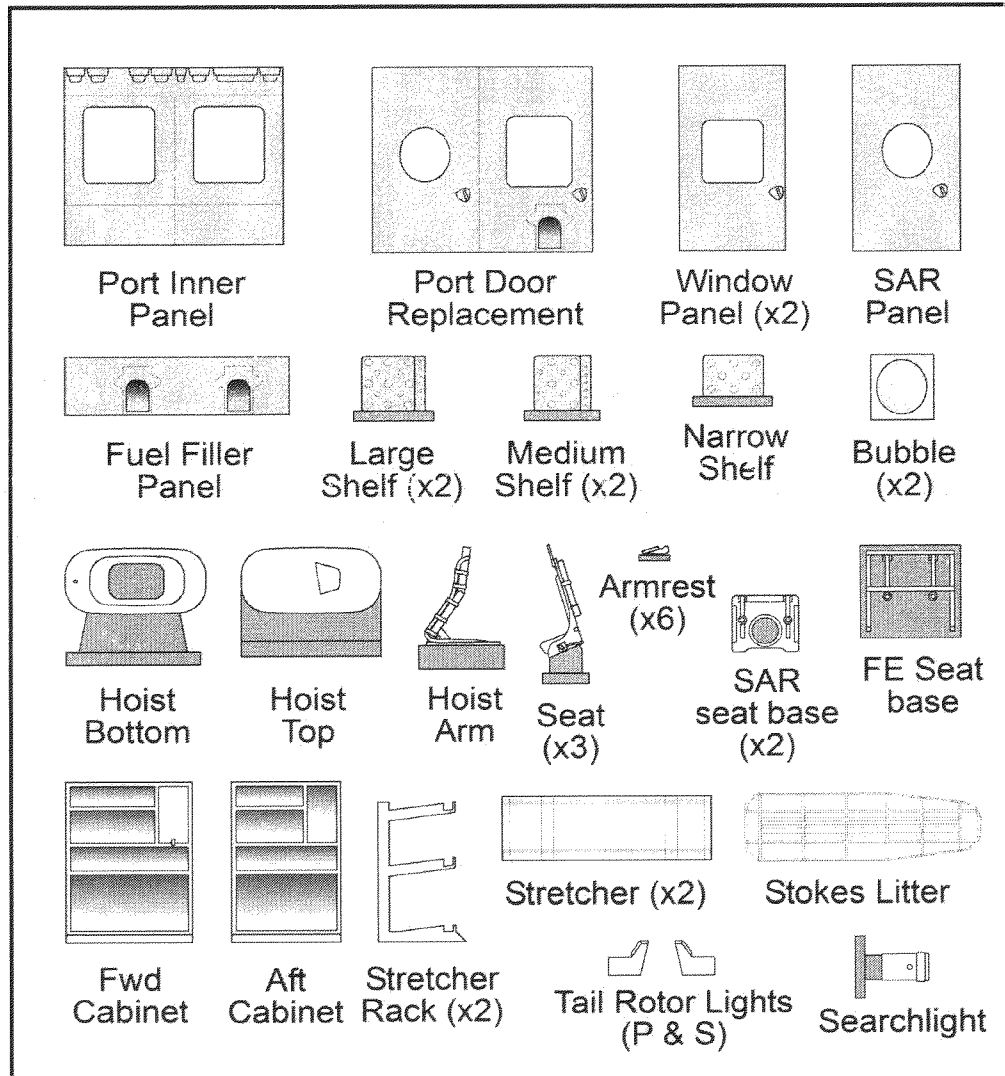

Step 26: Not required

Step 27a or b: Only 7 sling seats are used for the CH-149. Open or closed is up to you.

Step 28: See Figure 3 for seat placement.

Step 29-31: As per kit.

Step 32: Modify part A5 as shown in Figure 2, same comments as in step 25.

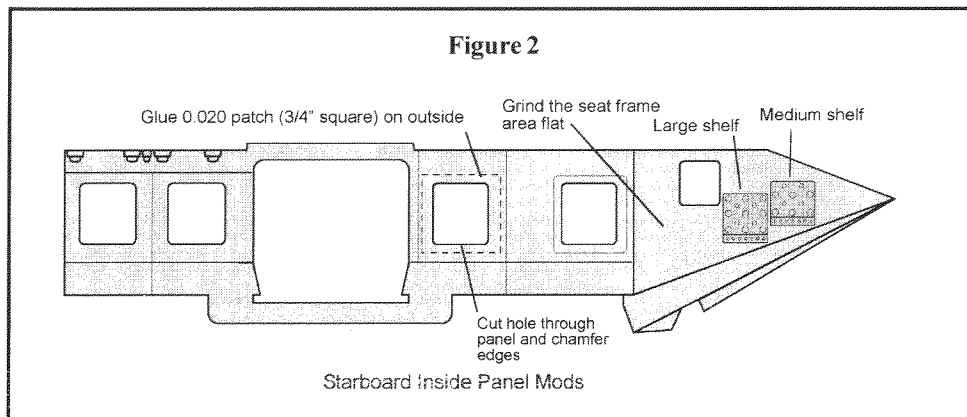

Note: This is the time to do the rest of the interior mods. Use Figure 3 as a guide.

Cabinets: Note the cabinets have a raised section on the back. Sand this off so the cabinets are 0.65" thick. Note also they are not full depth. Most photos show them stuffed full of knapsacks, packs and other unknown rescue gear. If you want to fill 'em up, go ahead. I provide them as sort of 'bas-relief' so that they give the impression of depth. The forward cabinet is wider, and yes, it really does protrude into the doorway but this is covered by the overlap of the door. That thing on the side is a cable cutter, I believe.

Stretcher racks: These are attached on the floor, and stretchers can be placed in the slots on the arms. In theory, 3 stretchers can be fitted, but usually only the top one is in place and the area underneath used to store a rescue basket (not provided) or other gear.

Remove the stretcher racks from the flash supporting them, glue in a diagonal brace of stretched sprue under each arm and glue in place on the floor.

Stretcher: I provide two. Remove from flash, sand a radiused edge on the long sides and drill 0.040" holes in the ends of each 'pole'. Insert a length of 0.040" dia rod and trim so these handles are 0.150" long. The handles are grey, the material of the stretcher is olive drab.

SAR seats: Remove the seats from the canted standoffs. Sand the flash off the seat base and open up the central hole. Drill out the two 0.040" holes in the base, noting that these are inclined backward about 8 degrees from vertical (the front of the seat base has the small cutout). Insert two lengths of 0.040" rod in the holes and trim so 0.25" extends from the seat base. These two rods sticking will sit along the rear of the seat, with

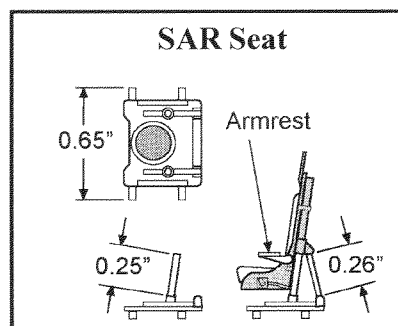

their tops just touching the bottoms of the resin rods on the back of the seat. Glue the seat in place. Glue on the armrests on the side of the seat where indicated. Next, cut a couple lengths of 0.030" rod to 0.26" long. These will serve as braces between the seat and the tabs on the seat base. Finally, cut two lengths of 0.040" square strip to 0.65" long and glue these under the base where shown.

The seat and base are black, seat cushions are dark blue-green and straps are dark grey. Armrest frames and some small fittings on the seat are a coppery metallic colour. Note one seat faces forward, the other aft.

Flight Engineer (FE) Seat: Similar in construction to the other seat, but with a different base. Sand or cut the flash away but be careful, this base is quite spindly. Same uprights and attachment to the seat, but in this case the back braces are 0.33" long and they glue between the tabs on the rear of the seat and the slots on the rear of the bars as shown. The FE seat base is already 0.65" wide so it does not need any other cross bars. Same colours as the SAR seat.

Sling Seats: Maximum seven as shown below.

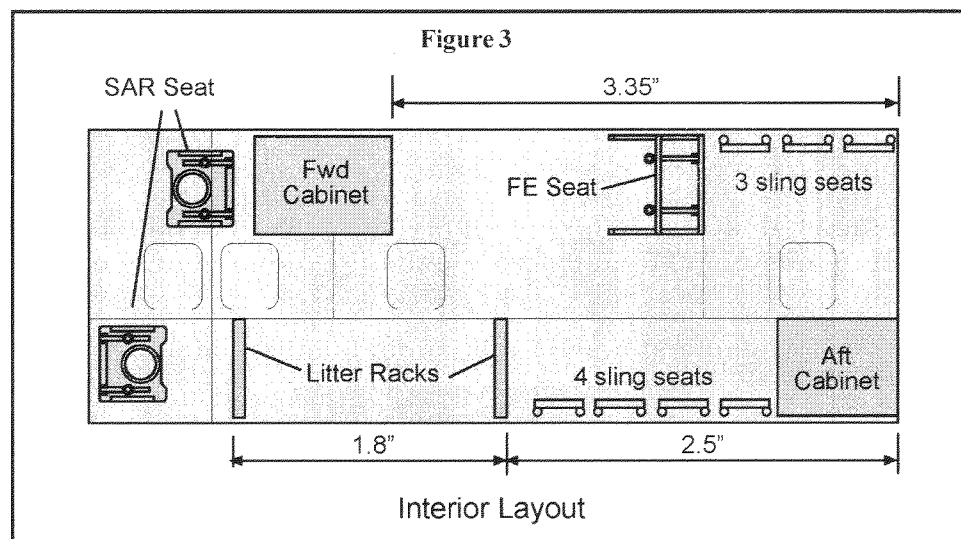
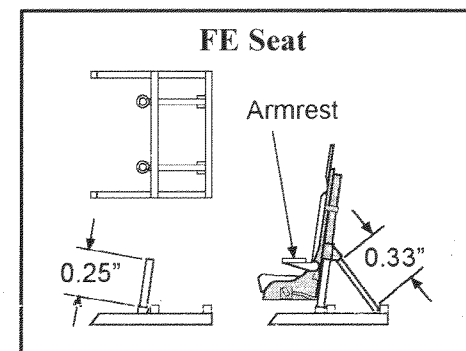

Step 33-36: Not required

Step 37: As per kit, but first paint and glue the Stokes Litter in its stowed position up against the roof, above the FE seat. I suggest painting the litter white, then drybrushing with black to suggest the netting. The bars and slats can then be painted red. Don't worry that the litter is not see-through. It is normally full of blankets, etc.

Step 38: As per kit

Note: Here is where we get into the basic exterior fuselage mods. As I said earlier, it would be a good idea to draw a line down each fuselage through the centre of the cabin

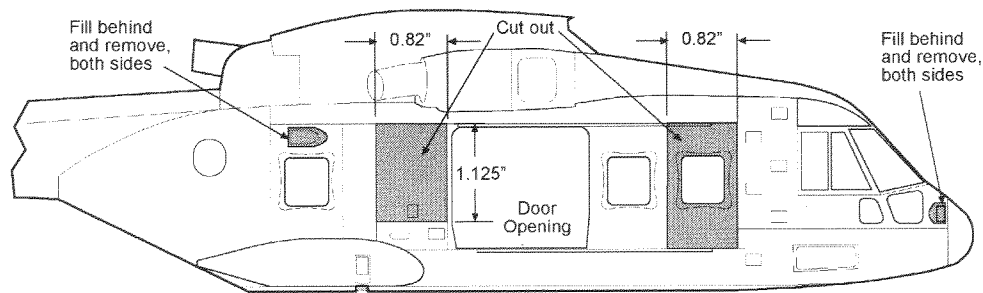

Starboard Side Cuts

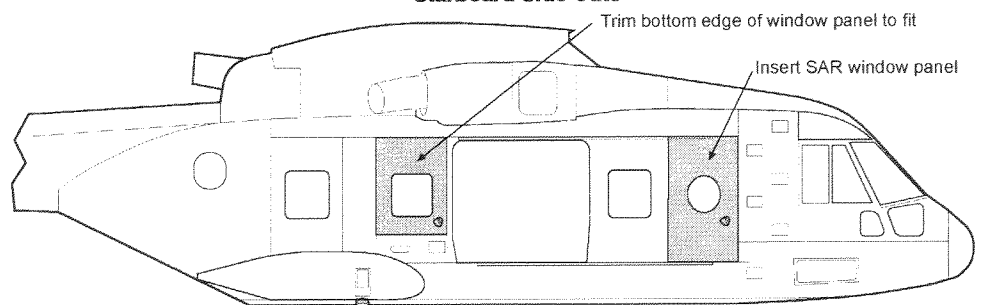

Starboard Side Inserts

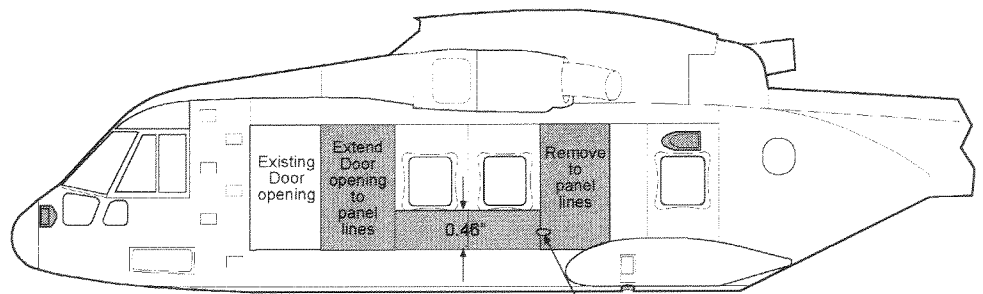

Port Side Cuts

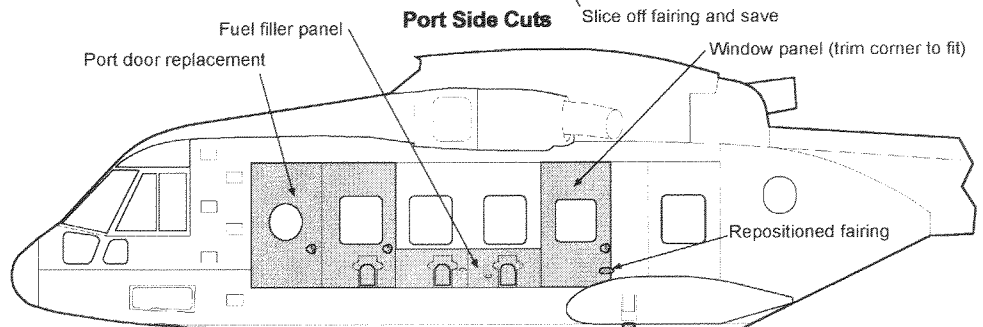

Port Side Inserts

windows. This will be used to check placement of all resin replacements. Refer to the drawing at left.

Starboard: The ECM bulges will have to go, so fill in behind with crazy glue and when dry, remove the exterior bits and fill the scar. Cut out the after panel as shown, with the aft edge along the panel line. Use the resin Windowe Panel, trim and fit. Remember that the starboard windows are a little higher on the kit, so line up along that centreline drawn to make the final fit. Remove the forward window panel completely and insert the resin SAR panel. The blob shaped scribed line around the kit windows represents a doubler plate which apparently is not on the CH-149, so fill this line on both sides.

Port: Same thing with the ECM bulges. Extend the existing door cutout to the next panel line back and square the corners. Remove the bottom section under the next two window panels. I note on the drawing to try to recycle that large fairing on the aft end of this panel. If you can't it's easy to scratch up a replacement. Remove the next panel completely, although you can just cut down to the groove for the sponson. Insert the resin Port Door replacement, Fuel Filler panel and trimmed Window Panel, remembering to keep the centres of the windows in line.

Windows: The clear parts are put in from behind on the kit so this is the time to address these. Follow the kit instructions, where applicable. The leftover E5 window from the forward starboard side can be used for the extra window on the port side, but you will need to trim off the flange. The two bubbles at the SAR stations are provided in clear vacuform. These are designed to fit from behind, so simply trim these with a small flange around the exterior and glue in place. The two slightly smaller windows for the resin window panel need to be cut from the PETG sheet supplied. Use the clear kit parts E7 for the after cheek windows, but the port side one will need to be slightly modified later for the ice accretion sensors.

Steps 39-70: As per kit

Steps 71 and 72: Use the B62 and B63 parts with the flotation bags

Steps 73 and 74: No ECM are fitted to the CH-149, so parts C59 are not required. Use plastic card or modified parts C4 and C5 to fill in the cutout on sponson bottoms.

Steps 75-78: As per kit.

Steps 79-81: Do not use and fill the depressions for the ECM pods in step 81.

Steps 82-87: As per kit

Steps 88-91: Do not use.

Step 92: Use the blanking plate, fill seams and sand the nose cone smooth.

Steps 93 and 94: Use the air bags (parts D22 and D24)

Steps 95-98: As per kit.

Step 99: Fill the hoist hole in the lower fuselage and do not use part D19.

Step 100: Parts C13 not required.

Steps 101-102: Do not use parts C14. Fill the mounting areas for these.

Steps 103-105: As per kit.

Steps 106-120: Do not use.

Steps 121-124: As per kit

Steps 125: Do not use

Steps 126-138: As per kit

Finishing Touches

Hoist: Trim resin Hoist Top and Bottom and glue together. The flat face of the fairing on the top part faces aft, and the dot on the mating surface of the bottom indicates the forward end. Fill the seam, paint gloss red and put aside for later final assembly. Cut the casting plug off the bottom the resin Hoist Arm and sand the top edge of the mounting plate down until the plate is 0.187" wide (a slight oopsy on my part). Sand the area above the starboard door smooth, and attach the hoist arm just above the door track, with the front edge of the plate 0.39" forward of the rear edge of the doorway. There is a small triangular tab on the curve of the mounting arm and you need to cut a short length of 0.030" rod to fit between this tab and little plate just aft of the doorway about 0.90" above the bottom. When painting the aircraft, the arm and bracing rod are yellow, and the cables looping up the arm are black held in place with metallic bands. In final assembly, the arm attaches to the hoist itself by gluing onto the back of the fairing on top of the hoist.

Tail Rotor Lighting: A unique feature to CH-149s, these small lights illuminate the tail rotor when the pilot is operating in tight situations. At the rear tip of the main fuselage just at the end of the ramp area are two flat areas. The resin parts glue into these areas. The inner section faces slightly upwards while the outer faces straight back. See the photo for more information.

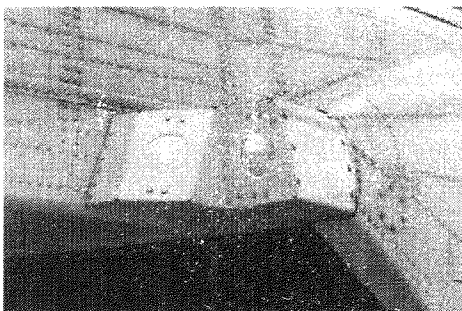

Ice Accretion Sensors: These are fitted on a small plate on the top corner of the port-side foot window. Too tiny to make in resin, you are on your own here. If desired, these can be made up from some plastic strip and some thin brass wire, maybe with a drop of white glue on the ends. The small box and two sensors are black. See the photo.

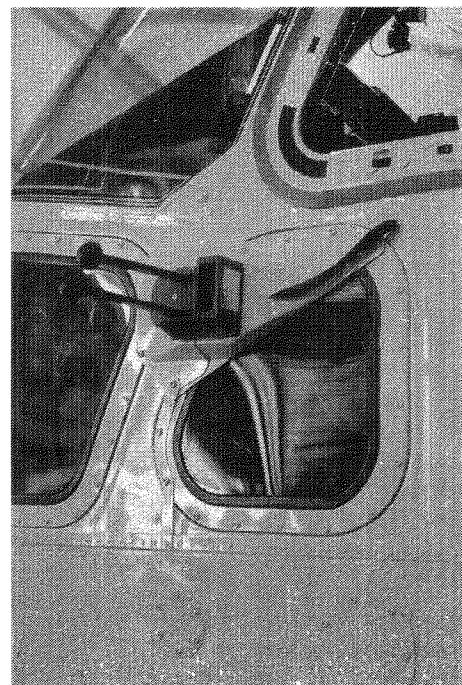

Nite Sun Searchlight: I provide the basic searchlight but mounting will have to be by the builder. Under the forward fuelling port on the port side are four small tabs, 0.82" apart. On the Merlin, these are weapons pylon mounts but on the Cormorant, these are where the searchlight frame attaches. Sand the little rectangular points down a bit and drill a 0.020" hole at each location. Bend some brass wire in a broad V so that the point of the V is 0.25" out from the fuselage, and the ends of the V turn sharply and into the lower holes in the fuselage. This frame is horizontal. Do the same thing but the arms of the V should be slightly longer and the point

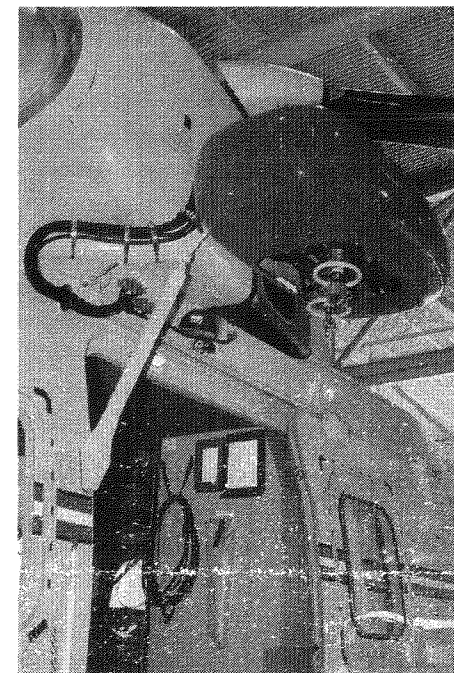
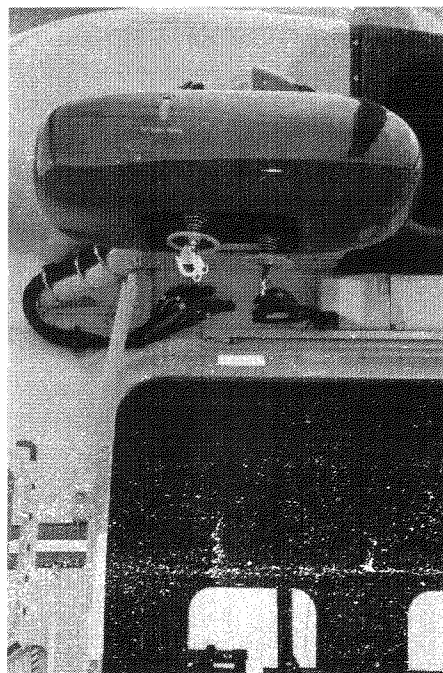

have a small straight section. This V goes from the top set of holes and is joined to the other V at the point of the V. Make a small 0.080" disk of plastic approx 0.040" thick and glue it under the joint of the two frames. Take a piece of thin brass strip 0.040" wide and bend into a U, approx 0.24" wide and deep. Glue the top of this to the bottom of the disk. Remove the resin searchlight from its casting plug, and glue it into the U at the two small protrusions on the side. For more accuracy, you can punch out a 0.10" disk of 0.020" plastic and glue it on the back end of the searchlight. Wiring runs from the top of the searchlight, looping forward and then through the mounting frame and under the fuselage. It sounds like a lot of work, and it can be fiddly so it's best left until the end of the build. The frame is yellow, and the searchlight is black. The reflector of the searchlight is bright metal, and you can punch out a thin disc of clear plastic for the lense, or use Crystal Clear.

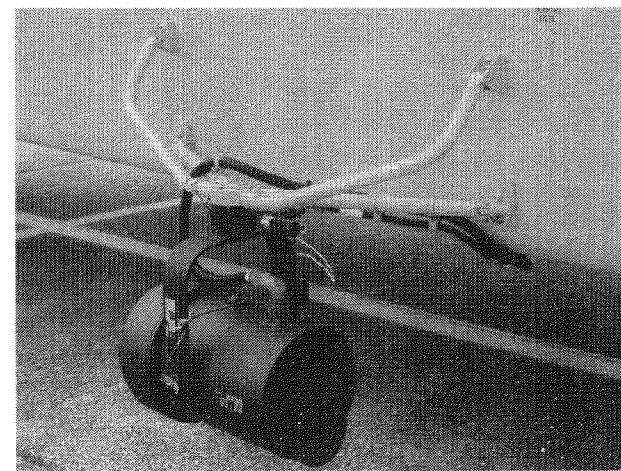

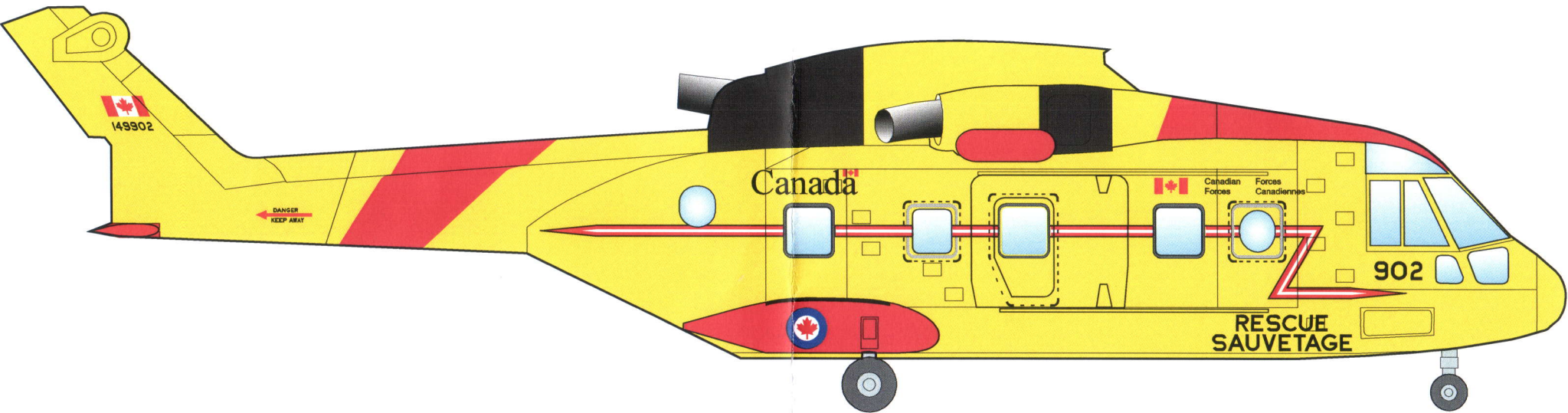

Canadian Forces Forces Canadiennes 149901 BD27a: CH149

Canada

Canada

149901

Canadian Forces Forces Canadiennes 2 3 4 5 6 7 8 2 3 4 5 6 7 8

SAR windows

Exit windows

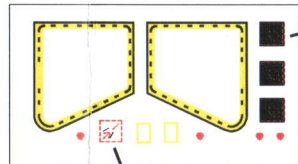

Use on yellow

Use on black background

RESCUE SAUVETAGE
 RESCUE SAUVETAGE
 23456780
 23456780
 RESCUE 901
 SAUVETAGE

Ramp decal

Under fuselage

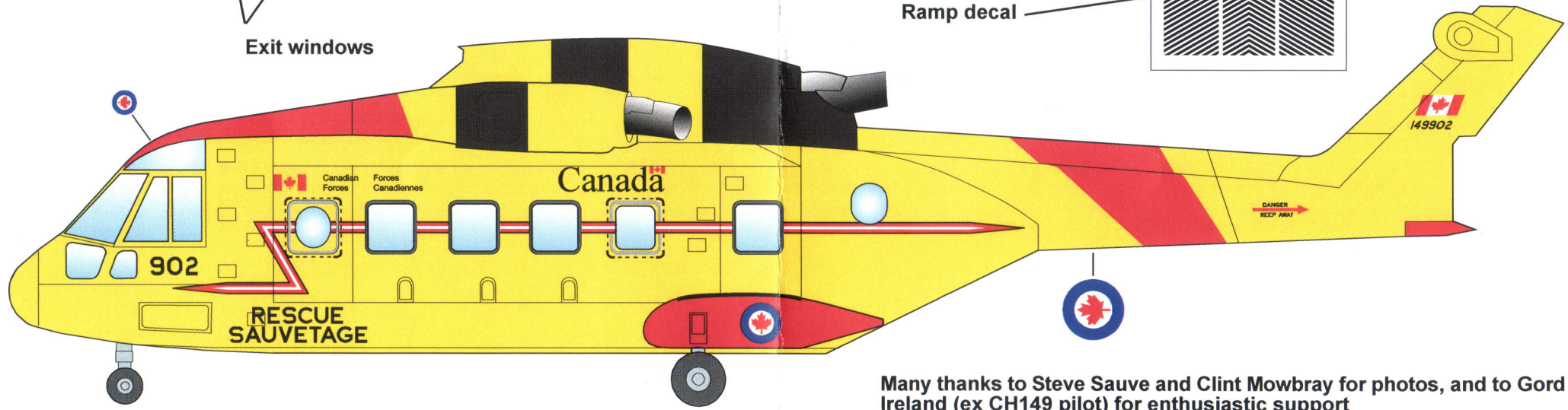

Many thanks to Steve Sauve and Clint Mowbray for photos, and to Gord Ireland (ex CH149 pilot) for enthusiastic support

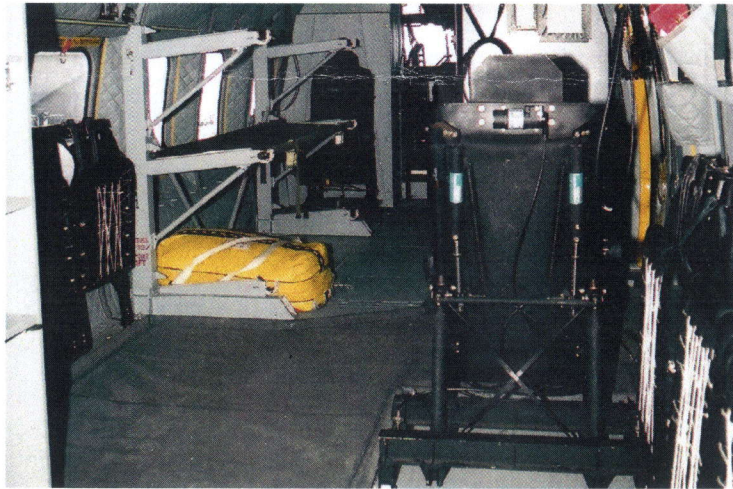
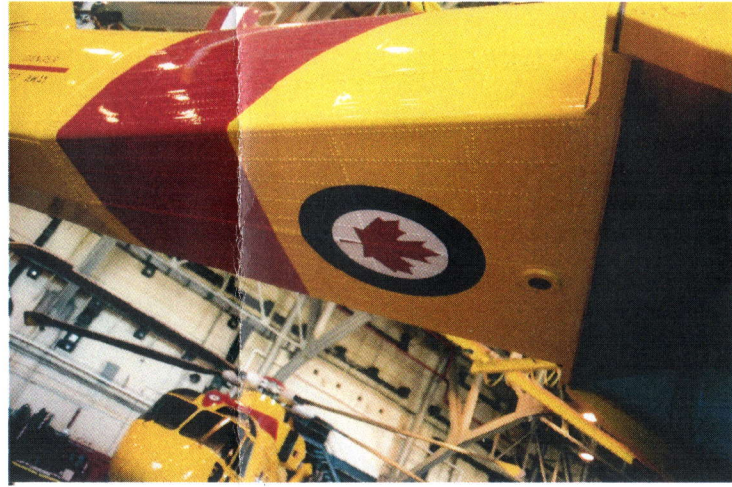
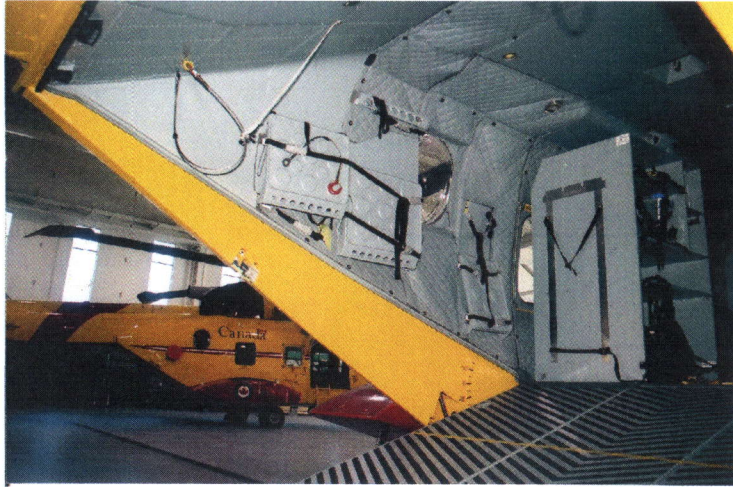

Clockwise from left: Window detail, Cabin looking forward (note the cross bracing on the back of the seat and the diagonal bracing on the stretcher racks), Port rear cabin (note shelves folded up), Under tailboom (showing location of large roundel), Nose detail (showing location of small roundel on fairing above cockpit), SAR seat.

Above: Exhaust markings on rear pylon. Note the red warning on the yellow background (only on this side) and the yellow and red warnings on the black painted areas. Also note the yellow rectangle marking a step on the black area.

