

1

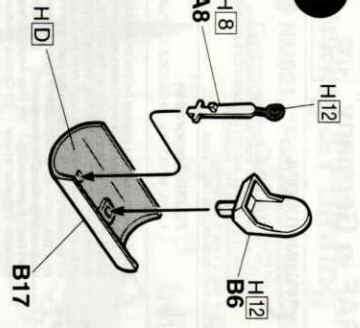

2

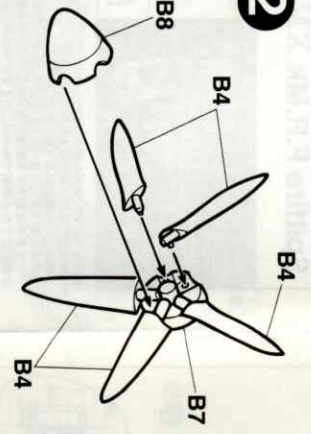

5

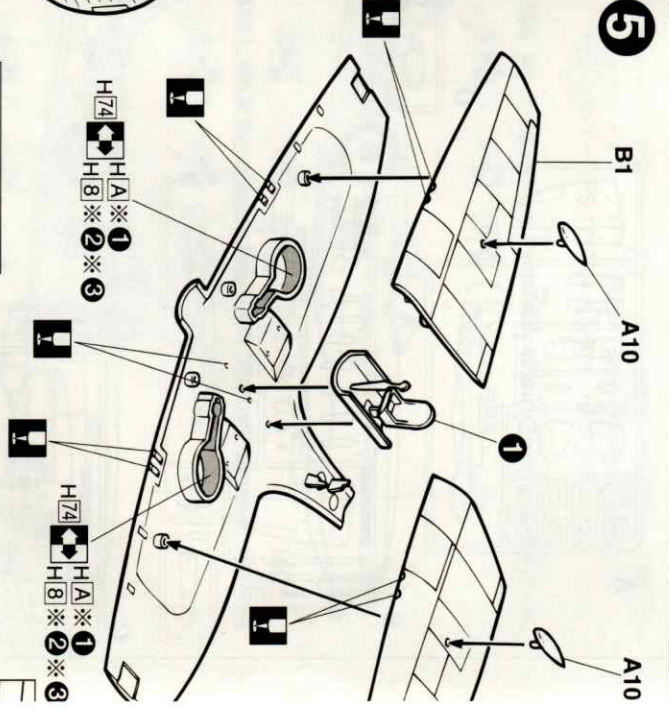

3

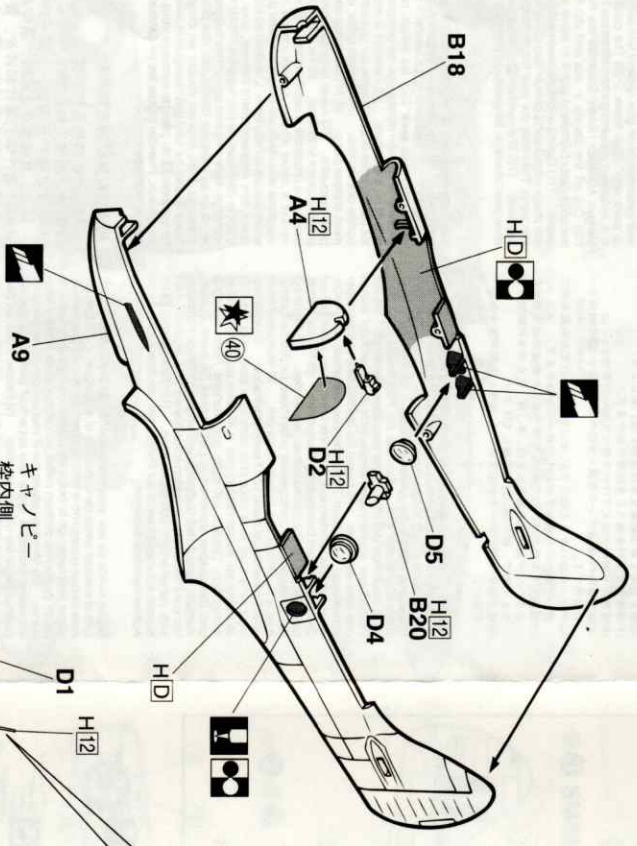

4

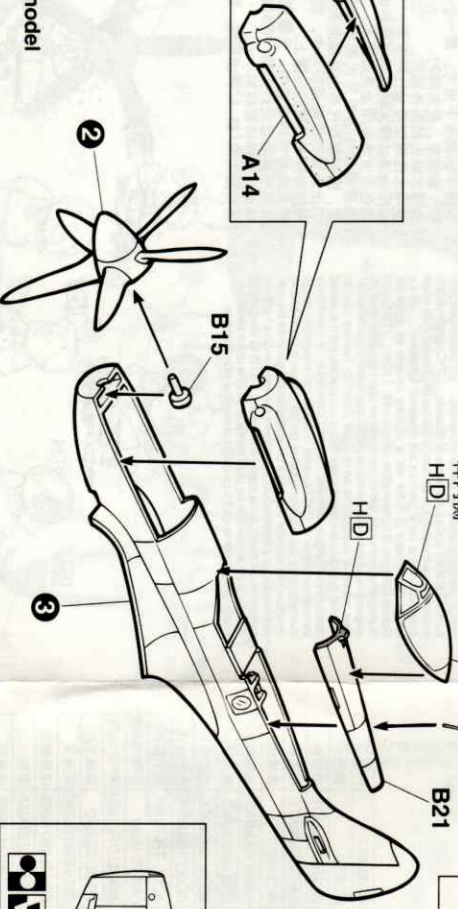

6

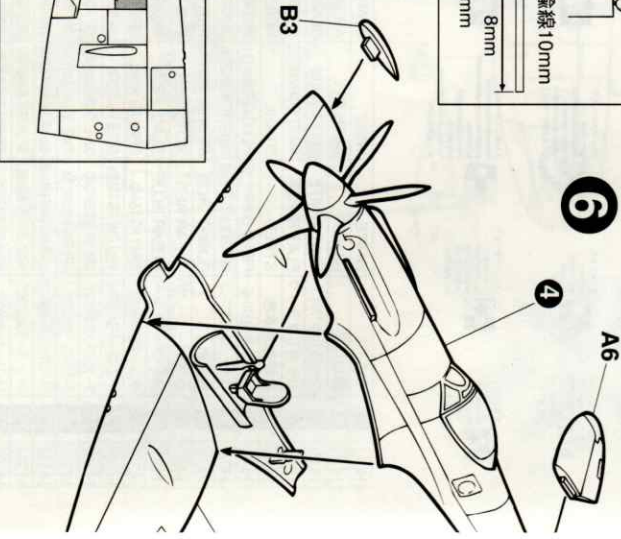

Marking & Painting

※① NM821, "Fochnell", No.2 Squadron, 2nd Tactical Air Force, Germany, 1945-46.

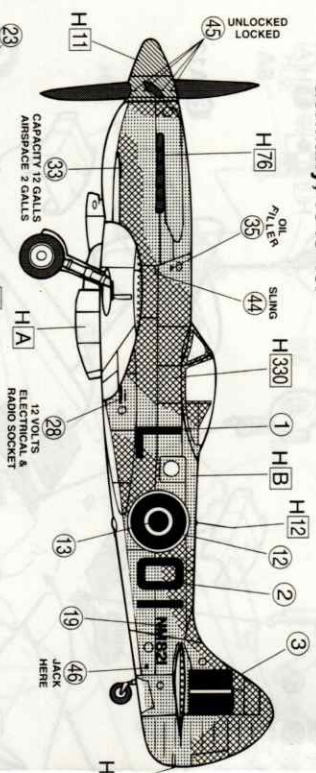

※② TZ164, No.2 Squadron, 2nd TAF, Wahn/Germany, 1948-49.

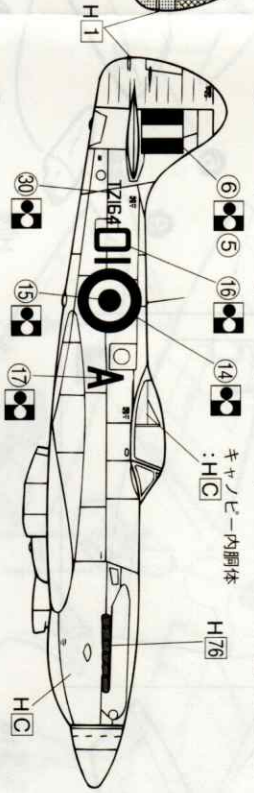

※③ SM883, No.2 Squadron, 2nd TAF, Wahn/Germany, 1948-49.

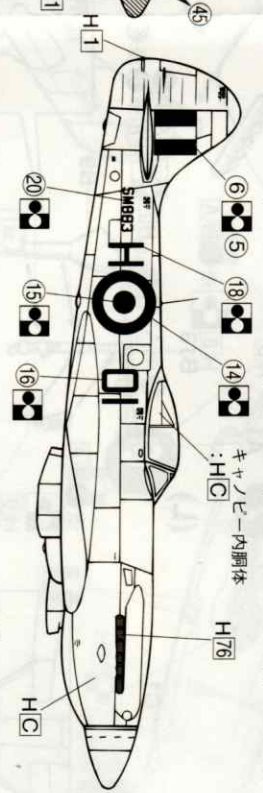

※② ※③

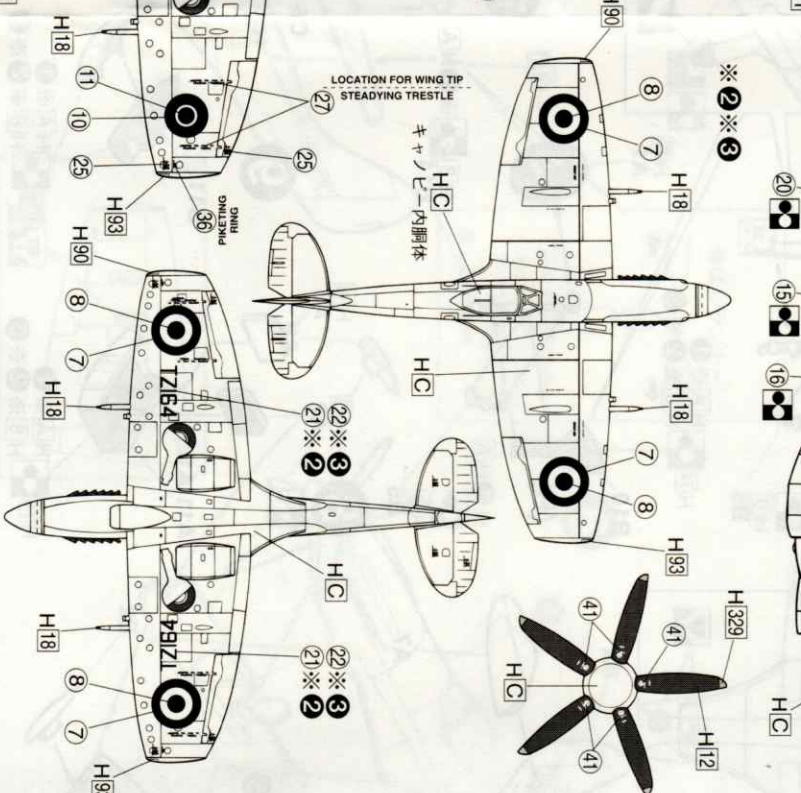
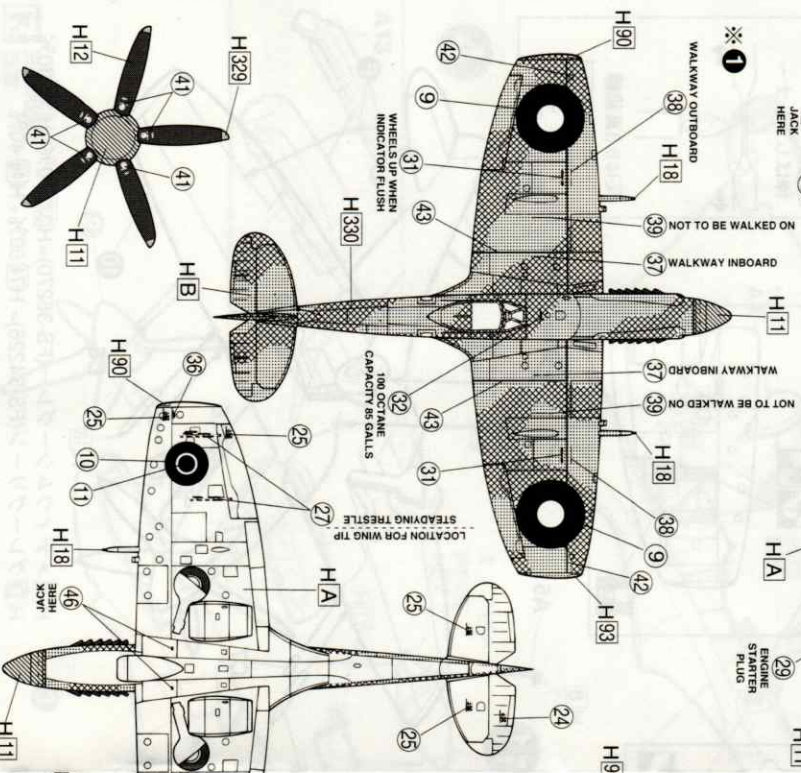
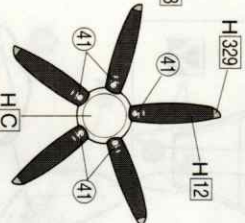

H1Aメテイラム・シー・グラー (FS-36270)=H332 70%+H334 30%
 H1Bオーシャン・グラー (FS-36152)=H335 90%+H331 10%
 H1Cシルバー (FS-17178)=H8180%+H315 20%