

## EC-135C "LOOKING GLASS" AIRBORNE COMMAND POST

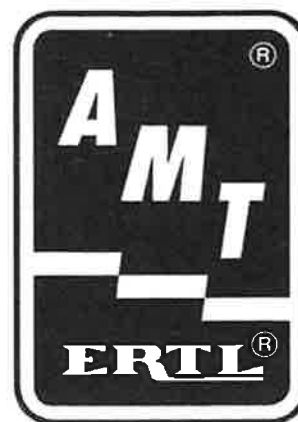

STOCK No. 8955  
FORM No. 099 - 1153

With the development of submarine-launched and intercontinental ballistic missiles, it became clear that in the event of a nuclear war, one warhead could take out the USA's entire command structure. A virtually invulnerable, flexible radio relay/command post had to be identified. The obvious location was airborne, so a group of B-47 bombers were hastily converted into EB-47L's, and the "Looking Glass" mission was born. For over thirty years they were operated by the Strategic Air Command.

The B-47's airframe was small and cramped, leaving little room for equipment and personnel, as well as being a difficult and demanding aircraft to fly. A fast, capacious, sturdy aircraft was needed. The then-new KC-135 was the obvious choice.

The EC-135C is the cornerstone of the Post-Attack Command and Control system. At least one of the aircraft has been in the air at all times from the early 1960s until recent times. In their Airborne Nuclear Command Post ( ABNCP ) role, the EC-135C carries a general officer and 10 crew battle staff who operate communications equipment to provide for the continued direction of the USA's nuclear response in the event of an attack.

Flying with the 2nd ACCS of the 55th SRW at Offutt AFB, Nebraska, the TF33 turbo-fan engine powered EC-135C is supported by a variety of other EC-135 variants tasked with relaying radio communications from the ABNCP aircraft to Air Force assets all over the world.

Most of the EC-135 variants (there at least 13), retain their ability to serve in the in-flight refueling role. Indeed, were it not for a distinctly different paint scheme, from a distance it would be difficult to tell the difference between the EC-135C and the KC-135E. However, up close the myriad of antennae, aerials, satcom blisters and probes make it's role obvious.

Your AMT/Wings Collection kit provides you with markings enabling you to reproduce two of the EC-135C Looking Glass aircraft serving with the 55th SRW. We hope you enjoy building your replica of this important C-135 derivative

Special thanks to the following in the preparation of this kit: Al Lloyd, Bill Strandberg, Alan Griffith, Jennings Heilig, Lloyd Jones, Tom Bly, Boeing Military Aircraft Company, 55th SRW, United States Air Force.

## IMPORTANT

Before you begin to assemble your model kit, study the instructions carefully. This will help you to familiarize yourself with the part locations as you proceed. Prior to cementing parts together, be sure to "TEST FIT" them in order to assure proper alignment and also to check for excess "FLASH" that may occur along parting lines. Use a sharp hobby knife or file to remove flash if necessary.

If you wish to paint your model, various sub-assemblies and components should be painted before any parts are attached. During assembly, you may note that the recommended color is stated after the part name.

This model kit is molded from the finest high-impact styrene plastic. Use only paints and cements which are specifically formulated for styrene. Read all labels and warnings carefully.

Because the cement will only adhere to bare plastic, it is necessary to remove any paint or "plating" from the area to which the cement is to be applied.

### BUILDING TIPS FOR THE ADVANCED MODELER

For the best possible finish, your kit should be painted, even if molded in color. Paint should be applied evenly, in several thin coats rather than one heavy coat. The first coat should not completely cover the surface. Each layer should be allowed to thoroughly dry before the next is applied.

It is important to keep your hands clean when working with your model and wash parts thoroughly before painting to remove any mold release agent that may have been used during manufacture, body oil from your hands, sanding residue, and dust, which is naturally attracted to plastic by static electricity. Use a mild solution of dishwashing detergent and water. A tack rag should be used to dry the parts, DO NOT use paper towels or tissues, since they will leave lint on the part.

Parting lines and glue joints should be sanded or filed prior to painting. Because paint has a tendency to draw away from sharp edges, they should be lightly filed. Use filler putty designed for plastic to fill small gaps that may occur between parts and to blend contours. This should be done only after the first, or "primer," coat of paint is applied.

When painting a multi color scheme, the lightest color should be painted first. Use frosted, or "magic," tape to mask off the area you do not want painted. After the second color is dry to the touch, the tape can be removed. Use a very fine brush to touch up edges if necessary. If decals are to be added, do so before adding any gloss coat. A gloss coat will help even out the edges between the two colors as well as set the decals.

NOTE: Federal standard colors The military services use standardized colors, each receiving a specific five digit identification number. Grays, for instance, are all 6000, and gloss paints begin with a 1, semi-gloss 2, flats 3. Thus a gray color can be gloss ( 16251 ), semi-gloss ( 26251 ) or flat ( 36251 )

### RECOMMENDED TOOLS

#### HOBBY KNIFE

Use a sharp hobby knife to remove parts from the trees. The knife may also be used to remove parting lines and flash.

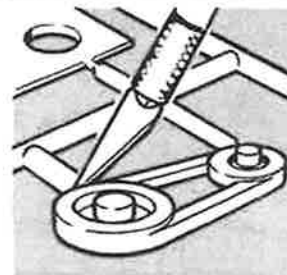

#### TWEEZERS

Use tweezers to hold small parts during assembly, painting and when applying cement.

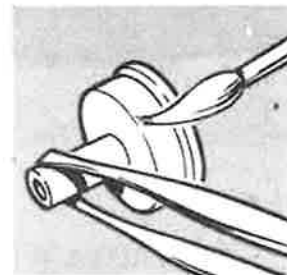

#### BRUSH

We recommend the use of liquid polystyrene cement. Apply with a fine brush. Use sparingly or a sloppy job will result.

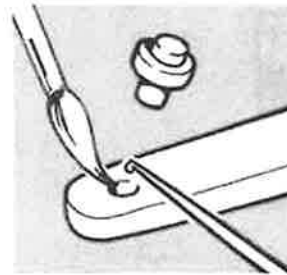

### READ ALL LABELS AND WARNINGS CAREFULLY

We take great pride in providing the finest model kits available, giving strong attention to detail and craftsmanship. Should you have any difficulty with assembly or missing parts, please call the appropriate number listed below between the hours of 8:00 am to 4:30 pm central time, Monday through Friday.

In the U.S.A. call toll free

800 - 553 - 4886

Outside of the United States call

1 - 319 - 875 - 2000

When in the Midwest, please visit the ERTL Company for a tour of the AMT production facilities, 10am & 1pm weekdays. Reservations suggested.

### DECAL APPLICATION INSTRUCTIONS

- Choose the decals you want to put on your kit and use a scissor to cut it from the decal sheet.
- Dip the decal in a cup of luke warm water for about fifteen seconds to loosen the decal from the backing paper.
- Place the decal in position and slide the decal off the backing paper and onto the model.
- Use a soft, damp cloth to gently rub away any water bubbles under the decal.

**The ERTL COMPANY, Inc.**

P. O. Box 500  
Dyersville, Iowa 52040 - 0500

# DECAL APPLICATION

- Light gray FS 16473
- Matte black
- Glossy white
- Polished metal

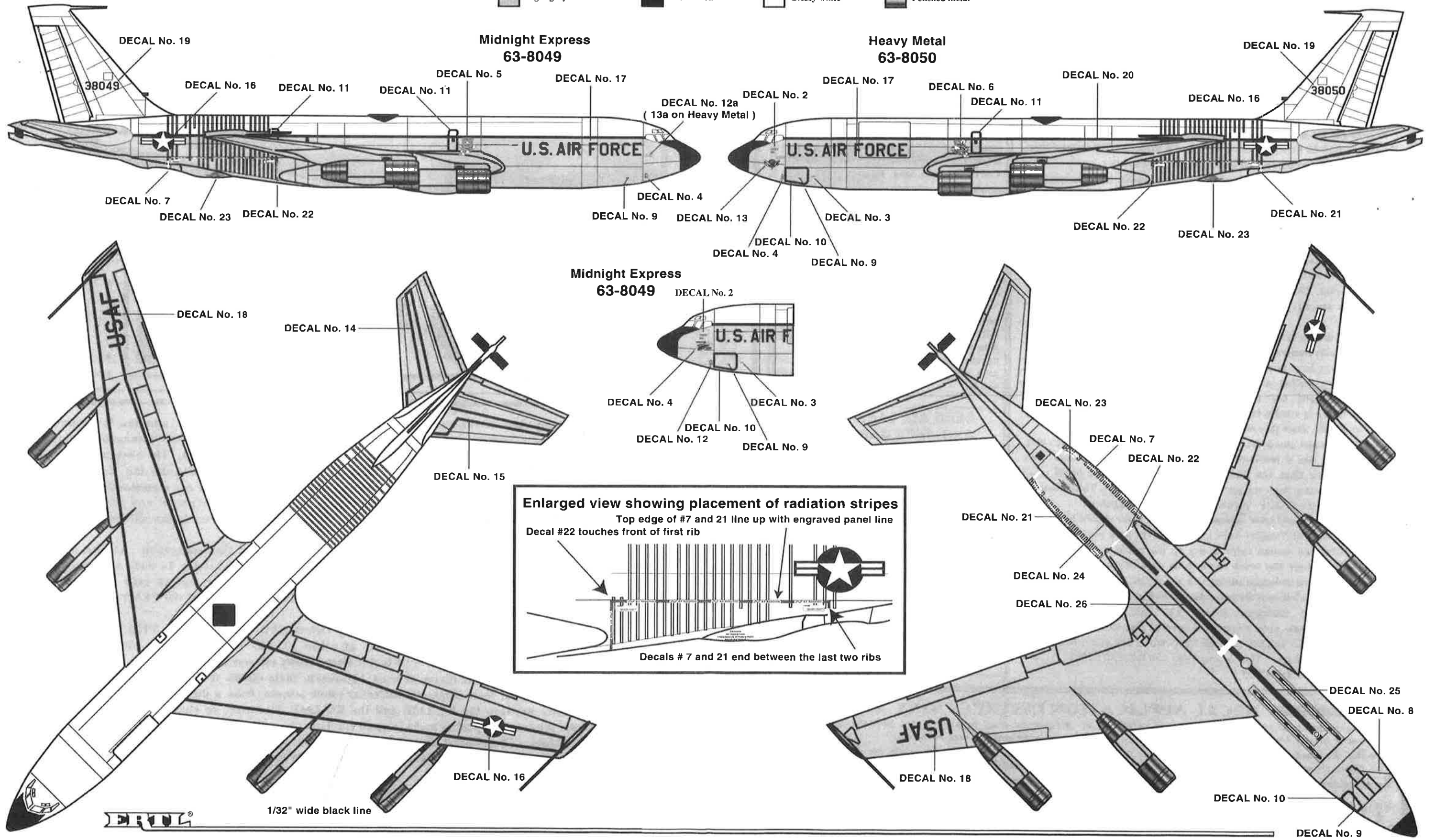



EC-135C "LOOKING GLASS"  
**AIRBORNE  
COMMAND  
POST**

STOCK No. 8955 Familiarize yourself thoroughly with the instructions before you begin. History, modeling tips and decal application are on the supplemental instruction sheet.

FORM No. 099 - 8955

**COLOR SELECTION**

This kit includes the suitable markings to build one of two versions of the EC-135C. Listed below are the colors needed to accurately complete your model. Corresponding Federal Standard numbers are included where appropriate.

Flat Gull Gray	FS - 36440
Light Ghost Gray	FS - 36375
Insignia Red	FS - 31136
Dark Gull Gray	FS - 36231
Insignia Yellow	FS - 33538
Aircraft Gray	FS - 16473
Flat White	
Flat Black	
Semi-Gloss Black	
Orange	
Aluminum Plate	
Aluminum	
Yellow	
Gloss White	

Fig. 1: Paint the parts and assemble as shown.  
NOTE: Paint PILOT, CO-PILOT, NAVIGATOR and BOOM OPERATORS SEAT backs Light Ghost Gray. Paint the consoles and seats Dark Gull Gray. Paint seat cushions and headrests ( Shaded Area ) Insignia Red.

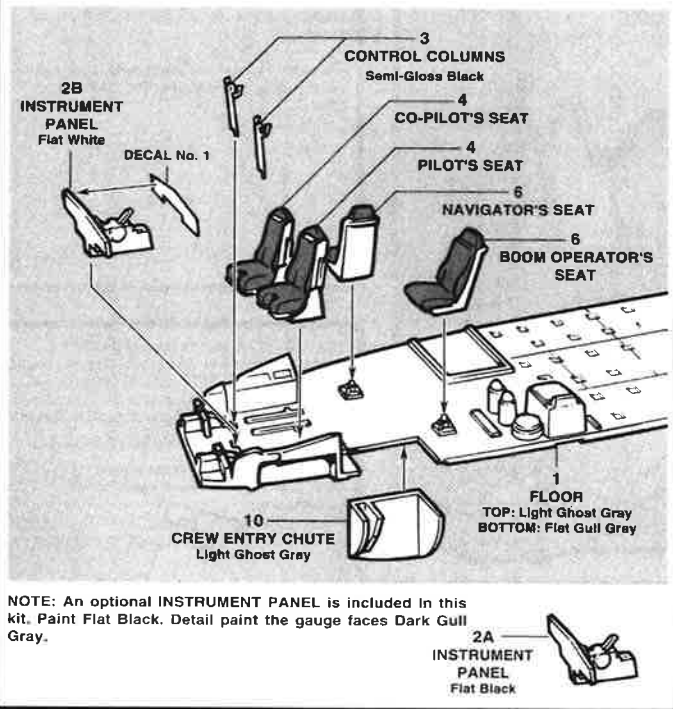

NOTE: An optional INSTRUMENT PANEL is included in this kit. Paint Flat Black. Detail paint the gauge faces Dark Gull Gray.

Fig. 2: Paint the parts and assemble as shown.  
NOTE: Paint the parts shown here Dark Gull Gray prior to assembly. Detail paint the individual parts as indicated.

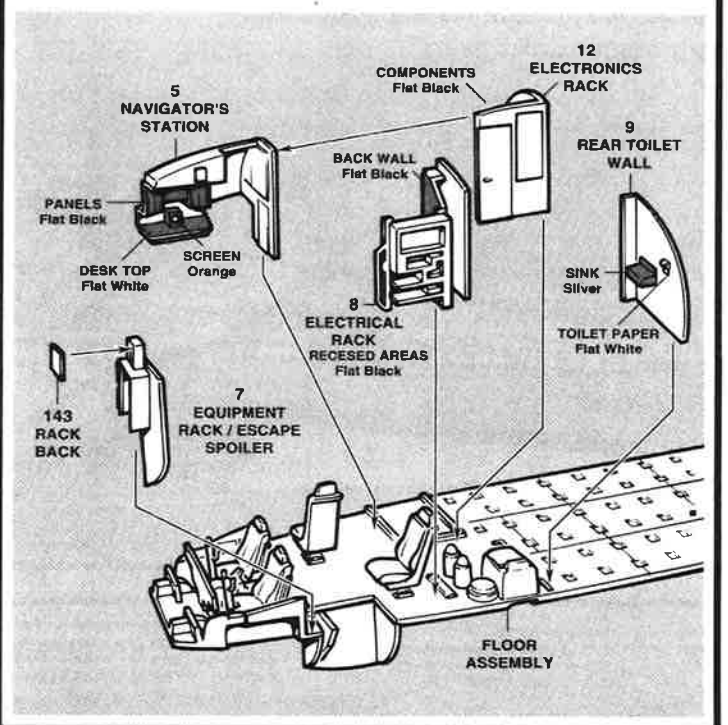

Fig. 3: Paint the parts and assemble as shown.  
NOTE: Paint the inside of both BOOM HALVES Zinc Green Chromate. If using the DROGUE HOSE paint the ends ( Shaded Area ) Flat Gull Gray.

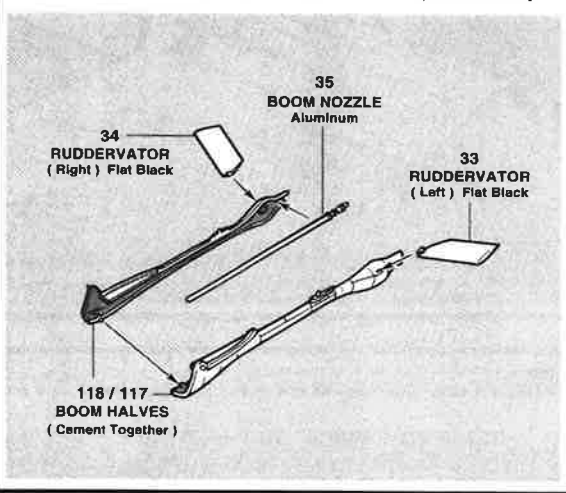

Fig. 4: Paint the parts and assemble as shown.  
NOTE: Paint the A P U, BOOMER'S COMPARTMENT and REAR BULKHEAD Light Ghost Gray. Paint the OXYGEN TANKS Insignia Yellow. Paint seat cushions ( Shaded Area ) of the BOOMER'S COMPARTMENT Insignia Red.

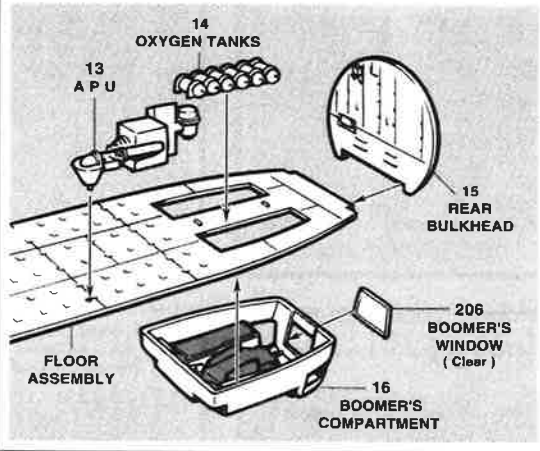

Fig. 5: Paint the parts and assemble as shown.  
NOTE: Cement both the front and rear MAIN GEAR BULKHEADS to the WATER TANK HOUSING and paint Aircraft Gray. Cement the WATER TANK HOUSING to the FLOOR ASSEMBLY as shown.

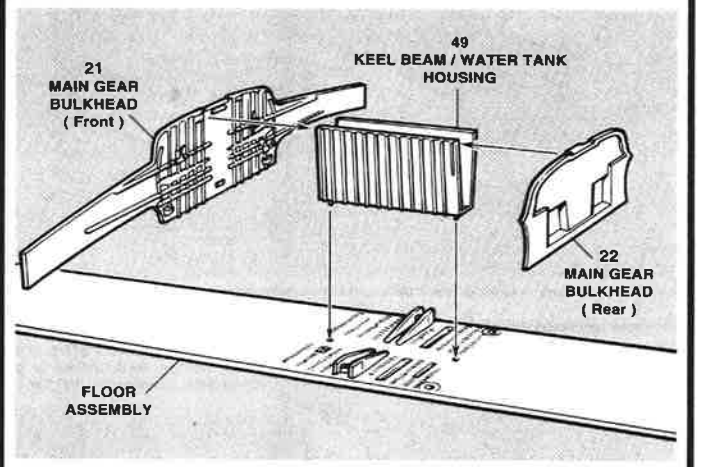
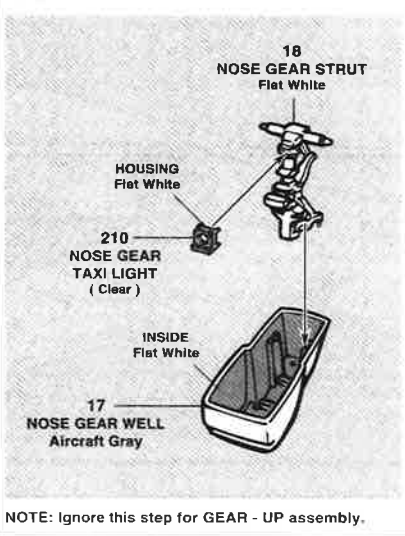

Fig. 6: Paint the parts and assemble as shown.  
NOTE: Paint the NOSE GEAR STRUT, the inside of the NOSE GEAR WELL ( Shaded Area ) and all but the center circle of the NOSE GEAR TAXI LIGHT Flat White.



NOTE: Ignore this step for GEAR - UP assembly.

Fig. 7: Paint the parts and assemble as shown.  
NOTE: Paint the inside ( Shaded Area ) of the BOOMER'S WINDOW COVER Zinc Green Chromate.

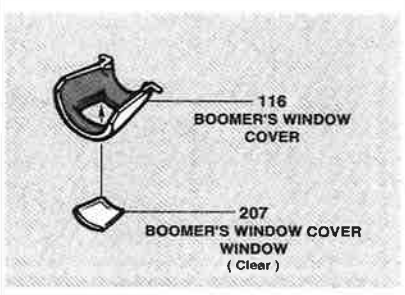

Fig. 8: Paint the parts and assemble as shown.  
NOTE: If you wish to build your model in an in-flight configuration with the doors closed and the landing gear up you should cement these parts in place at this time. These parts are the CREW DOOR (# 112), CARGO DOOR (# 114) Ref. Fig. 12, The NOSE GEAR DOOR (# 113), both MAIN GEAR WHEEL WELL DOORS (# 129: Right and 130: Left) and both MAIN GEAR STRUT DOORS (# 127: Right and 128: Left) Ref. Fig. 14. Paint the inside ( Shaded Area ) of both FUSELAGE HALVES Light Ghost Gray. To assemble with the landing gear lowered cement the ASSEMBLED NOSE GEAR WELL to the right FUSELAGE HALF and the ASSEMBLED INTERIOR to the left FUSELAGE HALF. Add approximately 20 grams of weight to the inside of the nose of the model and cement both halves of the fuselage together trapping the ASSEMBLED BOOM and BOOMER'S WINDOW COVER in place. Cement the BOOMER'S HOUSING to the bottom of the FUSELAGE and the various clear parts in place.

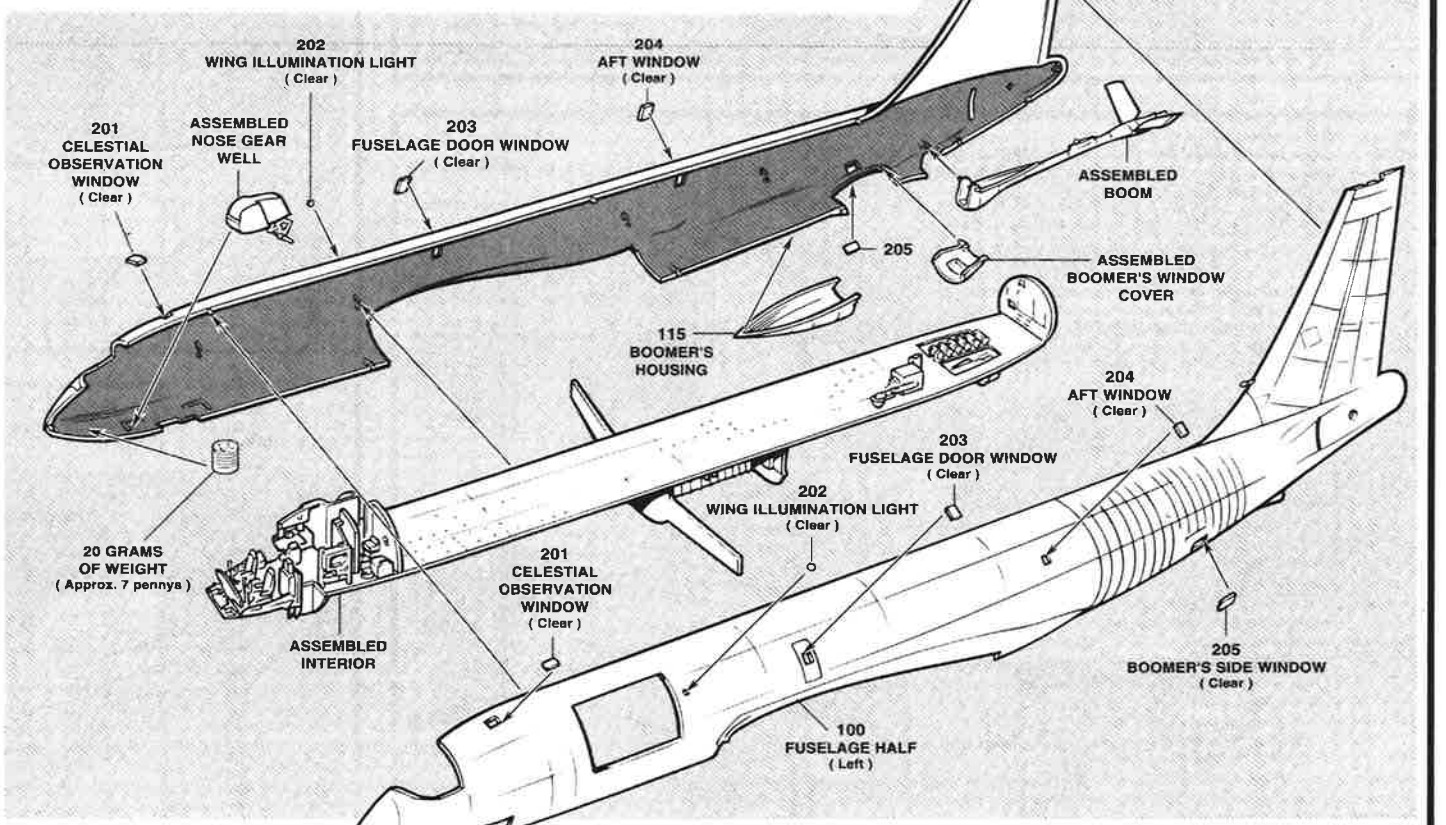

Fig. 9: Assemble the parts as shown.  
NOTE: Paint the interior inside sections ( Shaded Area ) of both UPPER WINGS Flat White as indicated. Cement both parts of the left WING together. Cement both parts of the right WING together. Cement the FUSELAGE and LOWER WING center together. Cement the right and left WINGS in place as shown.

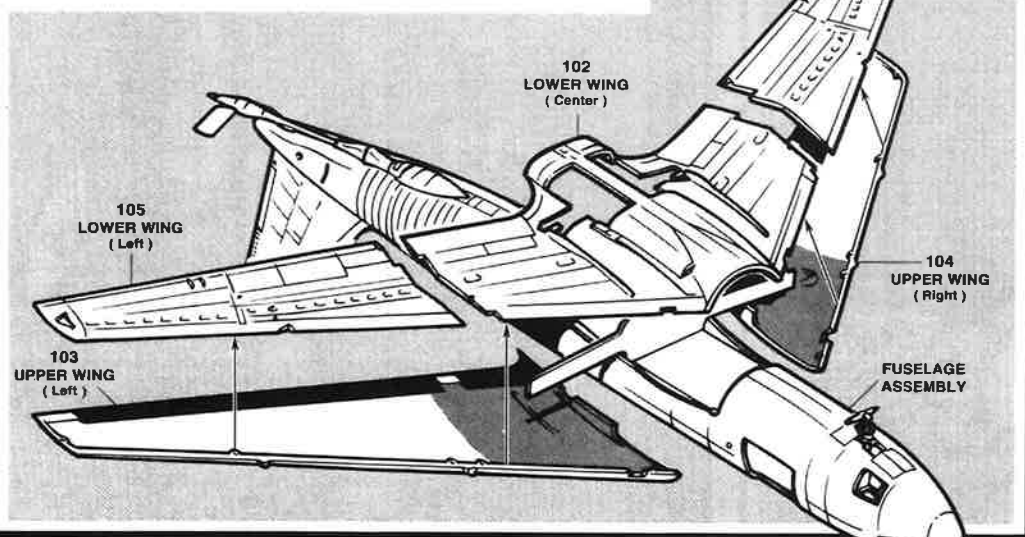

Fig. 13: Assemble and paint as shown.  
NOTE: Cement both halves of the two MAIN WHEELS together and paint as indicated. Cement the MAIN GEAR BRACE and two GEAR EQUALIZER LINKS to the MAIN GEAR STRUT as shown.

Assembly shown for right side, Left side assembly is same except for MAIN GEAR STRUT.

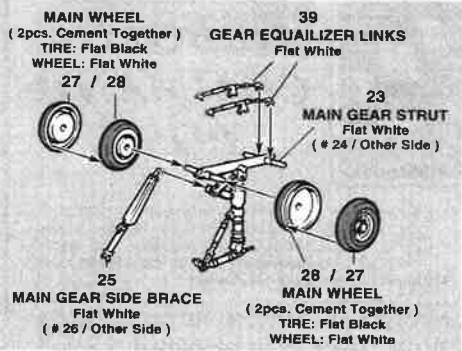

Fig. 14: Paint and assemble as shown.  
NOTE: Cement both halves of the two NOSE WHEELS together and paint as indicated. Cement both MAIN GEAR ASSEMBLIES in place. Paint the inside of both MAIN GEAR WHEEL DOORS and both GEAR STRUT DOORS Light Gull Gray and cement in place. Paint the inside of the NOSE GEAR DOOR Light Gull Gray and cement in place. Cement both NOSE WHEELS to the NOSE GEAR STRUT.

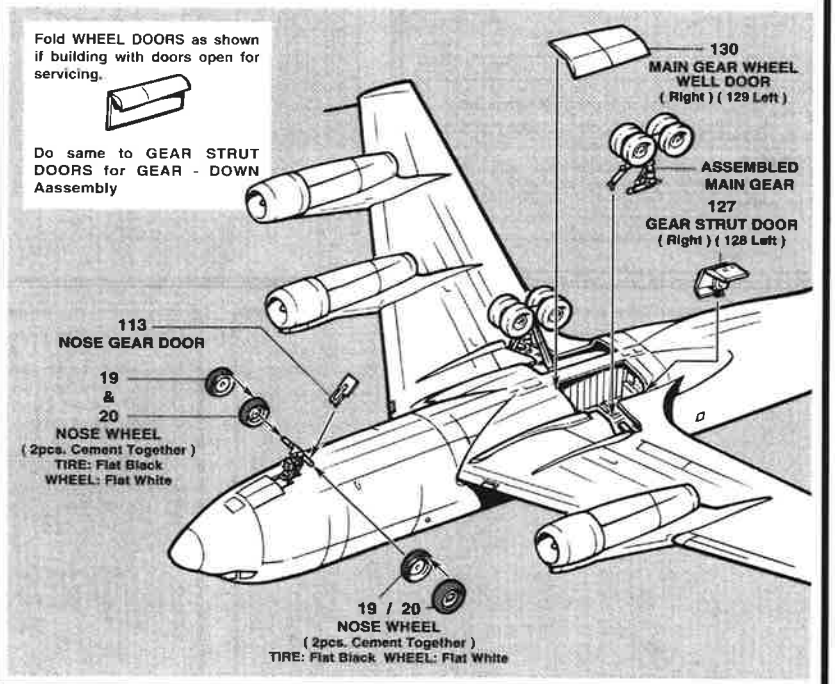

Fig. 10: Paint and assemble as shown.  
NOTE: Assemble two inboard and two outboard ENGINES as shown. Cement one inboard and one outboard ENGINE to the bottom of each WING. Cement each F H TUNER ANTENNA in place .5" from and parallel to wing tips.

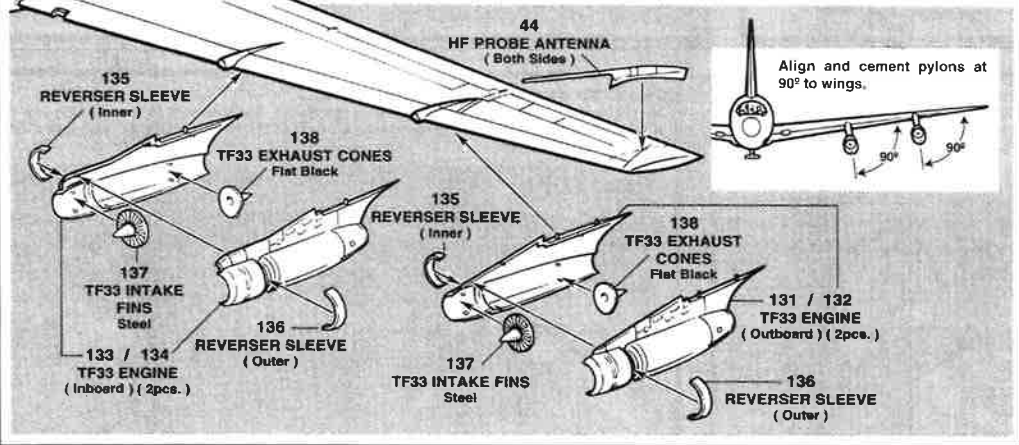

Fig. 11: Assemble the parts as shown.  
NOTE: Cement both halves of each STABILIZER together and cement to the FUSELAGE. Cement the FIN TIP in place.

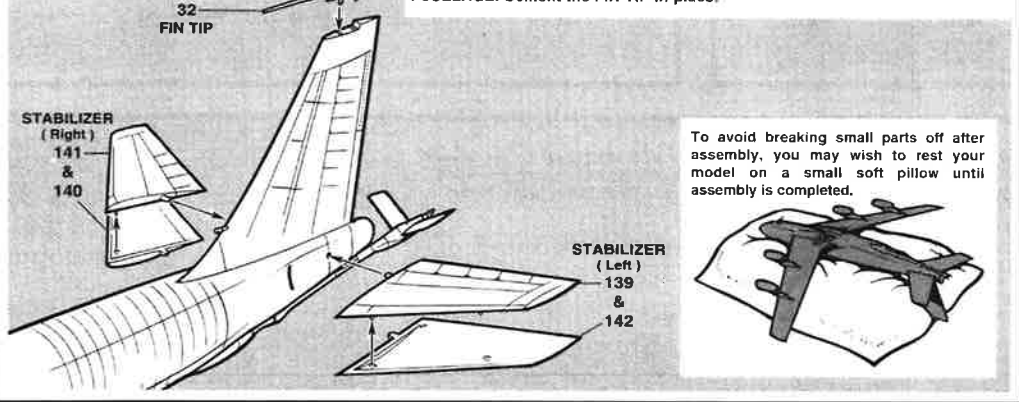

Fig. 12: Paint and assemble as shown.  
NOTE: Paint the inside of the CREW DOOR and CARGO DOOR Flat Gull Gray. Carefully trim the hinges from the CREW DOOR and cement in place if you want the door closed. CARGO DOOR STRUTS: Not used for door closed configuration. SIDE MOUNT ANTENNA: Locate .25" behind and top edge level with AFT WINDOW. NAVIGATION BLISTERS: Locate front edges 7.5", 8.75" and 12.75" from front of nose. SADDLE ANTENNA: Locate front edges 10.25" from front of nose.

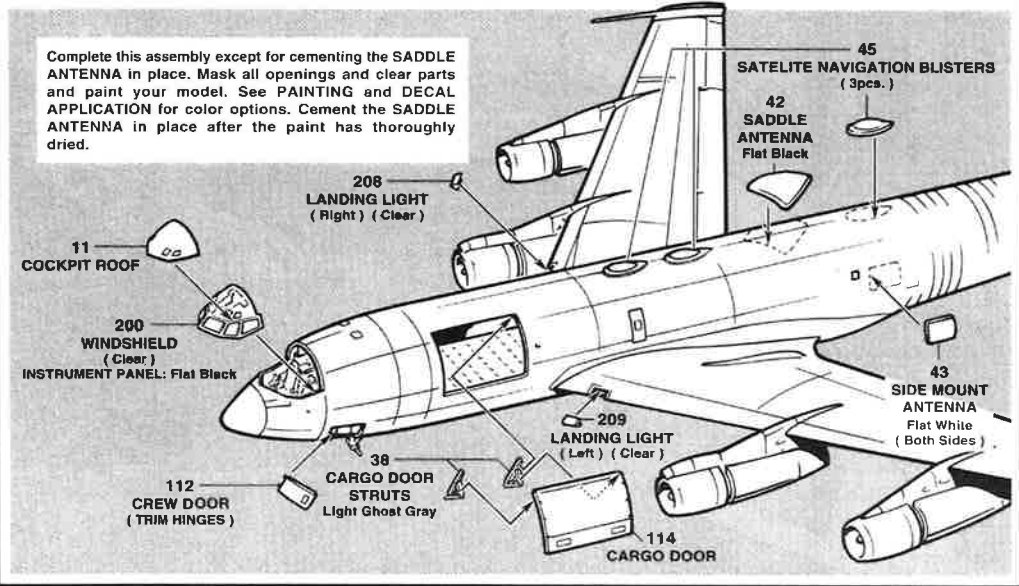

Fig. 15: Paint and assemble as shown.  
NOTE: Paint the DIRECTIONAL REFUELING LIGHTS as indicated and cement in place. Letters F, A, D and U are used for alignment.

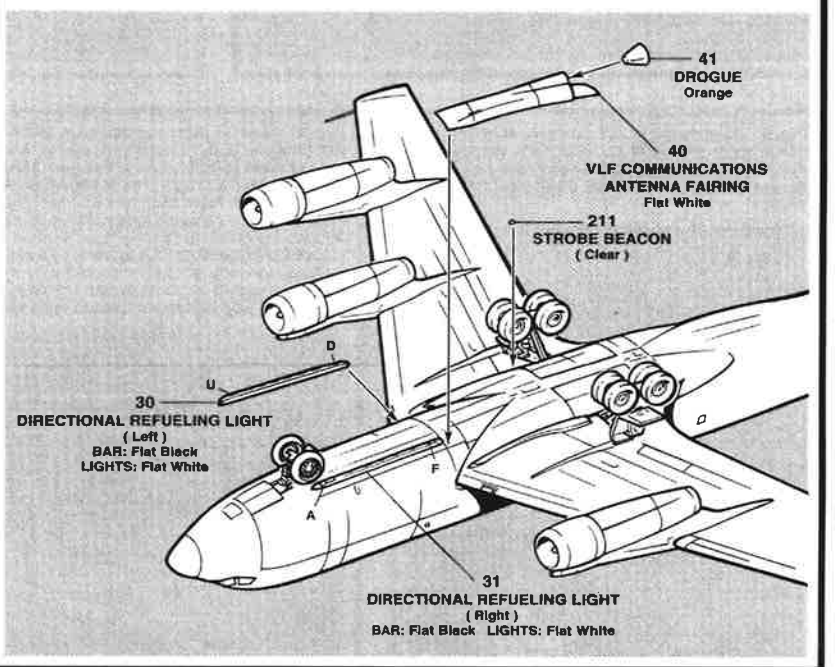

Fig. 16: Paint and assemble as shown.  
NOTE: The TAIL SUPPORT STRUT is optional for GEAR - DOWN configuration.

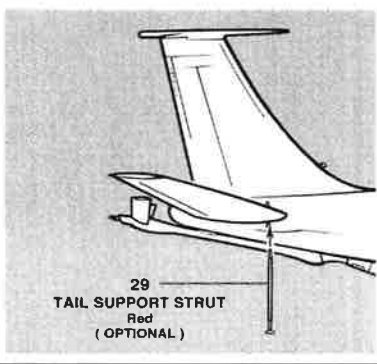

Fig. 17: Paint and assemble as shown.  
NOTE: The CREW LADDER is optional for GEAR - DOWN configuration. Ladder hooks inside and should not touch ground.

