

CMP C15TA Armored Ambulance

Precision plastic model

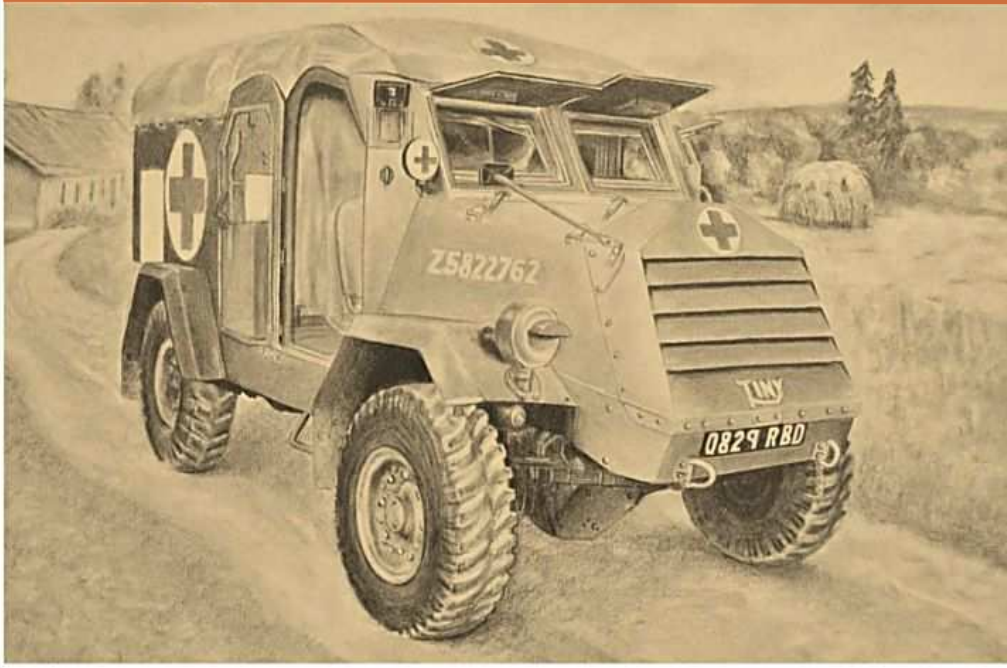

**1/35
Scale**

**Kit No.
35106**

The C15TA Armoured Truck was developed by GM Canada along a concept lines of the American M3 Scout Car. The vehicle used the chassis of the Chevrolet C15A Canadian Military Pattern truck design. Between 1943 and 1945 a total of 3,961 units were built in Oshawa, Ontario. Armoured hulls were supplied by the Hamilton Bridge Company

The C15TA was used by the British and Canadian units in the Northwest Europe campaign as armoured personnel carrier and ambulance. After the end of the hostilities, many vehicles were left in Europe and were subsequently employed by armies of the liberated European countries, including Belgium, Denmark, the Netherlands, Norway. In addition about 150 were sold by Canada to Spain. Trucks left by the British forces in Vietnam were taken over by the French, which used them in Indochina and later transferred to South Vietnam. Many C15TAs were employed by the police forces of the Federation of Malaya. In 1955 Portugal received a number of vehicles, which were later used in the African wars. Some vehicles remained in service until the 1960s.

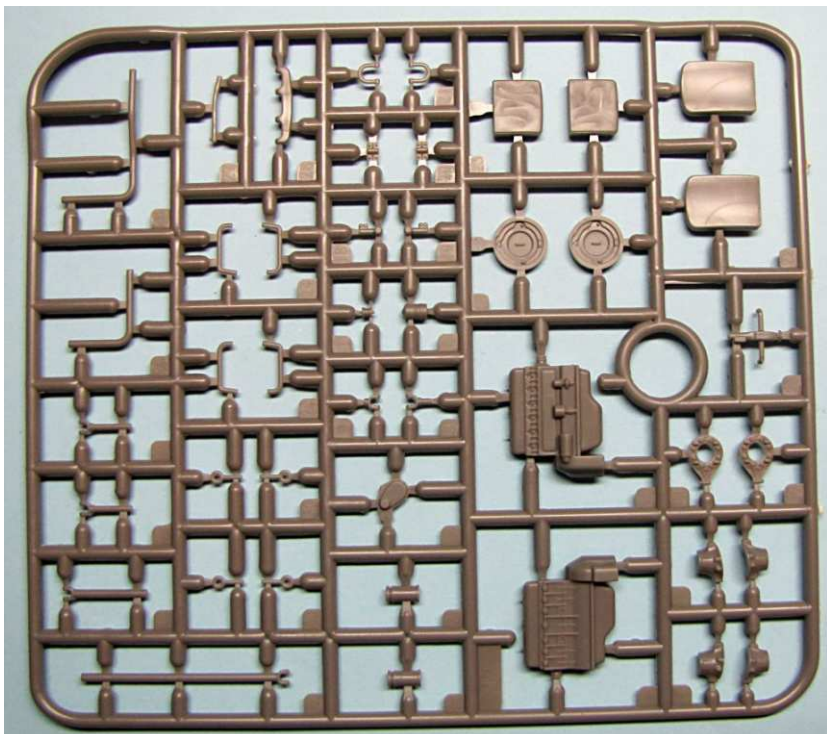

Z

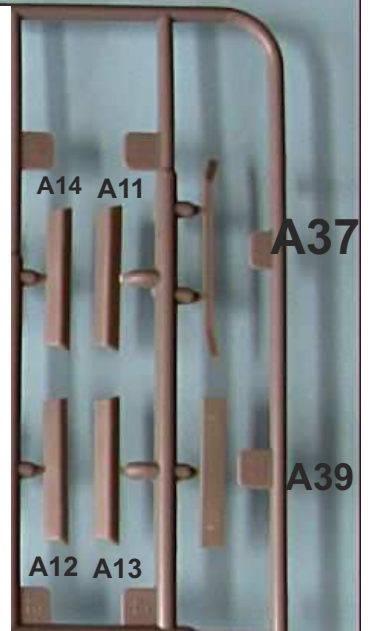

A

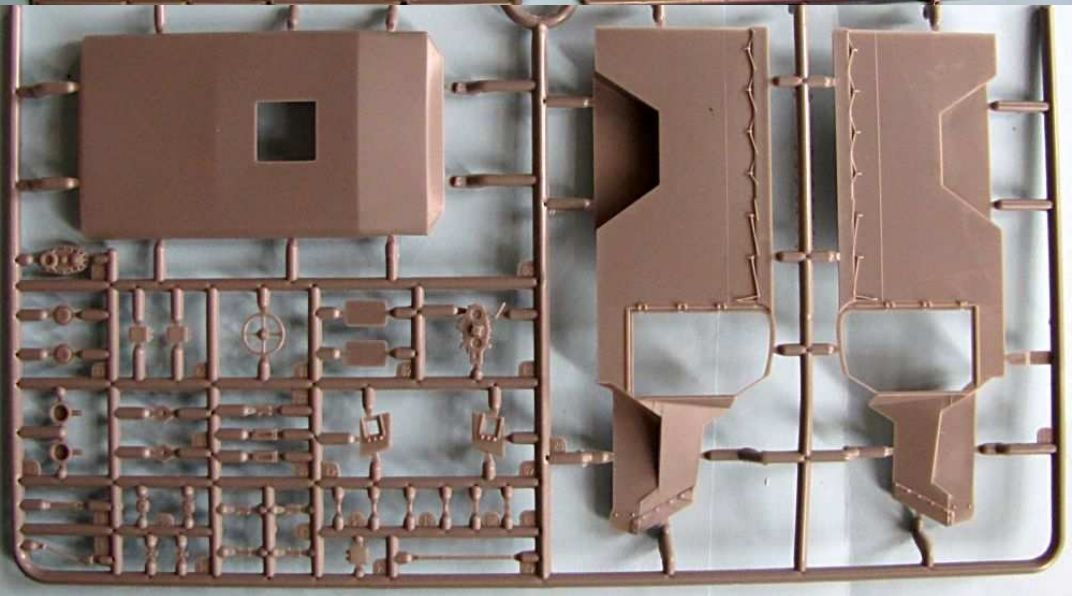
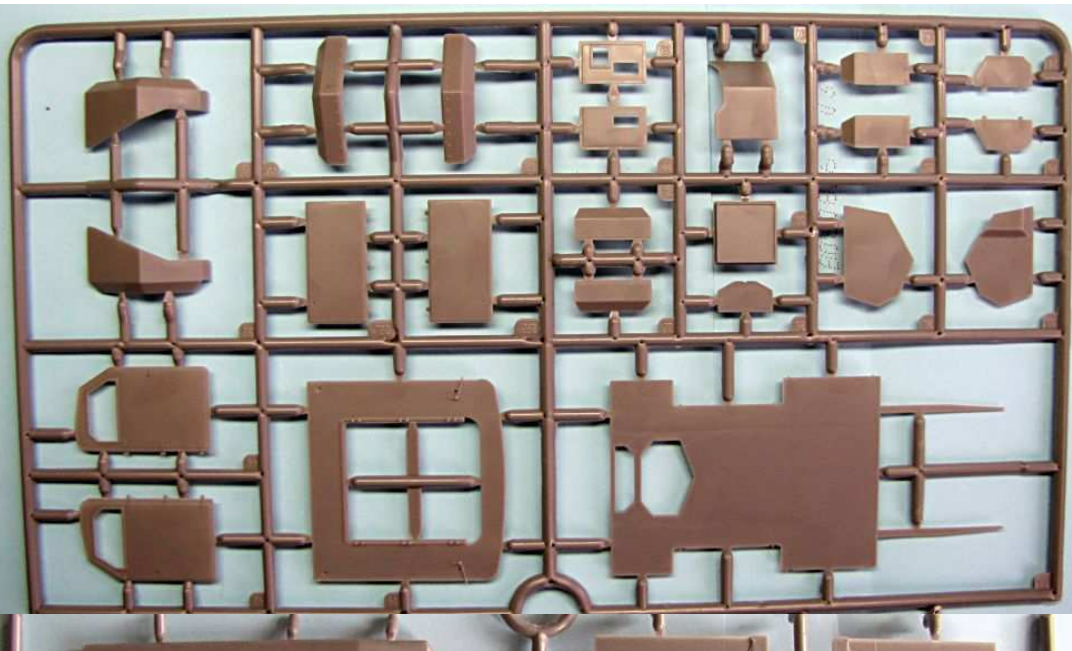
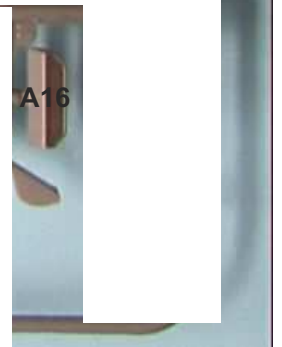

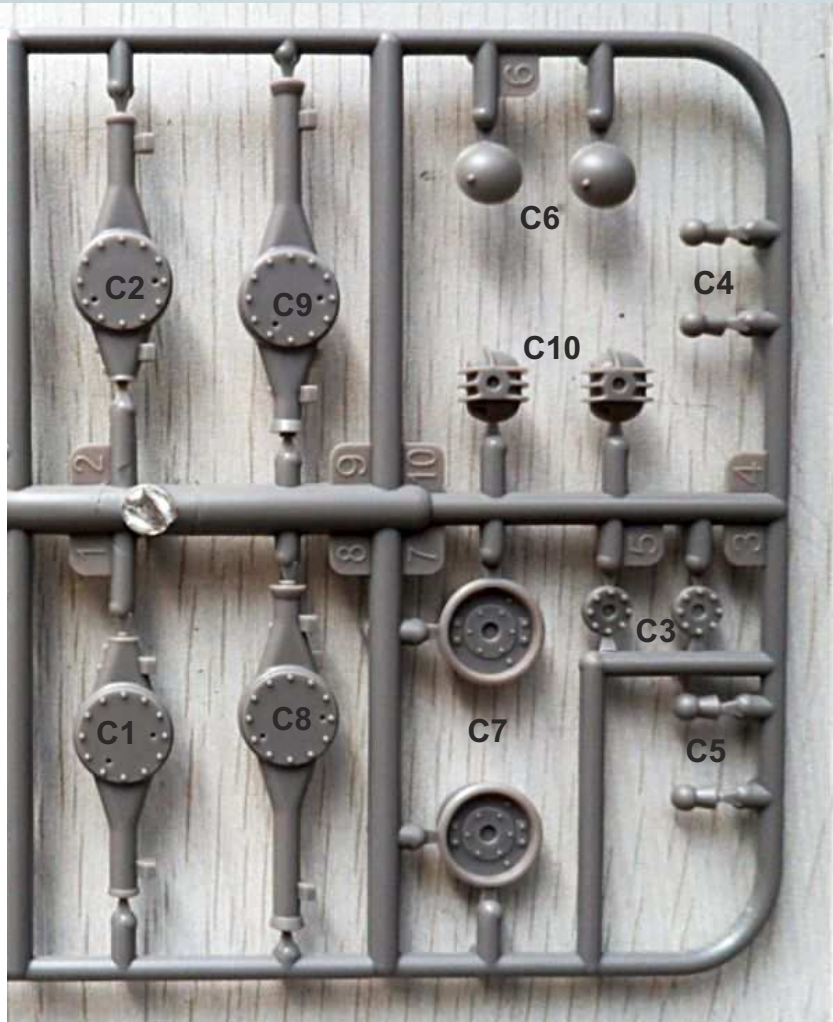
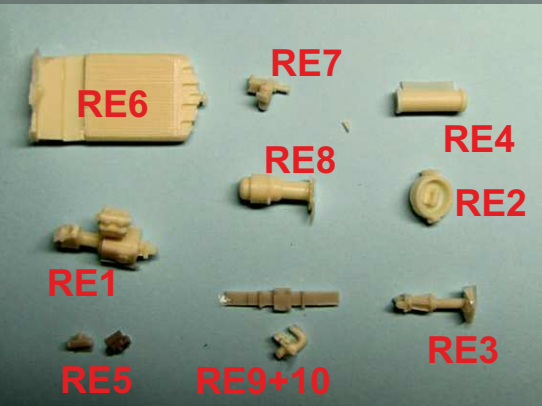
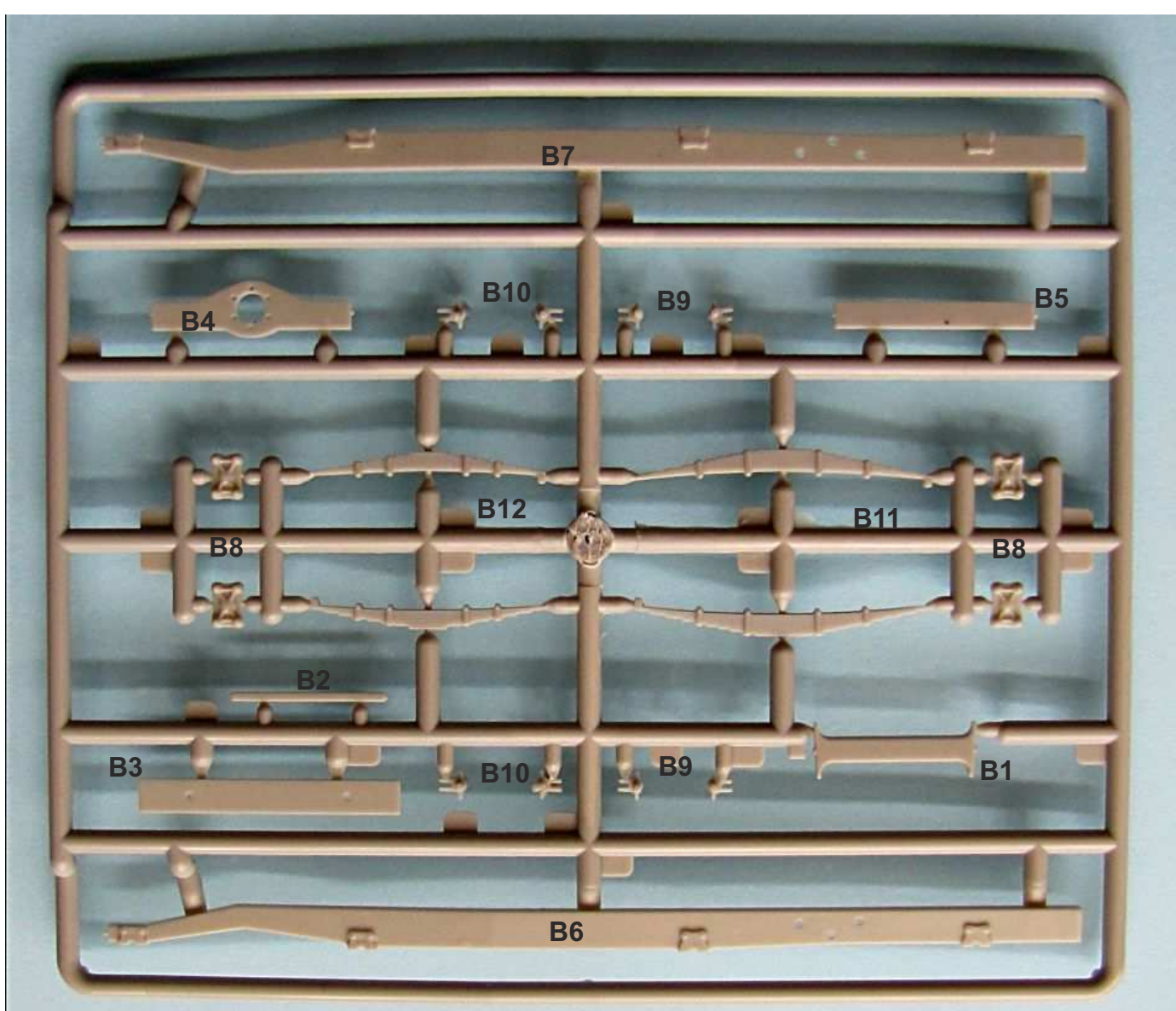

Go through assembly guide before you start your work. Extended Assembly guide and part list to download at www.Mirror-models.com Assembly guide based on test sprue samples, which dont have quality of final product, features like molded canvas rope and some hinges and details are not present in pictures, but will be found on the final kit

Heat up PE parts with lighter before use, brass will soften and become easy to bend and work with Tamiya Super Thin Glue recommended for plastic parts

pins on crossbeams into holes in frame sides

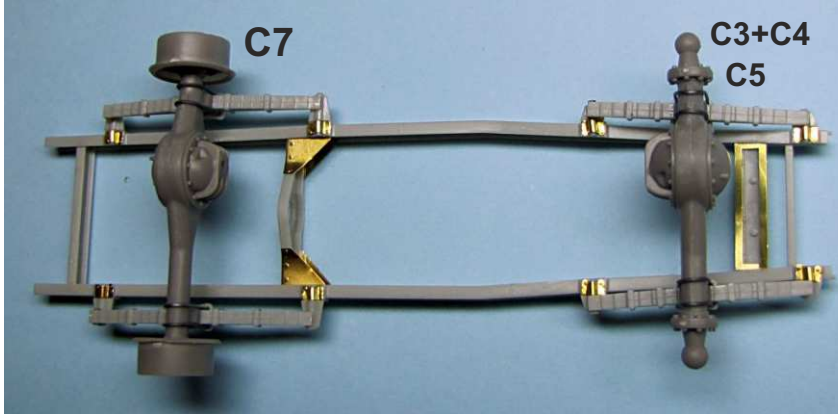
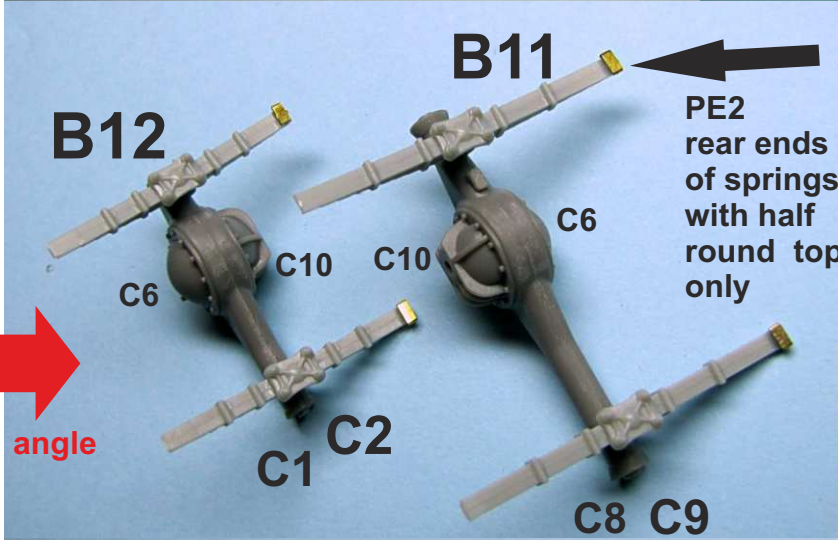
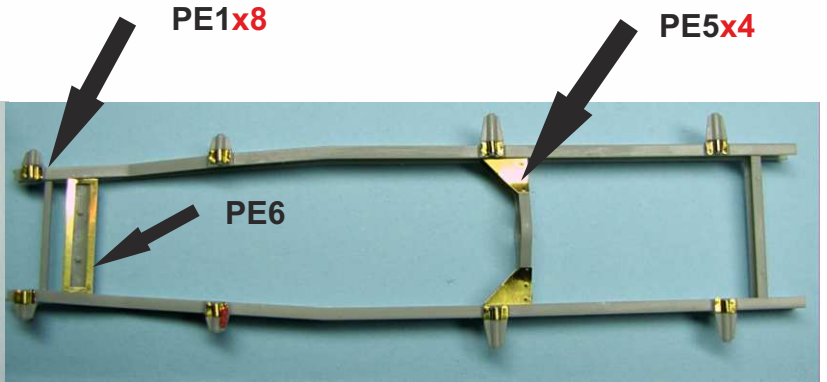
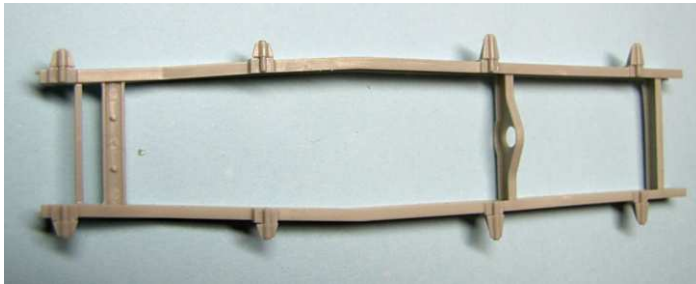
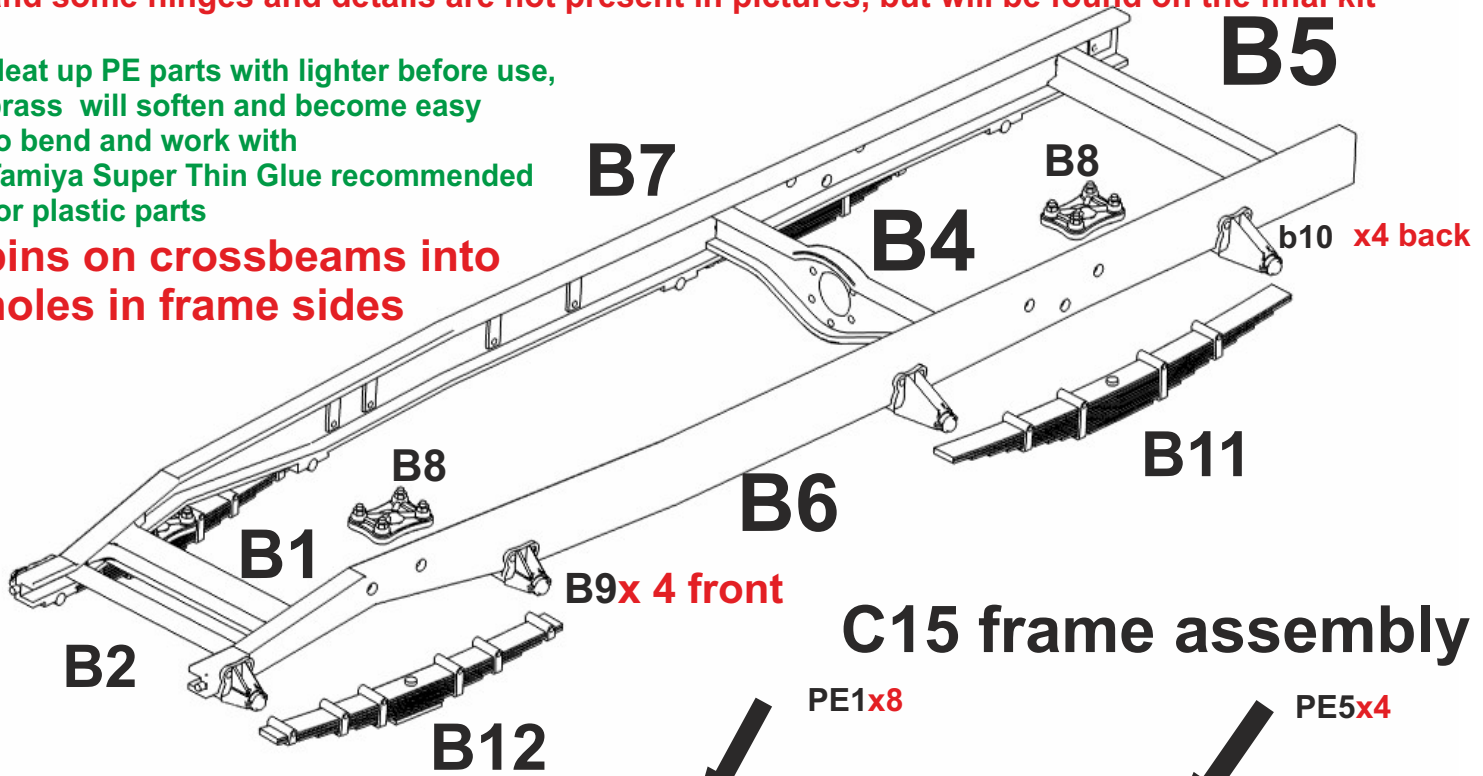

Set angle between front springs according to angle between front holders B9 before you glue springs on C1+C2, check before glue dries... Make ties with 0,5mm wire and then glue both differentials on their holders. Add C3-C5 and C7

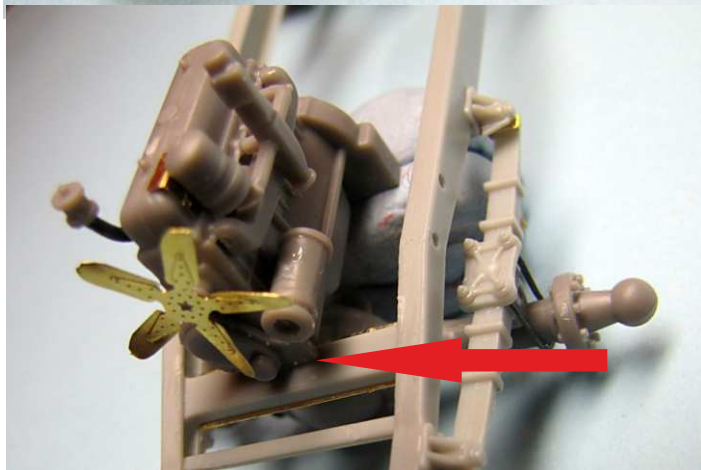
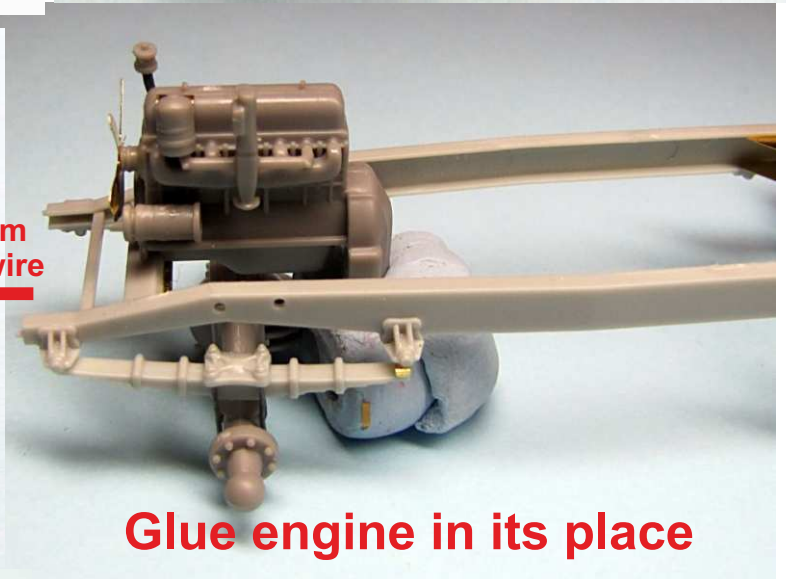
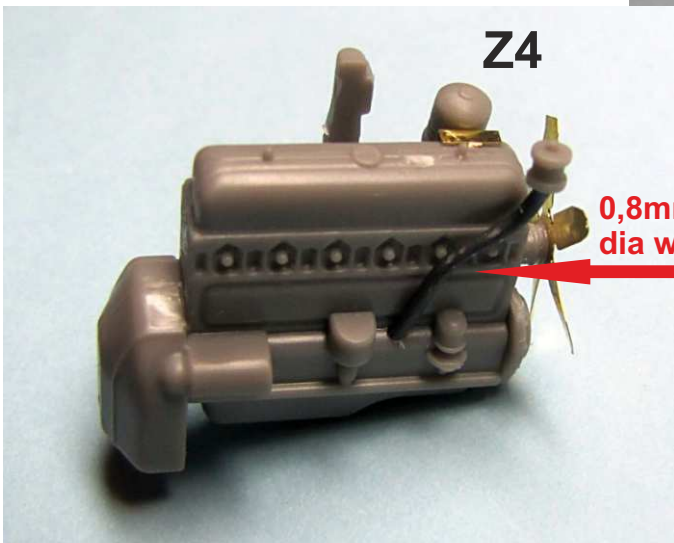
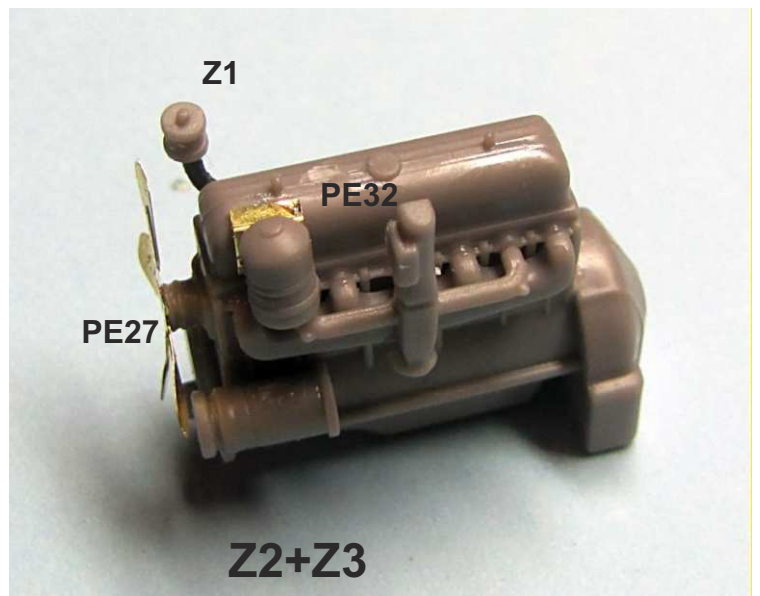
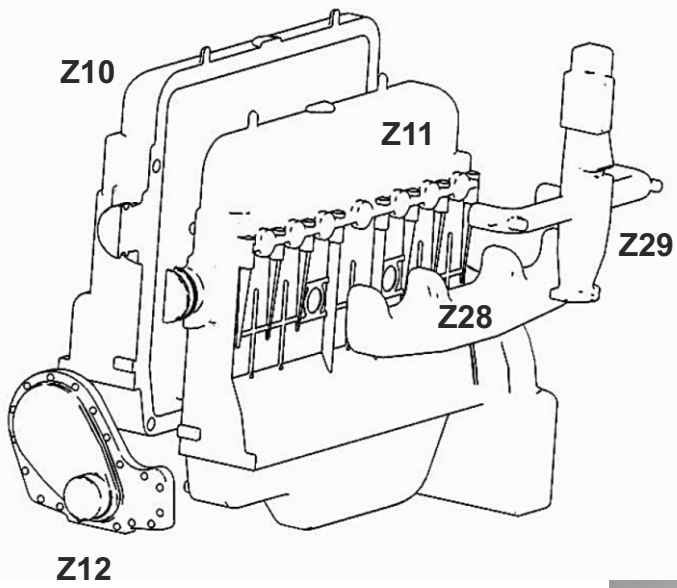

Now you should leave frame assembly and build up the body base that will be needed to fit gear boxes properly and easy. Once body base is ready, return here and finish the frame

complete Z8+Z9, A52+A53, A54+A55 and assemble

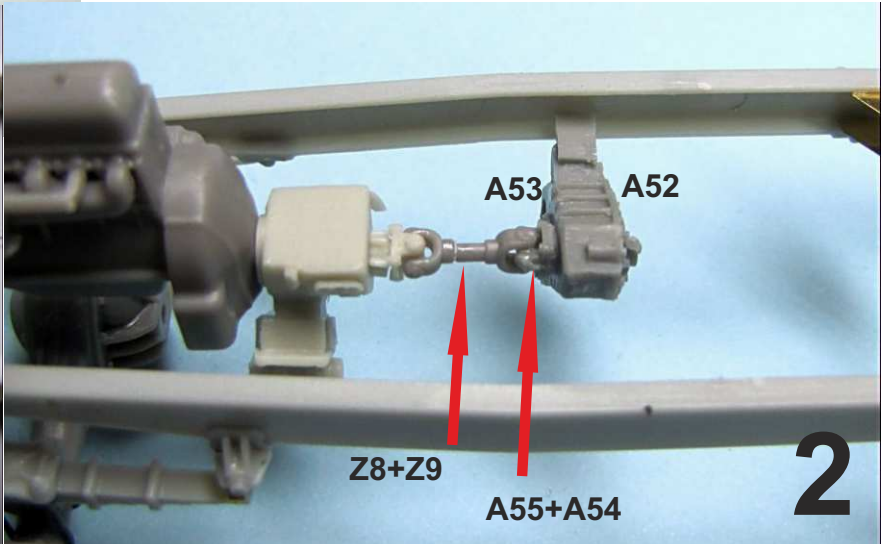
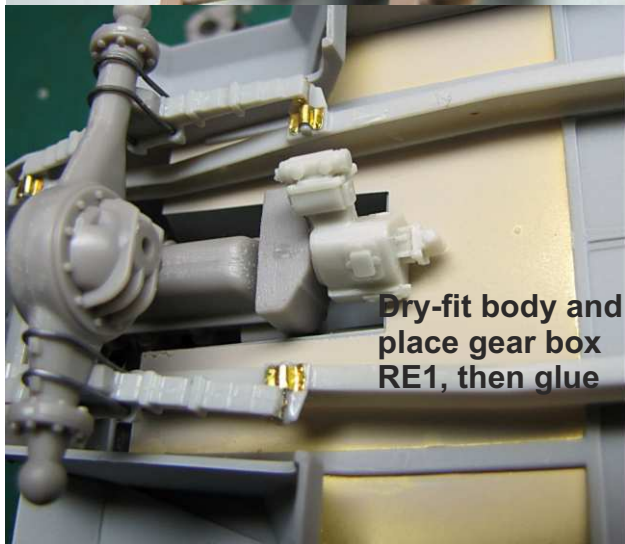

PE4

PE3

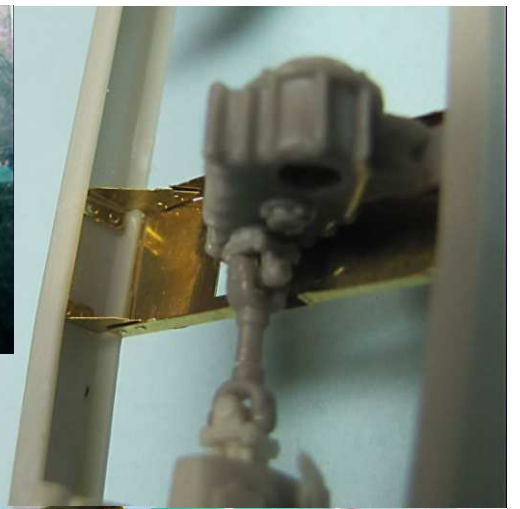
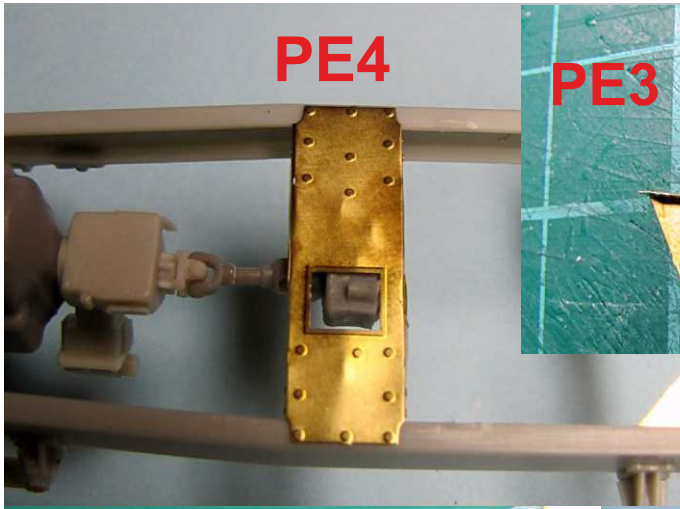

PE7x2

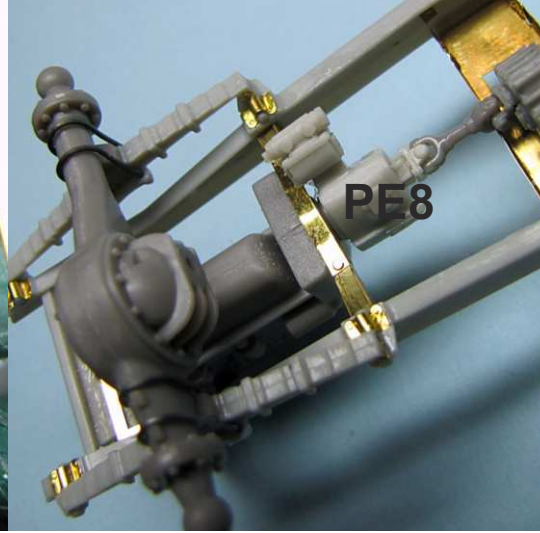

PE7

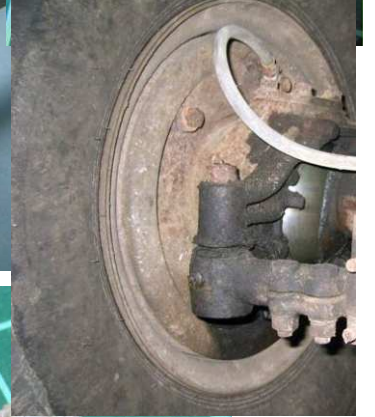

Z14

Z13

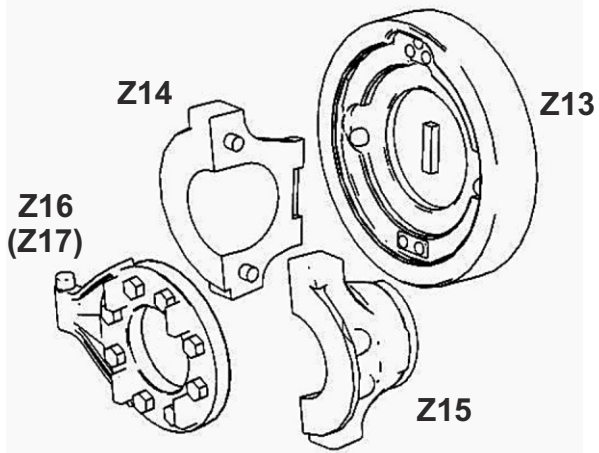

Z18 (Z19)

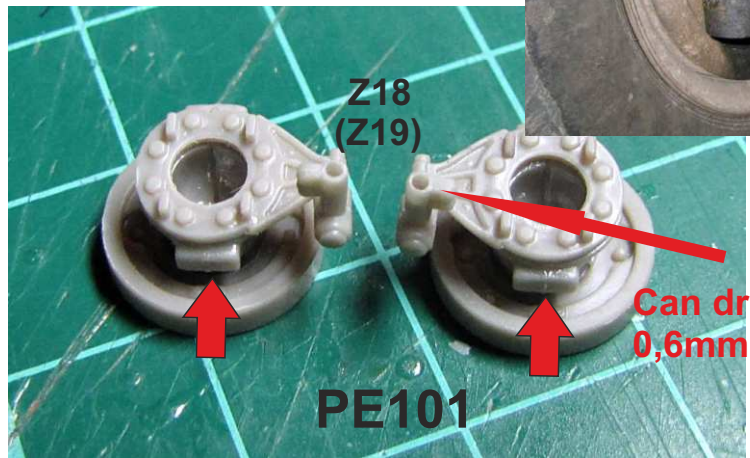

Can drill hole for 0,6mm wire

PE101

A50+A51

RE2

RE3

A50+A51

0,6mm wire

Z5

Z7

Z7

Z6

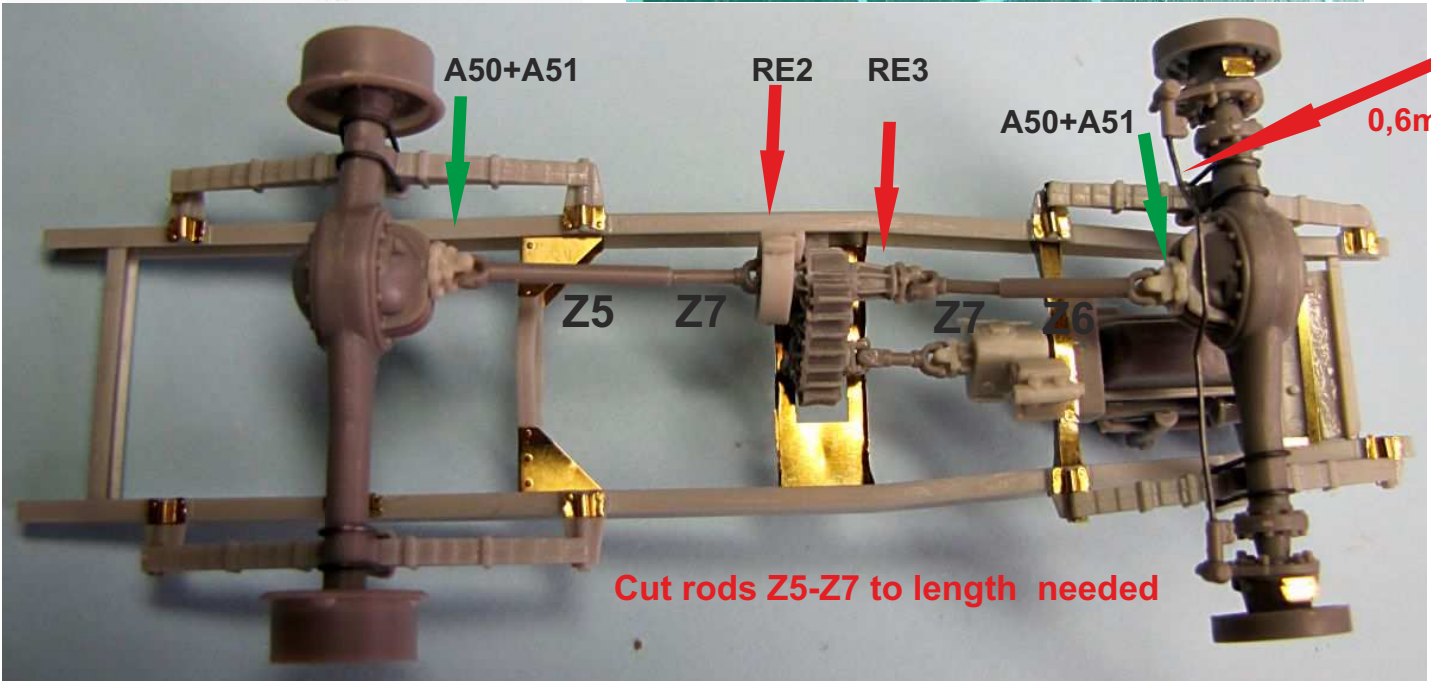

Cut rods Z5-Z7 to length needed

3

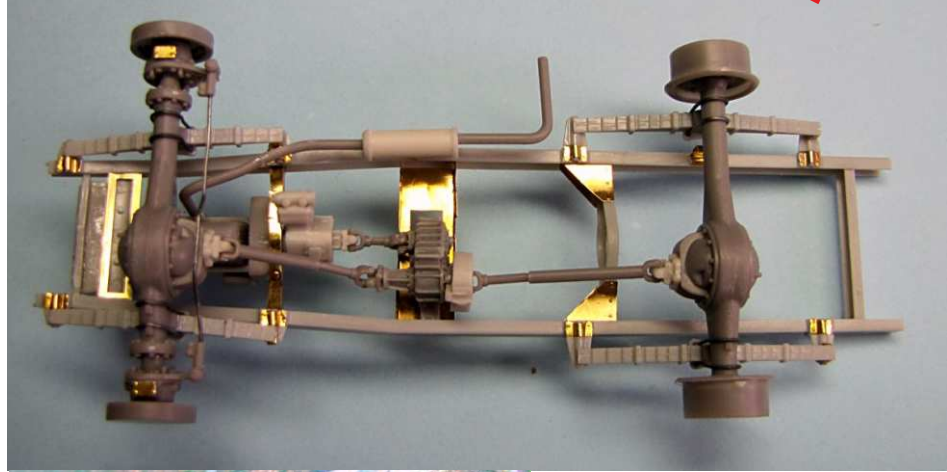
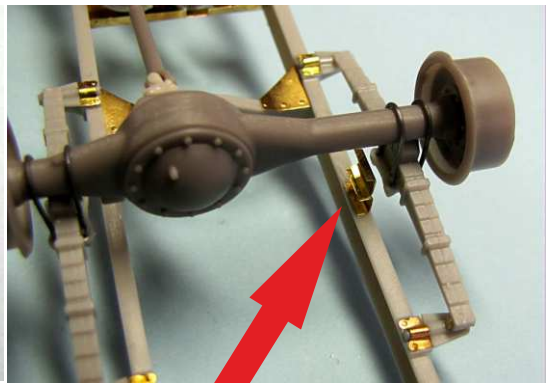
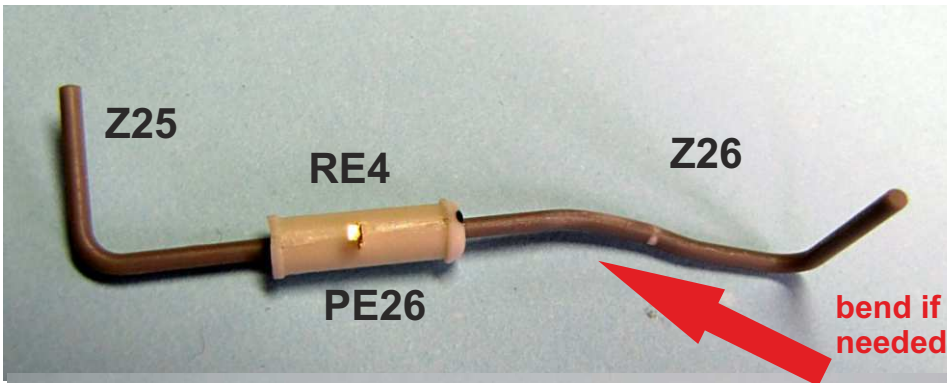

PE15+PE16

Shock absorbers in the kit are meant rather optional for additional details, PE parts are tiny a require some patience (PE9-11 can be also replaced by simple piece of 0,3mm dia wire for easier handling)

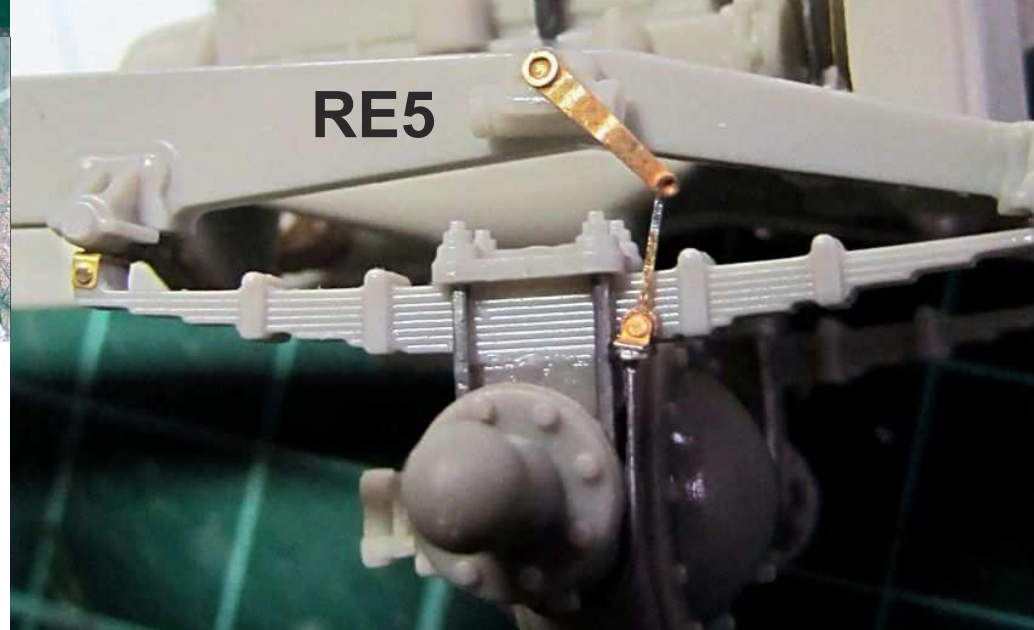
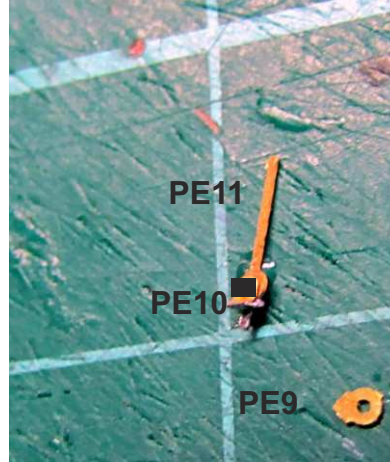

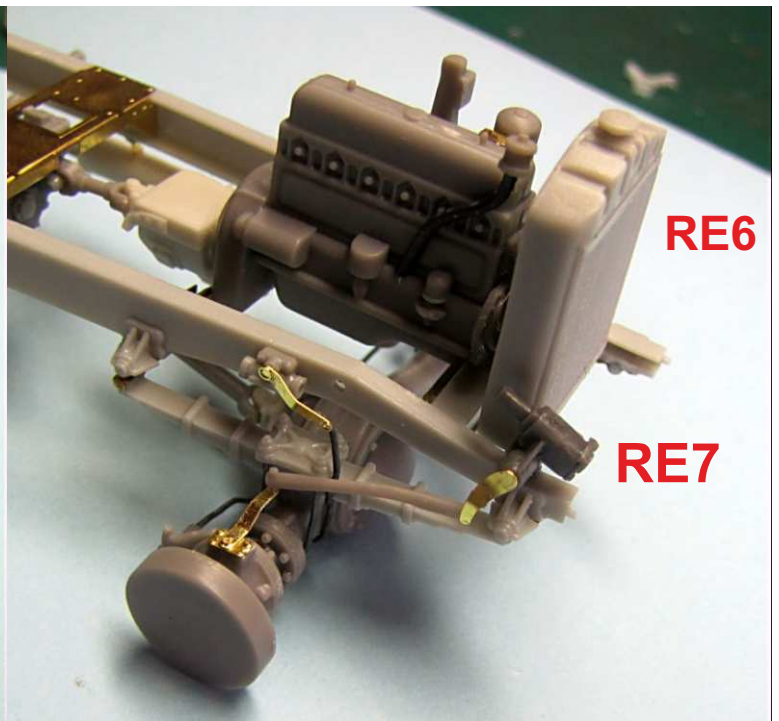
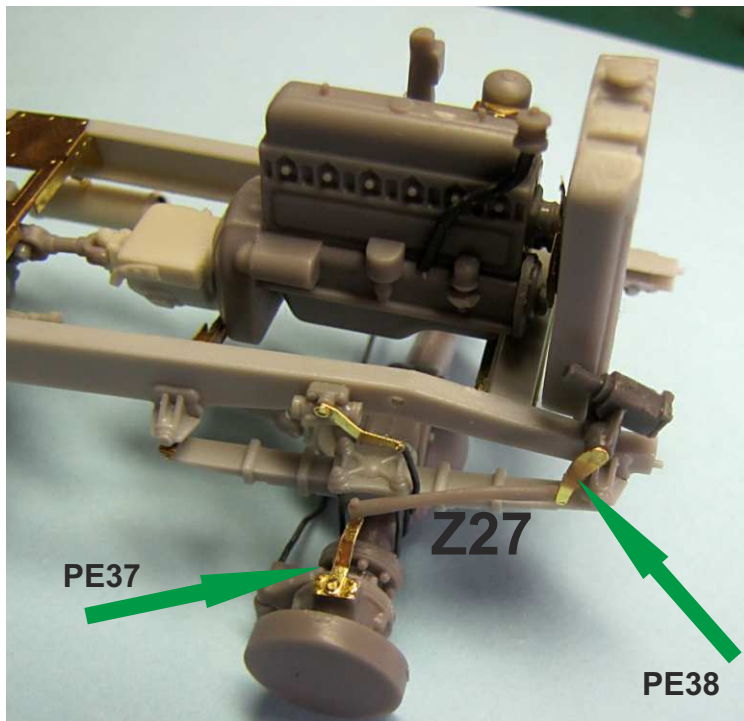

Body Assembly

If you want to go for full interior, do not assemble part A3 until you have done all inside windows subassemblies like described on following pages

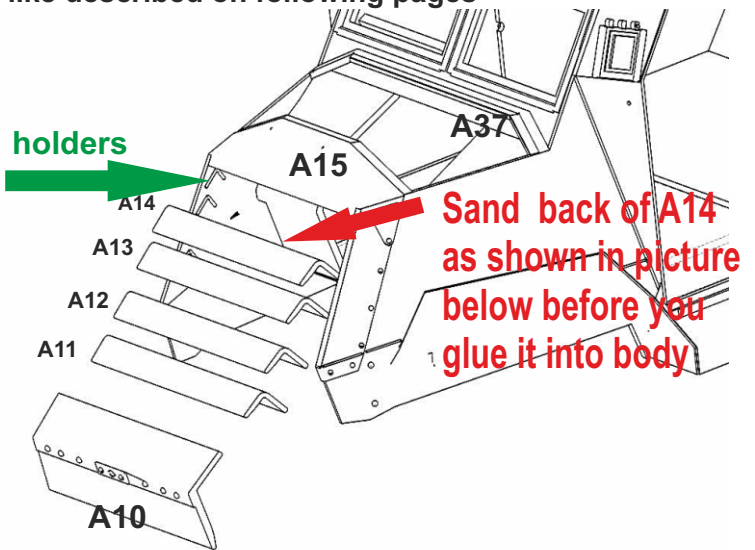
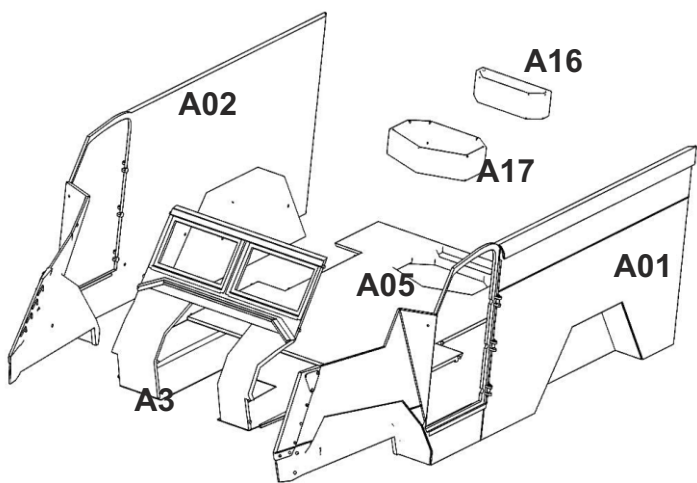

pins on floor and front into holes in body sides, you might need to adjust holes

Assemble A15 first, then A11-A14 onto holders
Assemble A10 and A37

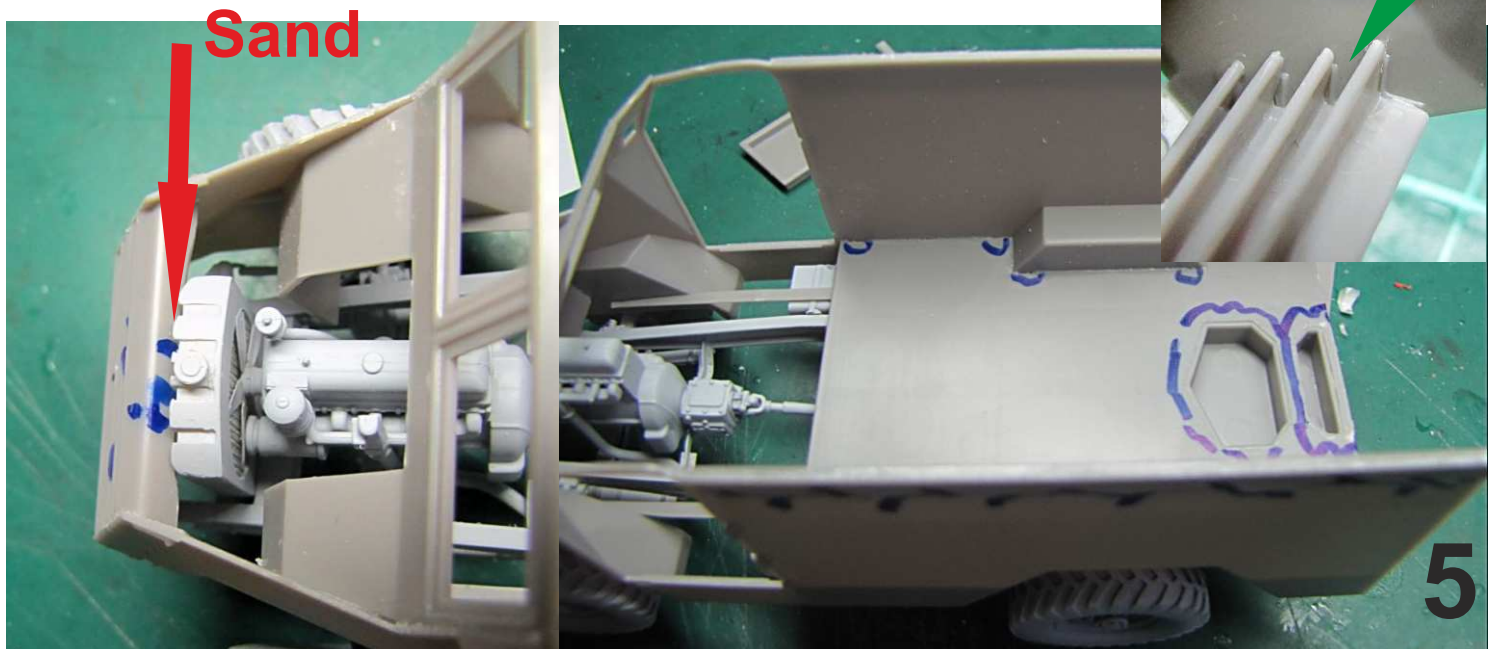

The kit offers option of closed or open front windows, but because of difference between wall thickness in real and scale, it is only possible with a little surgery. **If you want to build closed vehicle without interior details, you can leave these steps**

A48 - mind inner and outer design

glue on 2 plastic strips (supplied in bag) 0,75x1,6mm, 0,2mm thick - closed window

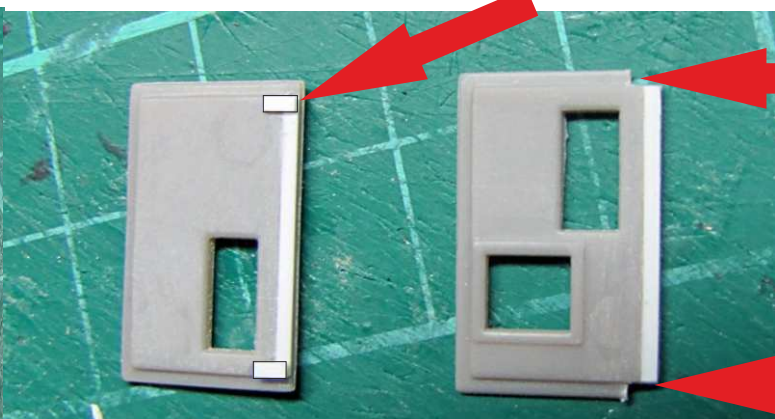

cut - sand - as shown in pictures for open window option

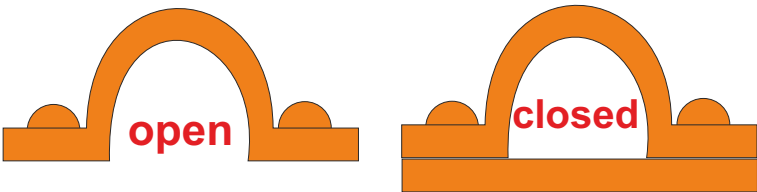
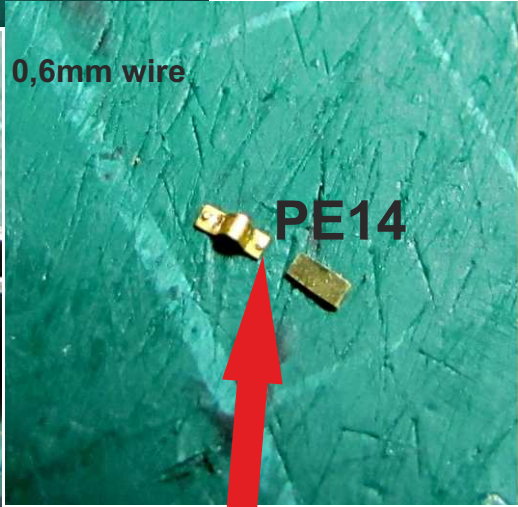

bend base of PE14 180° below to adjust its high for closed window option
cut it out like in picture and use just part with rivets to make hinges for open window option

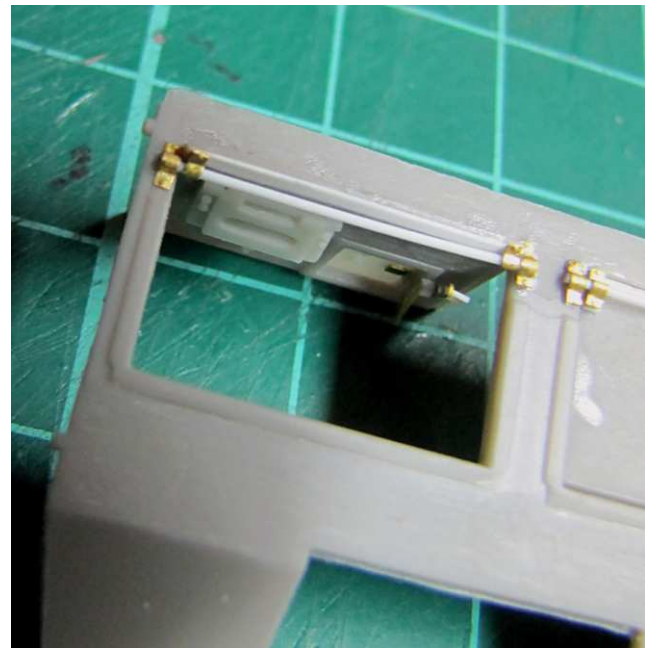

small windows assembly - for closed option use PE24, for open option use PE23
mind position of PE21, different for opened (down) and closed (up) window

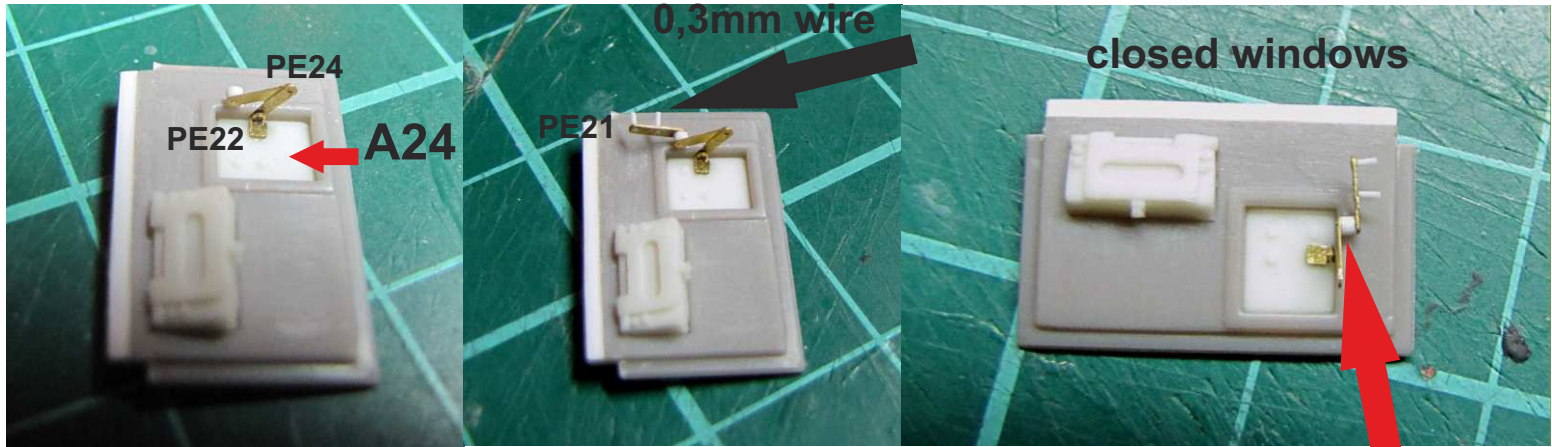

slice of plastic rod provided in the bag

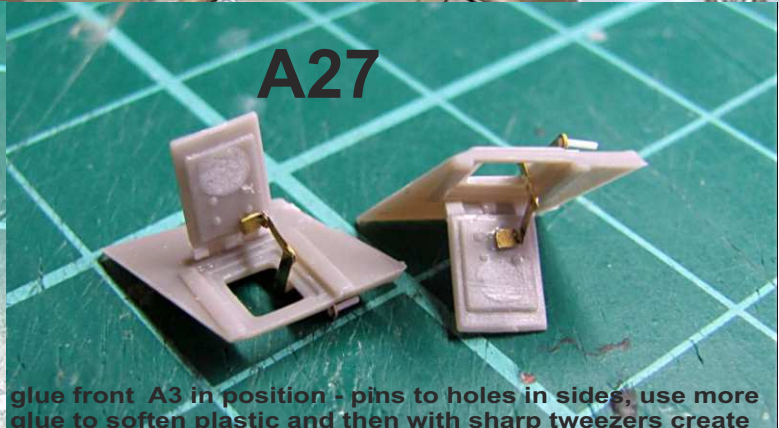

glue front A3 in position - pins to holes in sides, use more glue to soften plastic and then with sharp tweezers create in softened plastic nice welding lines. You might also prefer to glue pedals PE31 on A3 before it is glued between body sides.

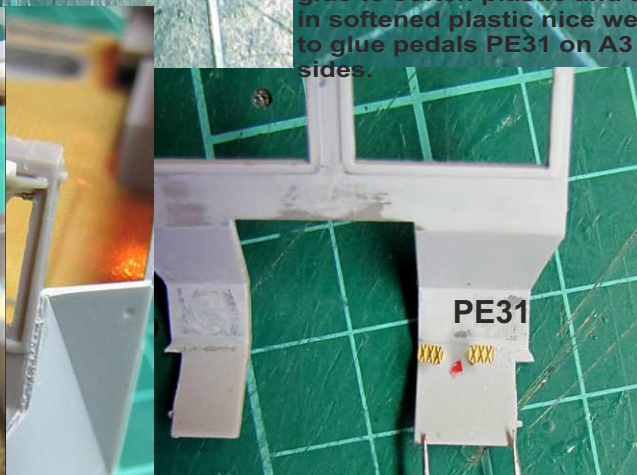
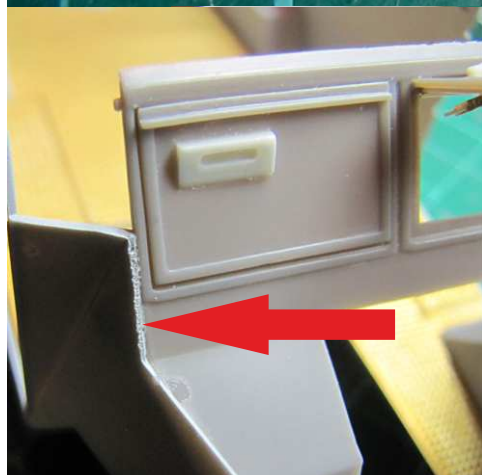

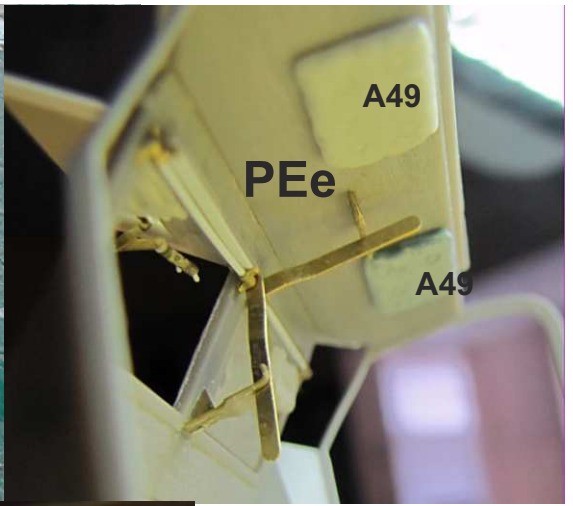

For Ambulance hard top you will need to assemble PEe and 2x A49 during dry-fit or through doors openings

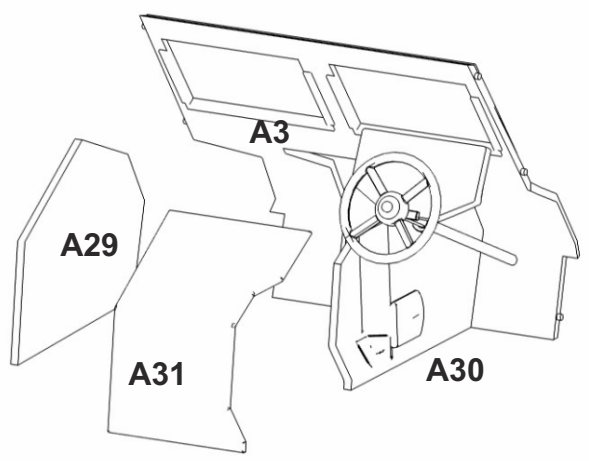
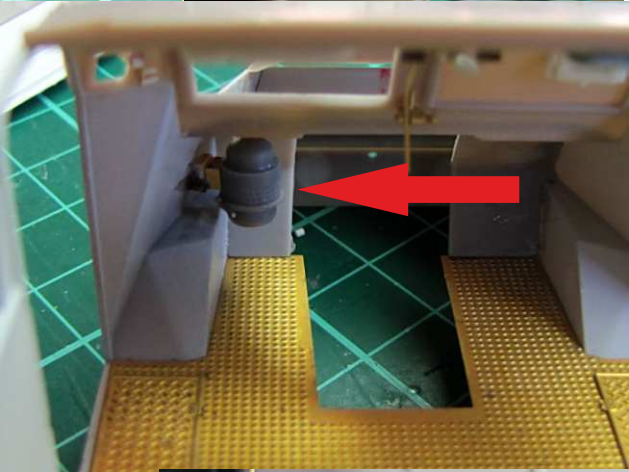
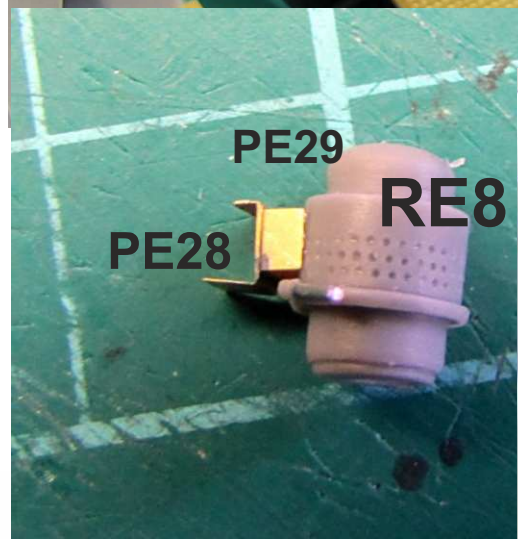

Assemble dog house and steering wheel

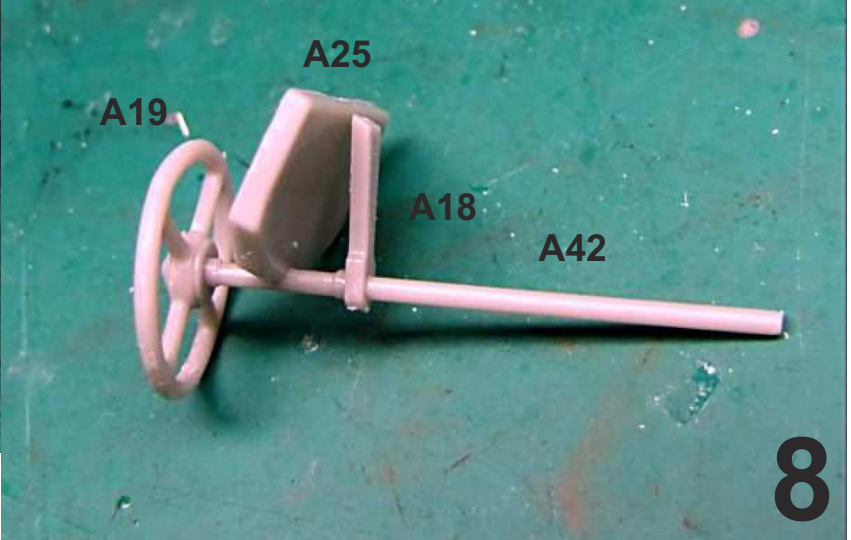

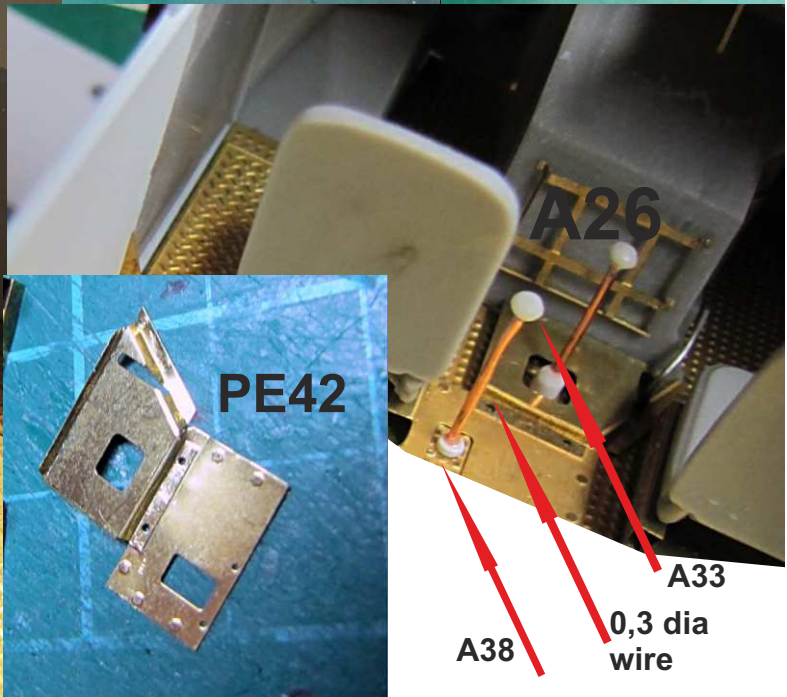
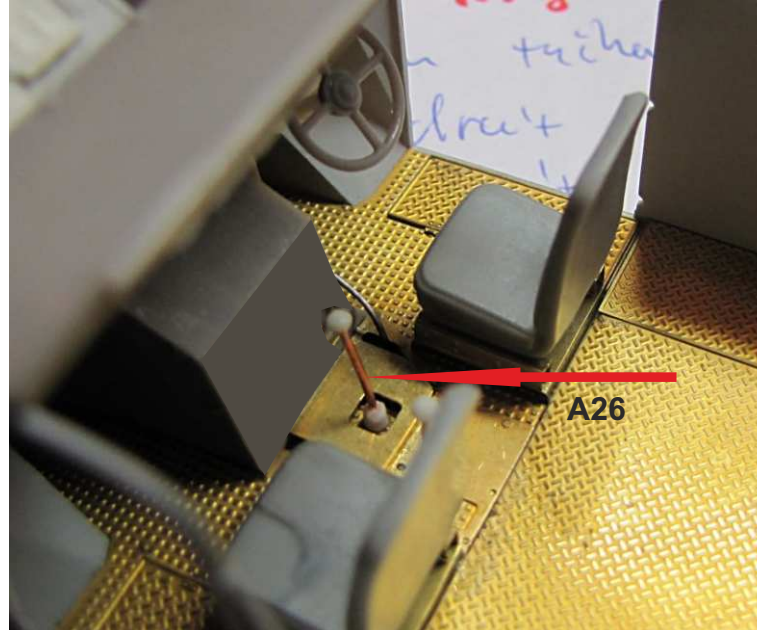
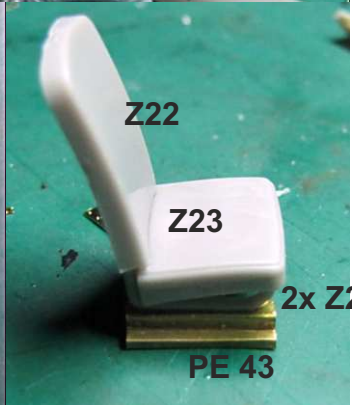
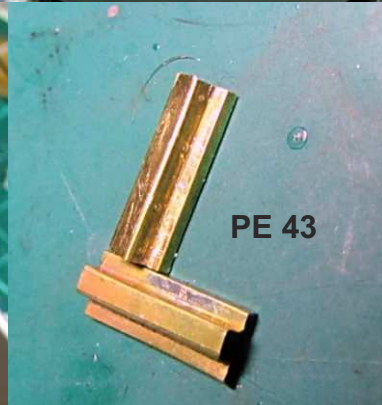
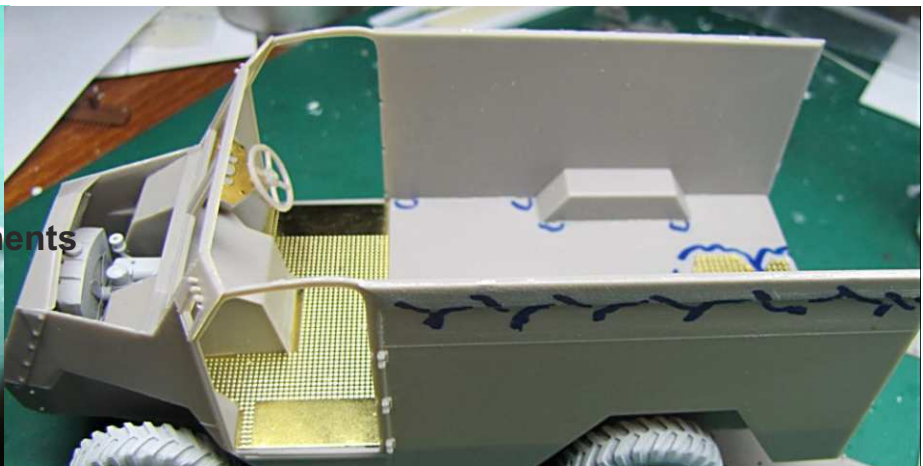
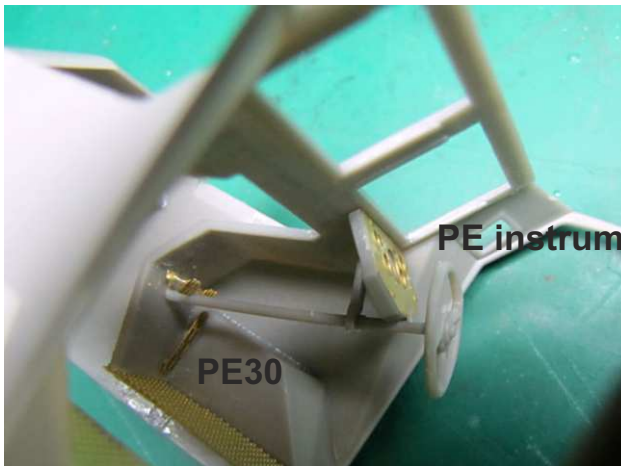

open or closed window option

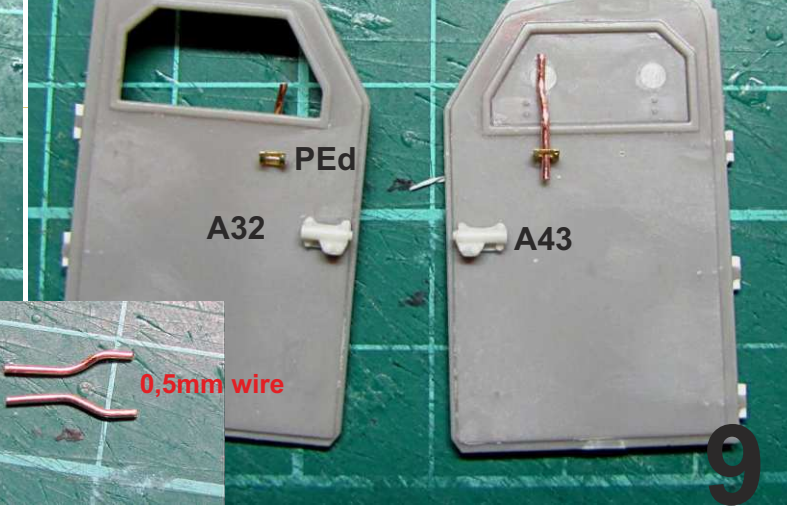
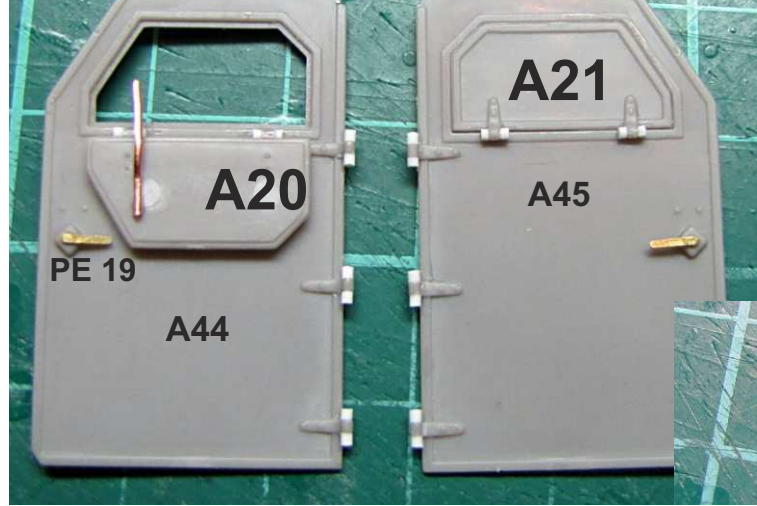



Bonnet can be assembled in any position wanted, open or closed

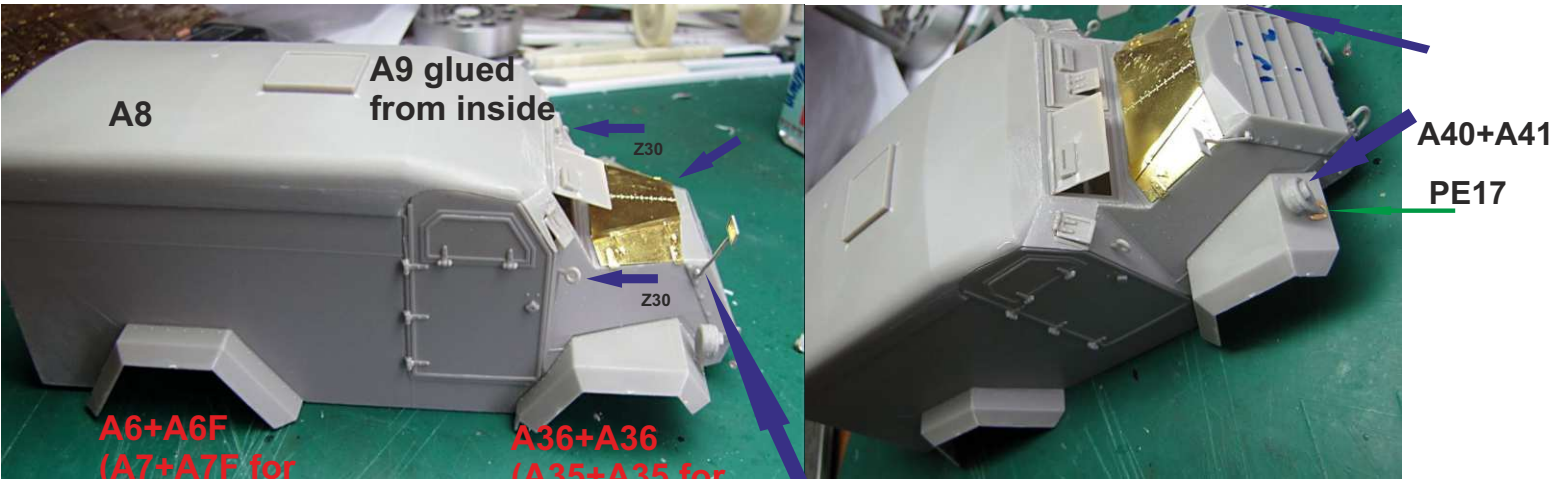

A6+A6F (A7+A7F for opposite side)

A36+A36 (A35+A35 for opposite side)

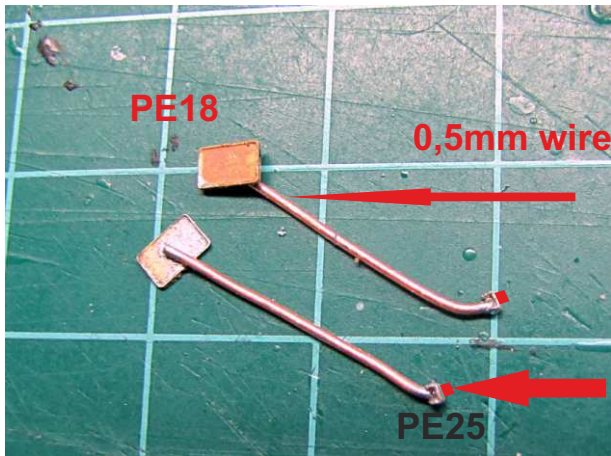

put wire through hole in PE25, leaving short end at the back, that can be glued into a hole drilled in place where mirrors are to be assembled later - your mirrors will never fall off



Plastic sheet used for flexible rear canvas - included

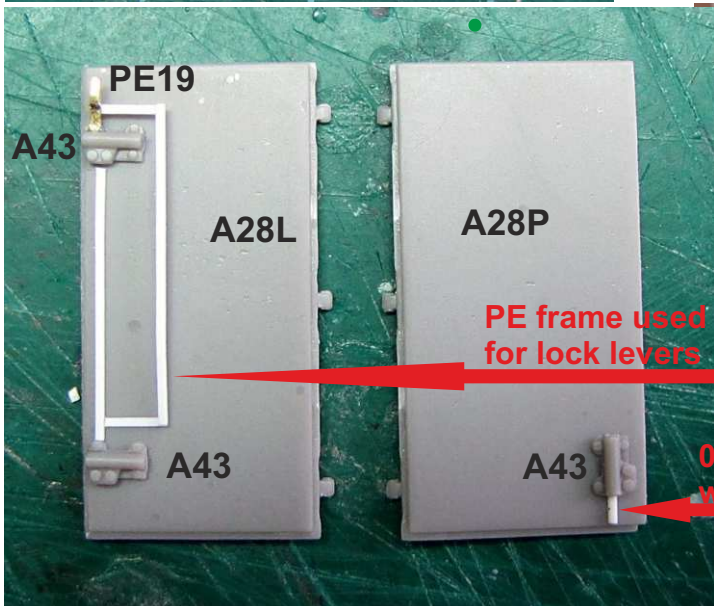

RE9+RE10



Front



Back



Assemble wheels

Front

Back

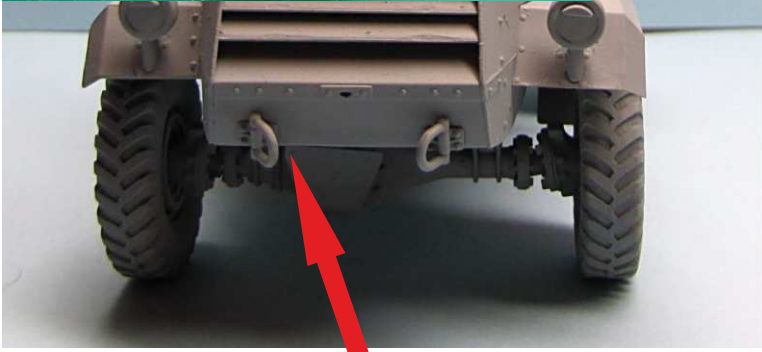

Z20+Z21



PE46



PE45



PE44

Z5822762, Ambulance, Unknown unit, France 1944.

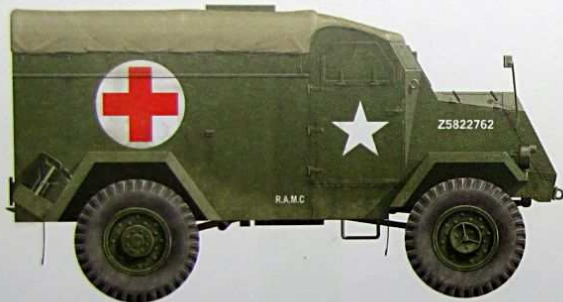

Z5822762, Ambulance, Unknown unit, France 1944.

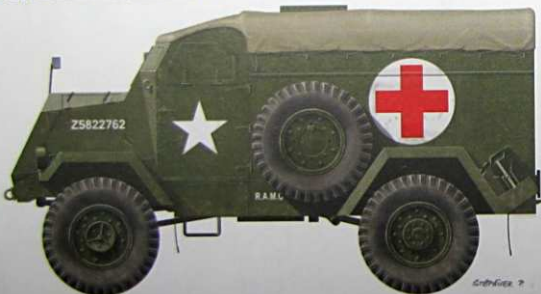

- S.C.C. No.2
Brown
- S.C.C. No.1a
Dark Brown
- S.C.C. No.15
Olive Drab

We have improved many things on our recent releases, any ejector marks will be avoided as much as possible, and most of parts are now molded in plastic without compromises on detail.

Russian Artillery Tractor Komsomoletz - full plastic kit with superb details, full engine and interior

CMP Ford F15 line fully in plastic except resin wheels, small sheet of optional PE details

CMP Chevrolet C60L GS truck fully in plastic , small sheet of optional PE details

US Diamond T truck line full plastic kits

If you have experienced missing or damaged part in your kit, contact us directly for replacement at:

Mirrormodels.contact@gmail.com

Check for updates and new kits at www.Mirror.models.com

Additional sets and accessories for our kits available at: www.Lzmodels.com

coming soon

CMP F15 Ford Truck

Precision plastic model



Cab11 and Cab12 option
2A1 and 2B1 Body option



1/35
Scale

Kit No.
35105

CMP CGT Field Artillery Tractor

Precision plastic model

Cab13



1/35
Scale

Kit No.
35122

Russian Artillery Tractor T-20 Komsomoletz

Precision plastic model



1/35
Scale

Kit No.
35200

US Diamond T969 Wrecker

Precision plastic model



1/35
Scale

Kit No.
35801

Spring 2013

Marking and painting example - used from excellent reference book

AW 09 GM C15TA Armoured Truck

from Capricorn Publications

<http://www.capub.wbs.cz/E-Shop.html>



Various stowage and handy stuff
available at www.valuegeardetails.com

