

Hurricane Mk.I

eduard

1/72 Scale Plastic Model Kit

ProfiPACK
edition



item No. 7099

Although outperformed by newer and more advanced Spitfire design, the Hawker Hurricane was the workhorse of the RAF at the early stages of the WWII and stayed in service until the end of hostilities. It saved the Great Britain at the most critical time, as it accounted for more than half of the air victories during the Battle of Britain.

The design of Hurricane was a result of initiative of the Hawker company and its chief designer Sydney Camm during the mid-30's. At the time the Air Ministry was still in biplane era with its thinking, which was represented for example by Hawker Fury widely in use with RAF. Hawker developed the P.V.3 prototype (which was in fact scaled-up Fury) to meet the Specification of Air Ministry F.7/30 from October 31, 1931. The specification called for "Zone" (i.e., short-range) fighter with four guns, powered preferably by the Rolls-Royce Goshawk engine. The only monoplane was entered by Supermarine company (the Type 224), while all others, including Hawker, entered rather conventional biplanes. The winner, Gloster Gladiator, was ordered for serial production, while Hawker P.V.3 failed to receive any interest.

Into the monoplane era

Following this setback, Sydney Camm revised the design of P.V.3 heavily and transformed it into a cantilever monoplane with retractable undercarriage. He also opted for the new and powerful Rolls-Royce PV-12 engine, which became famous under the Merlin name. All the work was a private venture at the time with Camm's design team located at Canbury Park Road in Kingston upon Thames near London. When the proposal was presented to the Air Ministry, it received quite an interest, so a new specification F.36/34 was issued by Air Ministry, calling for high speed monoplane single seater fighter, which was back-formed for the Hawker proposal.

By August 1935, the components of the prototype were completed at Hawker factory and moved from Kingston to nearby Brooklands for assembly. The K5083 prototype was then flown for the first time on November 6, 1935, with Flight Lt. George Bulman at controls. Testing at the Airplane and Armament Experimental Establishment at Martlesham Heath followed in early 1936. The RAF test pilot Sammy Wroath reported that the aircraft is easy to fly and has no apparent vices. The K5083 had a maximum speed of 253 mph (407 km/h) at sea level and reached 315 mph (507 km/h) at 16,200 ft (4,938 m), exceeding the RAF's requirements by 5 mph (8 km/h).

Betting on future

Meanwhile, although the tests were promising, Air Ministry was hanging back on serial production order, the Board of Directors at Hawker undertook bold decision to tool-up the production line to be prepared for mass production. This in fact saved the Great Britain four years later, when 1,715 Hurricanes stood up against German Luftwaffe, defending the Islands. Although outperformed at the time by Spitfire, the Supermarine's fighter was still short of supply for RAF and Hurricane squadrons represented the main force of the Fighter Command.

The order for serial production finally came in June 1936. It called for 600 aircraft, and it was not until later that month that the „Hurricane“

name was made official during the visit of his majesty King Edward VIII to Martlesham Heath. The first production airplane, L1547, flew on October 12, 1937, and the new fighter entered service in December 1937. When the WWII began in September 1939, 497 Hurricanes from the first batch were already delivered, serving with 18 squadrons. The production geared up and just a year into the war, on August 7, 1940, 2,309 of Hurricanes were delivered. Some sources state that 55 % of all the enemy planes during Battle of Britain were destroyed by Hurricane pilots, others insist on more than 60 %.

Simple but effective

The Hawker Hurricane proved significantly cheaper to build than the Supermarine Spitfire and was also simpler to maintenance and overhaul thanks to its conventional construction. The Hurricane had a light, but strong fuselage framework of high strength steel tubing covered by doped linen fabric. A girder structure covered in sheet metal made up the forward fuselage.

The early Mk.I version retained the wooden fixed-pitch propeller and fabric-covered wings of the prototype, though this would change with subsequent models. The Mk.I was powered by a Rolls-Royce Merlin Mk.II or Mk.III. The Mk.III was rated at 1,030 hp at 16,250 ft (4,953 m). Armament consisted of eight wing-mounted Browning .303 Mk II machine guns with 334 rounds of ammunition per gun.

An all-metal, stressed-skin wing of duraluminium was introduced in April 1939 and was used for later production of Mk.I and for all of the later marks of the Hurricane. The metal wings allowed the dive speed to be raised by 80 mph (130 km/h). Although of different construction, the metal and fabric wings were interchangeable and many of early Hurricanes had already their fabric wings changed for metal ones at the start of Battle of Britain. Changing the wing required just three hours of work per aircraft.

Workhorse for many fields

Aside from the Battle of Britain, the Hurricane fighters also played an important role in the defense of Malta, as well as in North Africa and other campaigns.

It could be said, Hurricane was the real workhorse of the RAF, as these fighters shot down more enemy aircraft than any other type in British inventory during WW2. More to it, aside from its fighter role, Hurricane also developed into a potent close ground support aircraft and even a tank buster, when armed with two 40mm cannons. The No. 6 Squadron was very effective with these Mk.IId Hurricanes.

Continuously upgraded throughout the war, Hurricane remained in production until July 1944. Altogether 24 variants were developed, with around 14,480 aircraft built in total. The last Hurricane (PZ865) rolled off the production line at Langley in July 1944.





Carefully read instruction sheet before assembling. When you use glue or paint, do not use near open flame and use in well ventilated room. Keep out of reach of small children. Children must not be allowed to suck any part, or pull vinyl bag over the head.



Před započítím stavby si pečlivě prostudujte stavební návod. Při používání barev a lepidel pracujte v dobře větrané místnosti. Lepidla ani barvy nepoužívejte v blízkosti otevřeného ohně. Model není určen malým dětem, mohlo by dojít k požití drobných dílů.

INSTRUCTION SIGNS * INSTR. SYMBOLS * INSTRUKTION SINNBILDEN * SYMBOLES * 記号の説明

- 
 OPTIONAL
VOLBA
- 
 BEND
OHNOUT
- 
 SAND
BROUSIT
- 
 OPEN HOLE
VYVRTAT OTVOR
- 
 SYMETRICAL ASSEMBLY
SYMETRICKÁ MONTÁŽ
- 
 REMOVE
ODŘÍZNOUT
- 
 REVERSE SIDE
OTOČIT
- 
 APPLY EDUARD MASK
AND PAINT
POUŽIT EDUARD MASK
NABARVIT

PARTS * DÍLY * TEILE * PIĘCES * 部品

PLASTIC PARTS

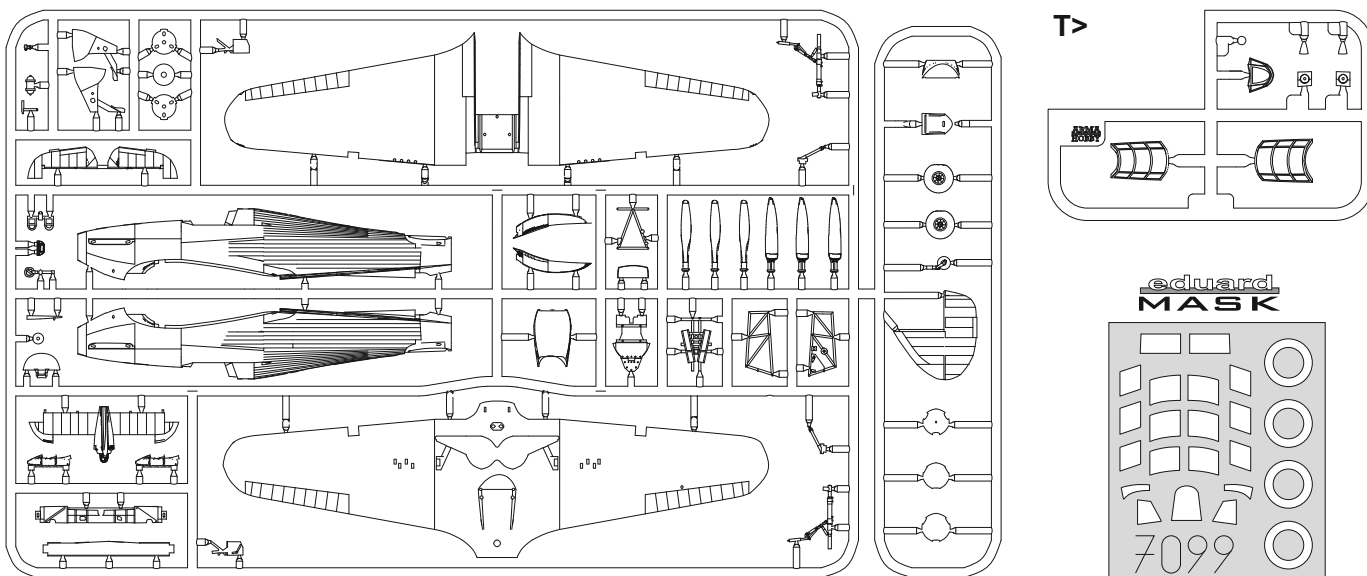

PE - PHOTO ETCHED DETAIL PARTS

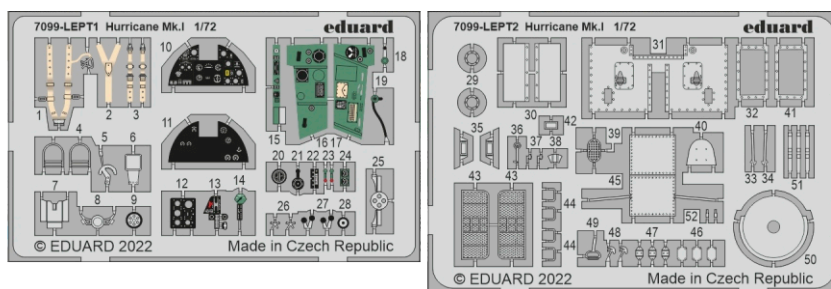

FILM

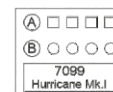

-Parts not for use. -Teile werden nicht verwendet. -Pièces à ne pas utiliser. -Tyto díly nepoužívejte při stavbě. - 使用しない部品

COLOURS * BARVY * FARBEN * PEINTURE * 色

GSI Creos (GUNZE)		MISSION MODELS	
AQUEOUS	Mr.COLOR	PAINTS	
H4	C4	MMP-007	YELLOW
H8	C8		SILVER
H11	C62	MMP-001	FLAT WHITE
H12	C33	MMP-047	FLAT BLACK
H13	C3	MMP-003	FLAT RED
H71	C21	MMP-076	MIDDLE STONE
H72	C369	MMP-078	DARK EARTH
H74	C368	MMP-080	SKY
H77	C137	MMP-040	TIRE BLACK
H90	C47		CLEAR RED

GSI Creos (GUNZE)		MISSION MODELS	
AQUEOUS	Mr.COLOR	PAINTS	
H94	C138		CLEAR GREEN
H324	C324		LIGHT GRAY
H327	C327	MMP-101	RED
H328	C328		BLUE
H330	C361	MMP-077	DARK GREEN
	C364	MMP-079	AIRCRAFT GRAY-GREEN
Mr.METAL COLOR		METALLICS	
	MC214	MMM-001	DARK IRON
Mr.COLOR SUPER METALLIC		METALLICS	
	SM201	MMC-001	SUPER FINE SILVER

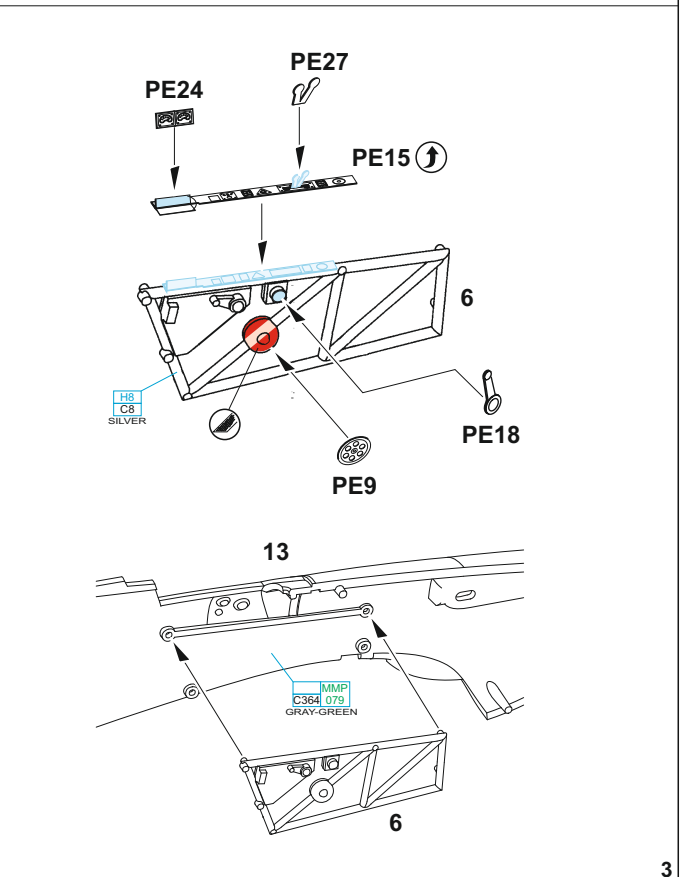
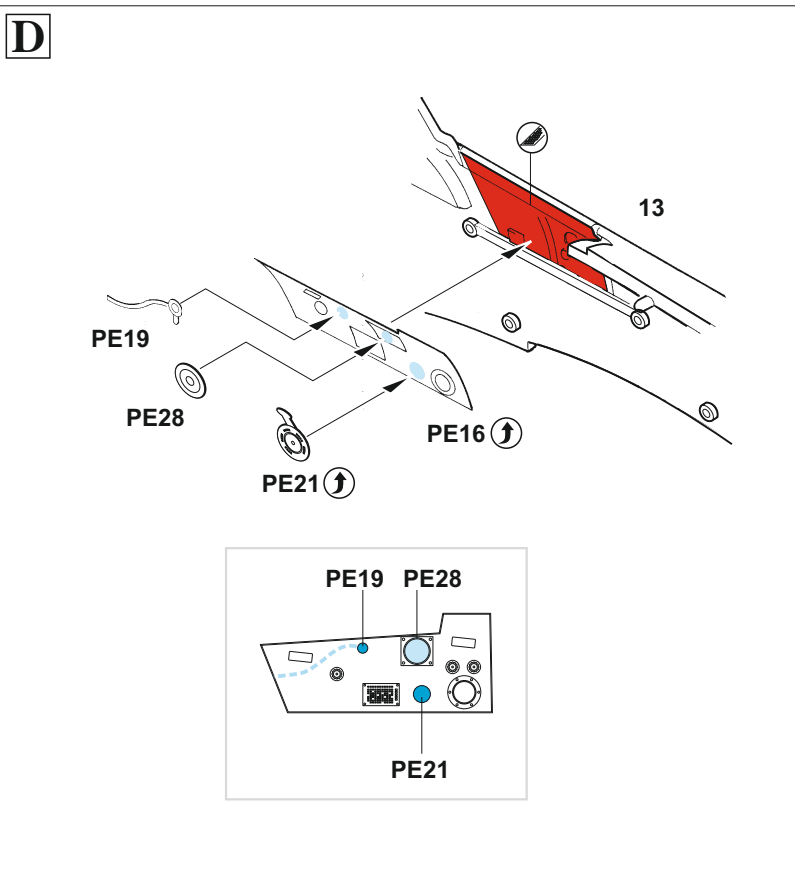
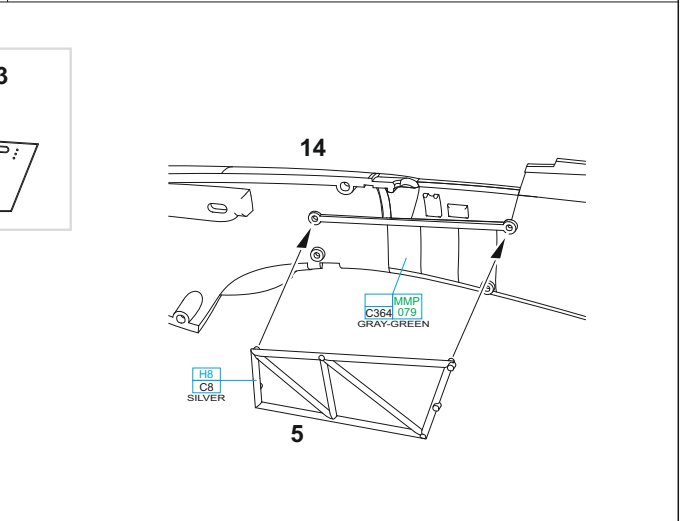
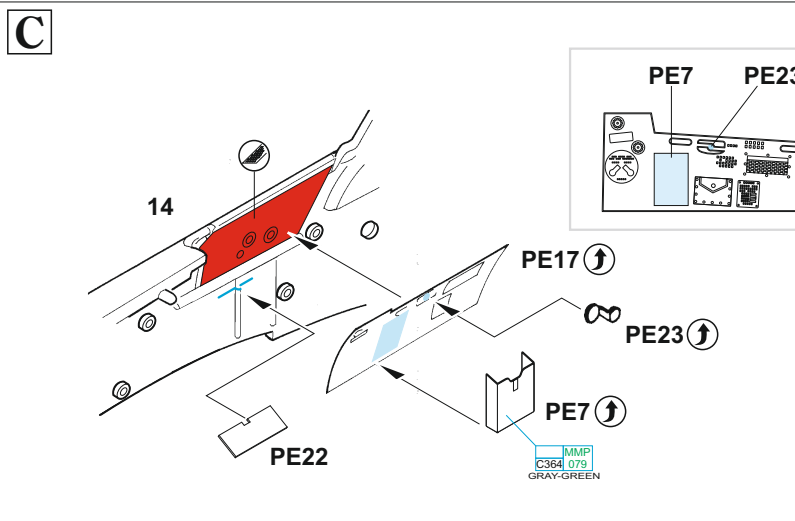
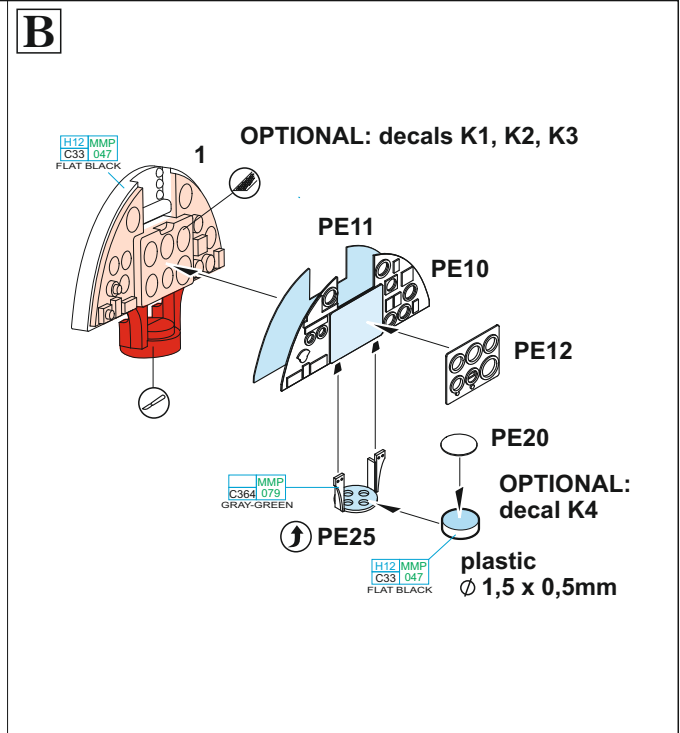
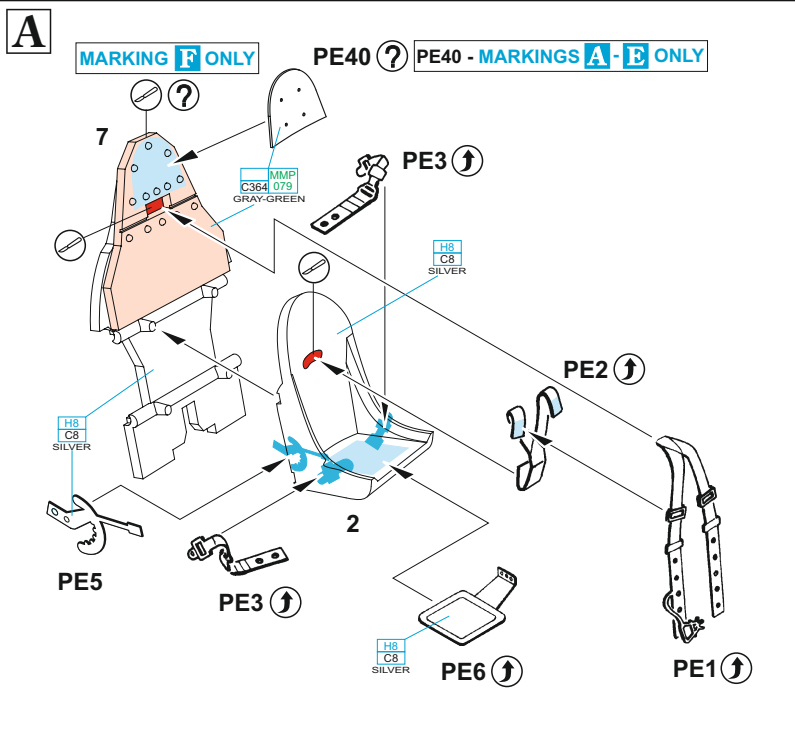

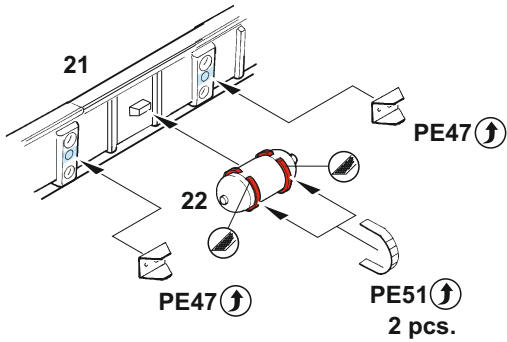
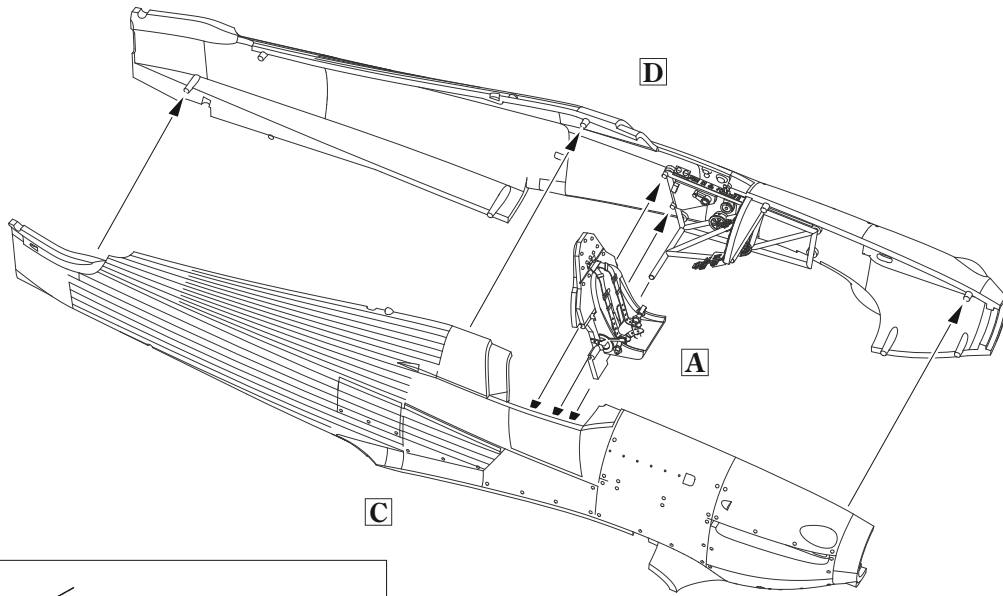
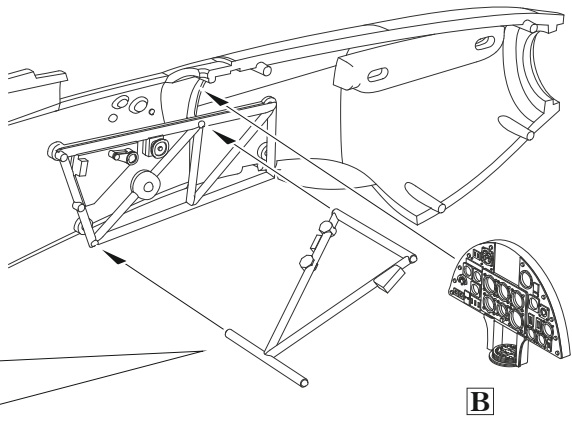
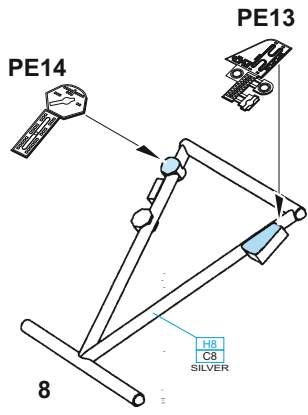

HOW TO MAKE THE RELIEF
ON OPPOSITE - REVERSE -
OF THE PLATE



ball pen

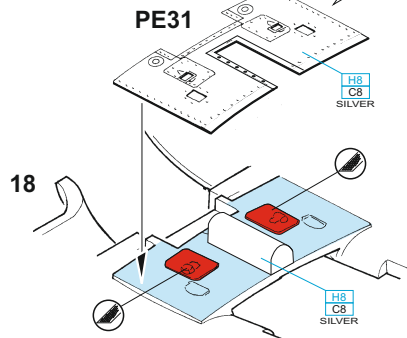
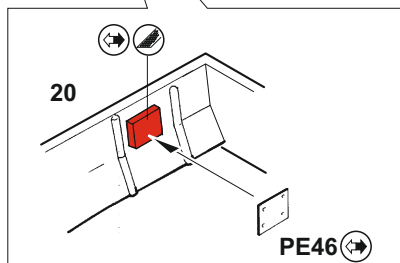
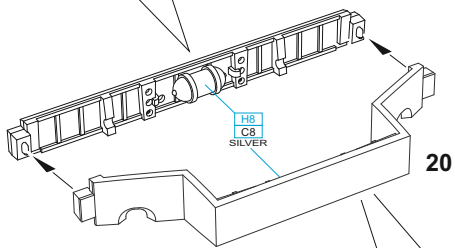
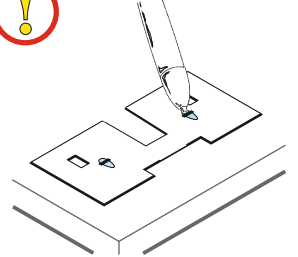

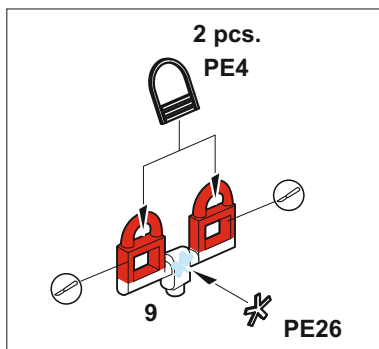
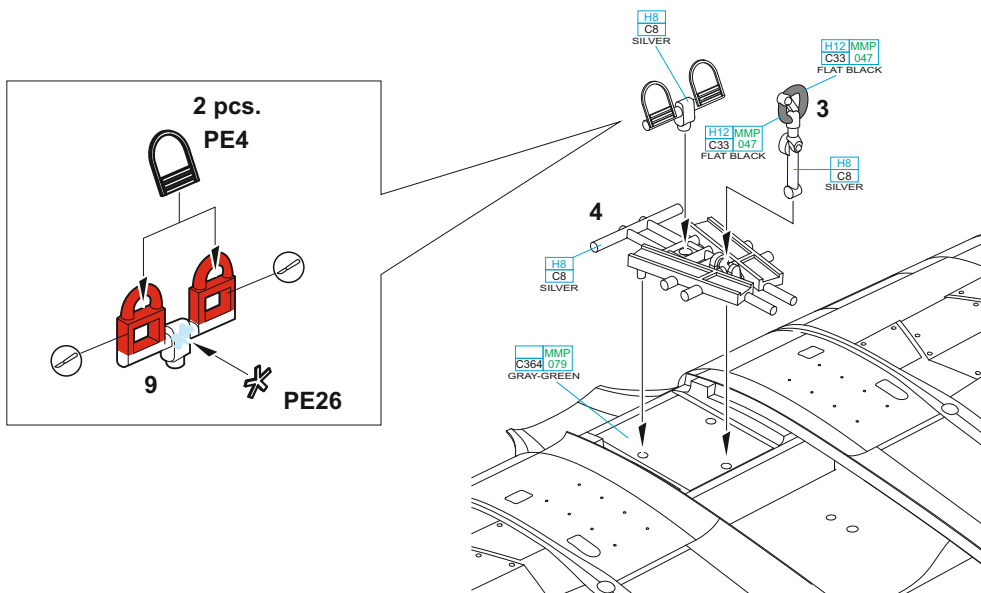
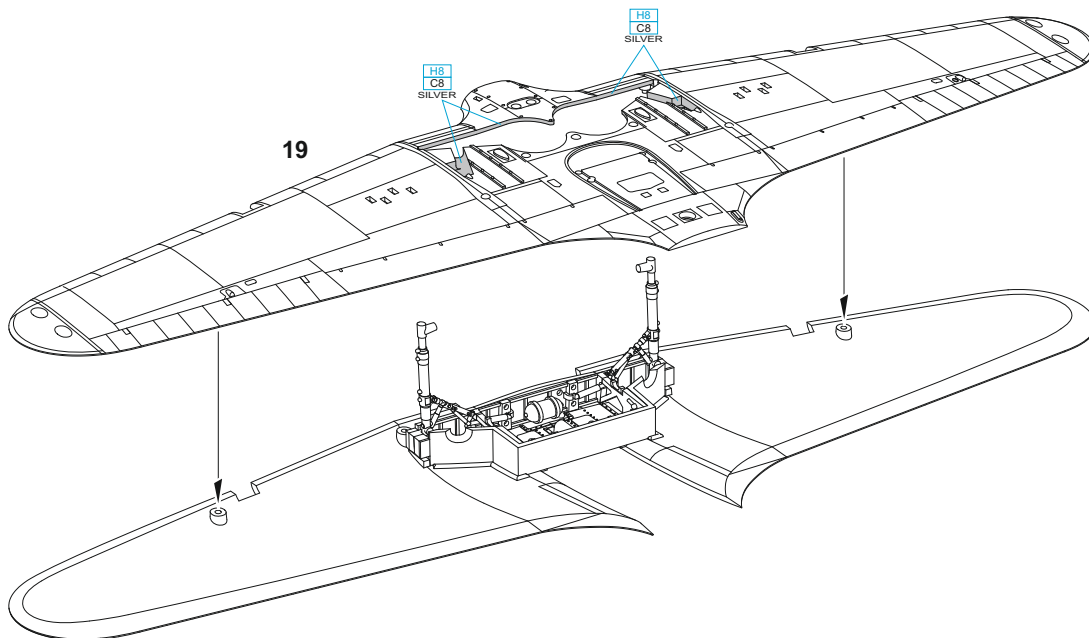
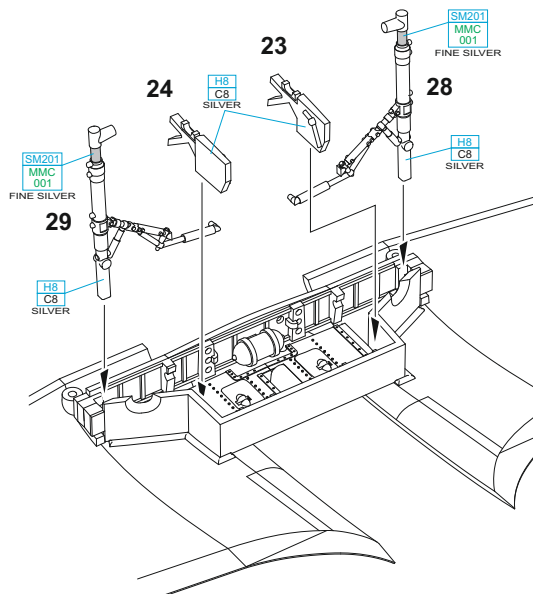
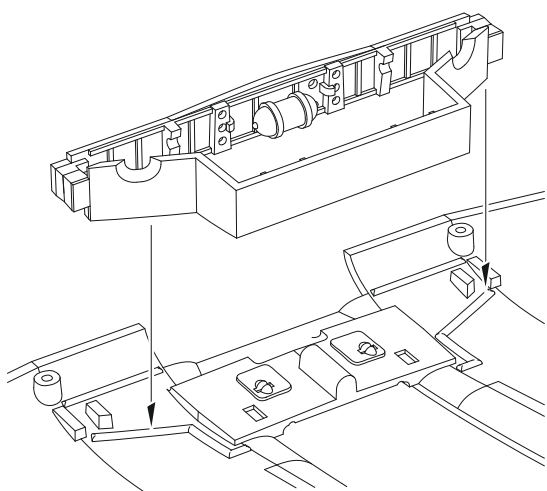

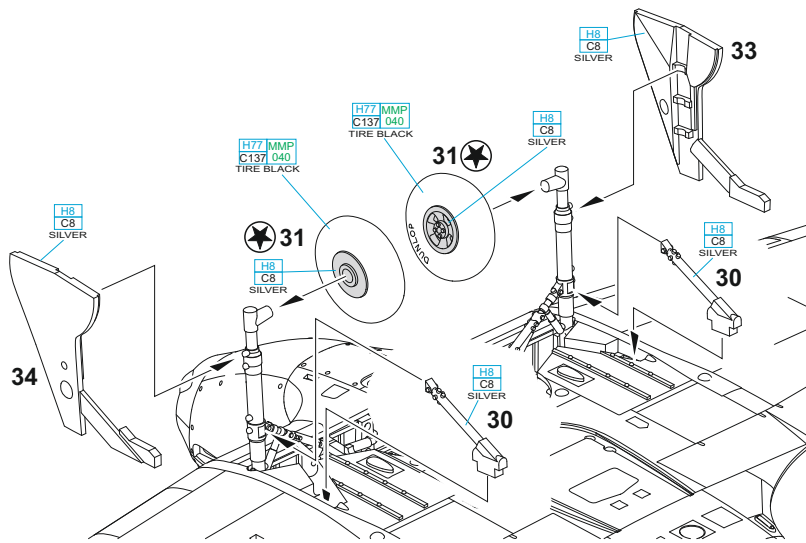
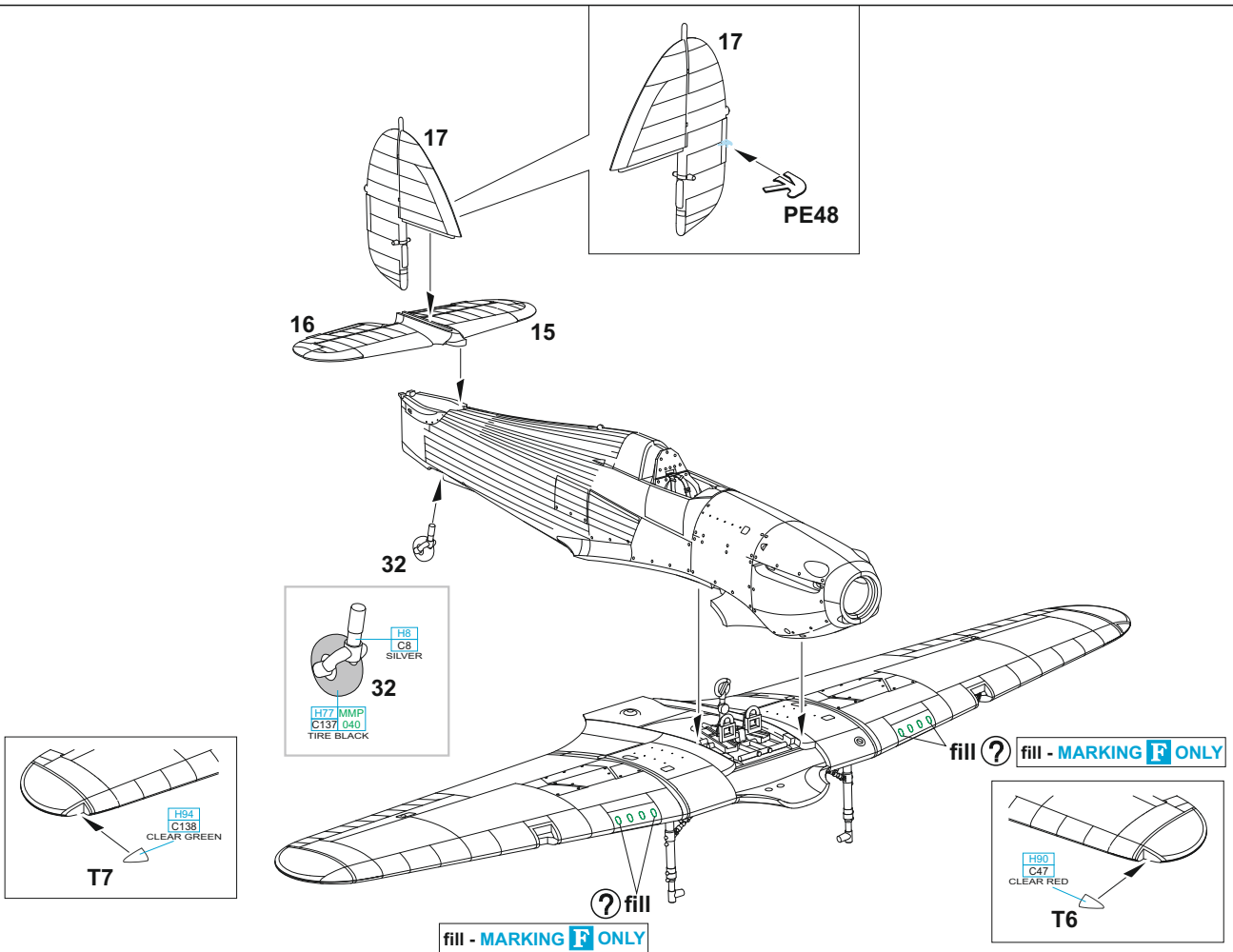

E

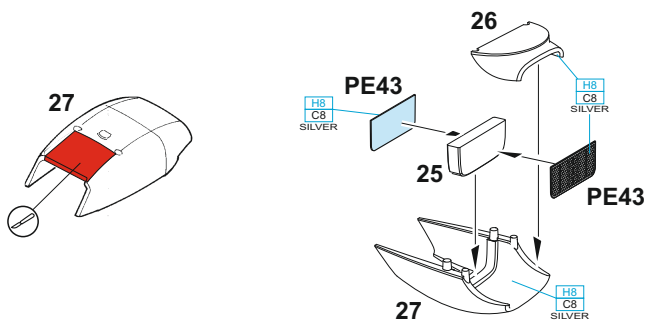

F

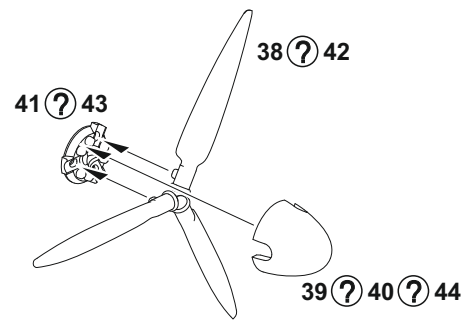

38, 39, 41 - MARKINGS **A, B, C, E**

38, 40, 41 - MARKING **F**

42, 43, 44 - MARKING **D**

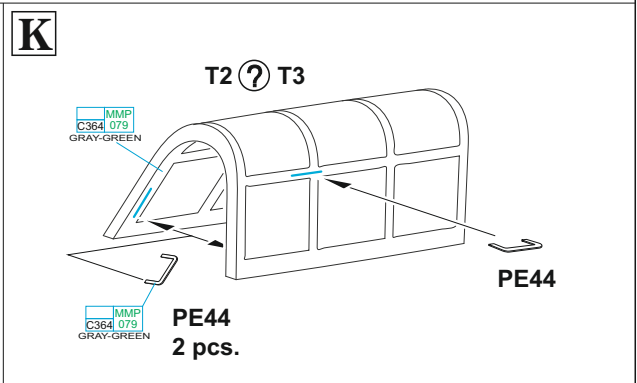
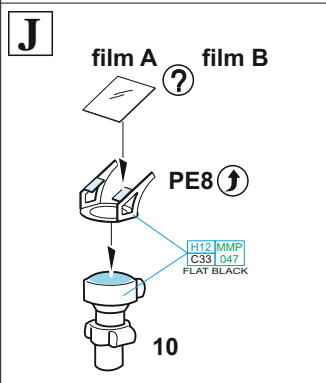
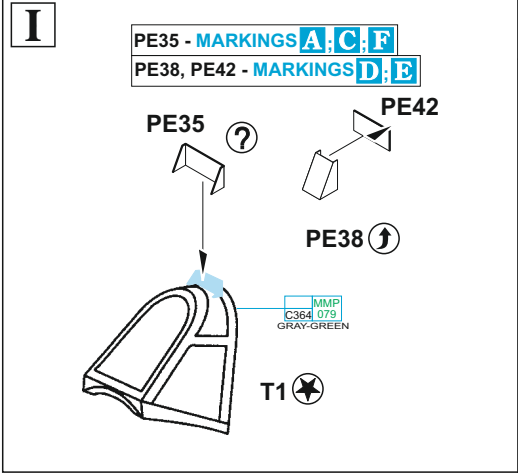
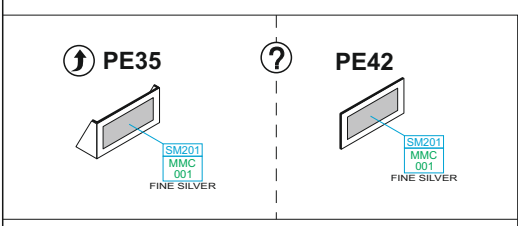
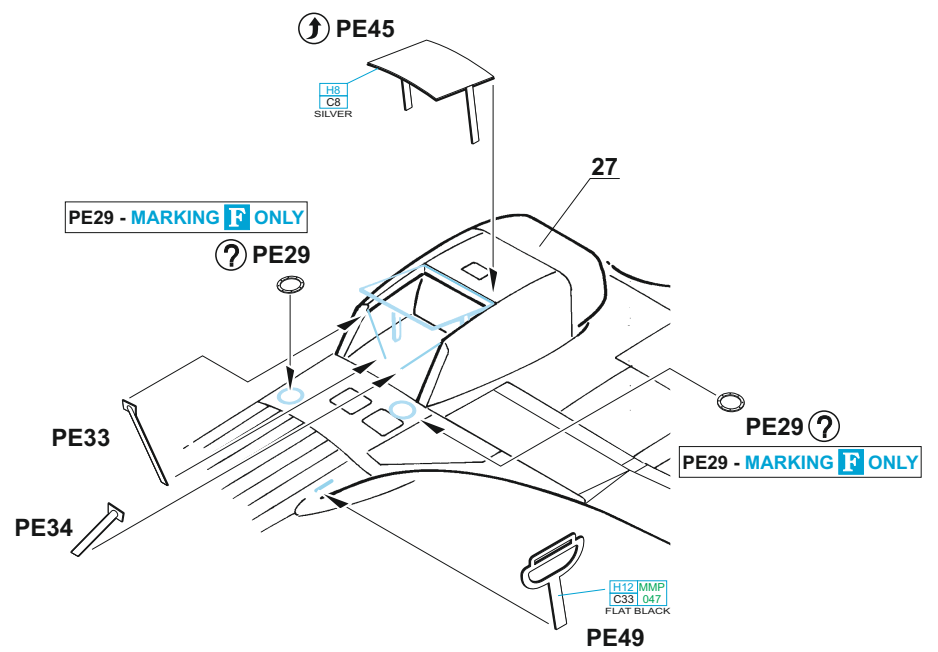
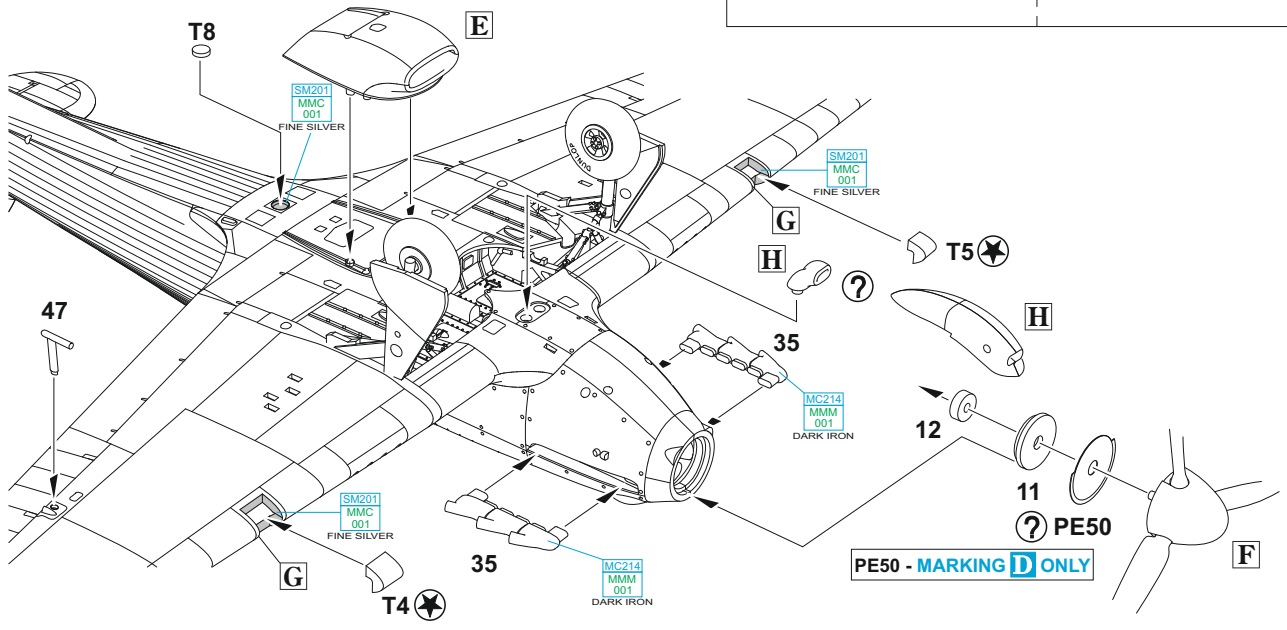
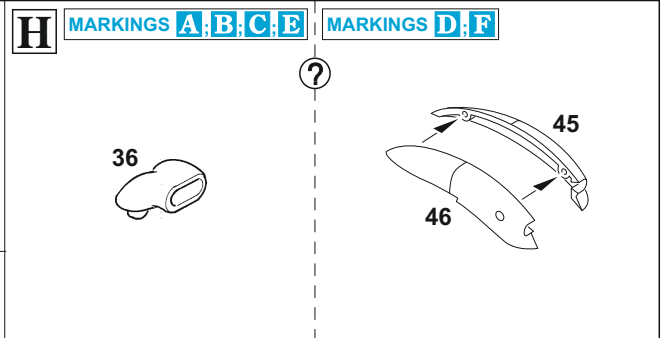
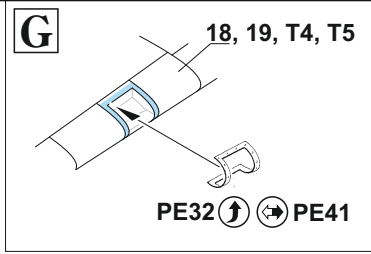

L ? MARKINGS **B:C:D:E**

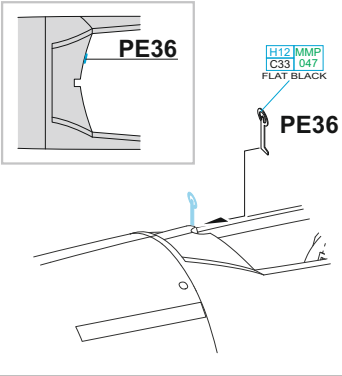

CANOPY CLOSED

CANOPY OPEN

PE52 - MARKINGS **B:C:D:E** ? PE52

H12 MMP C33 047 FLAT BLACK

37 - MARKINGS **A-E** ONLY

37 ?

MARKING **A** ONLY

PE30 ? ? ?

PE30 - MARKING **D** ONLY

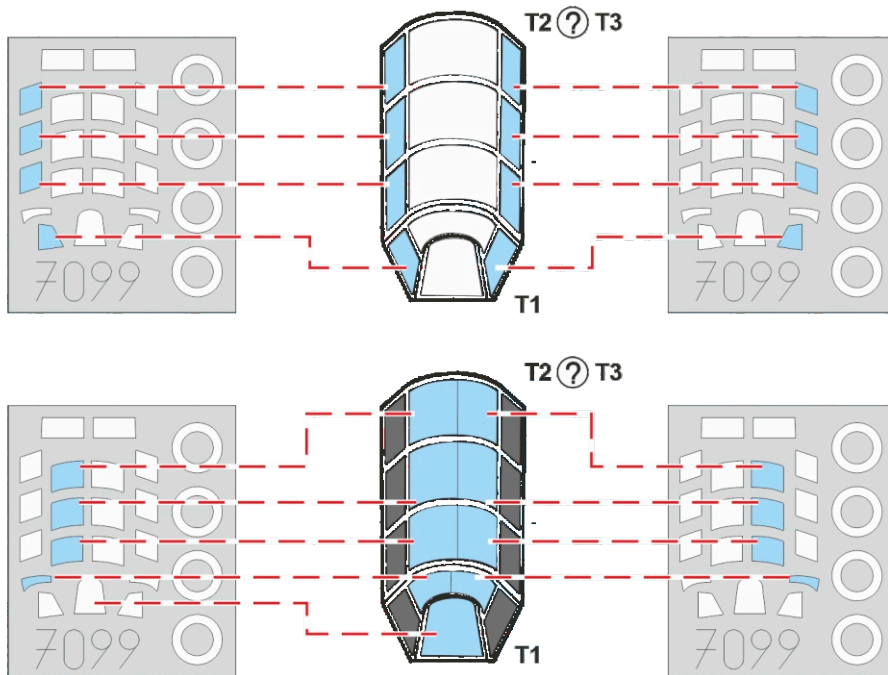
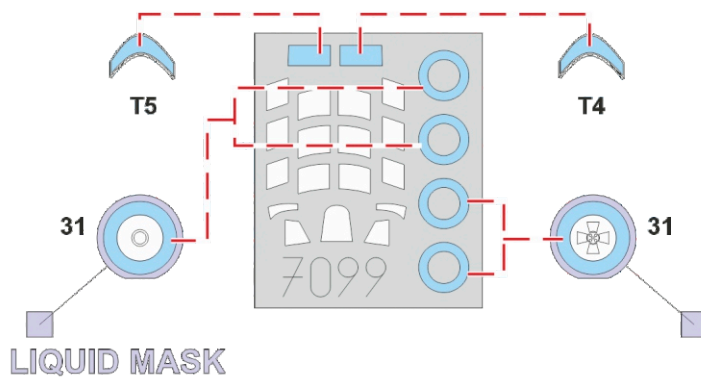

A P3878, F/O Harold A. C. Bird-Wilson, No. 17 Squadron, RAF Debden, Great Britain, July 1940

Harold Bird-Wilson, a native of Prestatyn, Wales, joined the RAF on November 30, 1937. After training he was transferred to No. 17 Squadron in August 1938, the unit flying with Gloster Gauntlets at the time. The unit was rearmed with Hurricanes in June 1939, and ten weeks later "Birdy" Bird-Wilson was badly injured in a flying accident. After his recovery, he rejoined the unit and took part with it in the Battle of France and subsequently in the Battle of Britain. He scored eight confirmed kills during that period. On September 24, 1940, "Birdy" was shot down by Adolf Galland, for whom it was his 40th kill. "Birdy" later became commander of the Spitfire equipped No. 122 Wing and later he led the Perranporth/Harrowbeer Wing flying Mustangs. He shot down a total of nine aircraft (3 solo and 6 shared) and also recorded three probable kills and three damaged. During his military career he received the high military awards including CBE, DSO, DFC & Bar and AFC & Bar. Retired on June 1, 1974, with the rank of Air Vice Marshal. The Hurricane P3878 sported camouflage of Dark Green, Dark Earth and Sky. The right side of the fuselage below the cockpit was marked with three kills scored during the Battle of France in May 1940.

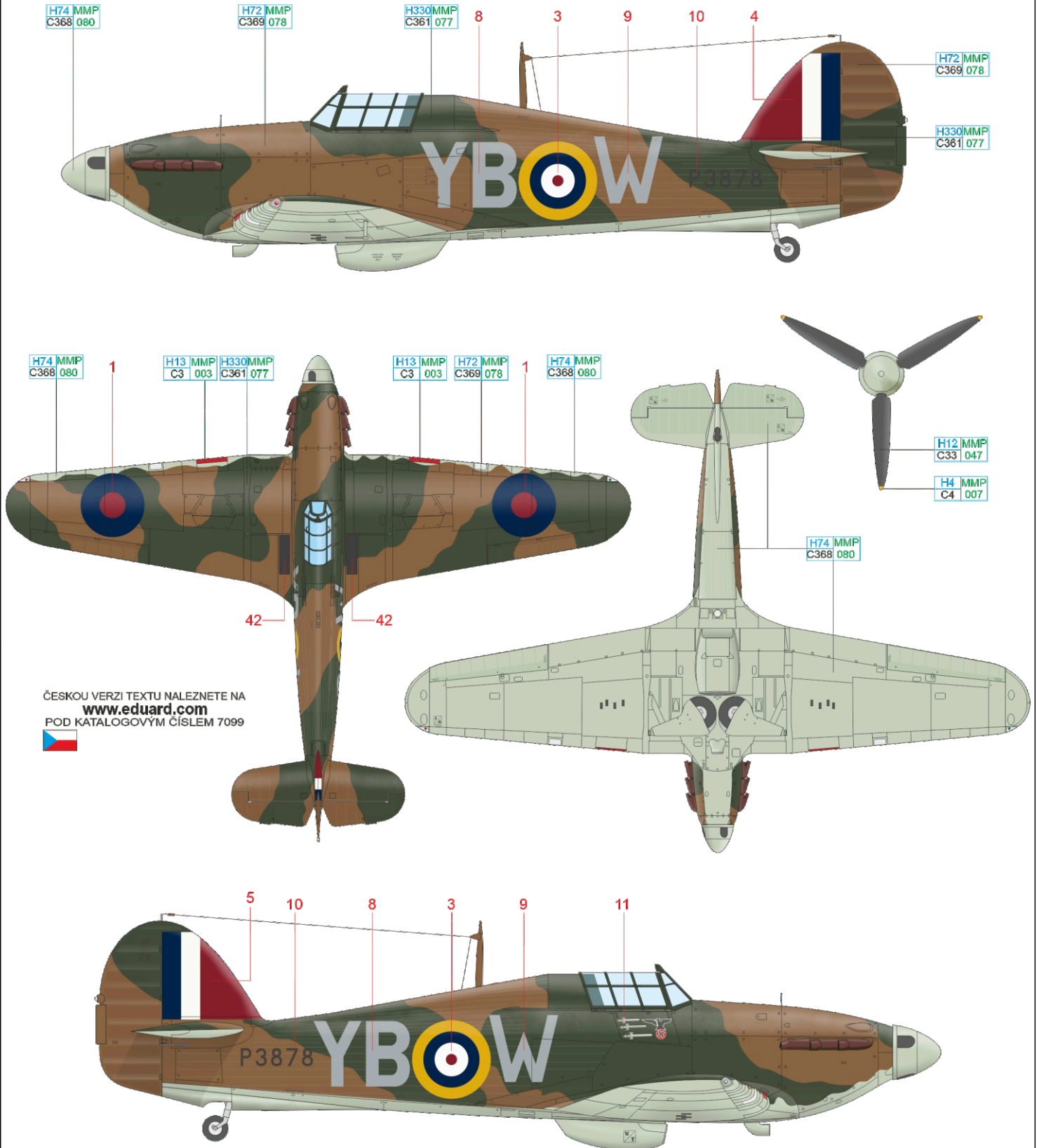

ČESKOU VERZI TEXTU NALEZNETE NA
www.eduard.com
 POD KATALOGOVÝM ČÍSLEM 7099



DARK EARTH	H72 MMP C369 078	DARK GREEN	H330 MMP C361 077	SKY	H74 MMP C368 080	RED	H13 MMP C3 003	YELLOW	H4 MMP C4 007	FLAT BLACK	H12 MMP C33 047
------------	------------------	------------	-------------------	-----	------------------	-----	----------------	--------	---------------	------------	-----------------

B P3143, No. 310 (Czechoslovak) Squadron, RAF Duxford, Cambridgeshire, Great Britain, September 1940

The Hawker Hurricane Mk.I, serial number P3143 was codenamed NN-D and served with No. 310 (Czechoslovak) Squadron from July 24, 1940, until October 16 of the same year, when it was destroyed by an engine fire during a training flight near Ely. Its pilot, Sgt Jan Chalupa, bailed out but died. It was the unit's most successful aircraft of the Battle of Britain. Pilots F/Lt Gordon Leonard Sinclair, Sgt Bohumil Fürst, Sgt Eduard Prchal and P/O Stanislav Fejfar scored a total of six confirmed kills flying it (two each of Bf 110 and Do 17 plus one each of Bf 109 and He 111). P3143 wore the "A" pattern camouflage consisting of standard colors, i.e., Dark Green, Dark Earth and Sky. In its appearance from mid-September, it sported four kill marks under the cockpit.

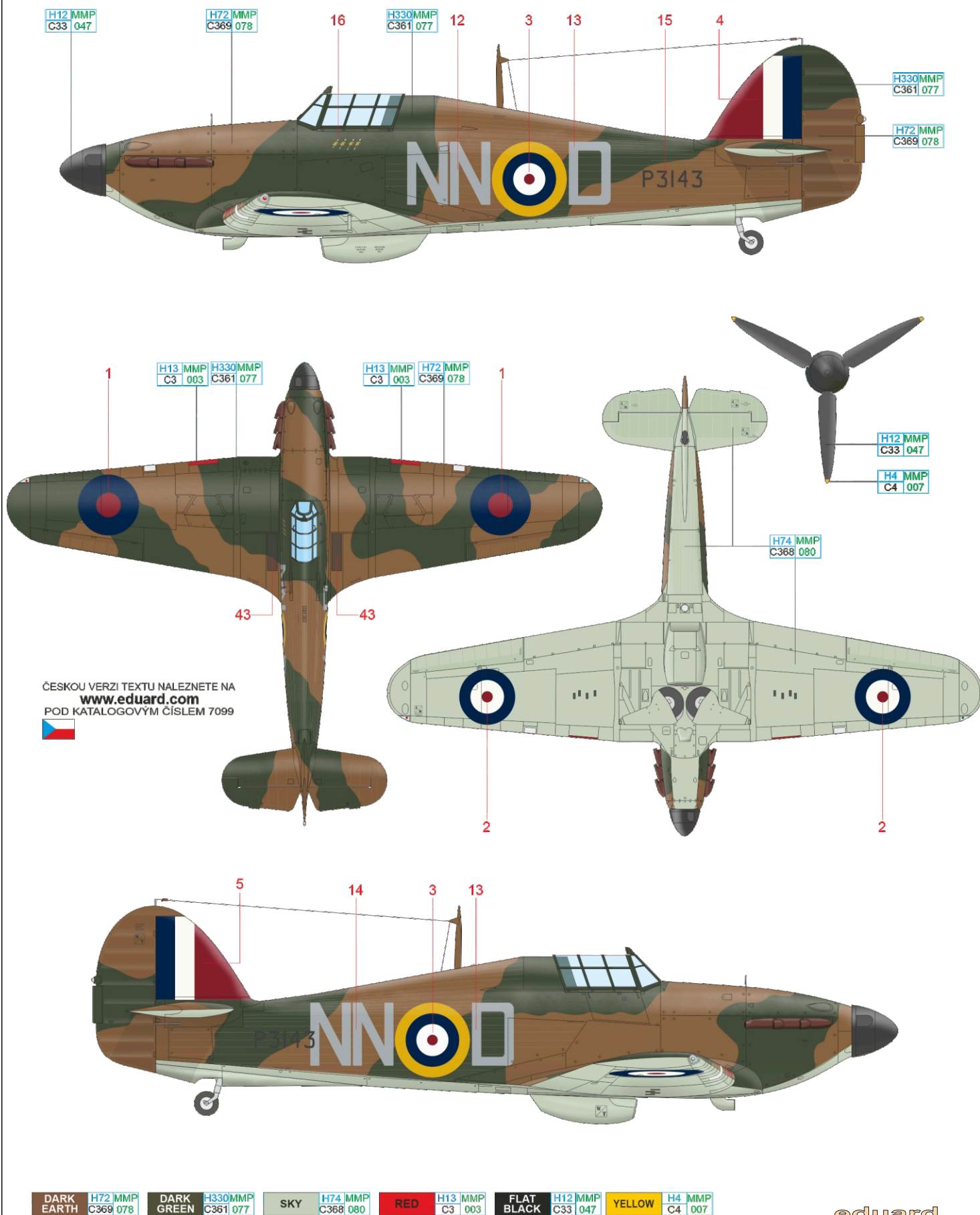

C P3675, F/Lt Michael L. Robinson, No. 601 Squadron, RAF Tangmere, West Sussex, Great Britain, September 1940

During September days of the Battle of Britain, "Mike" Robinson shot down one Bf 109E and two more Bf 110s probably flying this Hurricane. At the time he was a Flight Commander of No. 601 Squadron. His Hurricane sported an unusual marking of a red and white-striped lightning bolt and a red, white and blue spinner. The upper camouflage of the "B" pattern was done in standard colors. Robinson was appointed commander of No. 609 Squadron in October and took over command of Biggin Hill Wing from "Sailor" Malan in August 1941. In January 1942 he took command of Tangmere Wing. Unfortunately, on April 10, 1942, he and his wingman, Maurice P. C. Choron, did not return from a combat flight. They fell victims to the fighters of II./JG 26. "Mike" Robinson shot down a total of 16 aircraft, probably shot down five others and damaged nine.

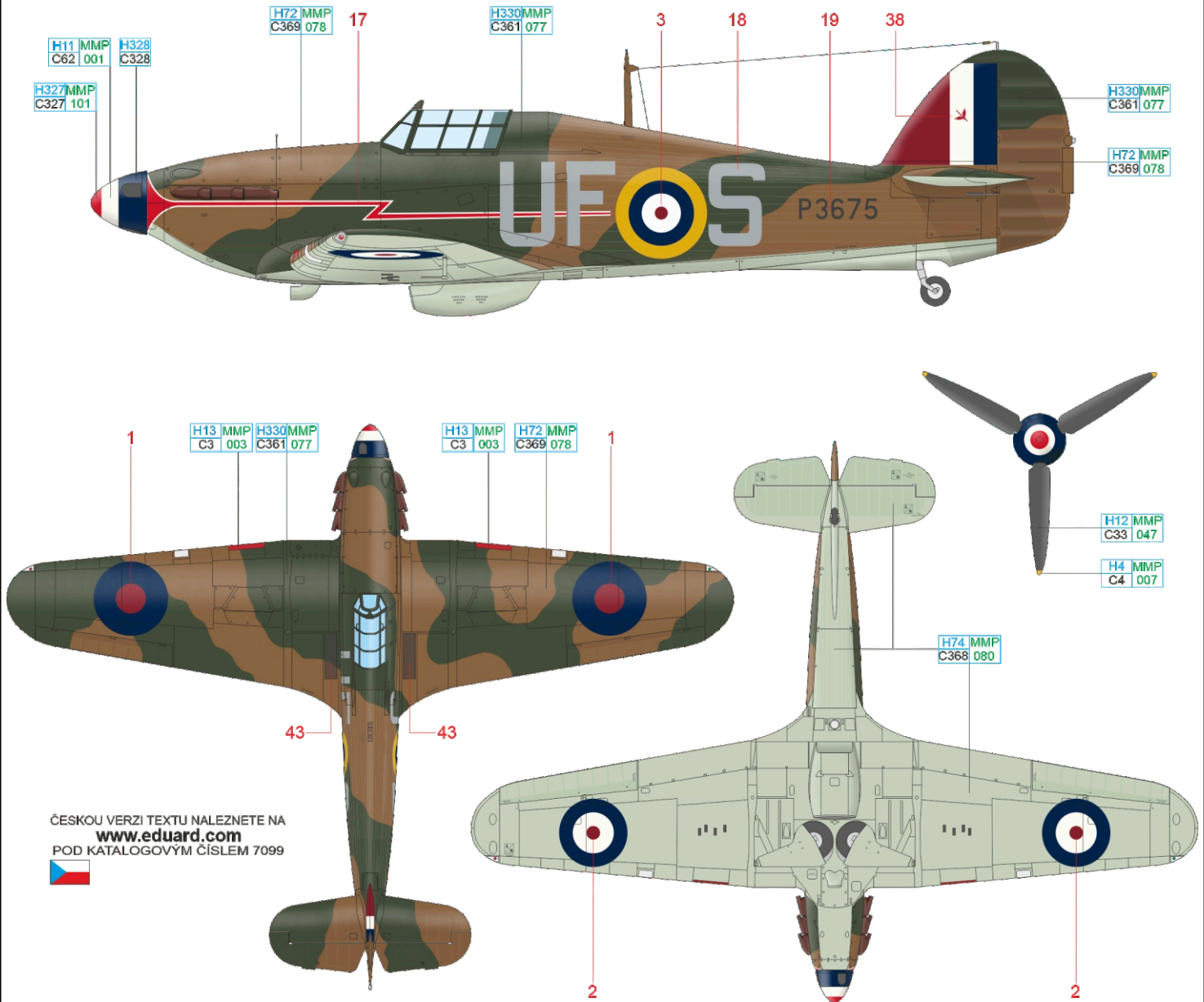

YELLOW	H4 MMP C4 007	FLAT BLACK	H12 MMP C33 047
DARK EARTH	H72 MMP C369 078	DARK GREEN	H330 MMP C361 077
SKY	H74 MMP C368 080	RED	H13 MMP C3 003
		RED	H327 MMP C327 101
		WHITE	H11 MMP C62 001
		BLUE	H328 C328

D V7419, S/Ldr Marmaduke Thomas St John Pattle, CO of No. 33 Squadron, Larissa, Greece, March–April 1941

Most of the historical records concerning the pilots fighting in the half-forgotten Greek battlefield were lost during the retreat across the Aegean Sea. It has therefore taken many years for historians to discover the fate of the Hurricane fighter pilots who served under the command of South African Major Marmaduke "Pat" Pattle. Research has confirmed that Pattle achieved 52 kills, of which 36 were achieved during his service with Nos. 80 and 33 Squadron when he was flying Hurricanes. This secured him the number one position among pilots of this type. One of the aircraft Pattle flew in combat was the Hurricane V7419. Due to the hectic times on the battlefield, most Hurricanes carried only NW squadron codes. Pattle did not see the end of the war. On the evening of April 20, 1941, he took off as leader of fifteen-strong Hurricane formation when they met superior number of Luftwaffe aircraft. After the outbreak of a fierce air battle over the Gulf of Eleusin, Pattle, although suffering from fever, managed to shoot down one Bf 109 and one Bf 110. Shortly after he was attacked by a pair of Bf 110s. He was last seen hurtling towards the sea in flames, pursued by a pair of Bf 110s which continued to fire. His body and the wreckage of the Hurricane were never found.

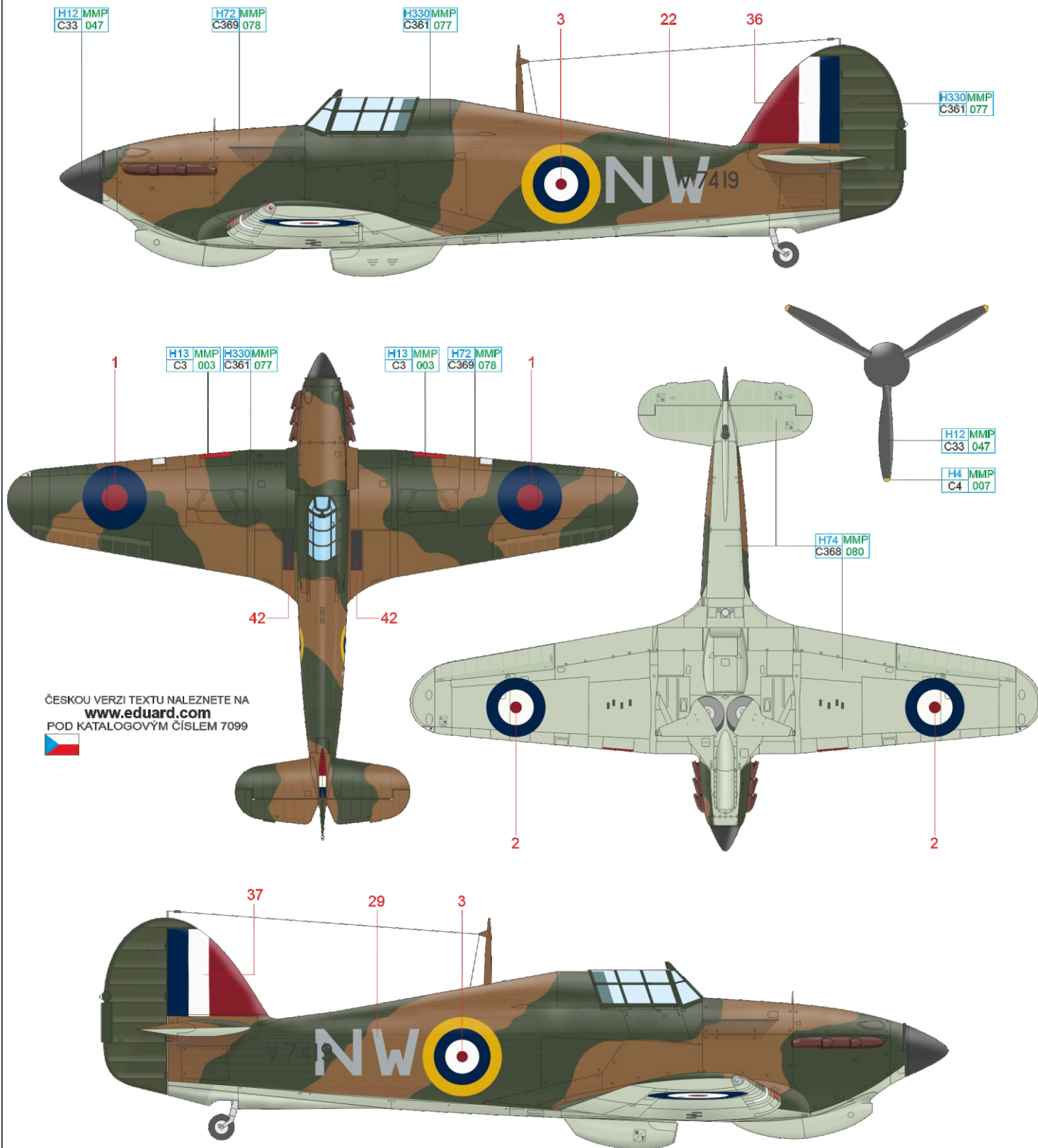

ČESKOU VERZI TEXTU NALEZNETE NA
www.eduard.com
 POD KATALOGOVÝM ČÍSLEM 7099



DARK EARTH	H72 MMP C369 078	DARK GREEN	H330MMP C361 077	SKY	H74 MMP C368 080	RED	H13 MMP C3 003	FLAT BLACK	H12 MMP C33 047	YELLOW	H4 MMP C4 007
------------	------------------	------------	------------------	-----	------------------	-----	----------------	------------	-----------------	--------	---------------

E V7743, No. 306 (Polish) Squadron, RAF Ternhill, Shropshire, Great Britain, March 1941

The third fighter unit of the Polish Air Force in Great Britain was No. 306 (Polish) Squadron, based at Church Fenton and established on August 28, 1940. It was equipped with the standard RAF fighter, the Hawker Hurricane. With these, the unit moved to Ternhill airfield in November of that year, from where the pilots conducted mainly patrol flights to protect convoys. Later, No. 316 (Polish) Squadron received Spitfires, with which they carried out attacks on targets in occupied Europe. Towards the end of the war the Spitfires were replaced by Mustang Mk.III's. The unofficial emblem of the squadron was a white, gold-lined diamond with a stylized wild duck and bear, the emblem of the original pre-war Torun Fighter Squadron of the Polish Air Force.

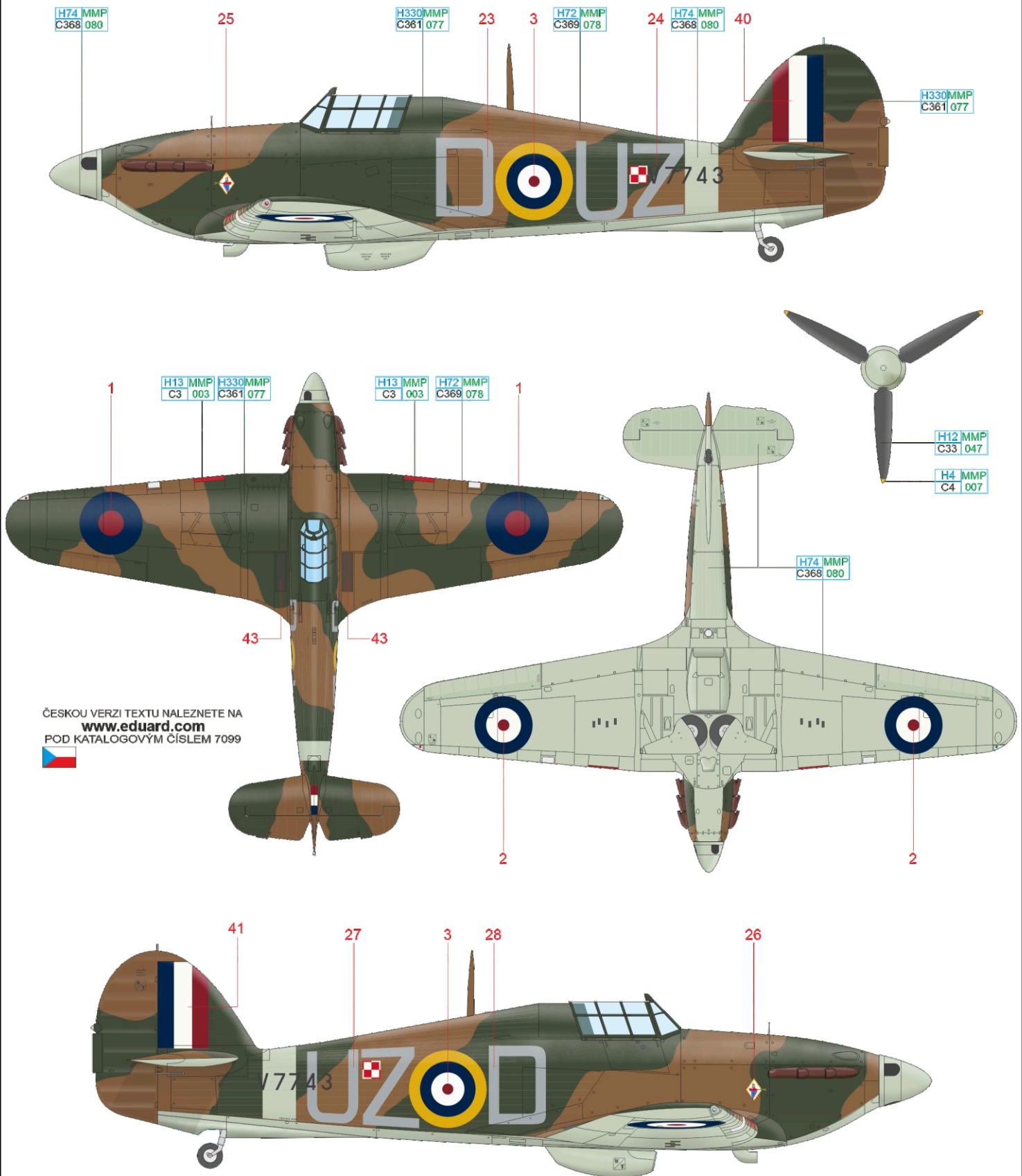

ČESKOU VERZI TEXTU NALEZNETE NA
www.eduard.com
 POD KATALOGOVÝM ČÍSLEM 7099

- | | | | | | | | | | | | |
|------------|------------------|------------|-------------------|-----|------------------|-----|----------------|--------|---------------|------------|-----------------|
| DARK EARTH | H74 MMP C368 080 | DARK GREEN | H330 MMP C361 077 | SKY | H74 MMP C368 080 | RED | H13 MMP C3 003 | YELLOW | H4 MMP C4 007 | FLAT BLACK | H12 MMP C33 047 |
|------------|------------------|------------|-------------------|-----|------------------|-----|----------------|--------|---------------|------------|-----------------|

F V7101, F/Lt George Burges, No. 69 Squadron, Luqa, Malta, May–June 1941

One of the founding members of the Gladiator Fighter Flight at Malta's Hal Far airfield was George Burges, who achieved seven victories in the defense of Malta in the cockpits of Gladiators and Hurricanes. He was transferred to No. 69 Reconnaissance Squadron at the end of January 1941. This unit also received Hurricane V7101 with reduced weight. It received additional fuel and oil tanks instead of armament, and its other equipment included two cameras behind the pilot's seat in place of the removed radios. George Burges flew it regularly until June 6, 1941, when he left Malta and returned to England. Hurricane V7101 was painted blue on all surfaces, and the only available photograph shows it with the rudder bearing a camouflage fields in Middle Stone and Dark Earth colors.

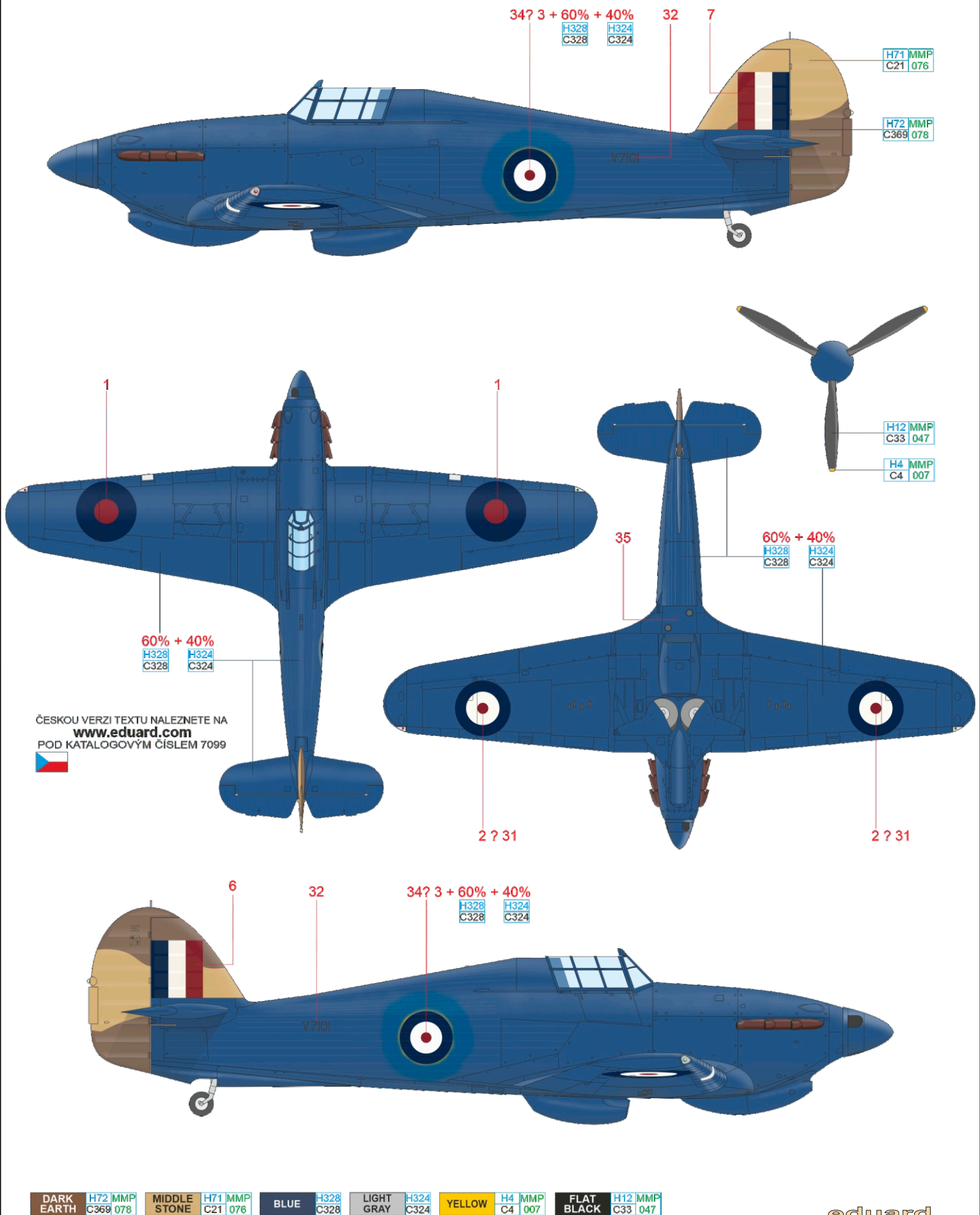

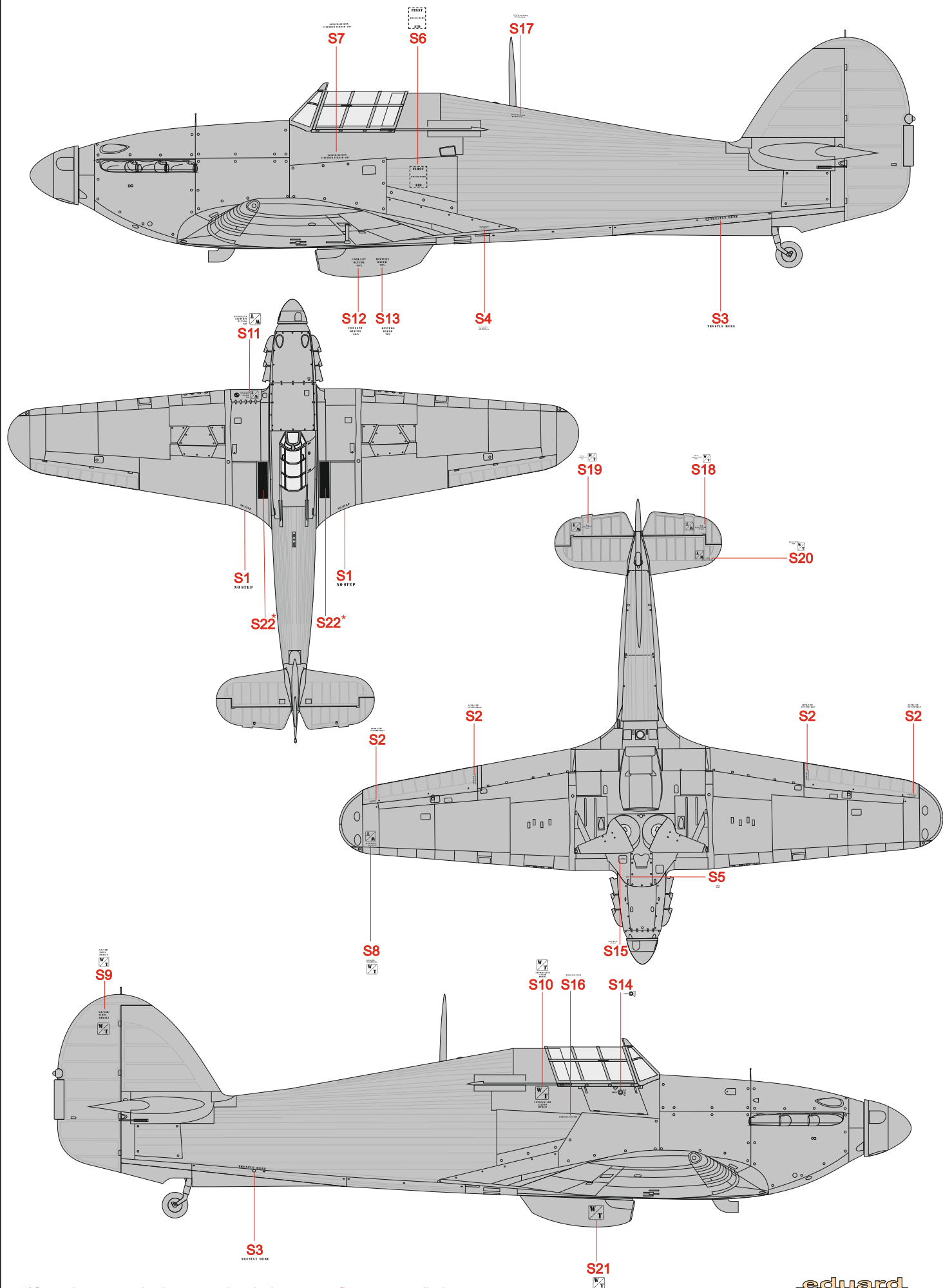

*Sometimes scratched or overpainted when camouflage was applied.

Eduard goodies for

Hurricane Mk.I 1/72

- 72685 Hurricane Mk.I landing flaps (PE-Set)
- 73036 Seatbelts RAF early STEEL (PE-Set)
- SS581 Seatbelts RAF early STEEL (PE-Set)
- D72036 Hurricane Mk.I stencils (Decal Set)

NO STEP S1	NO STEP S1	LEP/USE/! S2	LEP/USE/! S2	LEP/USE/! S2	LEP/USE/! S2
TRESTLE HERE		TRESTLE HERE			
S3	S3	S4	S5		
S6	S7	S8	S9	S10	
S11	S12	S13	S14		
S15	S16	S17	S18		
S19	S20	S21	S22		

Made in Czech Republic

Eduard M.A. © 2021

D72036-OBT1 Hurricane Mk.I stencils 1/72

eduard

72 685 Hurricane Mk.I landing flaps 1/72

© EDUARD 2019 Made in Czech Republic



1/72
F6F-3
Cat. No. 7457

A P3975, Sgt. Josef František, No. 303 (Polish) Squadron, RAF Northolt, United Kingdom, September 1940

Czechoslovak pilot Josef František, member of No. 303 (Polish) Squadron during the Battle of Britain, achieved three Luftwaffe kills flying this Hurricane. The first one was a Bf109E shot down on September 2. On September 9 he added a second kill of a Bf109E fighter plus one He 111 bomber

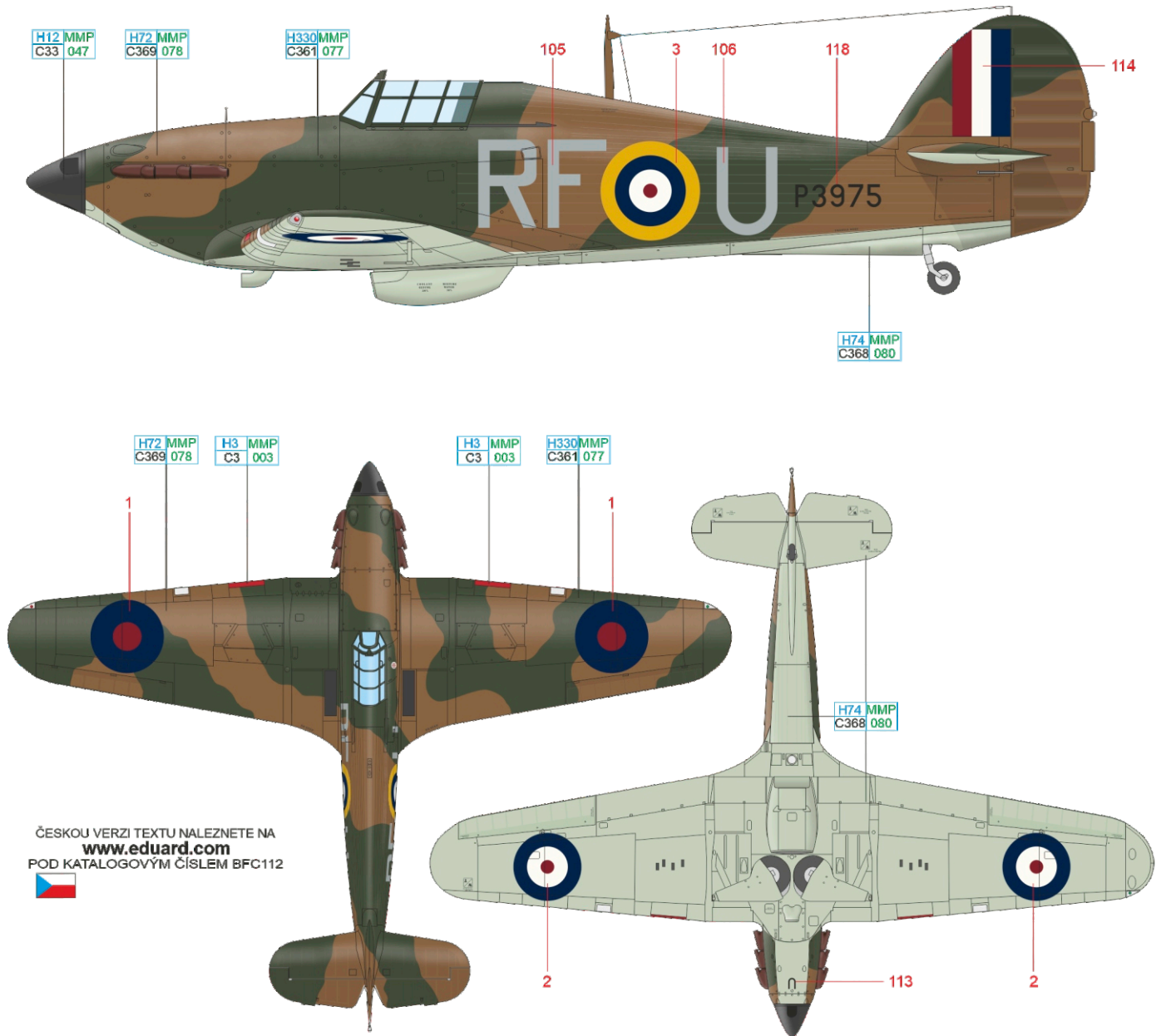

ČESKOU VERZI TEXTU NALEZNETE NA
www.eduard.com
 POD KATALOGOVÝM ČÍSLEM BFC112

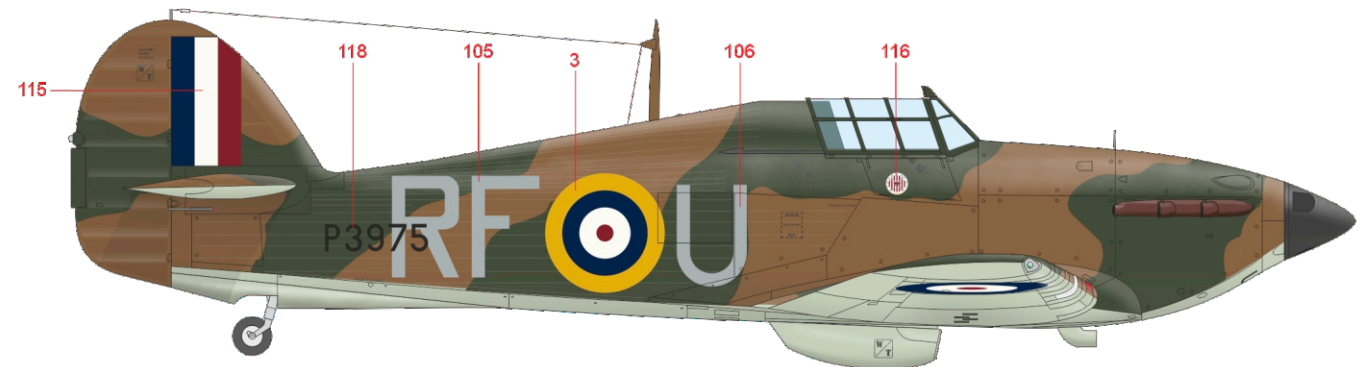

BLACK	H12 MMP C33 047	RED	H3 MMP C3 003
DARK EARTH	H72 MMP C369 078	DARK GREEN	H330 MMP C361 077
	SKY	H74 MMP C368 080	

B L2099, Sgt. Josef František, No. 303 (Polish) Squadron, RAF Northolt, United Kingdom, September 1940

Another Hurricane Sgt. František was flying during his time with No. 303 (Polish) Squadron was this aircraft from the early production batch, but with stressed-skin metal wing already fitted. Josef František flew this one on four missions, but he managed to score only once. It happened on September 30, 1940, when flying this Hurricane for the last time. His victim was one Bf 109E, another one was damaged. English commander of No. 303 (Polish) Squadron S/Ldr Ronald Gustave Kellert also flew this Hurricane several times.

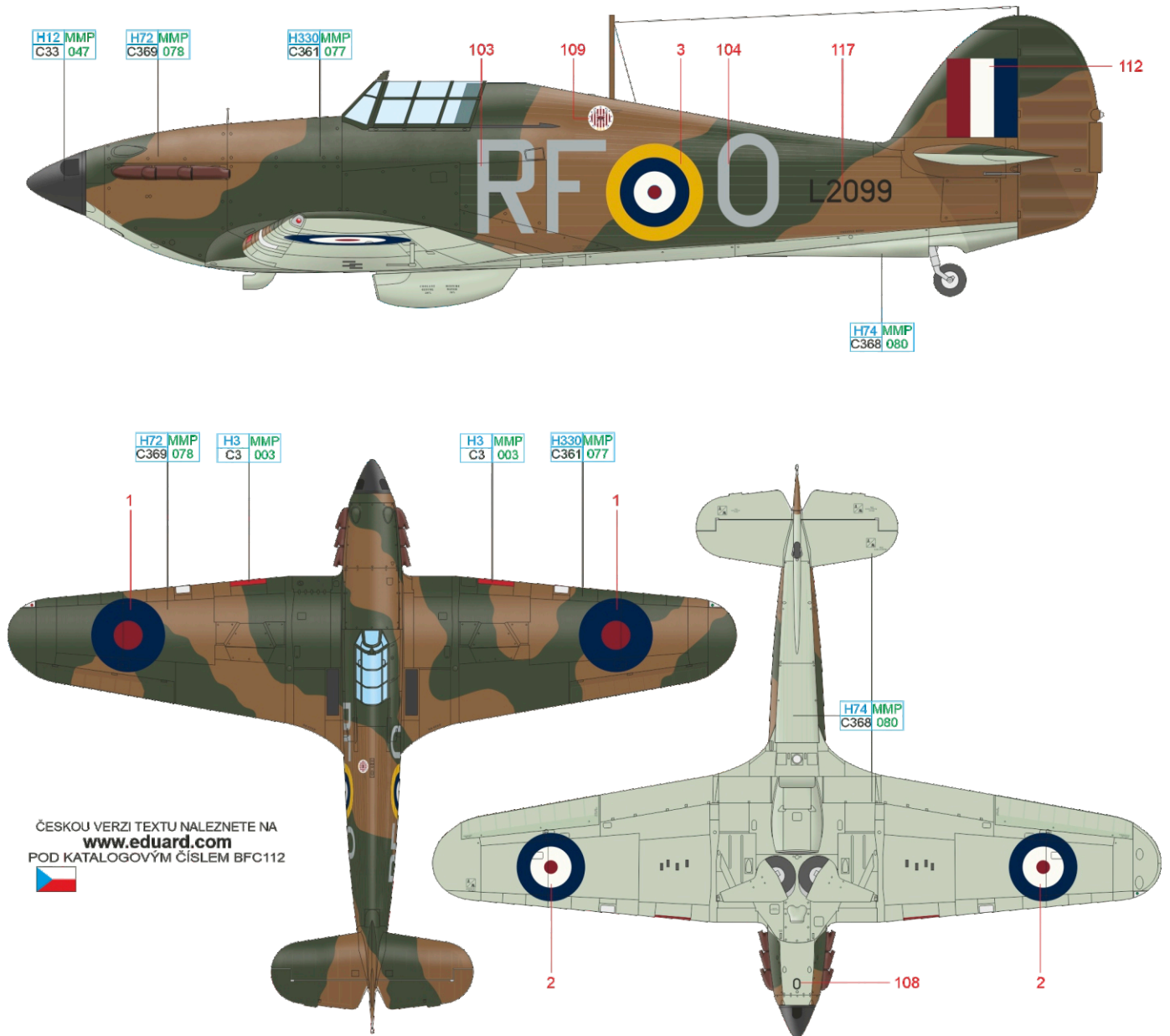

ČESKOU VERZI TEXTU NALEZNETE NA
www.eduard.com
 POD KATALOGOVÝM ČÍSLEM BFC112



BLACK	H12 MMP C33 047	RED	H3 MMP C3 003
DARK EARTH	H72 MMP C369 078	DARK GREEN	H330 MMP C361 077
	SKY	H74 MMP C368 080	

C R4175, Sgt. Josef František, No. 303 (Polish) Squadron, RAF Northolt, United Kingdom, September – October 1940

Probably the most famous František's Hurricane was the one coded RF-R. The Czechoslovak fighter ace scored a total of eight kills flying it (on September 3 one Bf109E, on September 5 one Ju 88 and one Bf109E, on September 6 one Bf109E, on September 26 two He 111 and on September 27 one Bf110 and one Bf109E). However, this Hurricane became František's fate, as he crashed it on October 8, 1940 and was killed.

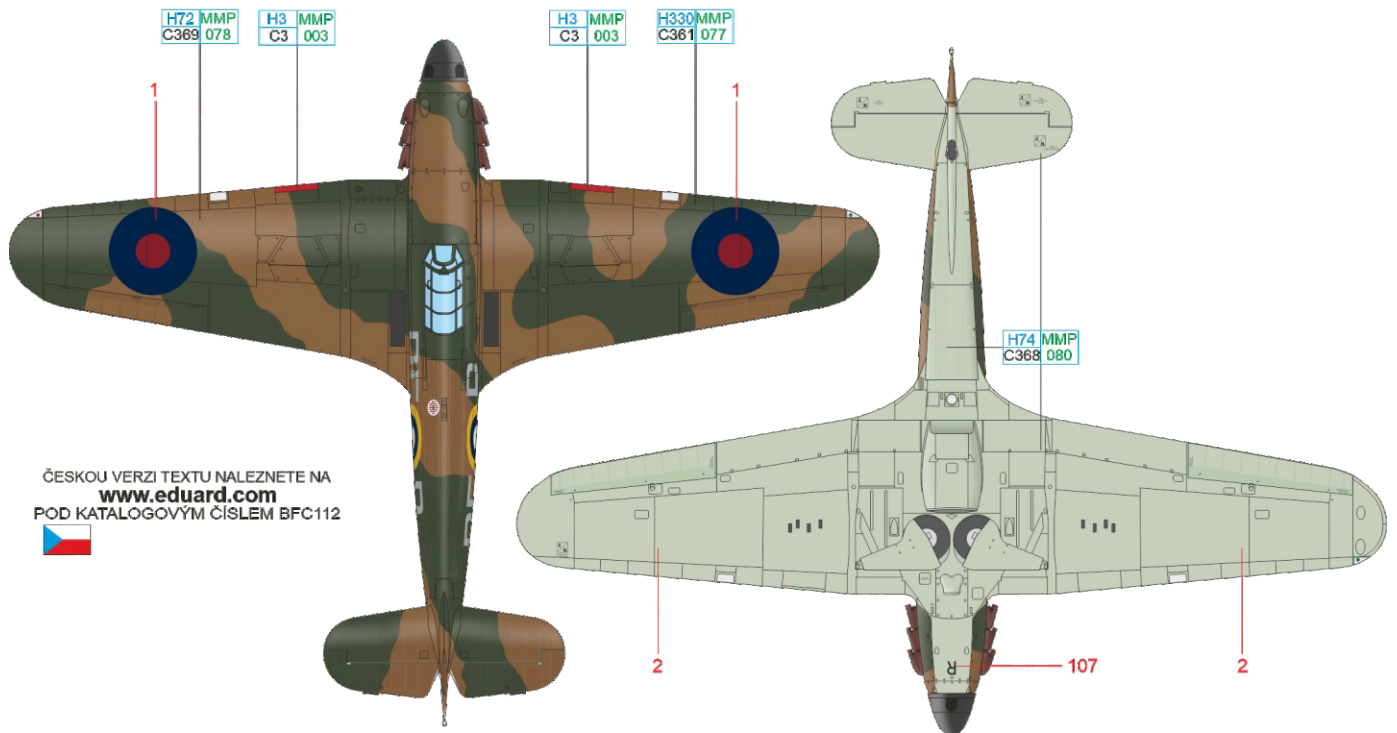
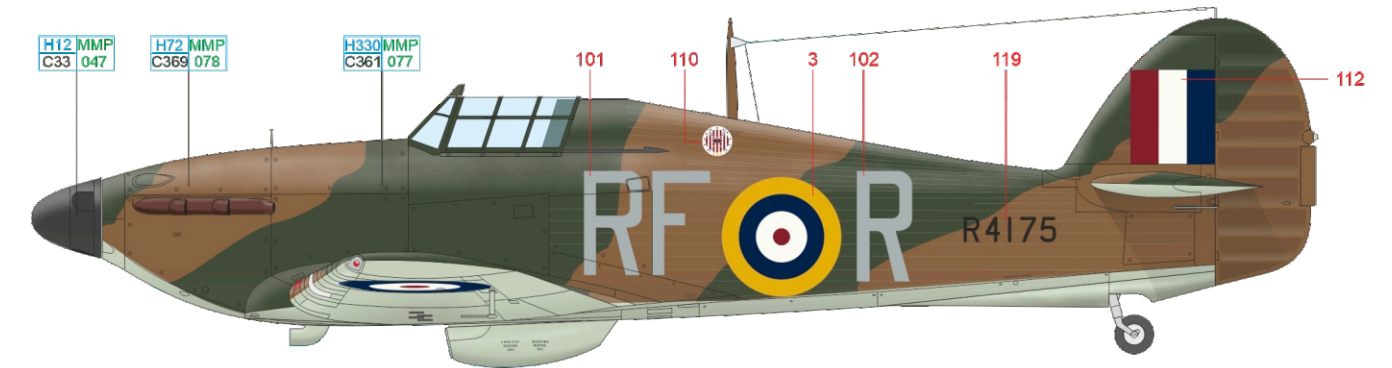

ČESKOU VERZI TEXTU NALEZNETE NA
www.eduard.com
POD KATALOGOVÝM ČÍSLEM BFC112

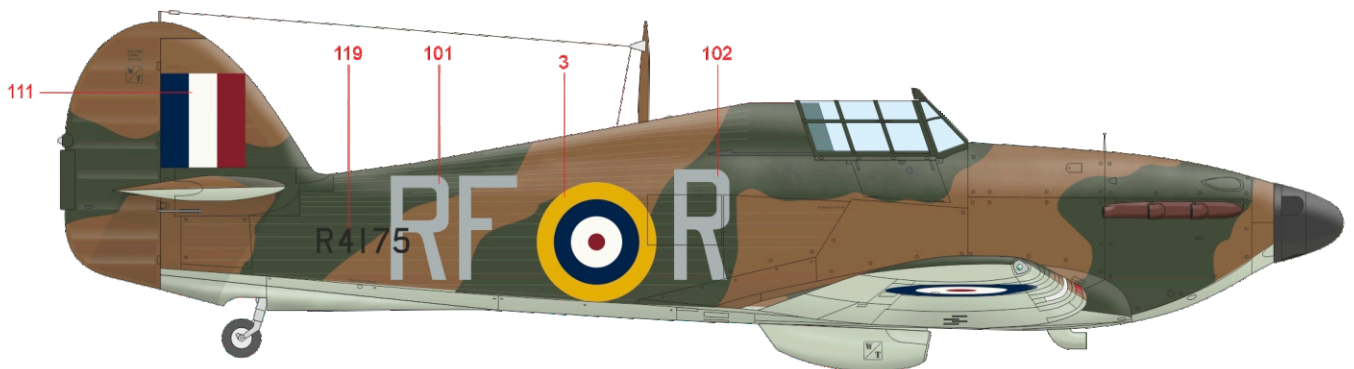

BLACK	H12 MMP C33 047	RED	H3 MMP C3 003
DARK EARTH	H72 MMP C369 078	DARK GREEN	H330 MMP C361 077
	SKY	H74 MMP C368 080	