

SCALE  
1/12  
USS SB2C-4E  
Helldiver

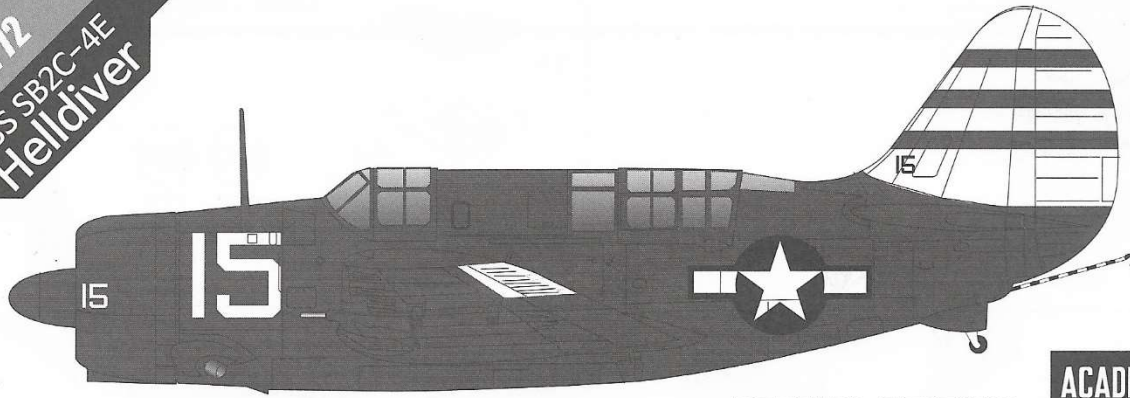

**SPECIAL EDITION**  
with limited availability

**ACADEMY**  
HOBBY MODEL KITS

12545

Warning in Assembly of Model Kits  
조립전의 주의사항

Take care not to injure yourself while using the modeling tools to cut or trim parts.  
공구를 이용하여 부품을 다듬고 자를 경우, 손을 다치지 않도록 주의를 기울여 주십시오.



**CAUTION!**  
-주의-

<READ THIS BEFORE YOU BEGIN>  
<ALLGEMEINE HINWEISE>  
<LISEZ CE QUI SUIT AVANT DE COMMENCER LE MONTAGE>  
<組み立てる前に>  
<조립하기 전에 먼저 읽어 주십시오>

**<READ THIS BEFORE YOU BEGIN>**

- Study the instructions before assembling. - Check the fit of each piece before cementing into place.
- Do not use too much cement to join parts. - Never use cement or paint near open flame.
- Open a window or make area well ventilated when cement or paint is in use.
- Tear up and throw away the empty plastic bags to avoid danger of suffocation for little children.

**<ALLGEMEINE HINWEISE>**

- Die Anordnung der Bauteile ist aus den Zeichnungen der Anleitung ersichtlich.
- Die Teile vor dem Verkleben ungleichmäßig zusammenhalten, um ihren paßsitz zu prüfen.
- Klebstoff nicht zu dick auftragen. - Klebstoff und Farben niemals in der Nähe einer Flamme verwenden.
- Während der Bemalung mit Spritzpistole oder Pinsel für frische Luftzufuhr, z.B. öffnen des Fensters, sorgen.
- Bausatz von kleinen Kindern fernhalten. Verhüten Sie, daß Kinder irgendwelche Bauteile in den Mund nehmen oder Plastiktüten über den Kopf ziehen.

**<LISEZ CE QUI SUIT AVANT DE COMMENCER LE MONTAGE>**

- Etudier les schémas d'assemblage. - Contrôler que chaque pièce soit bien conforme avant de la coller à sa place.
- N'utilisez pas trop de colle pour réunir les pièces. - Ne faites jamais manipuler la colle ou peinture à proximité d'une flamme.
- Aérer soigneusement la pièce où vous peignez(ouvrir la fenêtre).
- Après avoir sorti les pièces du sac en plastique, déchirer le sac afin d'éviter que les enfants ne le mettent sur la tête et ne s'étouffent.

**<組み立てる前に>**

- 組み立てる前に説明書をお読み下さい。 - 部品をランナーから切りはなす時は模型用ニッパーとカッターを使用します。
- 接着剤を少しなめに使うことがきれいに仕上げるコツです。 - 接着する前に部品を合わせて確かめます。
- 接着剤や塗料を使用する時はときどき窓を開けて換気をお願いします。
- 組み立て後の部品やビニール袋は小さな子供の手の届かない安全な所に保管して下さい。

**조립하기 전에**

- 부품을 조립하기 전에 설명서를 잘 읽어본 후 조립한다.
- 점착하기 전에 부품을 맞추어 확인한 후 조립한다.
- 부품을 자를 때에는 칼이나 나퍼로 깨끗이 잘라준다.
- 점착제를 사용할 곳과 사용하지 않는 곳에 주의하고 너무 많이 바르지 않도록 한다.
- 에나멜 페인트나 점착제를 사용할 때는 창문을 열어 환기를 시키고 화기를 멀리한다.
- 사용 후 남은 부품은 어린 아이들의 손에 닿지 않도록 잘 처리한다.



점착제 사용



점착제 금지



수만큼 조립



전사지



무게추



채움



칼라냄



선택



반대측 조립



뚫어줌



주의



버전

MAIN COLOR	5 FLAT BLACK FS37038 무광 검정색		8 NAVY BLUE FS15042 네이비 블루				15 ZINC CHROMATE TYPE1 FS34151 징크 크로메이트							
	PAINT INDEX		Humbrol		GSI Creos		Lifecolor		TESTORS / MODELMASTER		Revell		Vallejo	
	ENAMEL	ACRYL	AQUEOUS HOBBYCOLOR	Mr. COLOR		ENAMEL	ACRYL	ENAMEL	ACRYL	MODEL COLOR	MODEL AIR			
RED FS11136	19	19	H3	3	LC56	1503	2741	32131	36131	957	84		유광 빨간색	
SILVER	11	11	H8	8	LC74	2914	4678	32190	36190	997	63		은색	
STEEL	53	53	H18	28	LC76	1795	4681	32191	36191	863	72		스틸	
YELLOW FS13538	188		H329	329	LC53	1707	4683	32310	36310	953	2		유광 노란색	
FLAT BLACK FS37038	33	33	H12	33	LC02	1749	4768	32108	36108	950	57		무광 검정색	
CLEAR RED	1321		H90	47			4630			934			투명 빨간색	
CLEAR ORANGE			H92	49									투명 오렌지	
CLEAR BLUE	1320		H93	50			4658			938			투명 파란색	
INTERMEDIATE BLUE FS35164	144		H42	366	UA045	1720	4744			903			인터미디어이트 블루	
BURNT IRON			H76	61		1424	4216						버트아이언	
OLIVE DRAB FS34087	155		H52	12	UA003	1711	4728			887	43		올리브 드랍	
DARK GHOST GRAY FS36320	128	128	H307	307	UA027	1741	4761	32374	36374	905	47		다트 고스트 그레이	
WHITE FS17875	22	22	H316	316	LC51	1745	4696	32104	36104	842			흰색	
NAVY BLUE FS15042	181		H54	14	UA047	1717	4686	32350	36350	898	87		네이비 블루	
ZINC CHROMATE TYPE1 FS34151	151		H58	27	UA004	1715	4735			833	10		징크 크로메이트	

**1** CEMENT  
접착제 사용

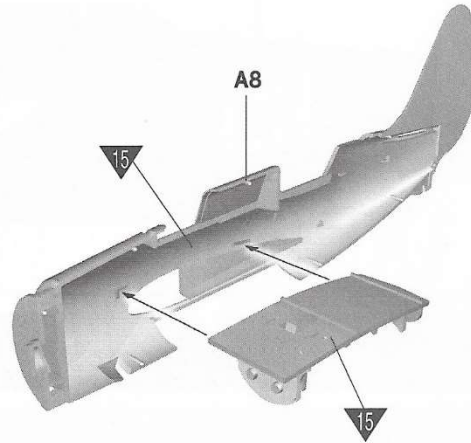
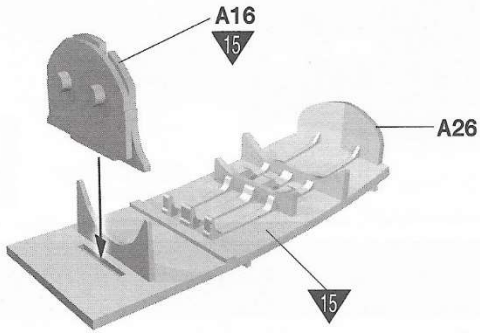

**2** CEMENT  
접착제 사용

※ Start assemble with number ①  
①번부터 조립 합니다.

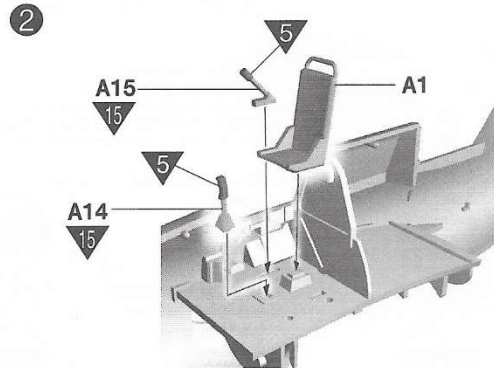
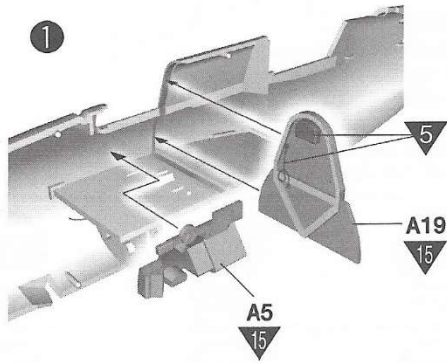

**3**

**4**

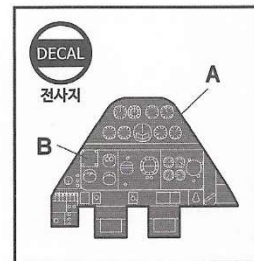
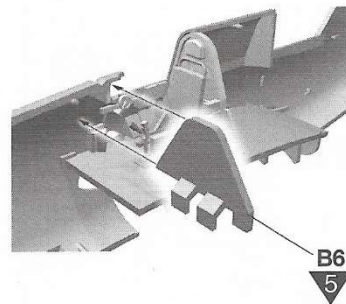
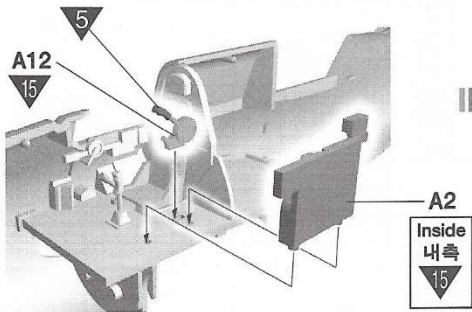



3



접착제 사용

※ Start assemble with number ①  
①번부터 조립 합니다.

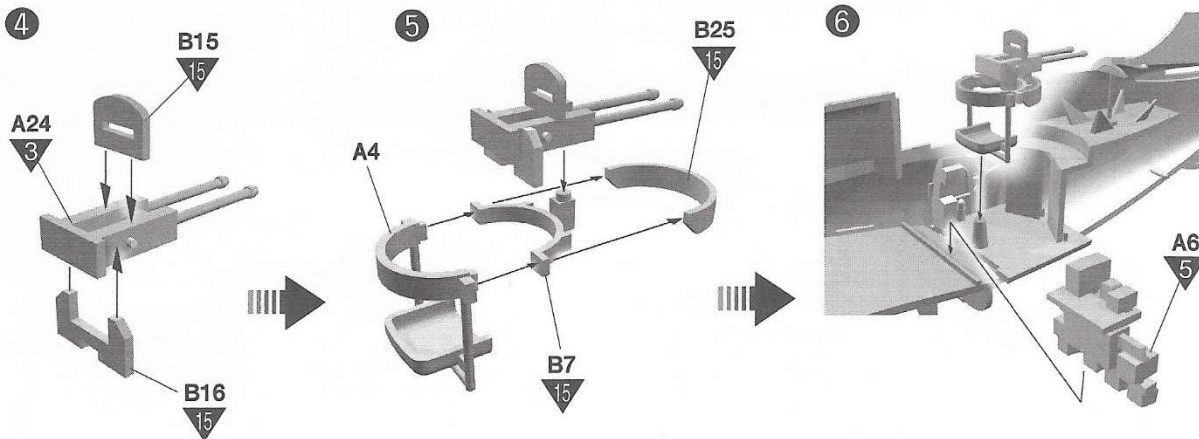
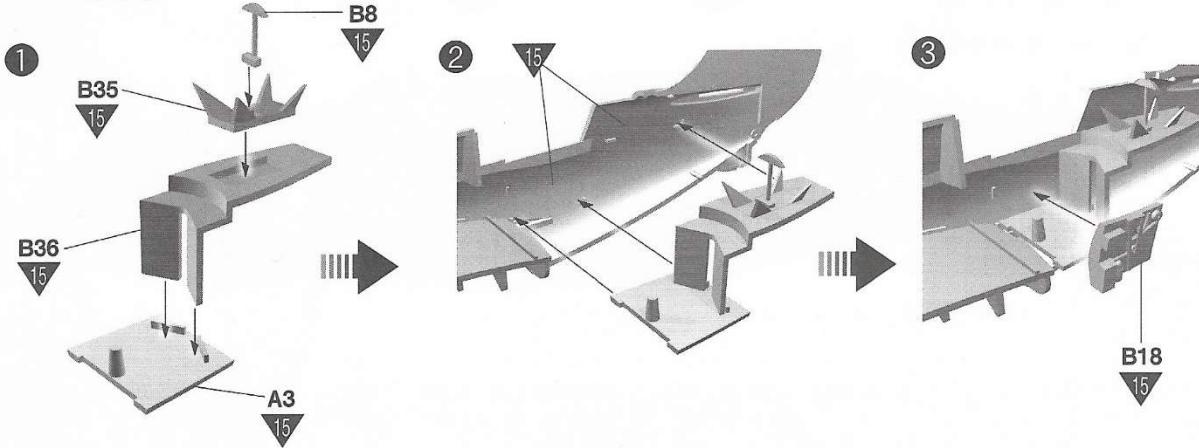

4



접착제 사용

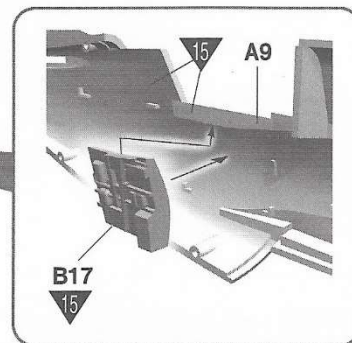
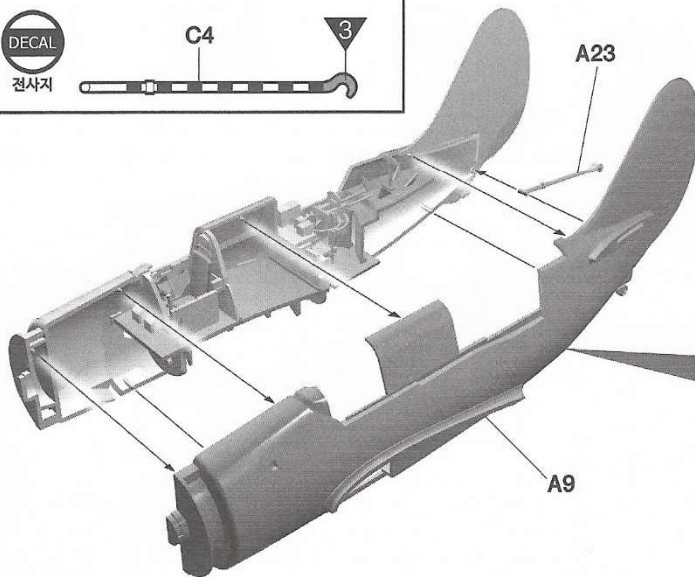
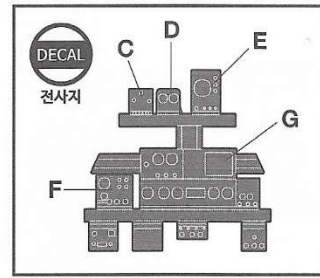
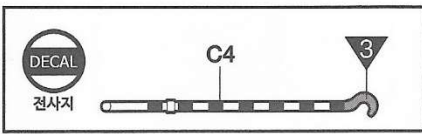

5

CEMENT  
접착제 사용

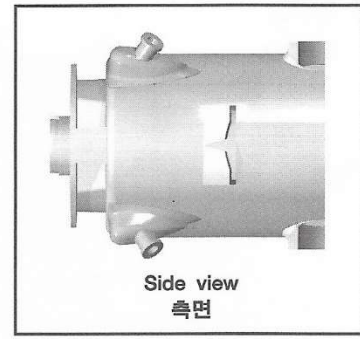
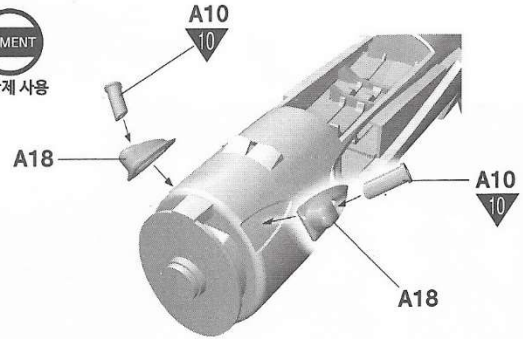

6

CEMENT  
접착제 사용

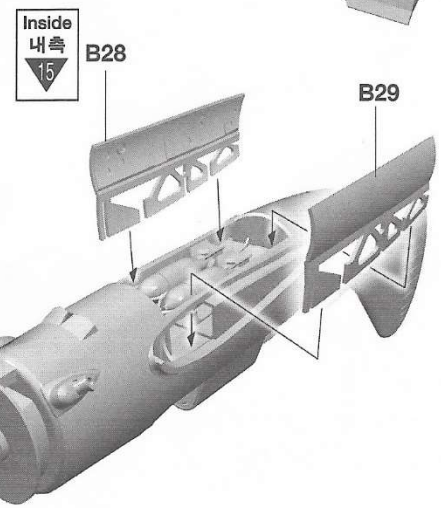
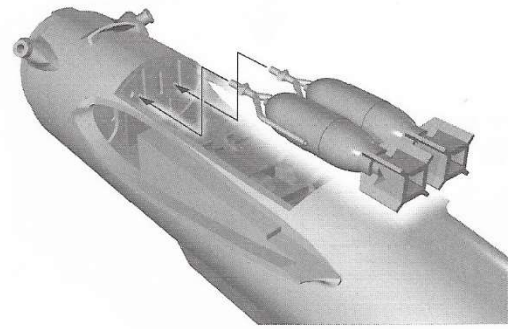
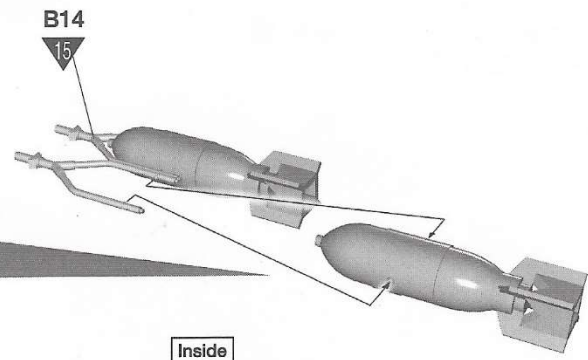
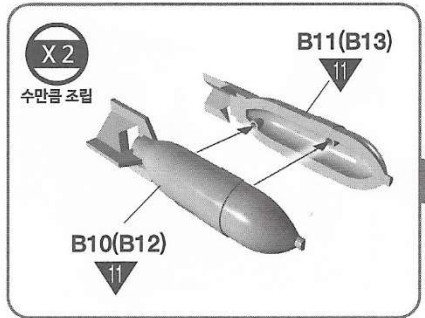

7

CEMENT  
접착제 사용

※ Photo etched parts assembly: 9~11page of Manual2  
에칭이 적용되는 부분으로, Manual2의 9~11페이지를 참조하세요.

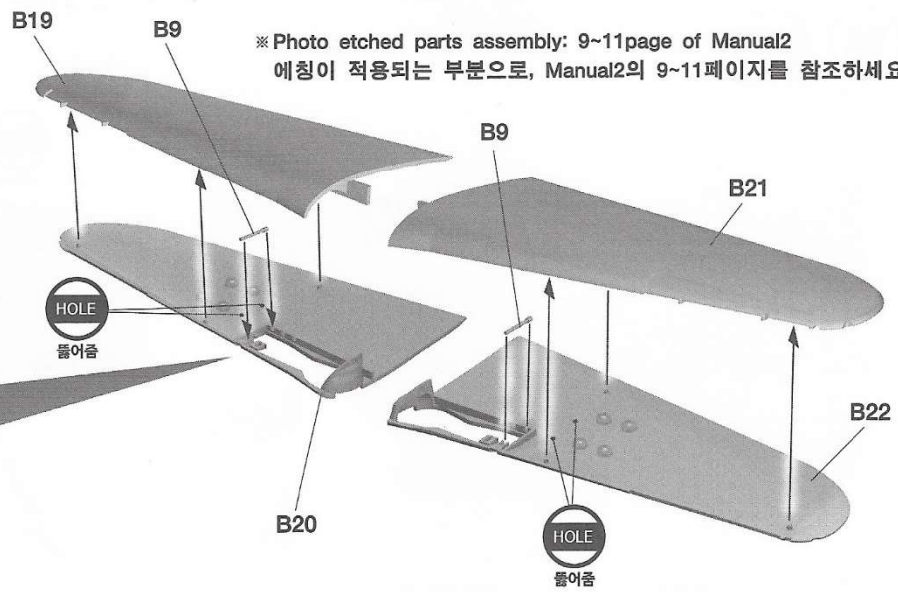



8

CEMENT

접착제 사용

CUT  
잘라냄

OPT  
선택

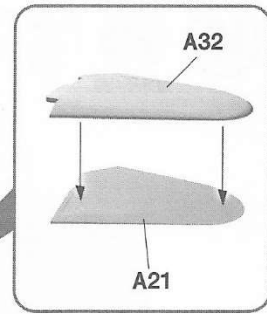
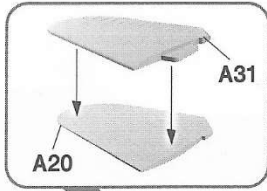

B24

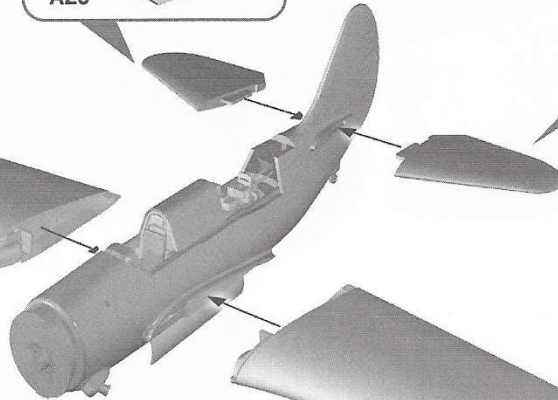
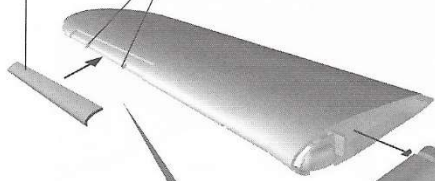

CUT  
잘라냄

OPT  
선택

B23

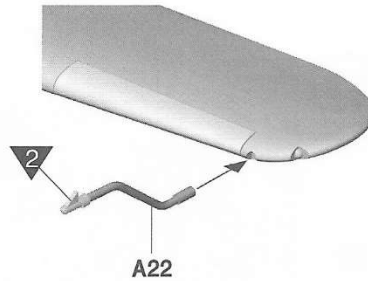
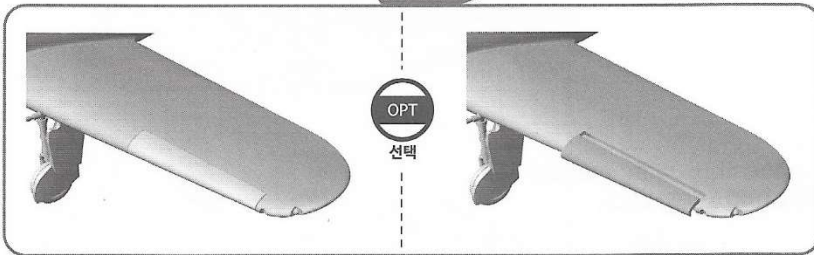
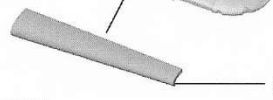

9

CEMENT

접착제 사용

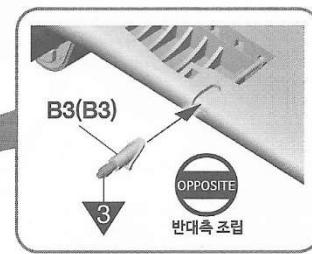
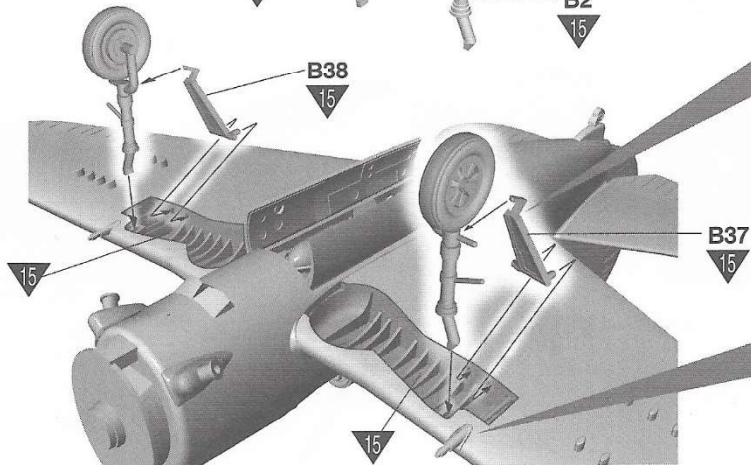
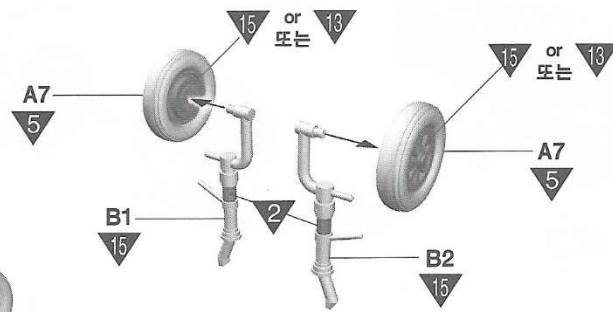

10

CEMENT  
접착제 사용

Inside  
내측  
15

B34

Inside  
내측  
15

B31

B33

B32

11

CEMENT  
접착제 사용

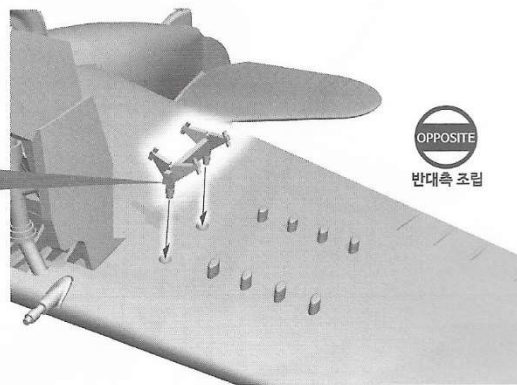
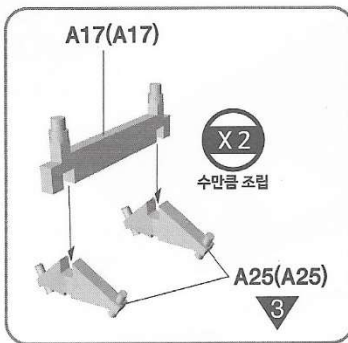

12

CEMENT  
접착제 사용

※ Start assemble with number ①  
①번부터 조립 합니다.

①

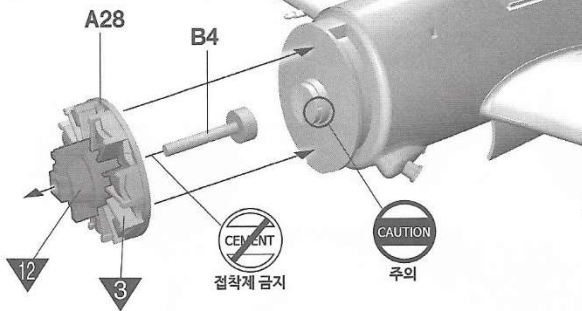

②

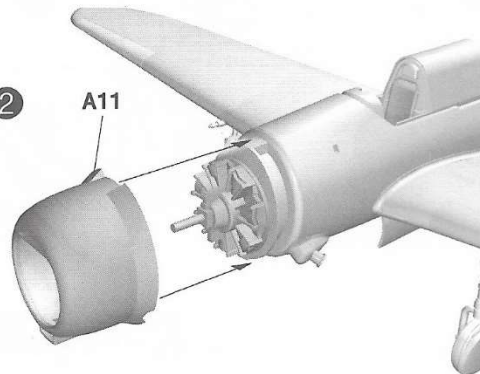

③

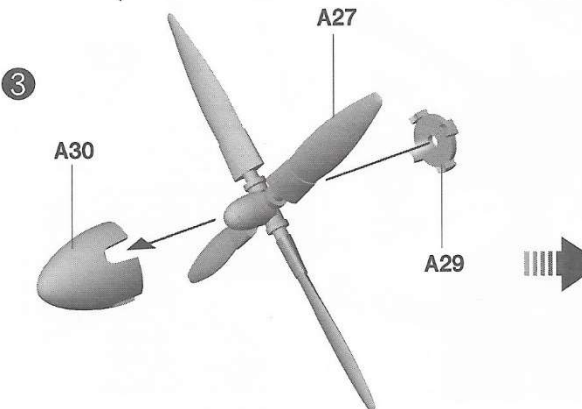

④

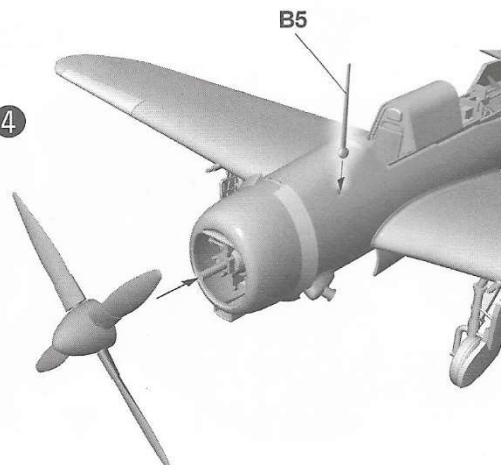



13



접착제 사용

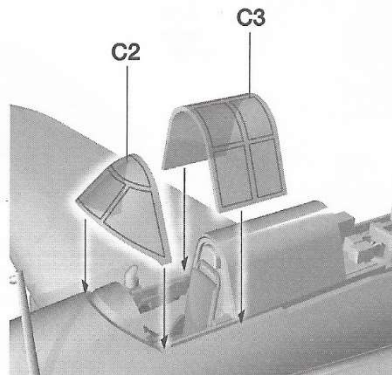
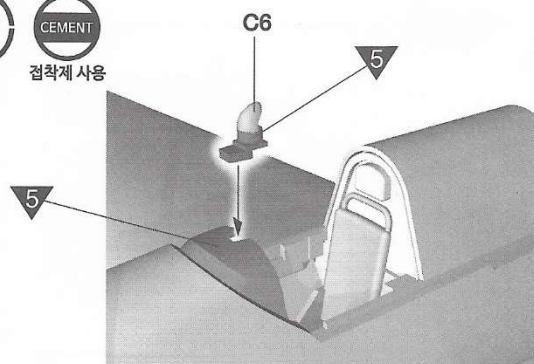

※ Start assemble with number ①

①번부터 조립 합니다.

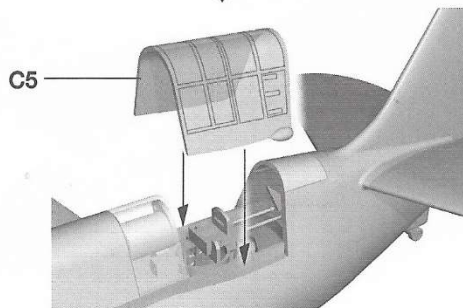
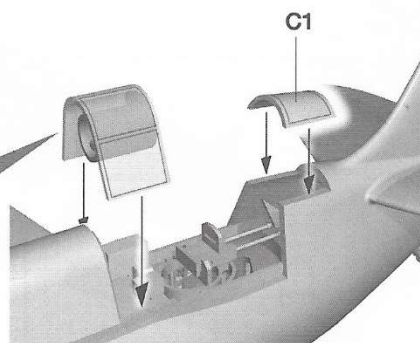
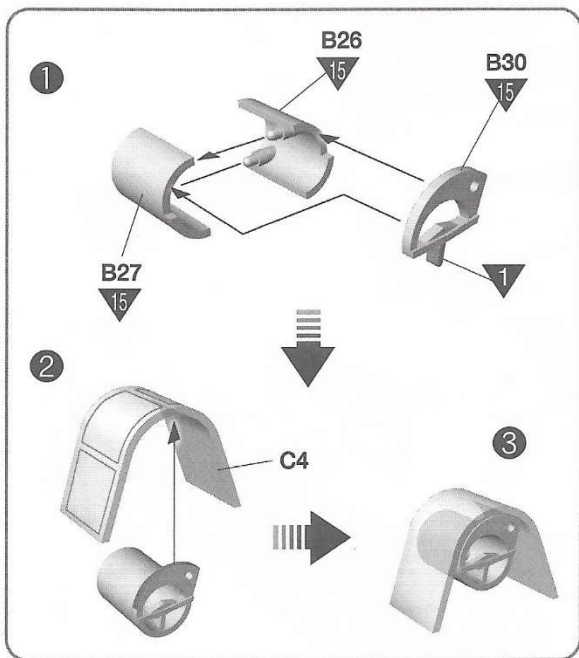

14



접착제 사용

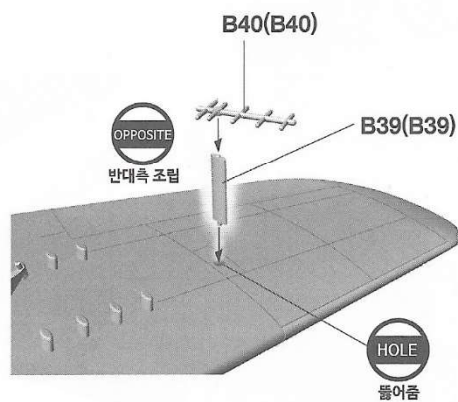
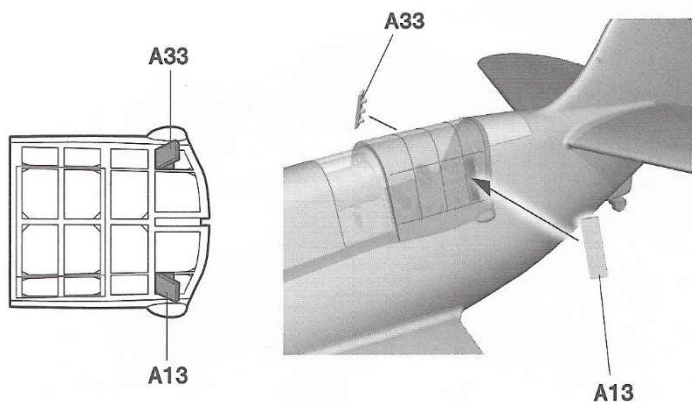

※ To be continued manual second time!  
두번째 설명서로 이어집니다!

parts location diagram/ 부품도

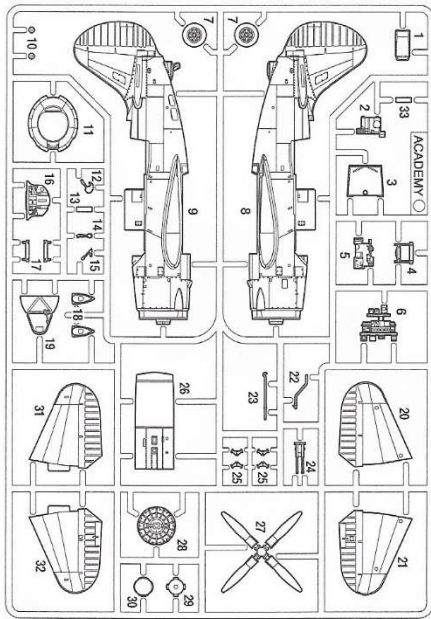

A

B

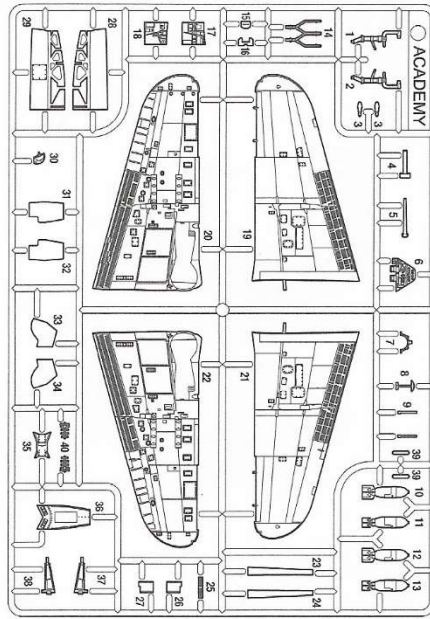

C

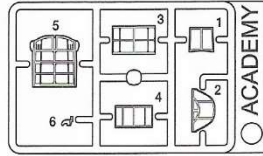

- Decal/전사지
- Photo etched parts/에칭

painting & decal placement/ 색칠 및 전사지붙이기

<Common data>  
공통데이터

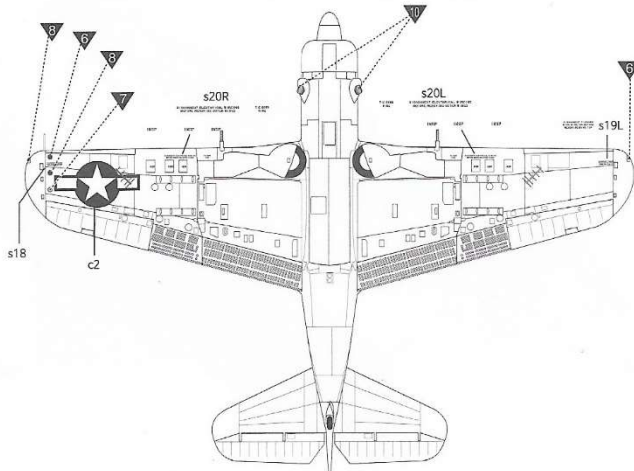
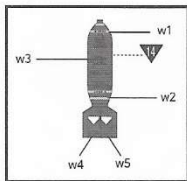
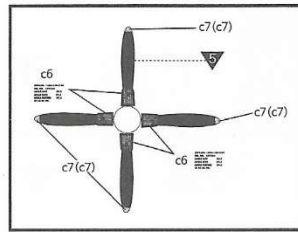
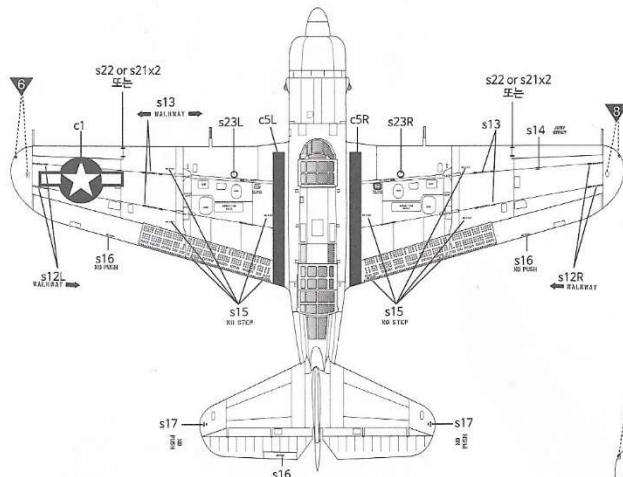
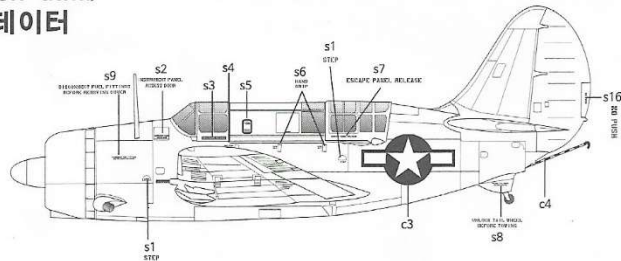
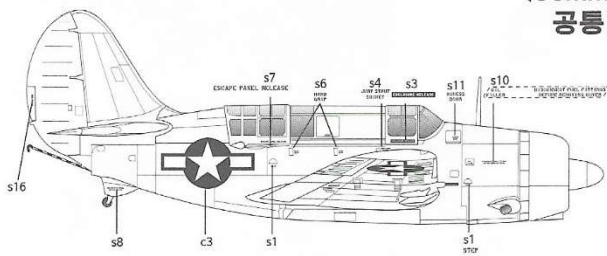

**ACADEMY**  
HOBBY MODEL KITS

**ACADEMY**  
ACADEMY PLASTIC MODEL CO., LTD.  
고객상담문의: 031-850-8555



▶ photo etched parts assembly/ 에칭조립

● Applying Photo Etched Parts/ 에칭 부품 적용방법

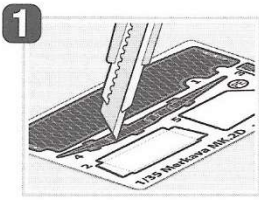

**1**  
Cut off Photo Etched parts using a utility knife carefully.  
사용하려는 에칭 파트를 커터칼로 조심스럽게 잘라냅니다.

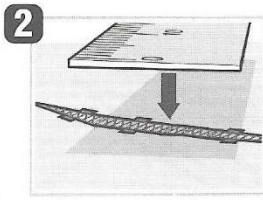

**2**  
Place a flat object like a ruler on the Etched parts.  
접지 않으려는 부분 위에 자와 같이 평편하며 굴곡이 없는 물체를 올려 흔들리지 않게 눌러 줍니다.

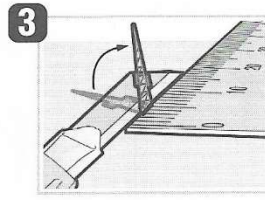

**3**  
Place the knife under to bend. And carefully lift the side of the knife to fold the etched parts.  
구부리려는 부분 아래에 커터칼을 넣고 커터칼의 뒷쪽을 조심스럽게 들어올려 에칭을 접습니다.

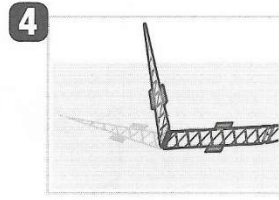

**4**  
Desired position is folded neatly without damaging other places.  
다른 부분의 손상없이, 원하는 부분의 에칭만을 깔끔하게 접을 수 있다.

Icon for photo etched parts  
포토 에칭 부품 아이콘

PE Photo Etched Part.  
포토 에칭 부품입니다.

Bend  
에칭을 접으십시오.

Use instant glue  
순간접착제를 사용하십시오.



※ ( ) is right number.  
( )는 오른쪽 번호입니다.

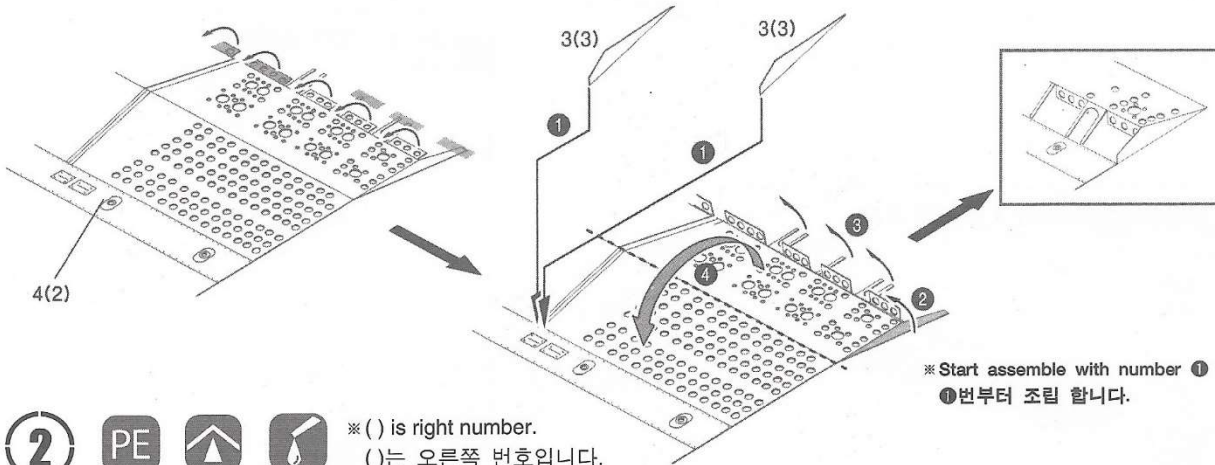

※ Start assemble with number ①  
①번부터 조립 합니다.



※ ( ) is right number.  
( )는 오른쪽 번호입니다.

※ Please refer to step ③.  
과정 ③을 참조해 주십시오.

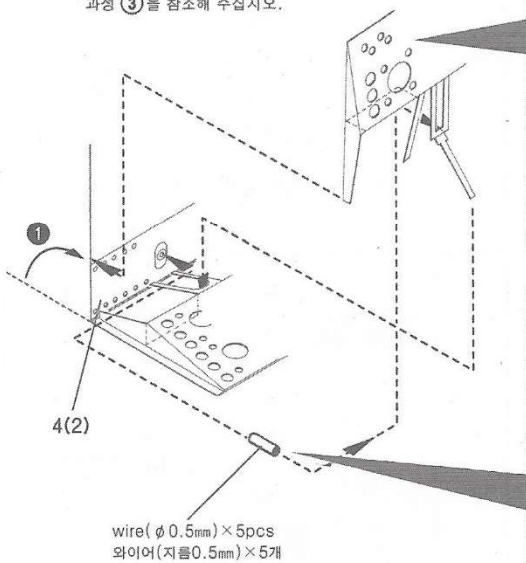

wire (φ 0.5mm) × 5pcs  
와이어(지름0.5mm) × 5개

※ do not use wire for closed position.  
닫힌상태로 조립시엔 와이어를 사용하지 않습니다.

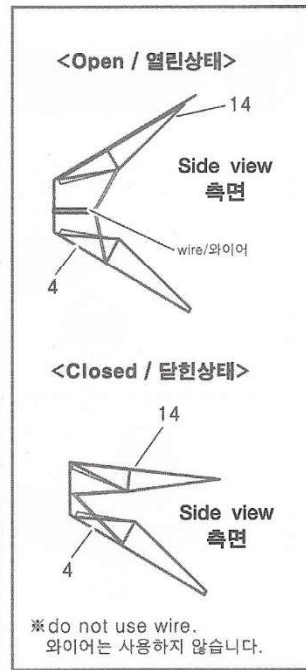
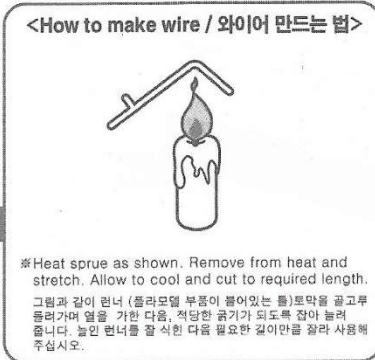
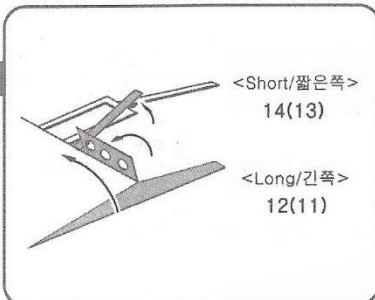

3

PE



\* Start assemble with number ①  
①번부터 조립 합니다.

※ ( ) is right number.  
( )는 오른쪽 번호입니다.

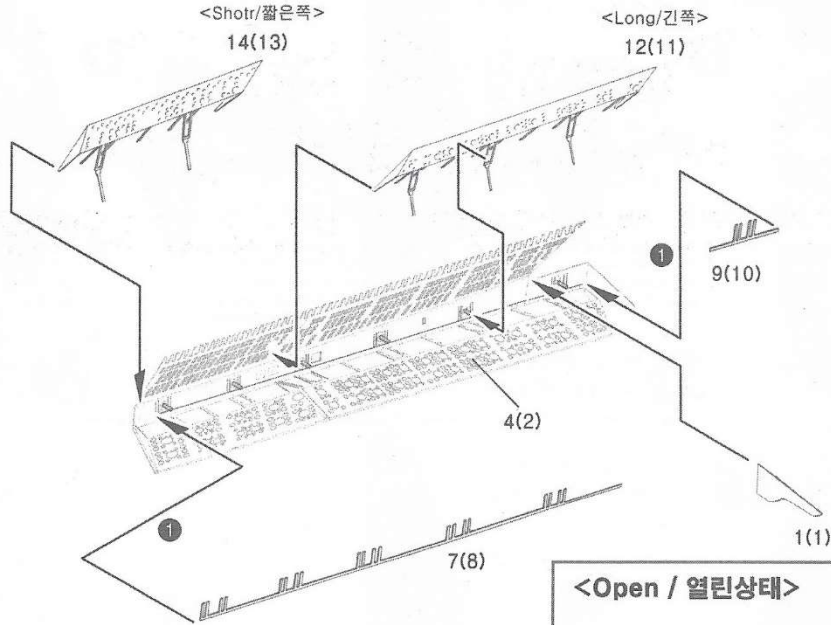

**Final assembly / 완성된 모습**

Left  
왼쪽

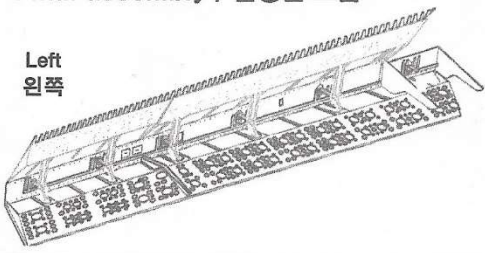

**<Open / 열린상태>**

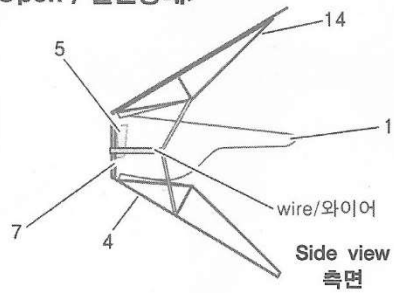

**<Closed / 닫힌상태>**

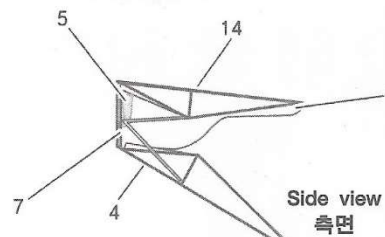

※ do not use wire.  
와이어는 사용하지 않습니다.

4

Applied part of photo etched  
에칭의 적용부분

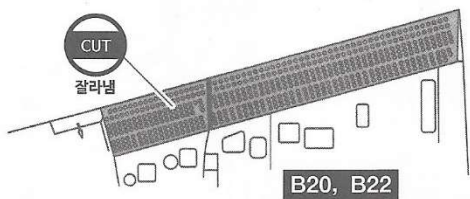
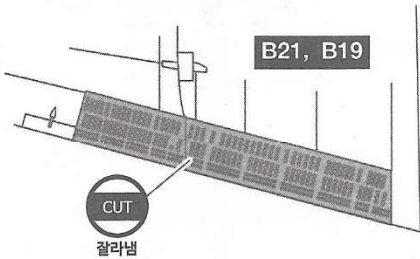

B21(B19)

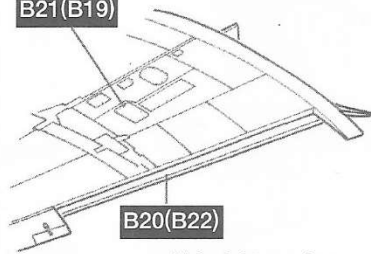

B20(B22)

※ ( ) is right number.  
( )는 오른쪽 번호입니다.



5

PE



※ ( ) is right number.  
( )는 오른쪽 번호입니다.

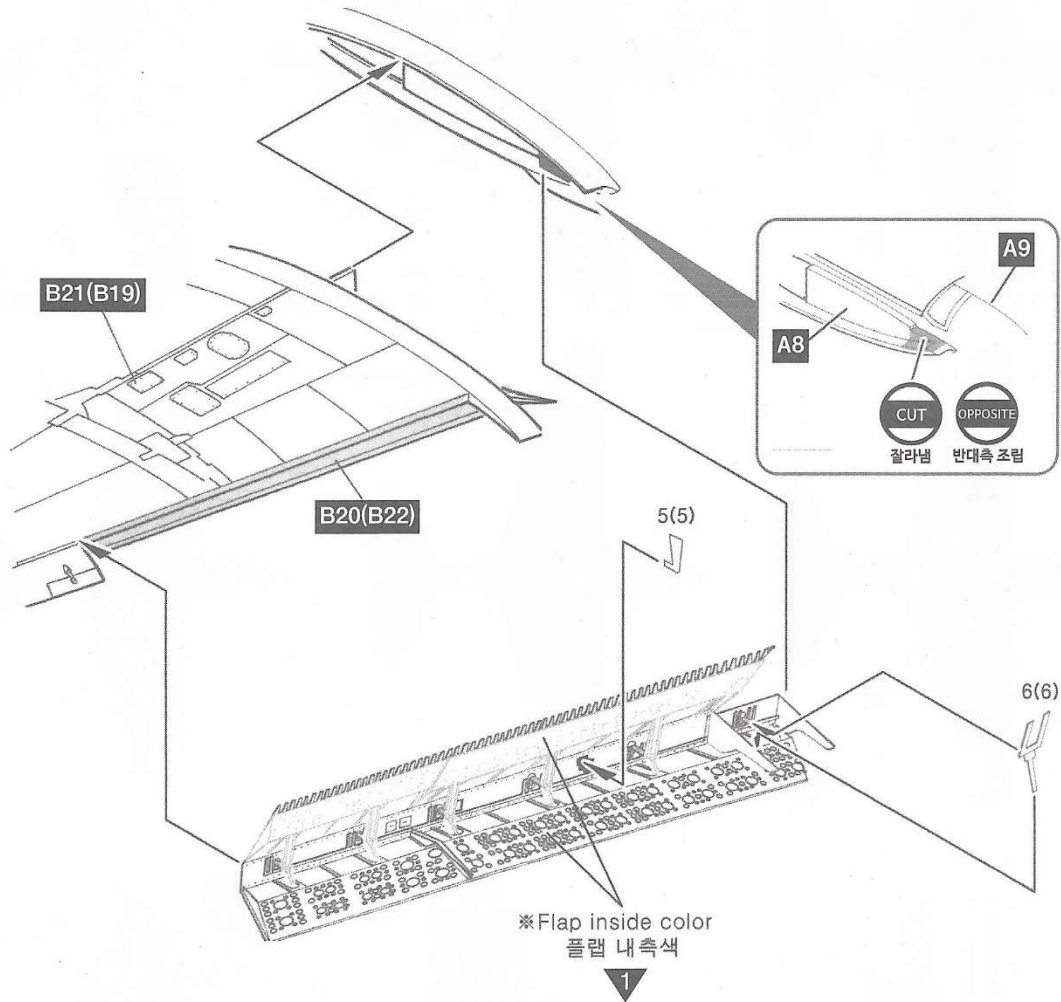

< Open / 열린상태 >

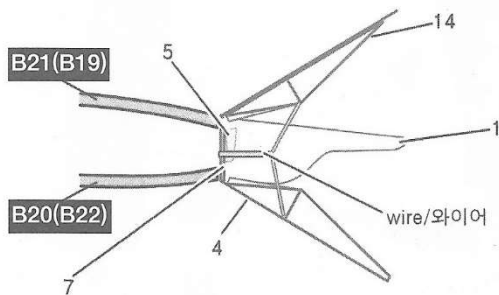

< Closed / 닫힌상태 >

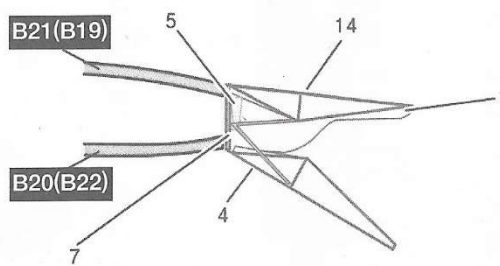

※ do not use wire.  
와이어는 사용하지 않습니다.

painting & decal placement / 색칠 및 전사지불이기

ver.1  
버전1

SB2C-4E, VB-16 USS Randolph, 1945

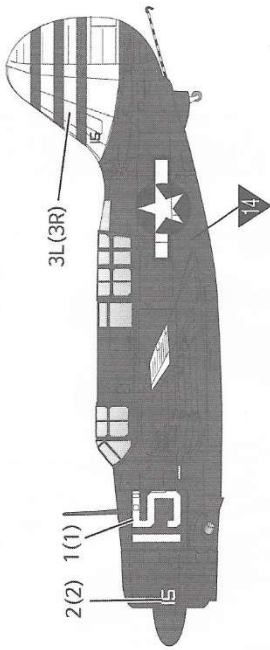

<Top/상면>

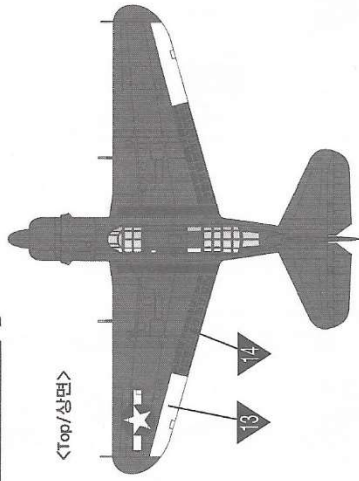

<Bottom/하면>

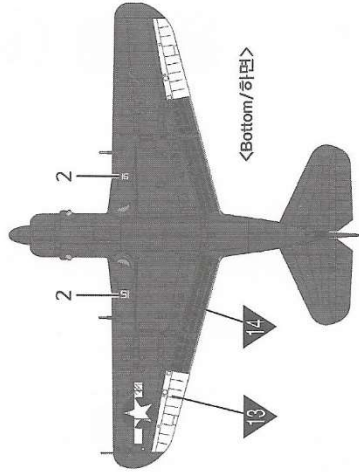

ver.2  
버전2

SB2C-4E, VB-84 USS Bunker Hill, 1945

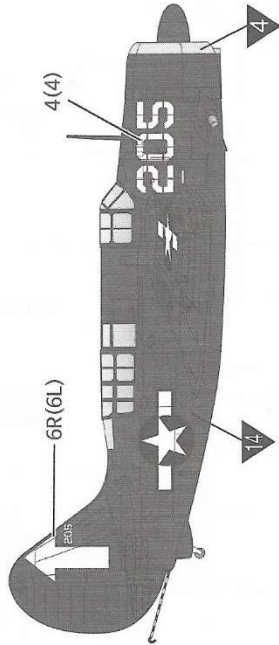

<Top/상면>

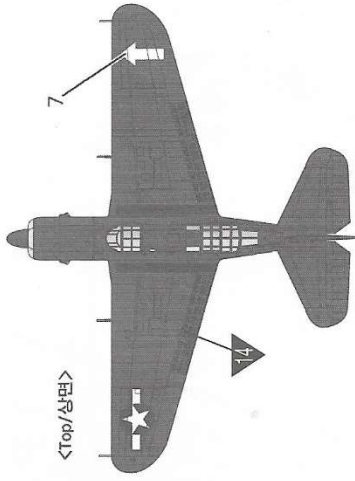

<Bottom/하면>

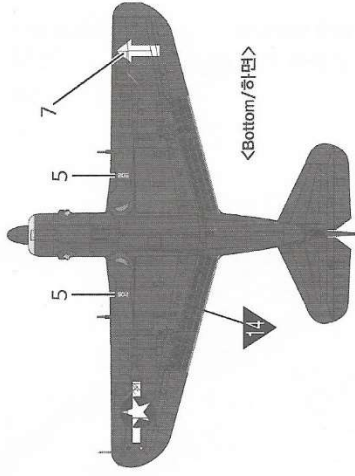

ver.3  
버전3

SB2C-4, "White" VB-3 USS Yorktown, April 1945

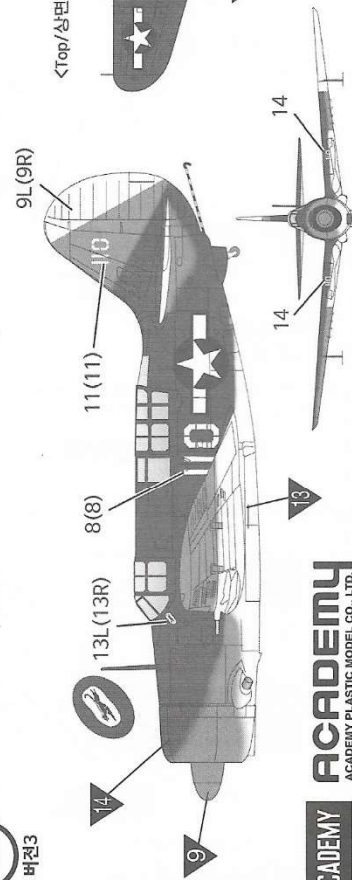

<Top/상면>

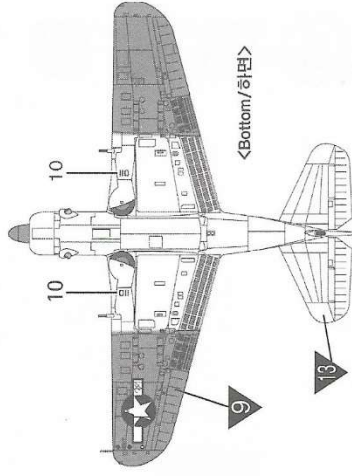

<Bottom/하면>

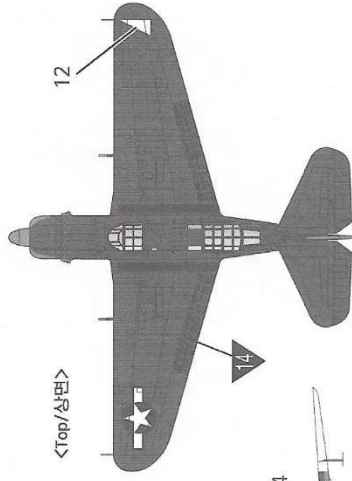

**ACADEMY**  
ACADEMY PLASTIC MODEL CO., LTD.  
HOBBY MODEL KITS