

F-16 FIGHTING FALCON



Read before assembly.

组装前敬请
详细阅读。



Please get the useful tools ready. Remove parts from frame with a pair of scissors and trim away excess plastic. Do not pull off parts. Use cement sparingly to avoid damaging the model. Please tear the plastic bag of this product to avoid children putting their heads into the bag. Do not put the parts into your mouth.

使用工具應小心，注意安全。用模型剪從注塑片中取出零件，修去多余料頭及飛邊，勿拔取零件。使用模型膠勿過量，不得近火源。商品的空袋為了不讓小孩套在頭上請撕毀。禁止把零部件含入口中。



Cement parts
用膠粘接



Do not cement
不用膠水粘接



Cut away
割去



Caution
特別注意



Ballast(not included)
壓倉物(本品不包括)



Optional parts
可選的部分



Repeat operation
重複操作



Stick decal
貼上水貼紙

1

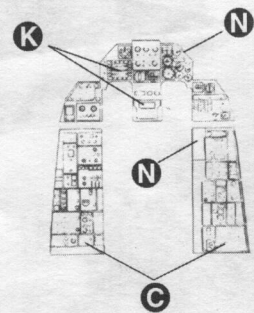
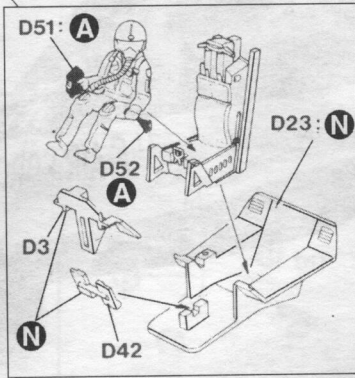
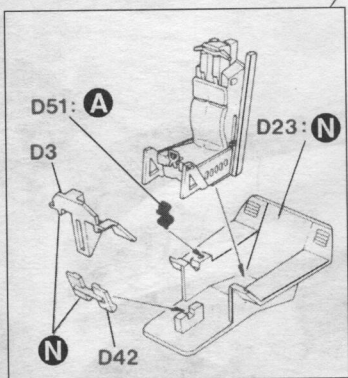
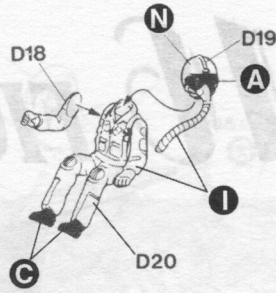
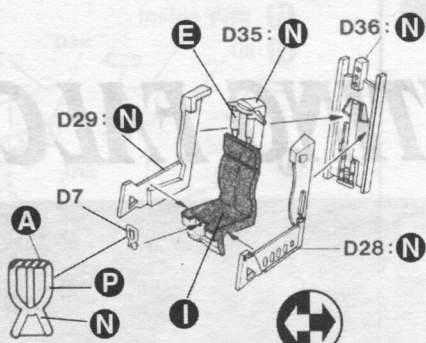

2

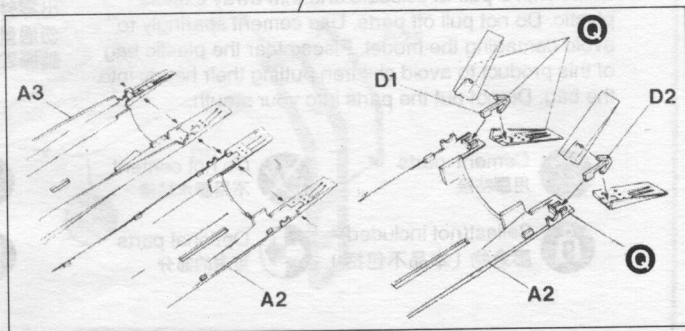
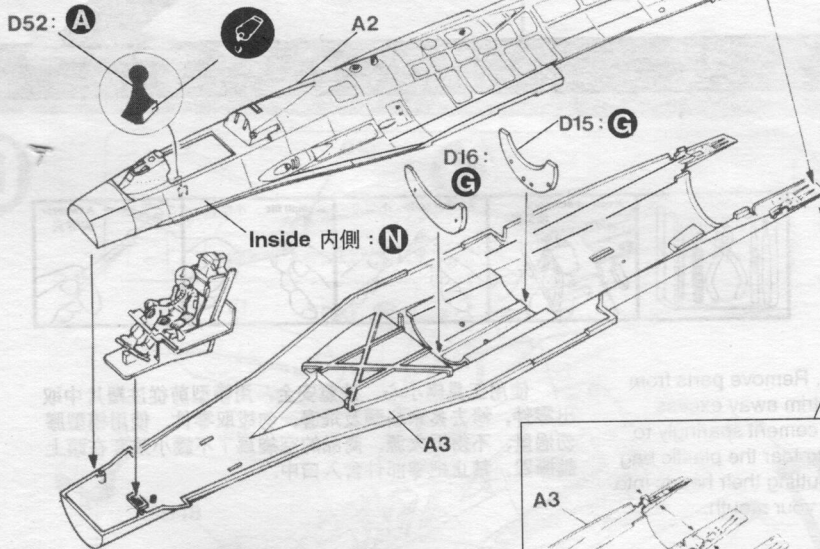

3

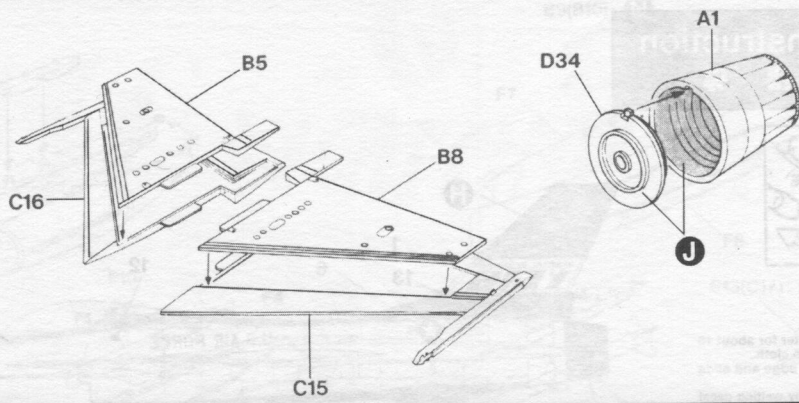

4

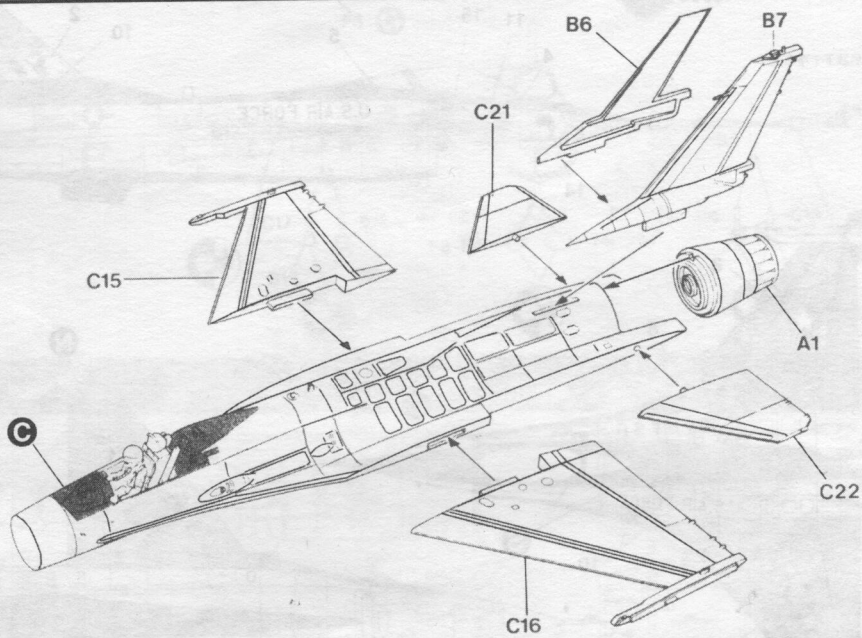

5

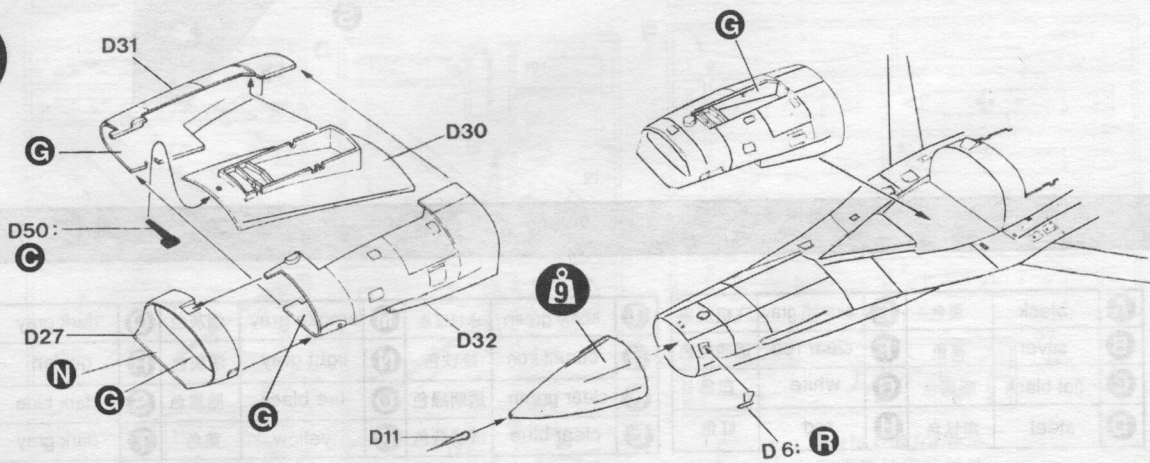

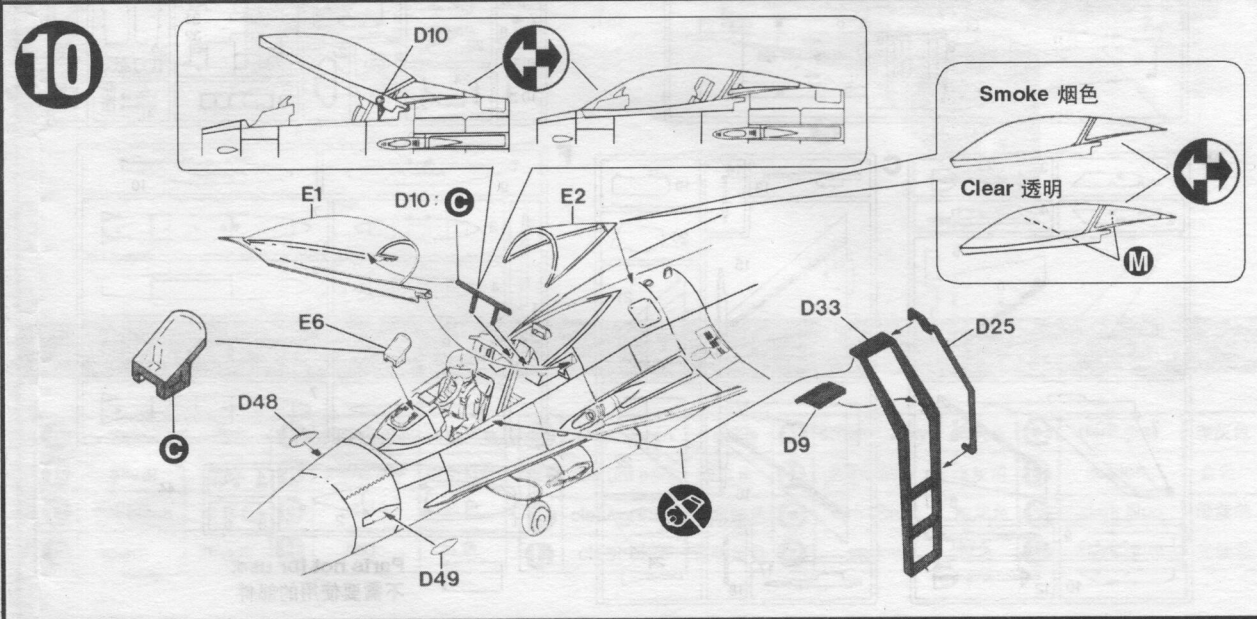
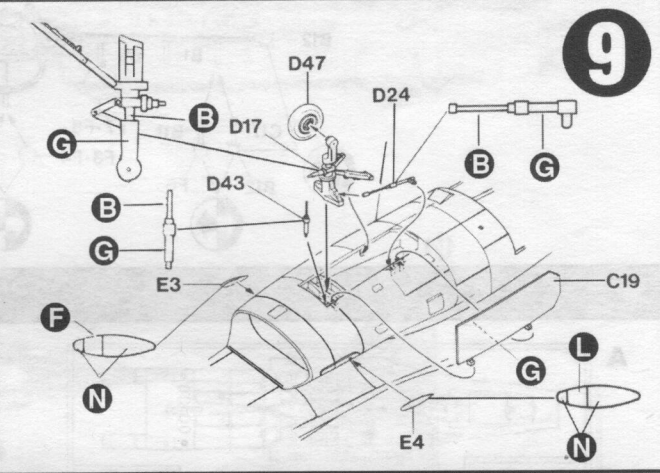
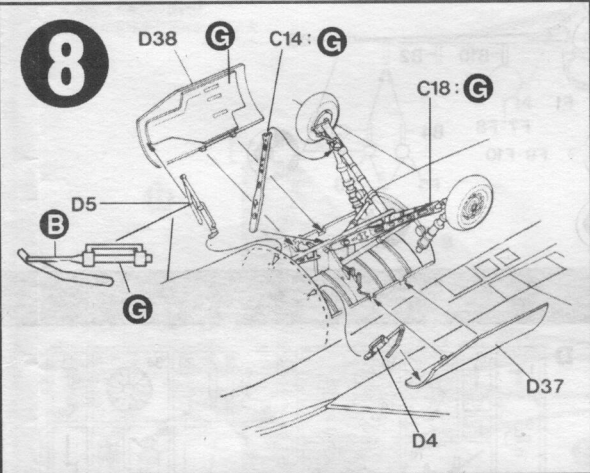
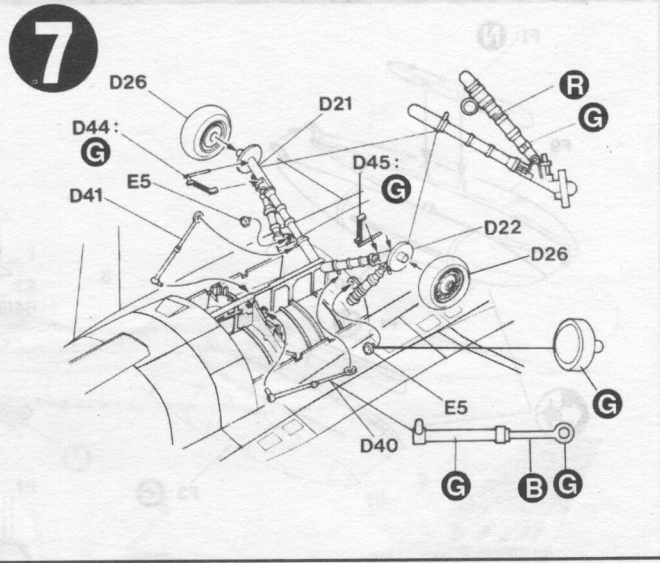
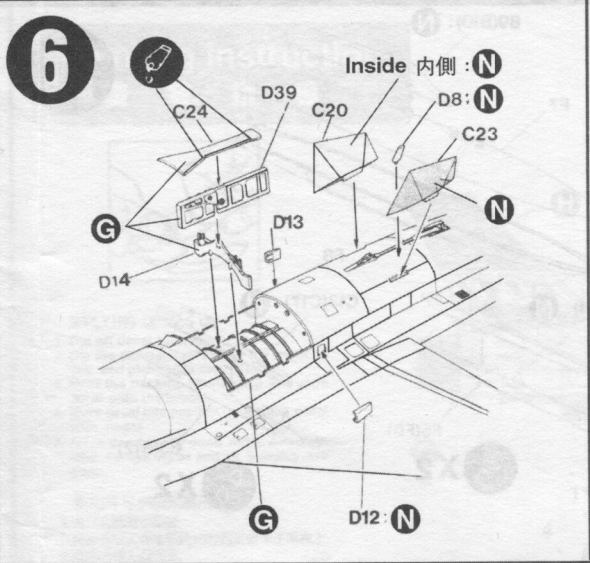

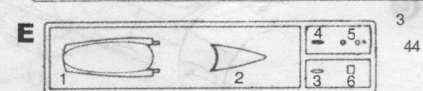
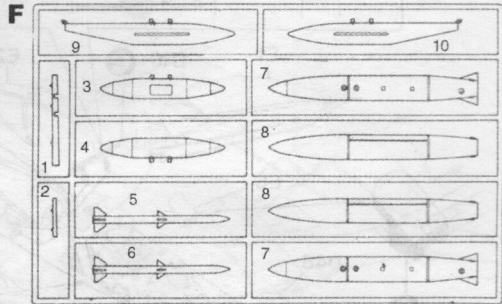
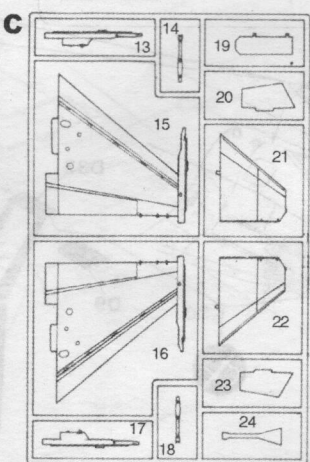
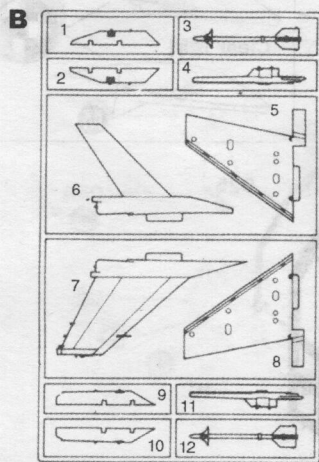
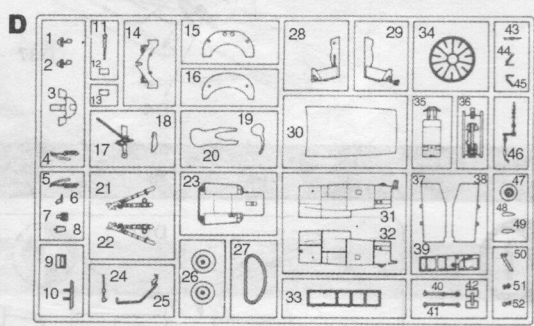
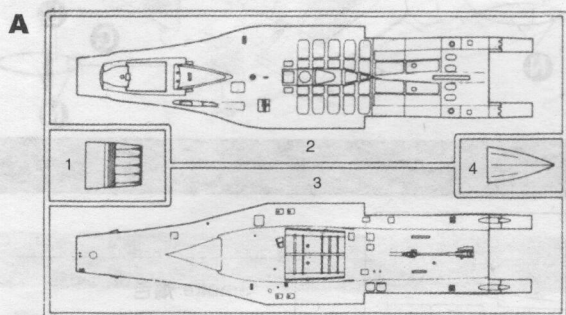
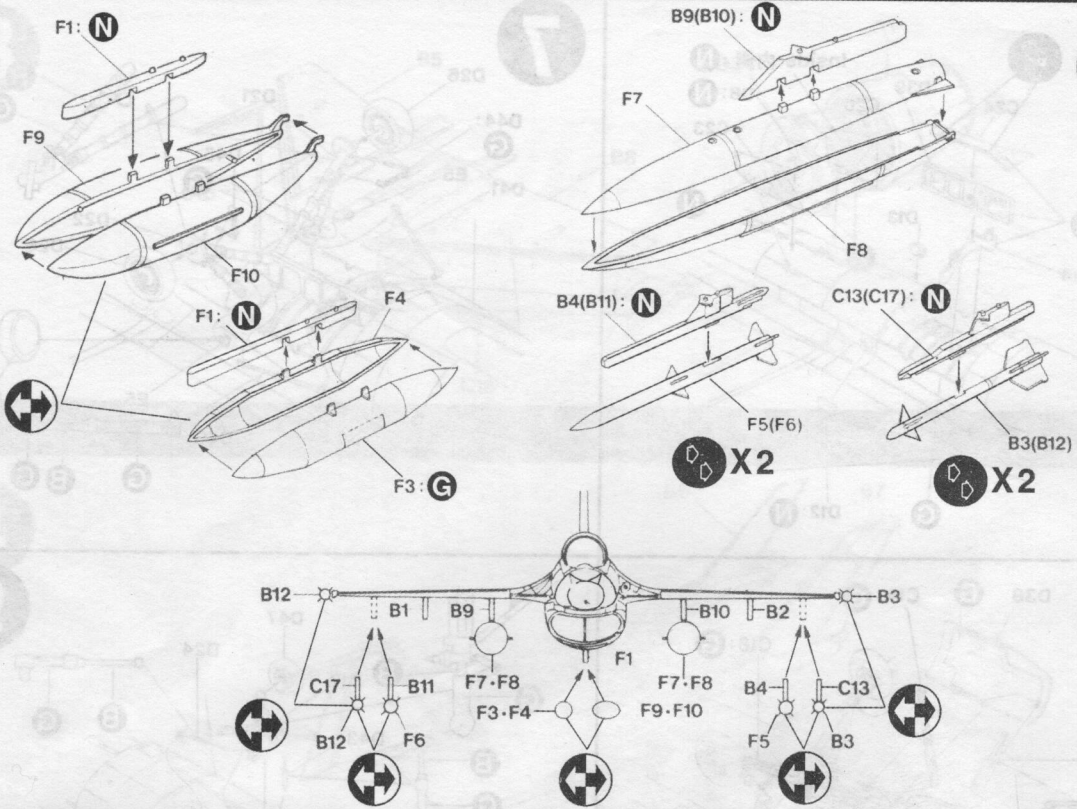

Parts not for use.
不需要使用的部件

Painting instruction

塗裝指導



APPLYING DECALS

1. Cut off decal from sheet.
2. Dip the decal in tepid water for about 10 sec and place on a clean cloth.
3. Hold the backing sheet edge and slide decal onto the model.
4. Move decal into position by wetting decal with finger.
5. Press decal gently down with a soft cloth until excess water and air bubbles are gone.

印花(印花水貼紙)應用

1. 由印花紙剪下印花
2. 將印花放入溫水中約10秒然後放於乾淨布上
3. 將印花移入模型上
4. 手指沾水移放印花到位
5. 用軟布輕輕壓印花直到水泡消失

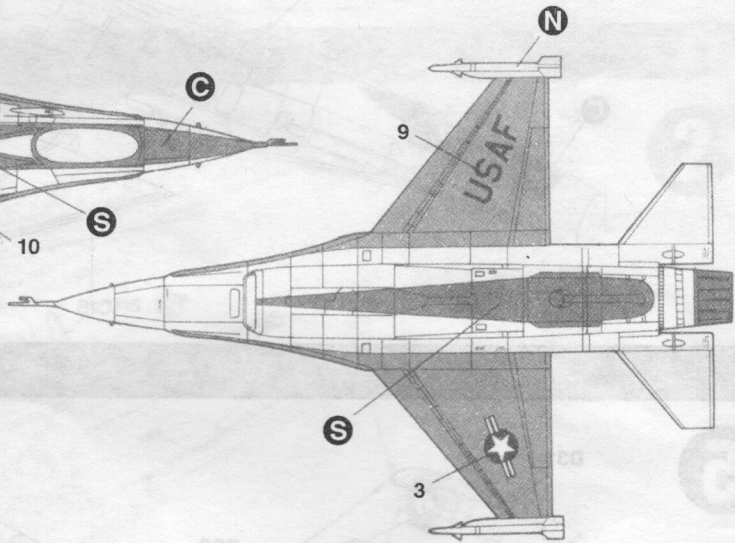
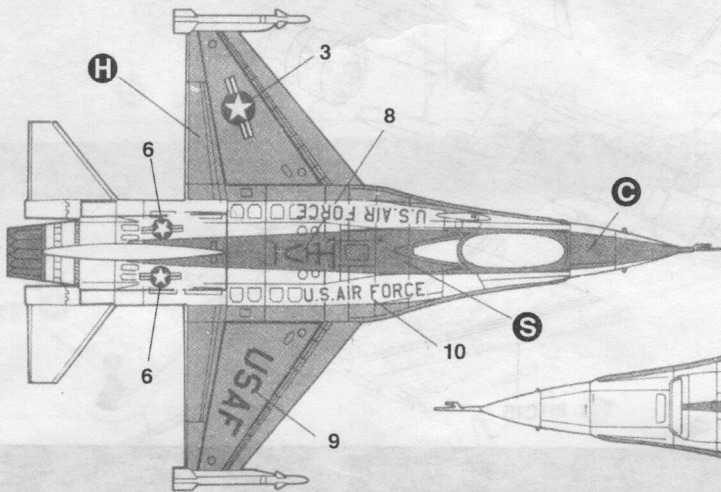
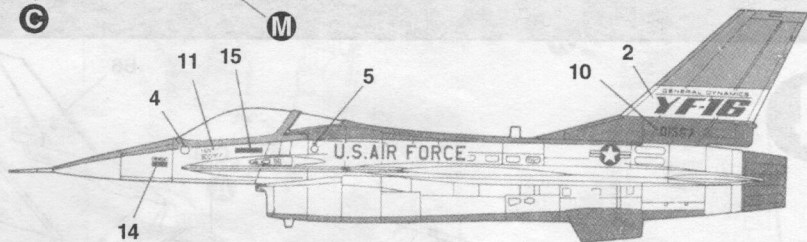
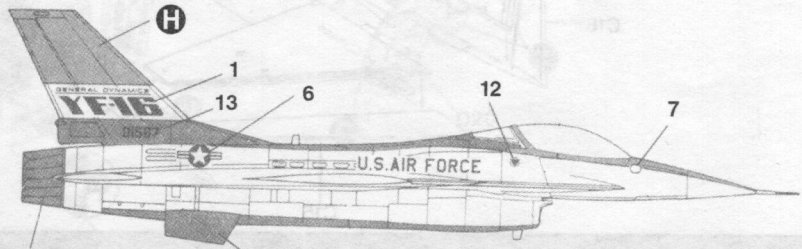

A	black	黑色	E	aircraft gray	飞机灰色	I	khaki green	卡机绿色	M	smoke gray	烟灰色	Q	dark gray	深灰色
B	silver	银色	F	clear red	透明红色	J	burnt iron	烧铁色	N	light gray	浅灰色	R	golden	金色
C	flat black	哑黑色	G	white	白色	K	clear green	透明绿色	O	tire black	胎黑色	S	dark blue	深蓝色
D	steel	黑铁色	H	red	红色	L	clear blue	透明蓝色	P	yellow	黄色	T	dark gray	光蓝色