

# Digital 1/48

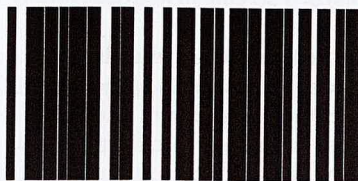

OMD1083



## RNZAF Corsairs – Pacific other than Bougainville 1943-45

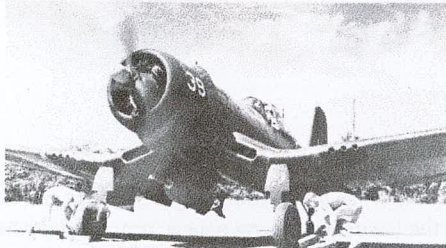

Goodyear F4U-1D, NZ5471, probably of No 3 SU, Los Negros August-September 1945. Colour is "US Navy Glossy Sea Blue". R.106 on fuselage and R.106 on wings. Finflash—FF3. Serial number and step indicator line—White. Propeller dome—Black. Note the lack of framing in the upper portion of the sliding canopy when compared with the earlier F4U-1 above, also the underlying rocket launching struts.

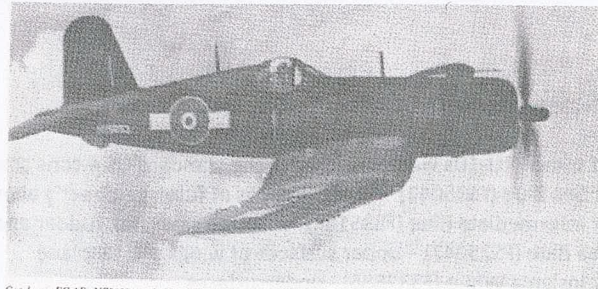

Goodyear F4U-1D, NZ5653, probably of No 3 SU, Los Negros August-September 1945. Colour is "US Navy Glossy Sea Blue". R.106 on fuselage and R.106 on wings. Finflash—FF3. Serial number and step indicator line—White. Propeller dome—Black. Note the lack of framing in the upper portion of the sliding canopy when compared with the earlier F4U-1 above, also the underlying rocket launching struts.

The decals were fitted to a 1/72 kit I have and scaled as appropriate for other scales.

### Background

The RNZAF operated 424 Corsairs during WWII with the survivors being stored shortly thereafter and then 24 were reactivated for service with 14 Sqn in Japan (1946-48).

### This decal set

This set is meant to attempt to cover the Servicing Units (SUs) and Sqns based in the Pacific except those based in Bougainville area during WWII.

The RNZAF used some 15 different variants of roundels on Corsairs during WWII, and three variations on the fin flashes. They have been identified on the decal sheet as A-O for the roundels and X-Z for the fin flashes.

The following matrix is designed to assist with known combinations and general notes on other decal options. There are five examples provided.

	Aircraft Type	Unit	Location	Date	Upper Wing Roundel	Lower Wing Roundel	Fuselage Roundel	Fin Flash	Paint Scheme	Notes
1	F4U-1	5 SU	Los Negros	1945	A	A	G	X	Glossy Sea Blue	
2	F4U-1	31 SU / 14 Sqn	Espiritu Santo	1944	B	B	L	Z	RP3	Last 2 digits of registration on cowl in white
3	F4U-1D	3 SU	Jacquinot Bay New Britain	1945	D	B	L	Z	RP5	Last 2 digits of registration on cowl in white And on undercarriage legs in black
4	F4U-1	3 SU	Jacquinot Bay New Britain	1945	B	B	J	Z	RP8	Large last 2 digits of registration on fuselage side in white. Upper forward tail fin in orange-yellow.
5	F4U-1D	5 SU / 19 Sqn	Emirau	Nov 1944	B	B	K	Z	RP7	Last 2 digits of registration on cowl in white

Some aircraft also had white tape sealing the nose area. This has been provided. Known to have been present on the two F4U-1D options.

The following unit motifs were carried by aircraft as follows:

23 Sqn – Ghost motif (many but not all carried this)

2 SU – Two "saint like" figures carried by some aircraft at Bougainville (eg NZ5471 "471")

4 SU – Little Devil motif (examples include NZ5228 "28" "D", NZ5253 "35" "O", NZ5310 "10" "I", NZ5395 "95" "G")

An irate Donald Duck motif was carried by a number of aircraft (this was a common USN motif). Examples include NZ5255 "55" "C" of 4 SU, NZ5248 "48" and NZ5277 "77" of 30 SU.

Individual aircraft motifs include:

"KOHIMARAMA IX" (with Heitki and Ghost Sqn motifs) of 5 SU Emirau and Bougainville 1945

"STRUGGLE BUGGY" – NZ5350 of 31 SU Espiritu Santo 1944

"NAN" with bomb symbols – NZ5424 "24" of 3 SU Nissan Island, Green Islands and Jacquinot Bay 1945

"LIL AUDREY" – NZ5440 "40" of 3 SU Nissan Island, Green Islands and Jacquinot Bay 1945

"PATRICIA MARY" – NZ6557 "57" of 3 SU Nissan Island, Green Islands and Jacquinot Bay 1945

"MY OLD BRAVE" – NZ5??? of 3 SU Nissan Island, Green Islands and Jacquinot Bay 1945

I have also provided a set of kill markings that includes the usual Japanese flag aircraft kill markings, two sizes of bombs, trucks and 2 sizes of ships (these were sourced from USAF/USN Pacific markings sets).

A full set of small markings are provided as well as step markings in two colours (right hand side of fuselage) and walkways. Use as you see fit.

#### **Painting.**

There are at least ten known schemes carried by RNZAF aircraft.

All F4U-1 and some F4U-1Ds were delivered in the standard US 4-tone scheme of:

Non Specular Sea Blue (FS35042) - upper surfaces of fuselage directly above the wing, and leading edges of wings and tailplane;

Non Specular Intermediate Blue (FS35164) - fuselage sides, fin, rudder and the lower outer wing panels, propeller spinners.

Semi Gloss Sea Blue (FS25042) – upper surfaces of wings and tailplane

Non Specular Insignia White (FS37886) - undersurfaces

Later F4U-1Ds and all FG-1Ds were delivered in the US Glossy Sea Blue scheme of overall Glossy Sea Blue (FS15042) with a matt anti-glare panel on the upper nose of FS35042).

Researchers have identified at least 8 distinct NZ applied repaint schemes.

The first 2, we shall call RP1 and RP2 consisted of a single colour upper surfaces and fuselage sides, plus the underside of the outer wings, and a lighter colour on all other underside surfaces.

For both RP1 and RP2 the upper surface was one of NZ Ocean Blue, NZ Medium Blue, Non Specular Blue Grey (FS36118) or Non Specular Intermediate Blue (FS35164)

For RP1 the underside was Non Specular Insignia White (FS37886) and the spinners black. For RP2 this was either Non Specular Light Grey (FS36440) or NZ Light Grey, the spinners were Glossy Orange Yellow (FS13538)

RP3 to RP8 were variations on the US Glossy Sea Blue scheme with the following recorded variances. Unless otherwise stated undersides do not include the outer wing panels.

RP3 – the underside outer wing panels were Non Specular Intermediate Blue (FS35164). The spinners were Glossy Orange Yellow (FS13538)

RP4 – the underside, including all the wing underside, was NZ Duck Egg Blue. Spinners were black.

RP5 - the underside outer wing panels and the underside of the tail planes were Non Specular Intermediate Blue (FS35164). Spinners were black.

RP6 –the underside and spinner was Non Specular Insignia White (FS37886). The front portion of the engine cowl was Glossy Engine Grey (FS16081).

RP7 - was Glossy Sea Blue (FS15042) all over (no anti glare panel). The spinners were Glossy Orange Yellow (FS13538)

RP8 – as for RP7 except the undersides of the fuselage, the inner most portion of the wings (to where the wing bends back up) and the tail planes were US Light Grey (FS36440). Spinners were white.

Hope these comments are of help.

As always, remember this is a hobby and ENJOY!

John

©Oldmodels Berals

18 October 2016

### GOODYEAR FG-1D CORSAIR

Glossy Sea Blue overall

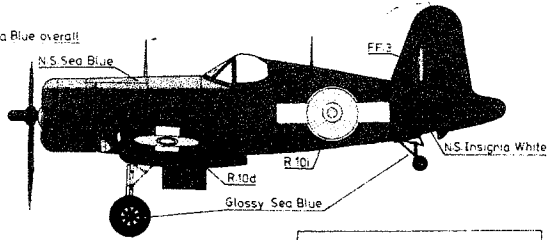

FG-1D, NZ5653, No 5 SU(7), Los Negros, 1945.

### US NAVY GLOSSY BLUE SCHEME

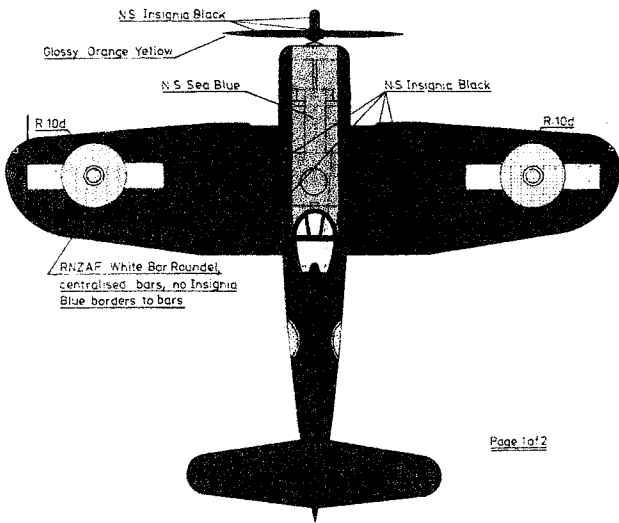

Page 1 of 2

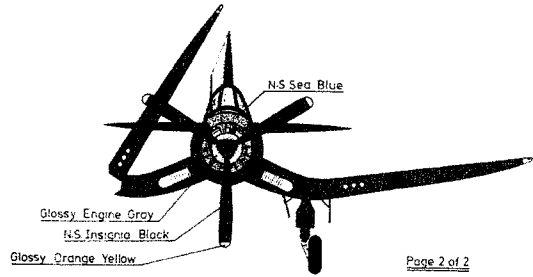
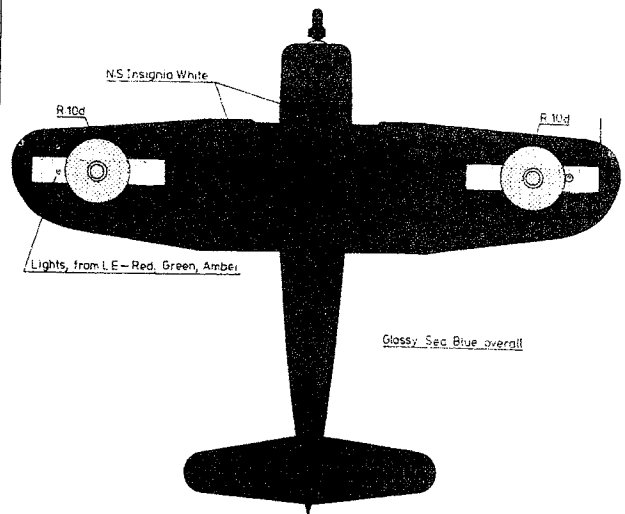

Page 2 of 2

WPR

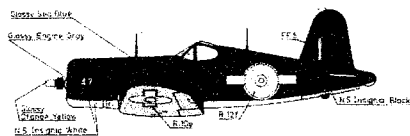
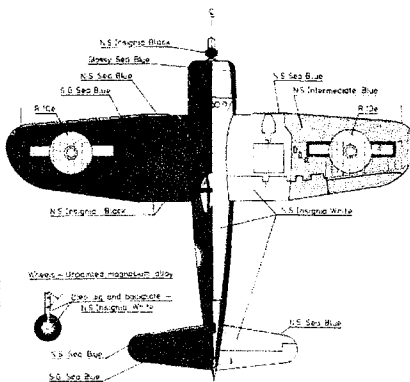

Fig 1, NZ5247, No 15 SQ, No 21 SQ, Esplanade, Scone, New Ireland, 1945.

re-paint scheme 3



2

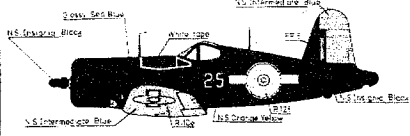
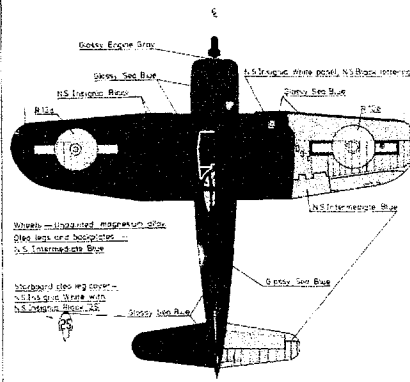

Fig 10, NZ5475, No 7, No 15 SQ, Esplanade, Scone, New Ireland, 1945.

re-paint scheme 5



3

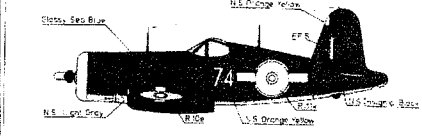
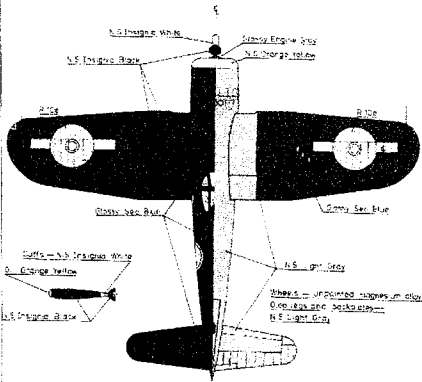

Fig 1, NZ5247, No 15 SQ, No 21 SQ, Esplanade, Scone, New Ireland, 1945.

re-paint scheme 8



4

For scheme 5 see the right hand photograph on page 1.

**RNZAF Corsairs**  
**Stencil placement sheet**

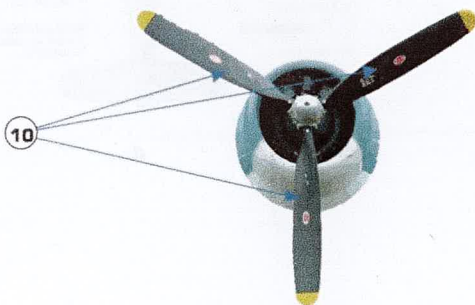
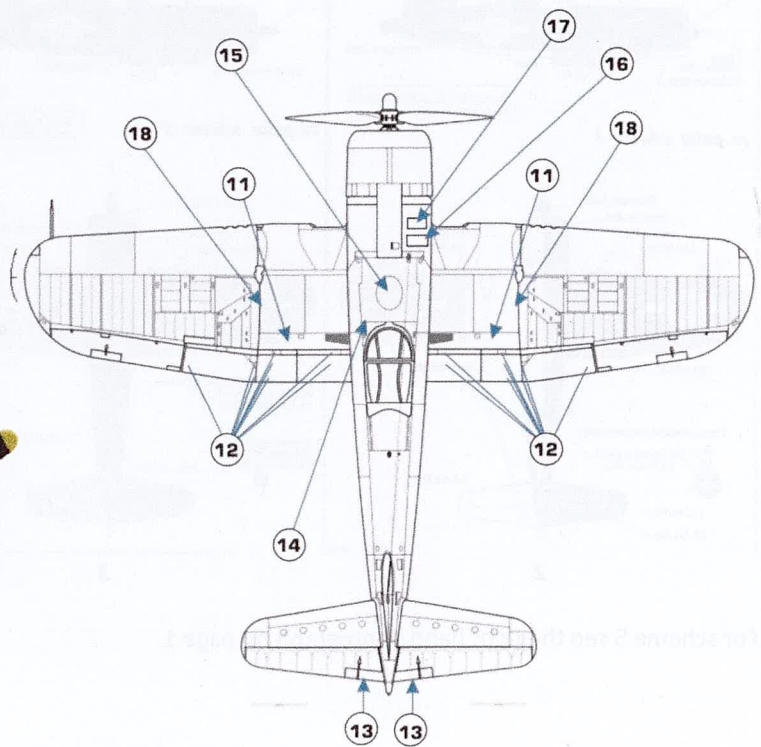
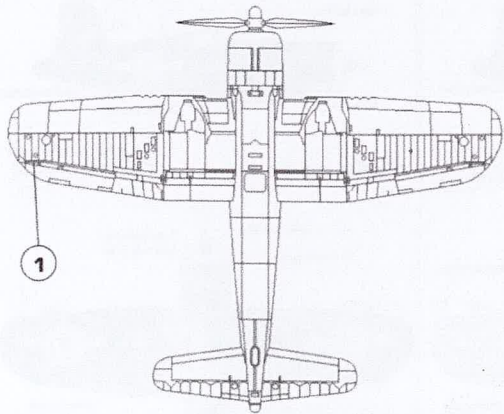
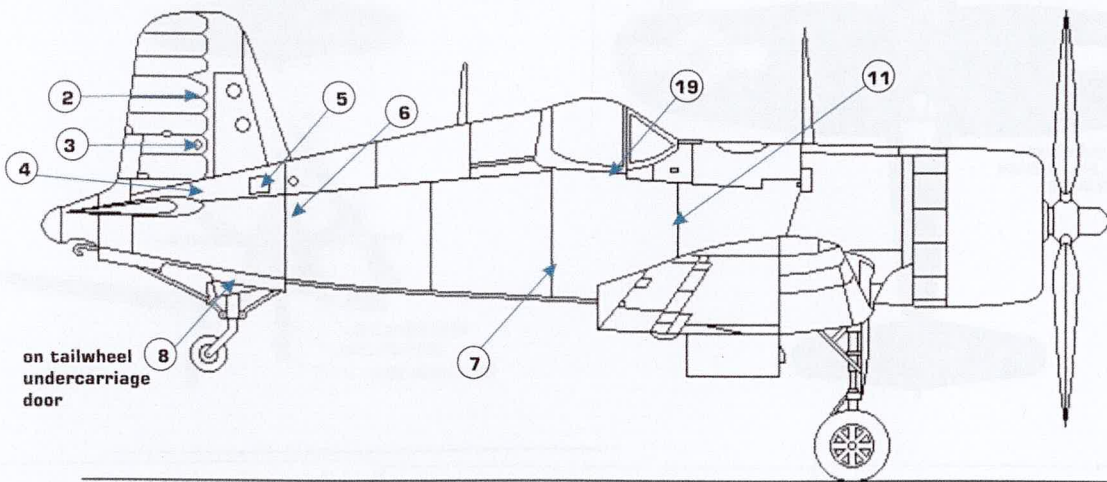
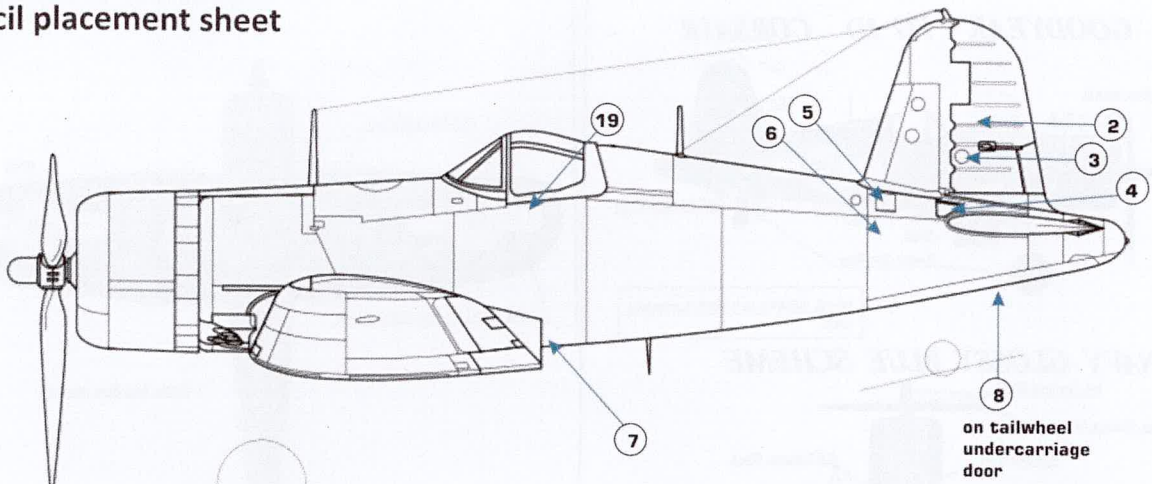

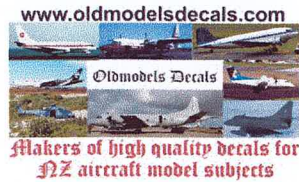

## PLEASE READ THIS BEFORE COMMITTING THE DECALS TO WATER

These instructions on decal preparation are generic and use apply to most decal brands.

**These decals are a continuous sheet.** Therefore you need to cut out around each decal. Digital decals will also stand being cut into pieces – this may help with large decals.

**The backing stock (the clear areas) tend to be very thin.** This may also be the case with **dark colours**. Experiment with spare bits, an overcoat of gloss/satin/matt clear coat maybe appropriate.

On the other hand some **white and light coloured** decals printed before April 2016 tend to be quite **thick** – this is caused by the white ink that needs to be thick to avoid “see through” opacity when applied over dark paint. This can make the decals difficult to bend and contour to the model. The use of Microsol or DACO or other brand similar products is recommended.

**Please note that most decal stock do not like being over-soaked.** Dip them just enough to become wet, remove and leave for a minute or so until they slide off. **If over soaked they may lose their “stickiness”.** If this happens the use of Microset or DACO or other brand similar products is recommended.

Generally there are extra bits and/or options on most sheets – I suggest you play around with them and then do the “real” decal application.

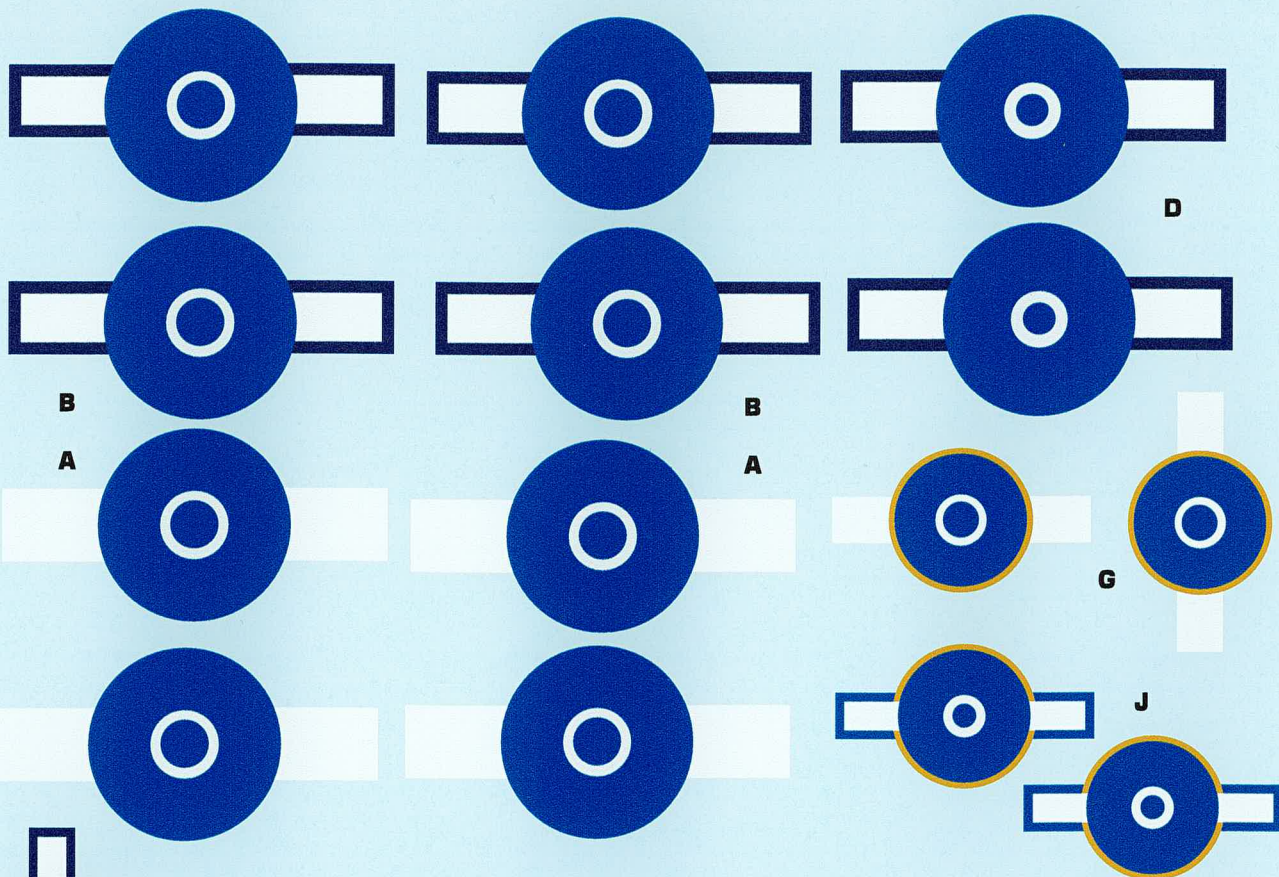

01 122333444555667788990  
 01 122333444555667788990

NZ520I 1122333444555667788990  
 NZ520I 1122333444555667788990  
 01 122333444555667788990  
 01 122333444555667788990

01 122333444555667788990  
 01 122333444555667788990

*Patricia Mary*

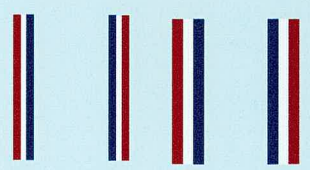

X

Z

12

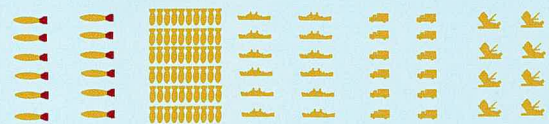

MY OLD BRAVE

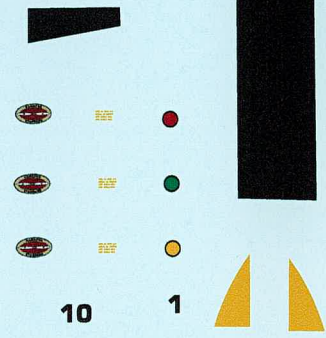

10

1

STRUGGLE BUGGY

LIL AUDREY

KOHIMARAMA IX

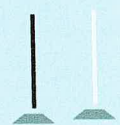

TUTAEWERA

*Nan*

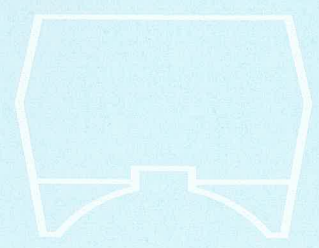

2 3 4 5 6 7 8 11 13

