

*"The Tomahawk's first victories"*

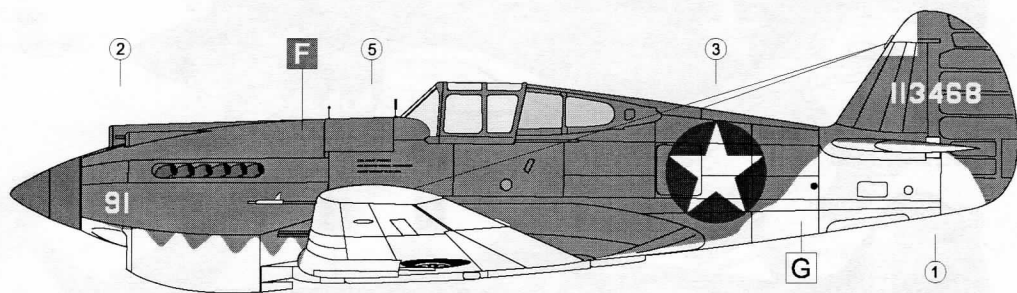

*P-40C, s/n 41-13468, 31st FS, 6th AF, Carribean, December 1942.*

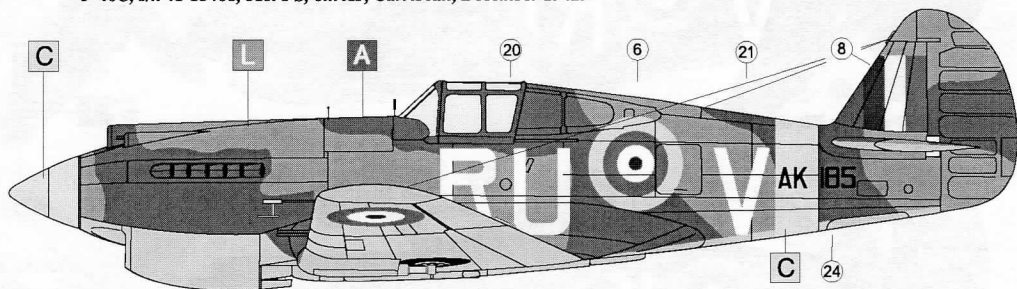

*P-40 Tomahawk Mk.IIB, AK 185, 414.Squadron RCAF, England, October 1941.*

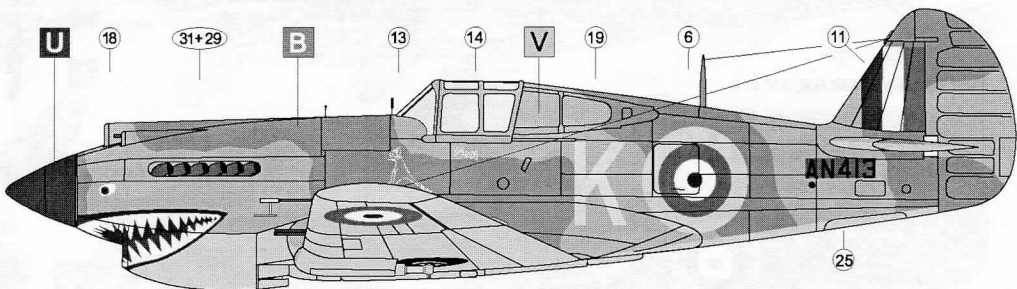

*P-40 Tomahawk Mk.IIB, AN 413, 112.Squadron, Sidi Hanneish, November 1941, flown by Plt. Off. J.Bartle, officially 4 kills and 1 probable victory on this Tomahawk.*

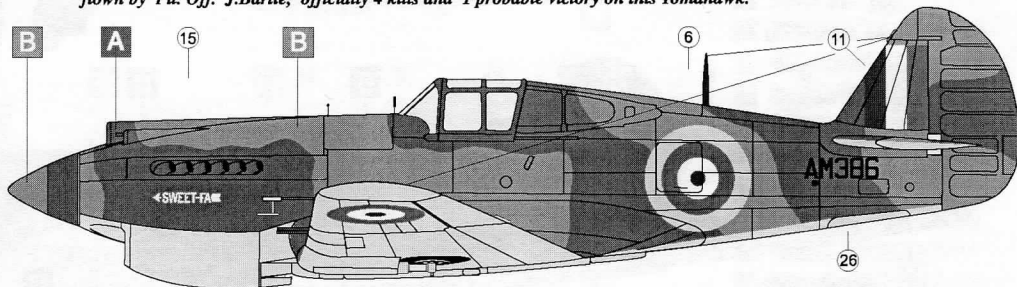

*P-40 Tomahawk Mk.IIB, AM 386, 3.Squadron RAAF, Palestina, August 1941, flown by Flt. Lt. A. Rawlinson, officially 5 kills and 1 probable victory on this Tomahawk.*



## Doporučené barvy

<i>Recommended Colours</i>	<i>F.S.</i>	<i>Humbrol</i>	<i>Gunze Sangyo</i>	<i>Model Master Enamel</i>	<i>Agama</i>
<b>A</b> Dark Green	4079	H 116	73	1710	B1M
<b>B</b> Dark Earth	0118	H 142	72	1702	B2M
<b>C</b> Sky	4504	H 90	74		B5M
<b>D</b> Medium Sea Grey	6307	H 165		1725	B6M
<b>E</b> Neutral Grey	6270	H 176	53		A3M
<b>F</b> Olive Drab	4087	H 155	52	1711	A2M
<b>G</b> White	7875	H 34	11	1768	O1M
<b>I</b> Black	7038	H 33	12	1749	07
<b>J</b> Yellow	3538	H 188	329	1790	N20M
<b>K</b> Aluminium		H 56		1781	
<b>L</b> Ocean Grey	6152	H 106			B3M
<b>M</b> Gunmetal		H 53			32
<b>N</b> Interior Green	4151	H 151	58	1715	
<b>O</b> Rust		H 113	344		29
<b>P</b> Silver	7178	H 11	8	1546	8
<b>R</b> Zinc Chromate Primer		H 81		1050	A11
<b>S</b> Steel Grey		H 87			
<b>T</b> Leather		H 62		1736	
<b>U</b> Red	1136	H 153	327	1705	
<b>V</b> Mid Stone	0266	H 84			B12
<b>Y</b> Azure Blue	5231	H 157			B13

NOTE: This above list references to Federal Standard /FS 595A / numbers do not include the prefix number. This just denotes the sheen of the colour e.g. 1= Gloss, 2= Semi-gloss, 3= Matt.

Barevný návod najdete na našich webových stránkách - [www.aml.cz](http://www.aml.cz)

If you want a full colour instruction sheet you can download and print from our web sites - [www.aml.cz](http://www.aml.cz)

## Doporučená literatura / References

Tomahawk and Kittyhawk Aces of the RAF and Commonwealth

The Curtiss P-40 Tomahawk , No.35

P-40 in detail, Part 1-YIP-36 trough P-40C , Vol.61

Curtiss P-40 in action , No.26

Walk Around P-40 Warhawk , No.8

Curtiss P-40

Curtiss P-40, No.64,65,66

Scale Aviation Modeller International, Vol.8, No.2/2002 , etc.

A. Thomas, Osprey a/c of the Aces, No.38

R. Wagner, Profile Publications No.35

B. Kinzey, Squadron / Signal publicatins

E. R. McDowell, Squadron / Signal publicatins

L. Drendel, Squadron / Signal publicatins

V.Ehrman, V.Roman, MBI

M. Rys, Z. Kolacha, K. Janowicz, A.J.Press

## Návod na aplikaci vodou snímatelných obtisků / How to apply Decals

1. Vystřihněte pečlivě požadovaný objekt z obtiskového aršíku.
2. Namáčejte asi 10 vteřin ve vlažné vodě, až podkladový papír nasaje dostatečně vodu.
3. Položte navlhčený obtisk na nesavý podklad a nechejte působit asi 1 minutu, až se uvolní lepidlo a obtiskem lze po podkladovém papíru lehce posouvat.
4. Umístěte obtisk i s podkladovým papírem na požadované místo na modelu. Přidržeťte obtisk pinzetou a opatrně z pod něho vytáhněte podkladový papír. Pokud se Vám nepodařilo umístit obtisk přesně na požadované místo, naneste kolem okraje obtisků štětcem trochu vody. Voda zavzlíná pod obtisk a můžete pak jemně pinzetou upravit polohu obtisku na modelu.
5. Je-li obtisk na požadovaném místě, pak ho opatrně přitiskněte jemným hadříkem tak, abyste vytlačili všechnu vodu a případně vzduchové bubliny.
6. Pro sjednocení povrchu modelu a zamezení případného pozdějšího odlepování obtisků je vhodné celý povrch modelu přelakovat vhodným průhledným lakem.

1. Cut the particular image carefully of the sheet.
2. Soak it in lukewarm water for 10 seconds.
3. Put the wet image on some non - blotting surface.
4. Place the image still on the base paper to the model. Hold the image with tweezers and remove the paper carefully. If the image is placed incorrectly, add some water to the image border using a brush. The image position can then be corrected.
5. If the image is placed correctly, press it with soft cloth to eliminate excess water and air bubbles.
6. Allow the decal to dry well.
7. We recommend to coat the model surface with your favourite varnish to achieve a uniform finish. It also helps to keep the decals in place.





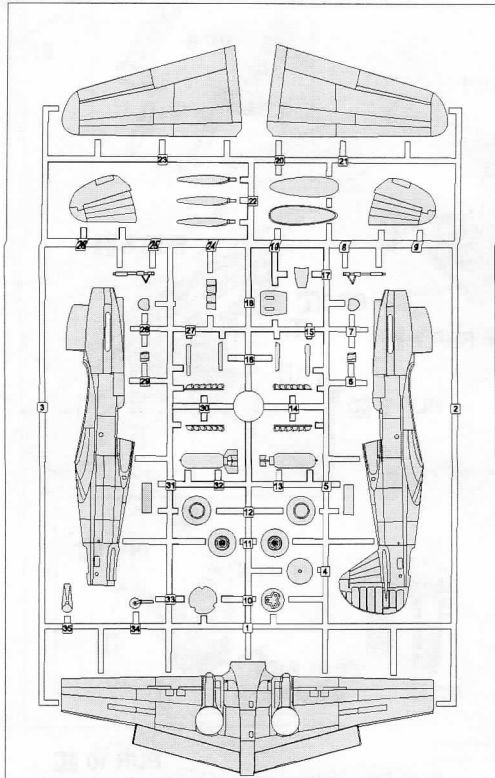

© AML 2002 The Czech Republic  
LAZAR Miroslav [www.aml.cz](http://www.aml.cz)  
Ke Studánce 1048 E-mail : [aml@aml.cz](mailto:aml@aml.cz)  
735 14 Orlová-Lutyň  
The Czech Republic Fax. ++420-069-6514487

# Parts

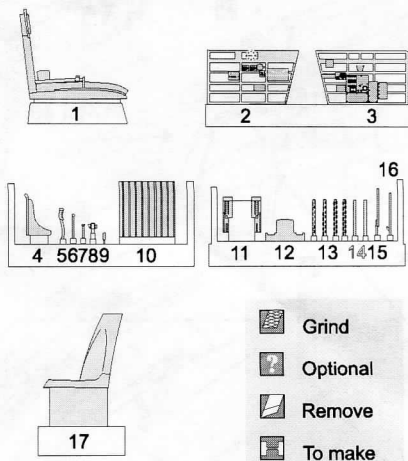

## Detail set



-  Grind
-  Optional
-  Remove
-  To make

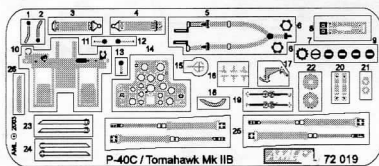

# Assembly

