

F-4E Phantom

Described as one of the fastest and most powerful combat aircraft ever created, the awesome F-4 Phantom II is an incredible fighting machine. This lethal aircraft was originally developed as a shipboard interceptor, but the brutal airwar in Southeast Asia transformed the F-4 into a versatile combat aircraft capable of handling a wide range of missions. The versatility of the Phantom has become legendary. Originally intended as a fighter interceptor, F-4's have been modified to handle the close air support, interdiction and reconnaissance missions. Initial deliveries of the Phantom began in 1961, and over a span of nearly 20 years, over 5100 aircraft were delivered to three U.S. services and ten foreign countries.

Your Revell Monogram kit represents the F-4E variation, and includes AIM 9J Sidewinder and AIM 120 AAMRAAM missiles, along with an ALQ 119 ECM POD. Decal markings are included for the 30th Anniversary "Mig Killer" F-4E of the 131st Tactical Fighter Wing in the 110th Tactical Fighter Squadron of the Missouri Air National Guard, or an F-4E of the 108th Tactical Fighter Wing in the 141st Tactical Fighter Squadron of the New Jersey Air National Guard.

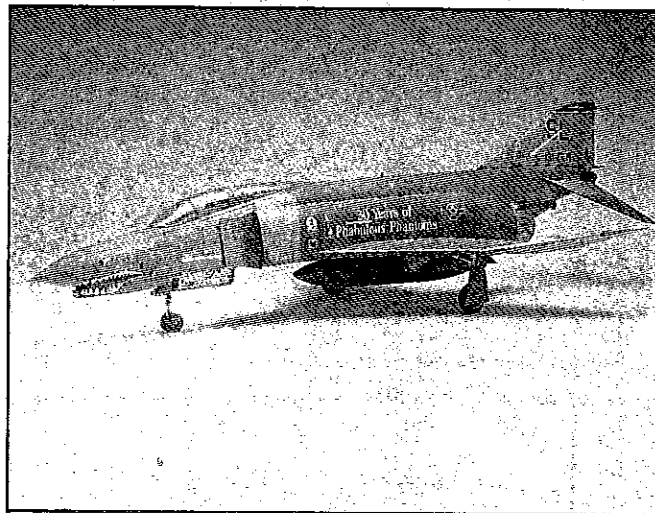

* REPEAT SEVERAL TIMES
* A REPETER PLUSIEURS FOIS



* OPTIONAL PARTS
* PIECES EN OPTION



* DECAL
* DECAL COMANIE



* ALTERNATIVE ASSEMBLY
* ENSEMBLAGE ALTERNATIVE



* CEMENT TOGETHER
* A COLLER



* REMOVE AND THROW AWAY
* A RETIRER ET JETER



* DO NOT CEMENT
* NE PAS COLLER

READ THIS BEFORE YOU BEGIN

- * Study the assembly drawings.
- * Each plastic part is identified by a number.
- * In the assembly drawings, some parts will be marked by a star (*) to indicate chrome plated plastic.
- * For better paint and decal adhesion, wash the plastic parts in a mild detergent solution. Rinse and let air dry.
- * Check the fit of each piece before cementing in place.
- * Use only cement for polystyrene plastic.
- * Scrape plating and paint from areas to be cemented.
- * Allow paint to dry thoroughly before handling parts.
- * Any unused parts may be discarded.

DECAL APPLICATION INSTRUCTIONS

(If Applicable)

1. Cut desired decal from sheet.
2. Dip decal in water for a few seconds.
3. Place wet decal on paper towel.
4. Wait until decal is movable on paper backing.
5. Place decal in position on model, face up and slide backing away.
6. Press out air bubbles with a soft damp cloth.
7. Milkiness that may appear is for better decal adhesion and will dry clear. Wipe away any excess adhesive.
8. Do not touch decal until fully dry.
9. Allow the decals 48 hours to dry before applying clear coat.

LIRE CE QUI SUIT AVANT DE COMMENCER

- * Etudier les schémas de montage.
- * Chaque pièce en plastique est identifiée par un numéro.
- * Sur les schémas de montage, certaines pièces sont marquées d'une étoile (*) pour indiquer qu'elles sont en plastique chromé.
- * Pour une meilleure prise de la peinture et des autocollants, laver les pièces en plastique avec une solution détergente peu concentrée. Les rincer et les laisser sécher à l'air.
- * Vérifier que chaque pièce s'ajuste bien avant de la coller en place.
- * N'utiliser que de la colle pour polystyrène.
- * Gratter les parties à coller pour enlever le chrome et la peinture.
- * Laisser la peinture bien sécher avant de manipuler les pièces.
- * Toute pièce inutilisée peut être jetée.

DIRECTIVES D'APPLICATION DES AUTOCOLLANTS

1. Découper l'autocollant désiré de la feuille.
2. Tremper l'autocollant dans de l'eau pendant quelques secondes.
3. Placer l'autocollant mouillé sur une serviette en papier.
4. Attendez que l'autocollant puisse être déplacé sur son support en papier.
5. Mettre l'autocollant en position sur le modèle face sur le dessus et faire glisser le support pour l'enlever.
6. Appuyer avec un chiffon doux humide pour éliminer les bulles d'air.
7. La substance laiteuse qui peut apparaître est destinée à améliorer l'adhésion de l'autocollant et devient incolore au séchage. Essuyer pour enlever tout excédent d'adhésif.
8. Ne pas toucher l'autocollant tant qu'il n'est pas bien sec.
9. Laisser l'autocollant sécher pendant 48 heures avant d'appliquer une couche transparente.

This paint guide is provided to complete this kit as shown on the box.

Ce guide de peinture est fourni pour reproduire le modèle réduit qui apparaît sur la boîte.

Satin Black	Noir satin
Silver	Argent
Yellow	Jaune
Titanium	Titane
Blue	Bleu
Dark Gray	Gris foncé
Dark Green	Vert foncé
Desert Tan	Havane de sertique
Flat Black	Noir mat
Flat White	Blanc mat
Green	Vert
Gunship Gray	Gris foncé
Medium Gray	Gris moyen
Olive Green	Olivet
Red	Rouge

If you have any questions or comments, call our hotline at: **(800) 833-3570**
or, please write to:

Revell-Monogram Consumer Service Department, 8601 Waukegan Road, Morton Grove, Illinois 60053
Be sure to include the kit number, part number, description, your return address and phone number.

Visit our website: www.revell-monogram.com

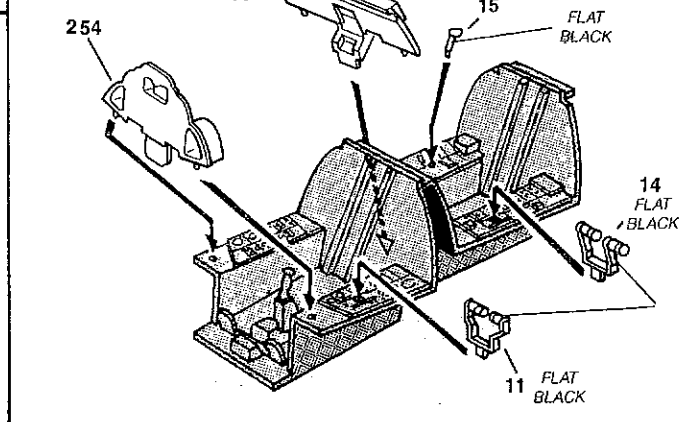
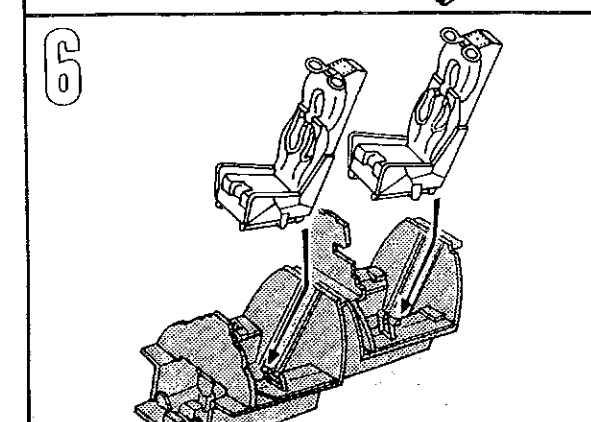
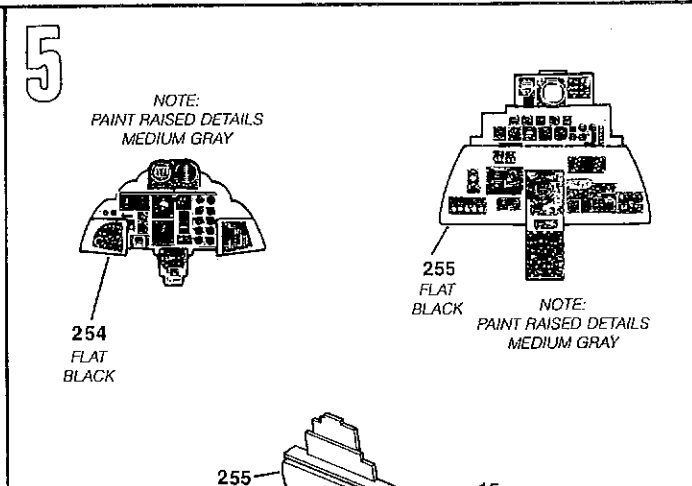
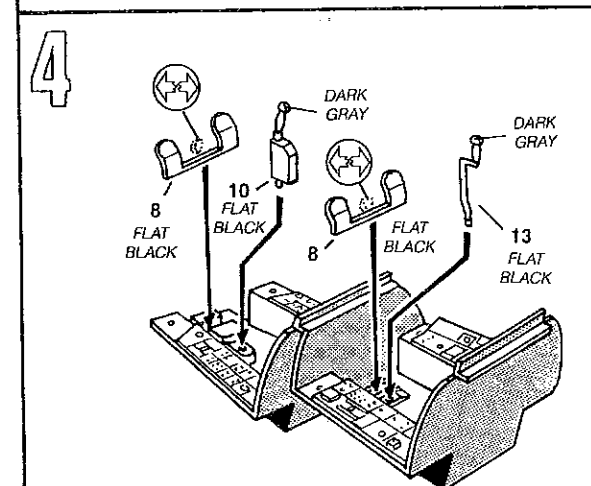
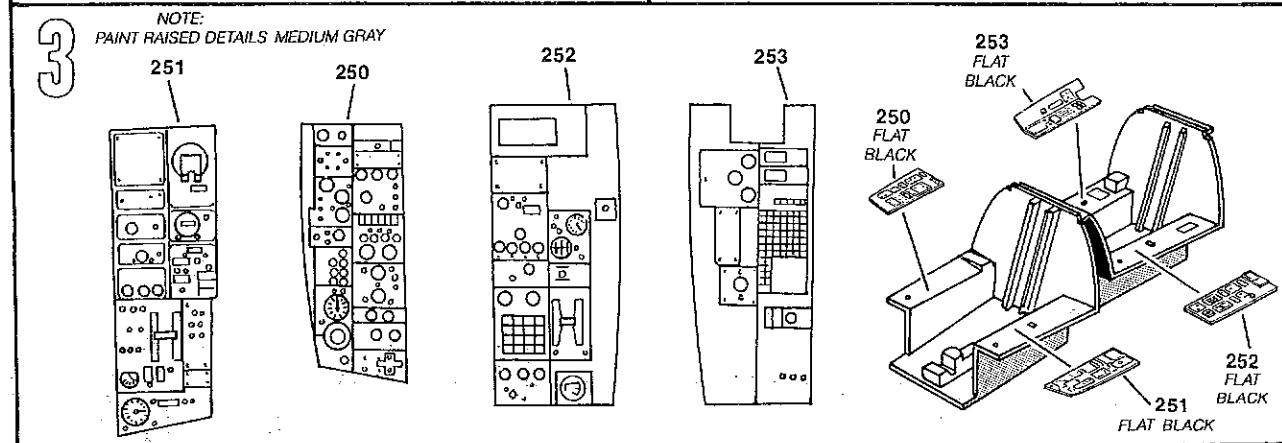
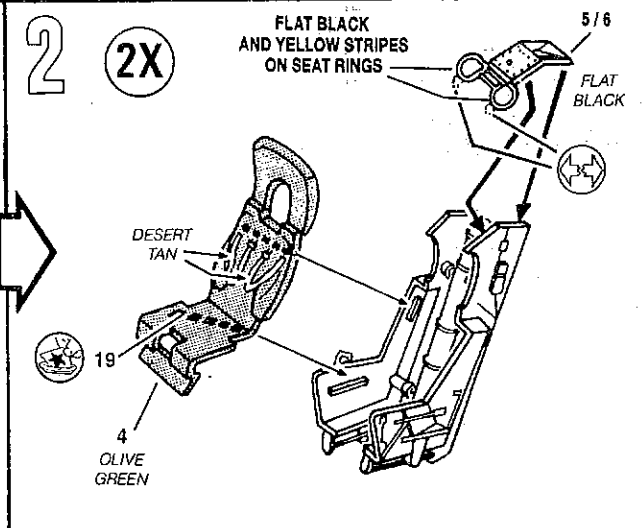
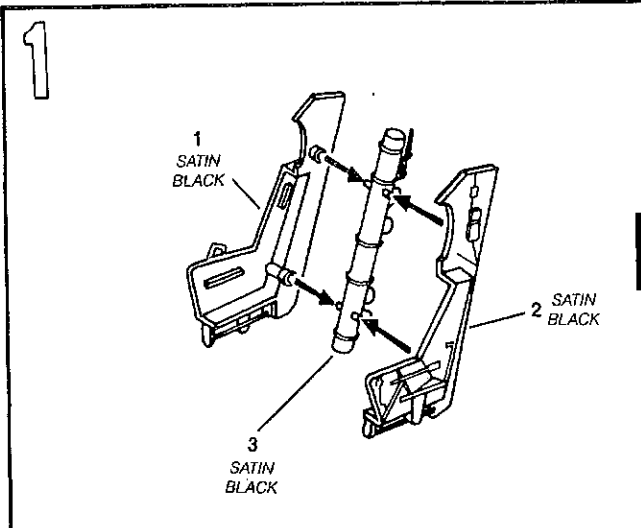

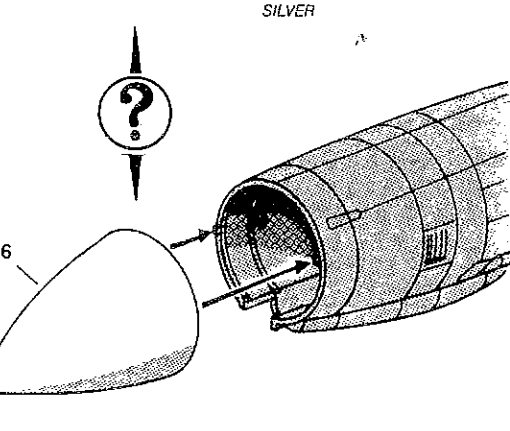
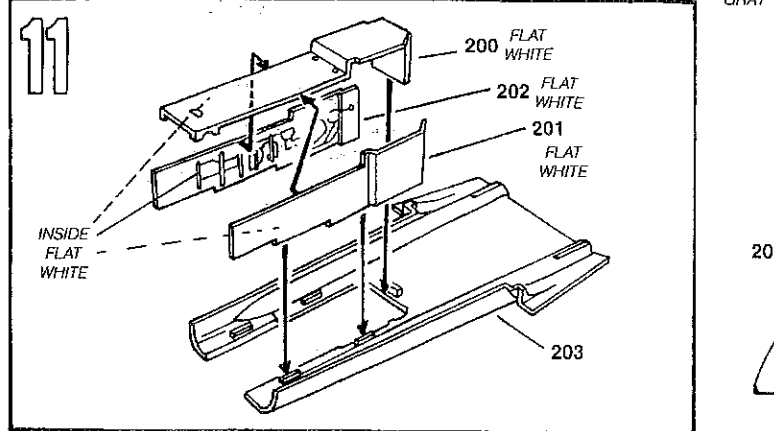
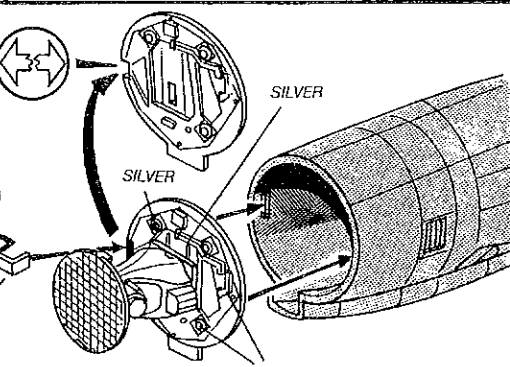
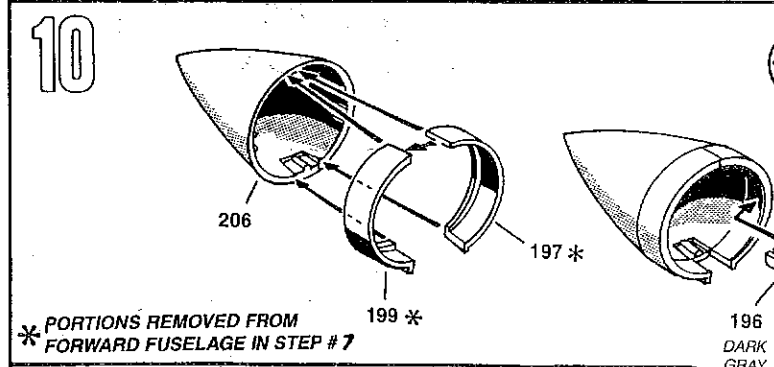
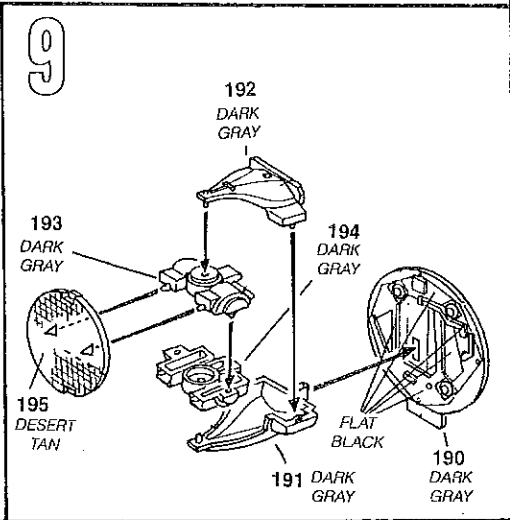
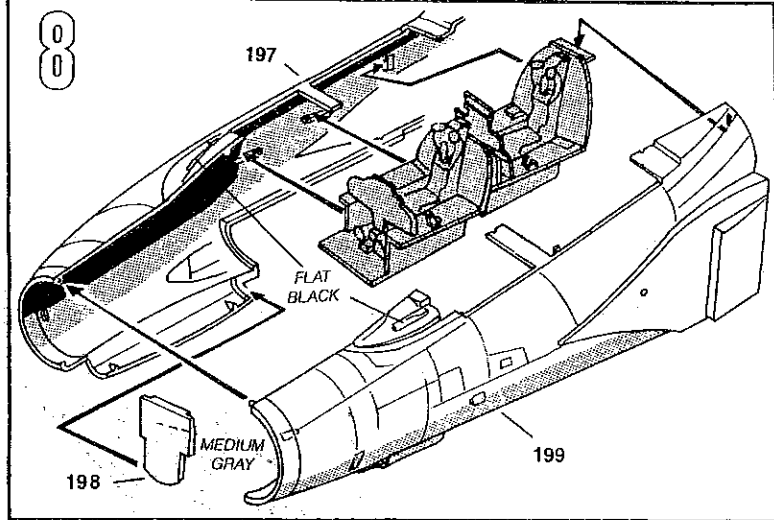
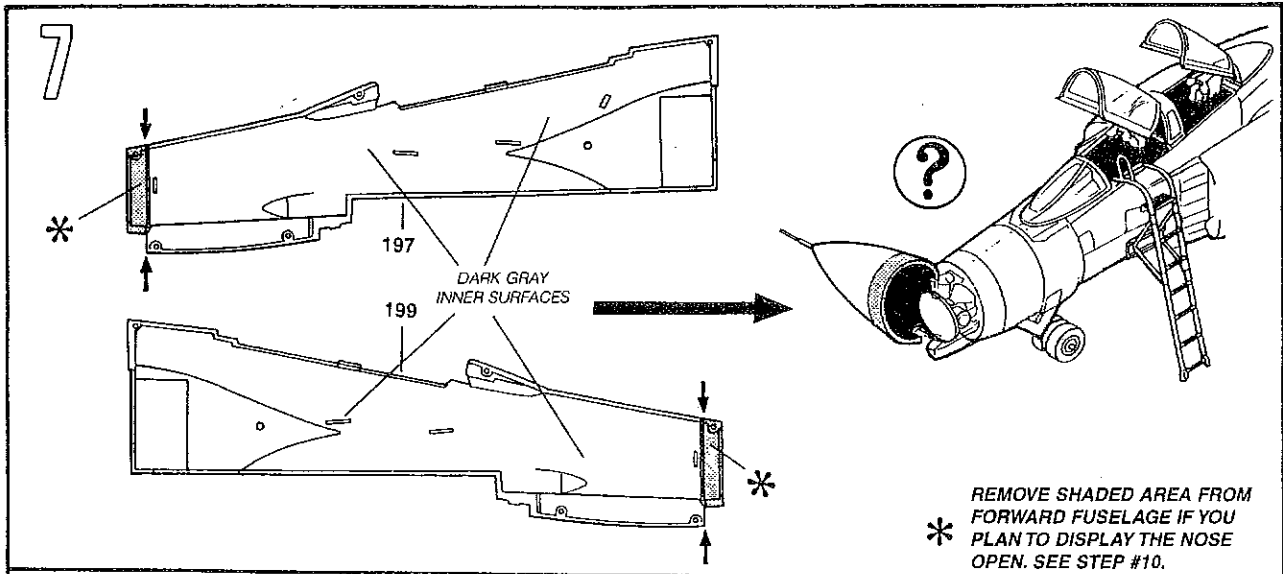

12

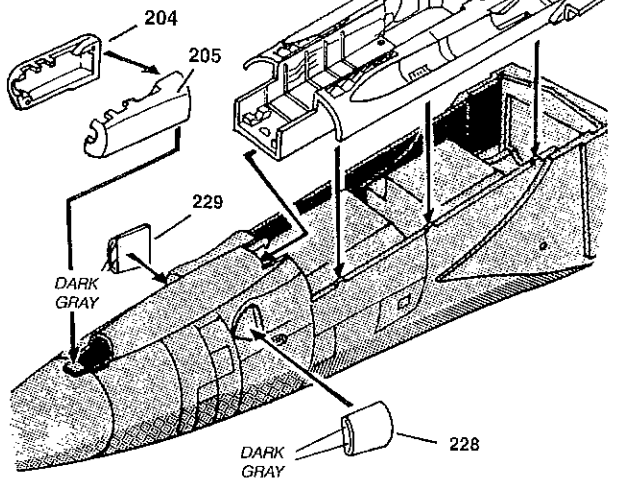

13

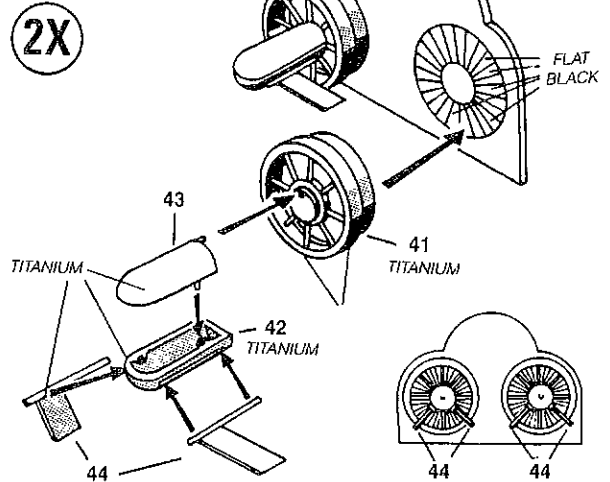

14

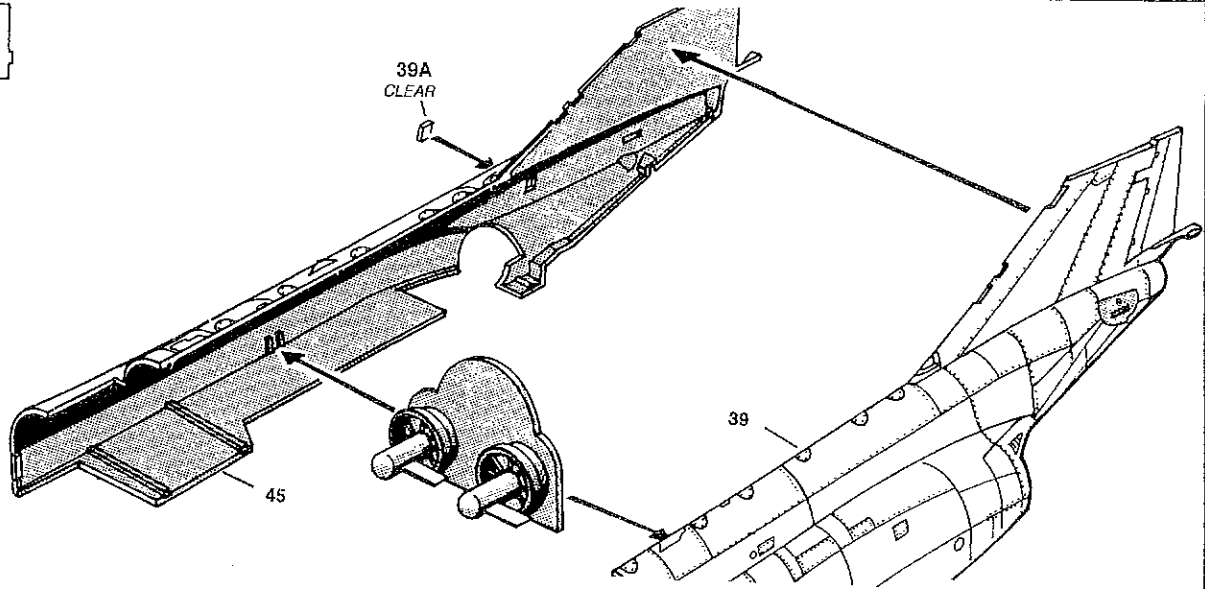

15

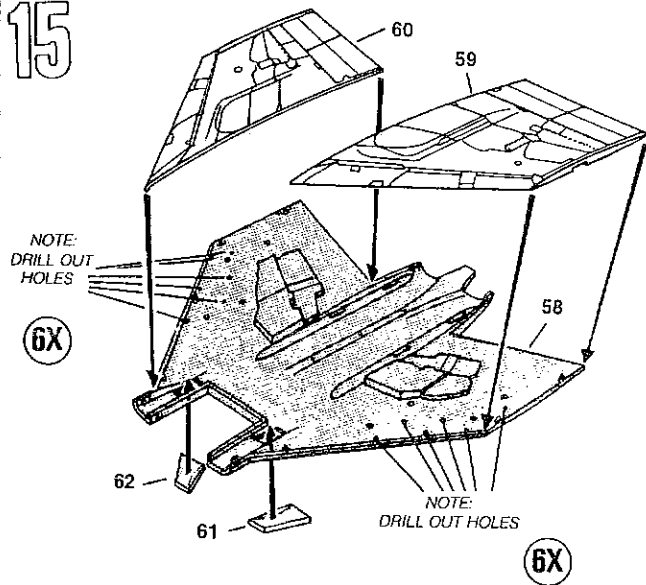

16

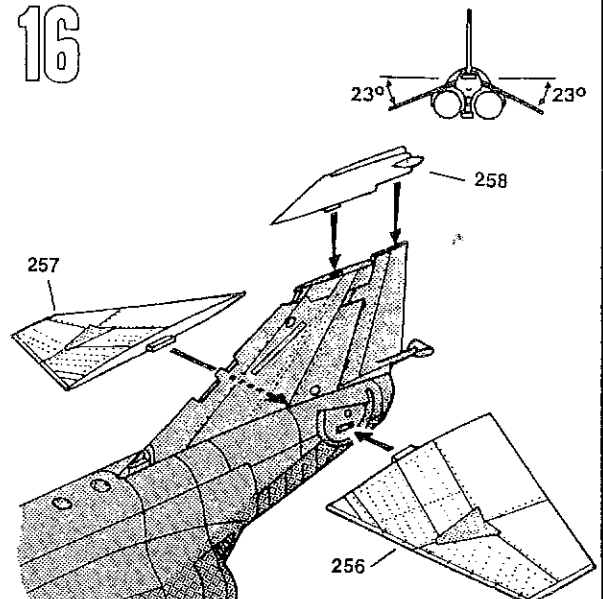

17

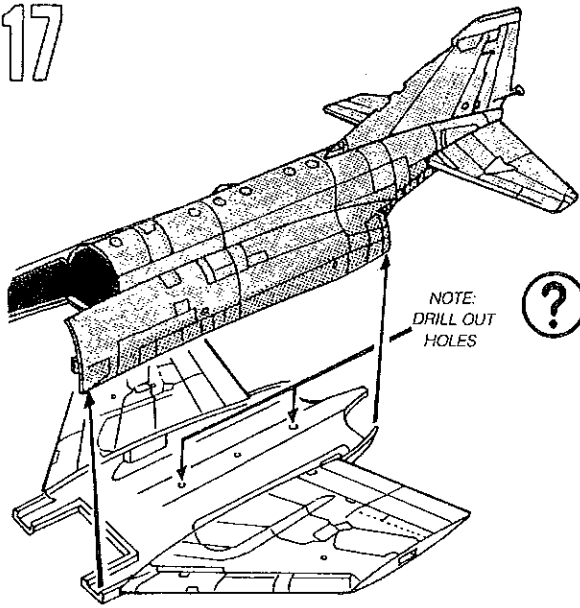

18

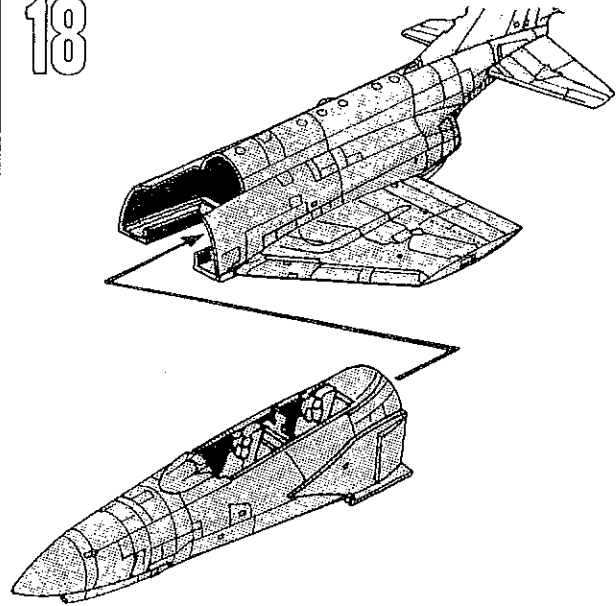

19

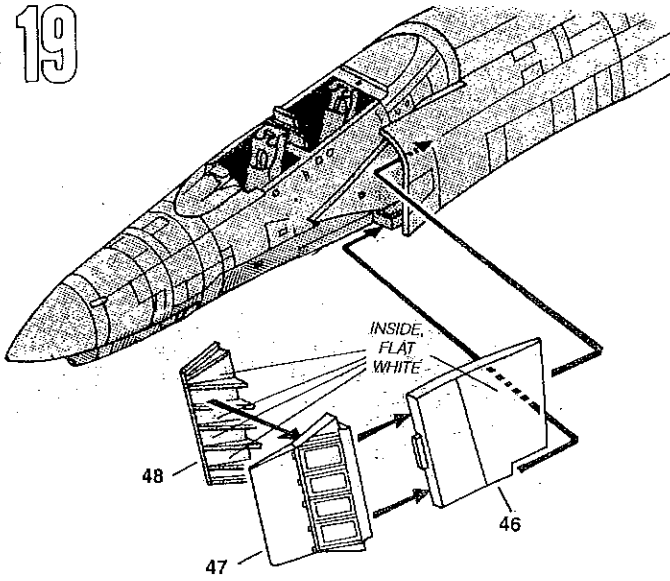

20

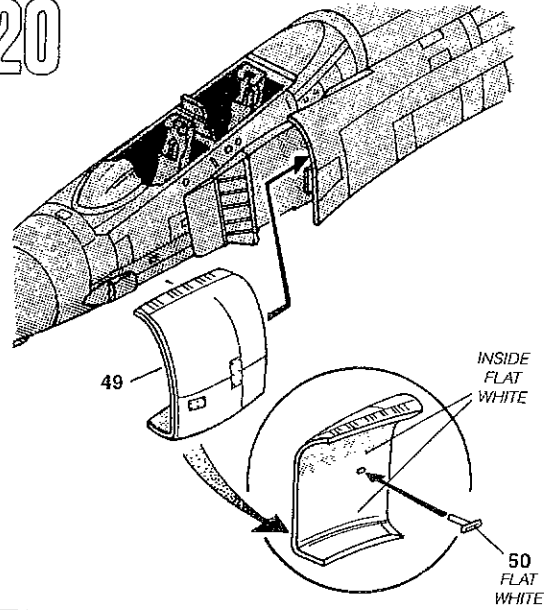

21

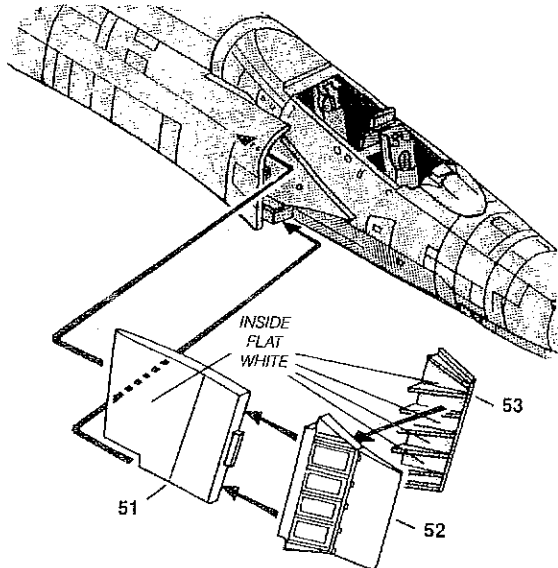

22

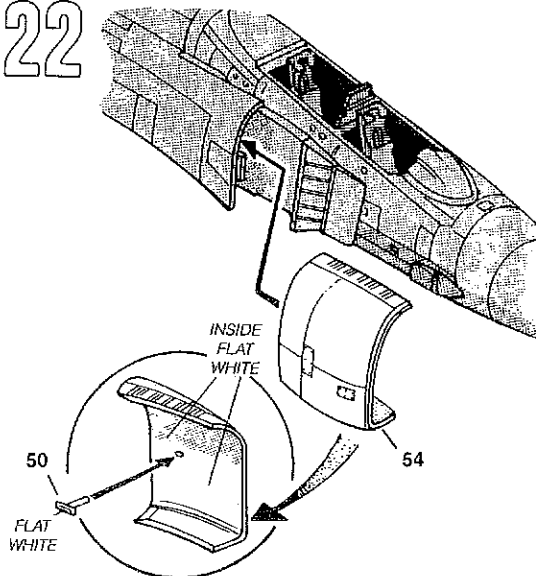

23

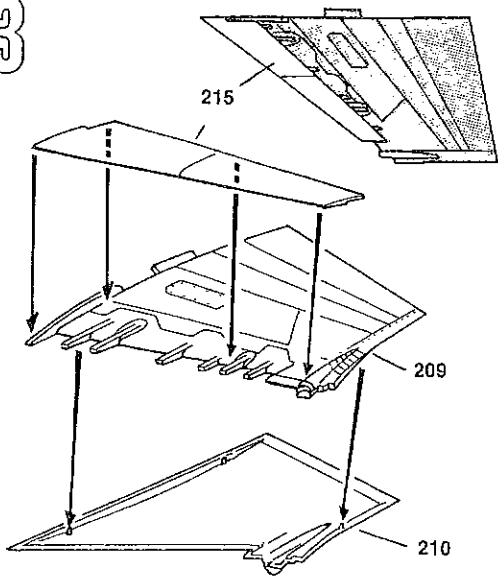

24

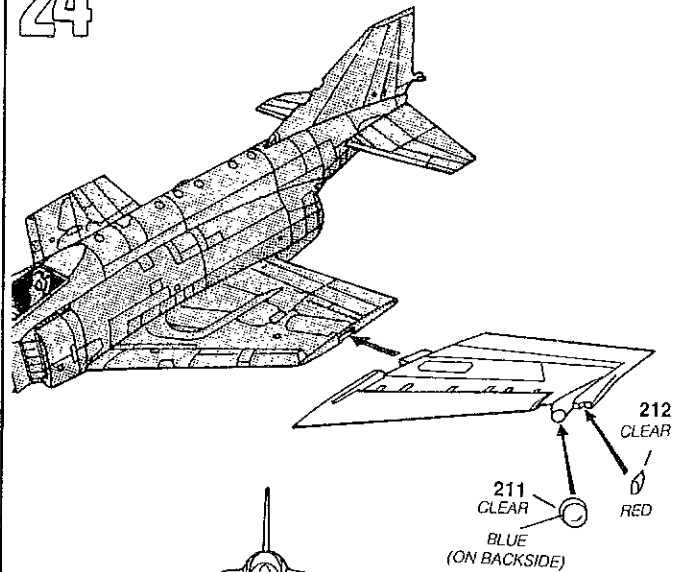

25

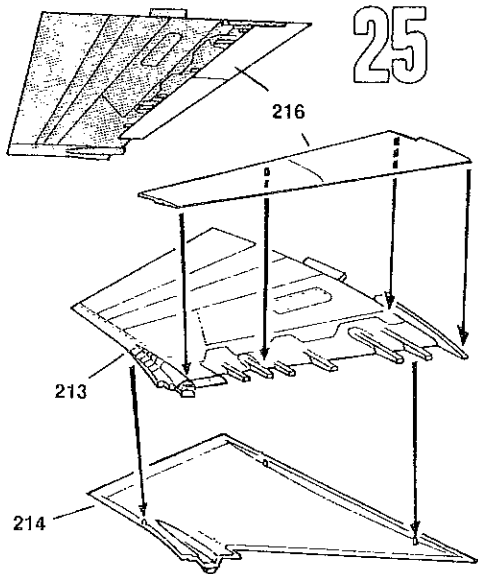

26

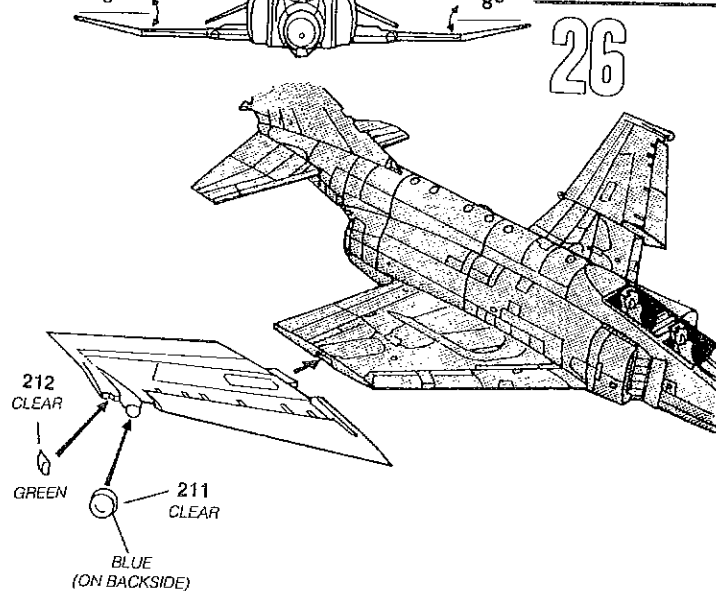

27

2X

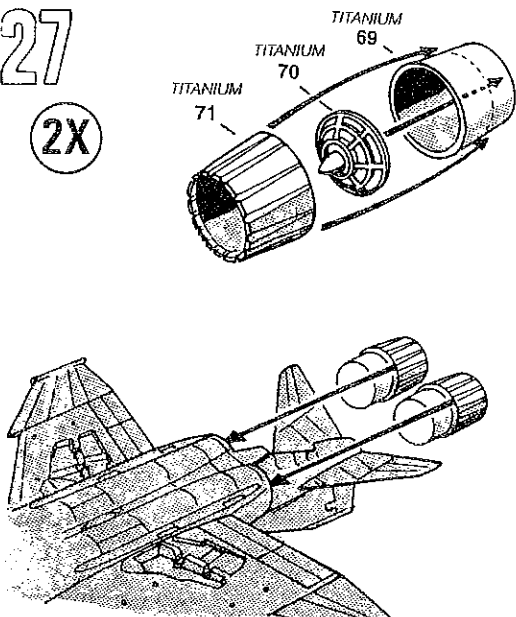

28

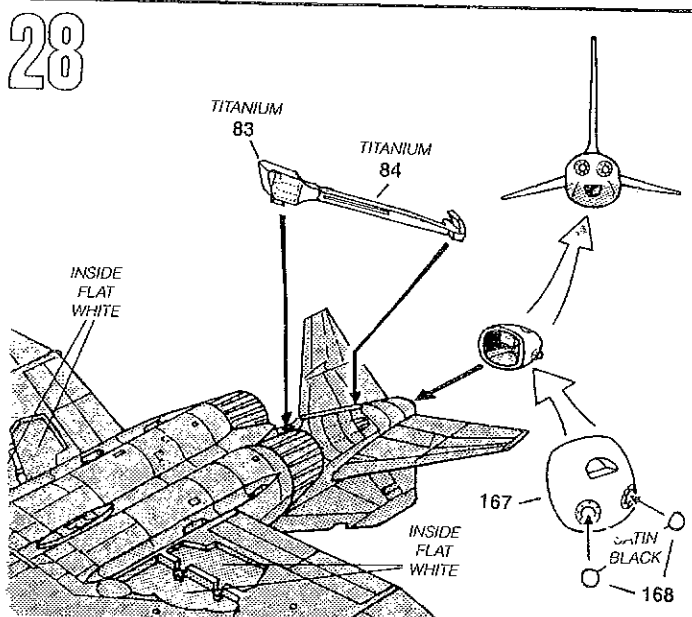

29

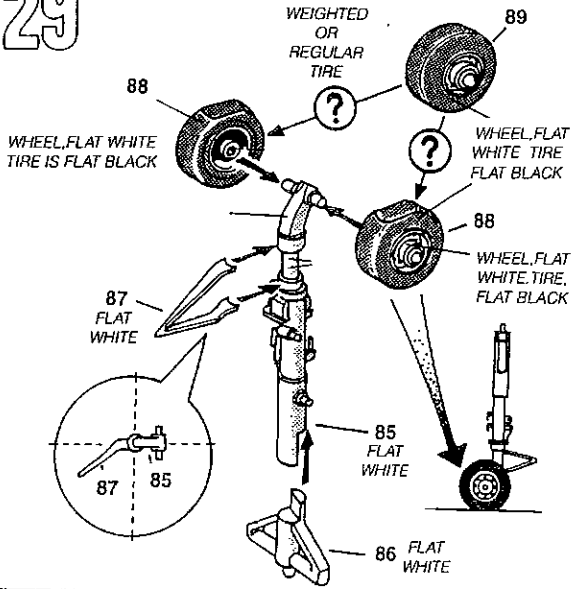

30

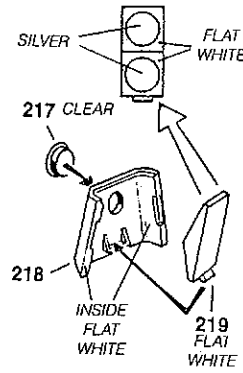

31

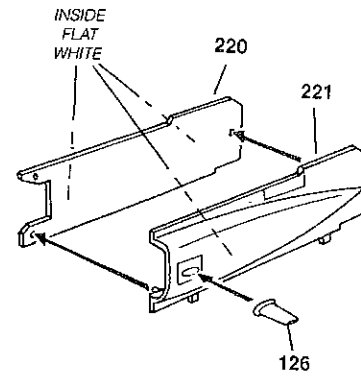

32

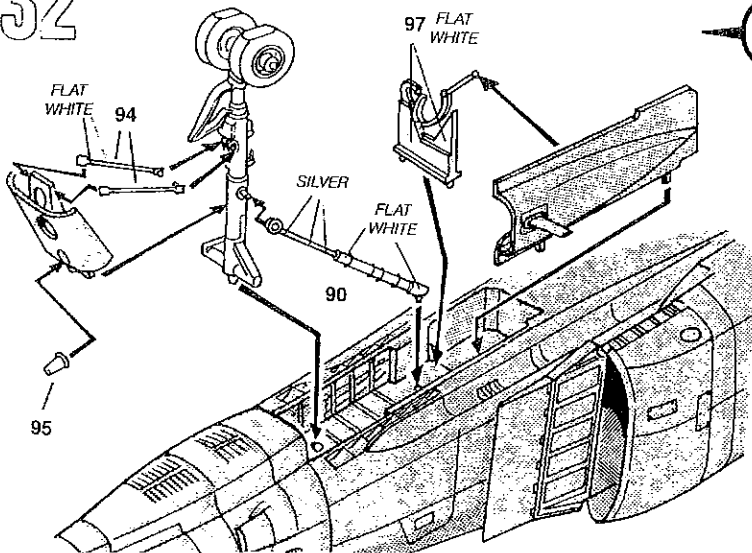

33

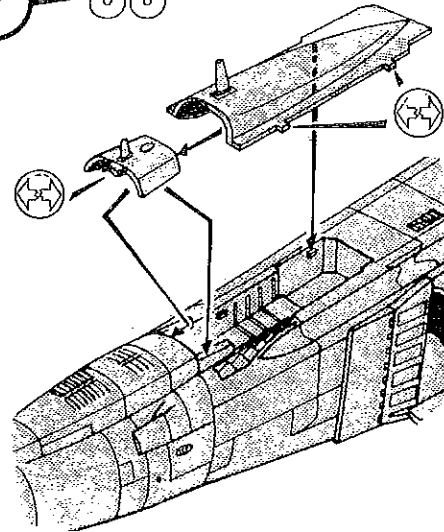

34

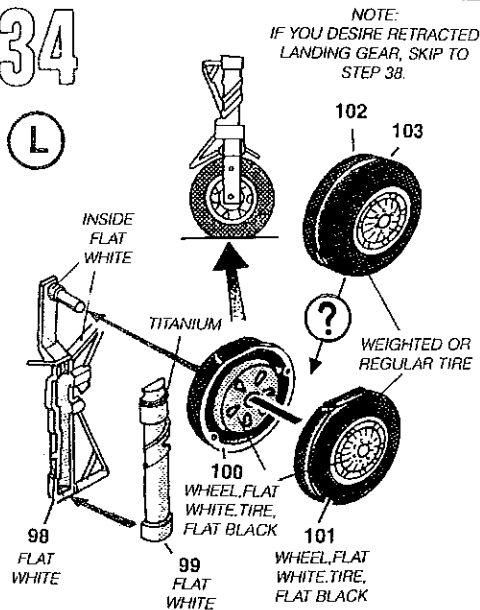

35

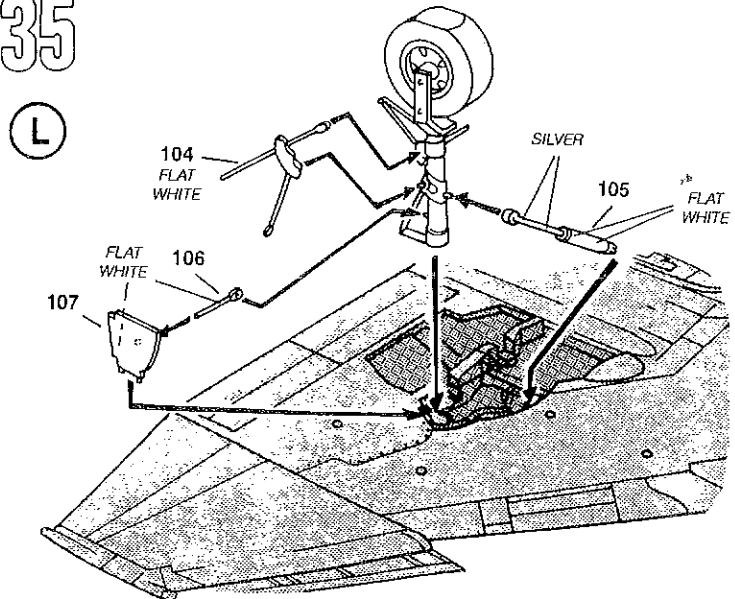

36

(L)

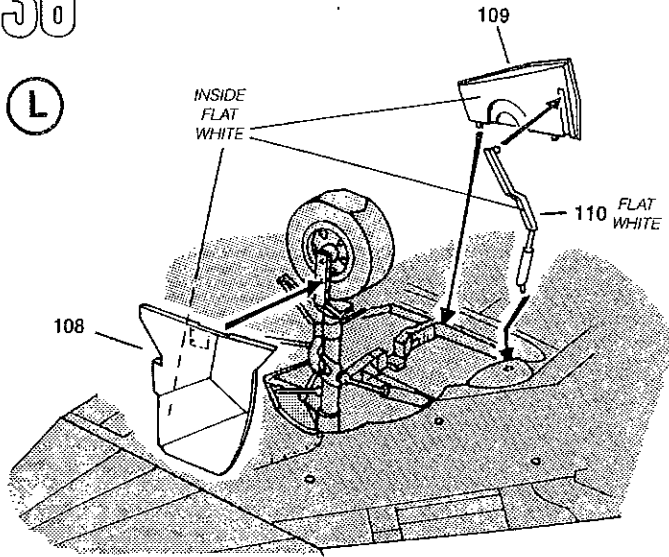

37

(L)

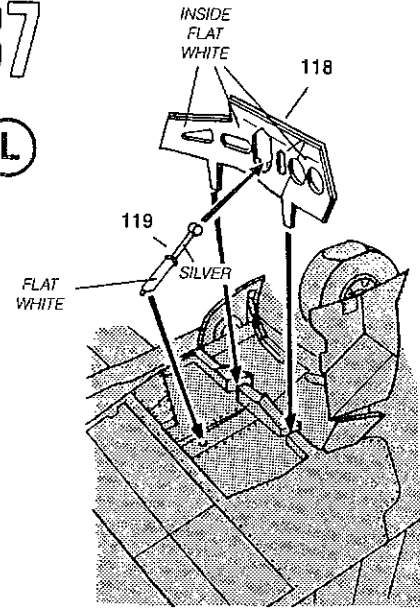

38

(L)

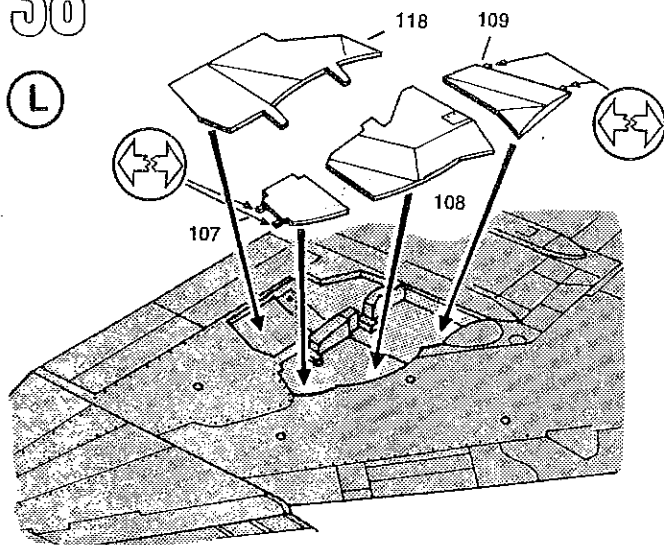

39

(R)

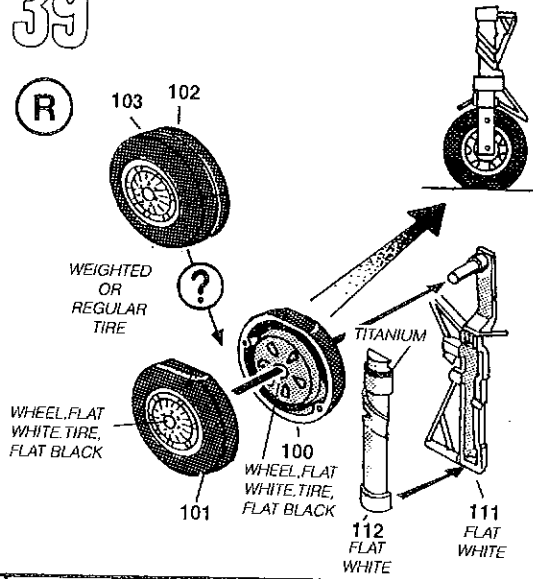

40

(R)

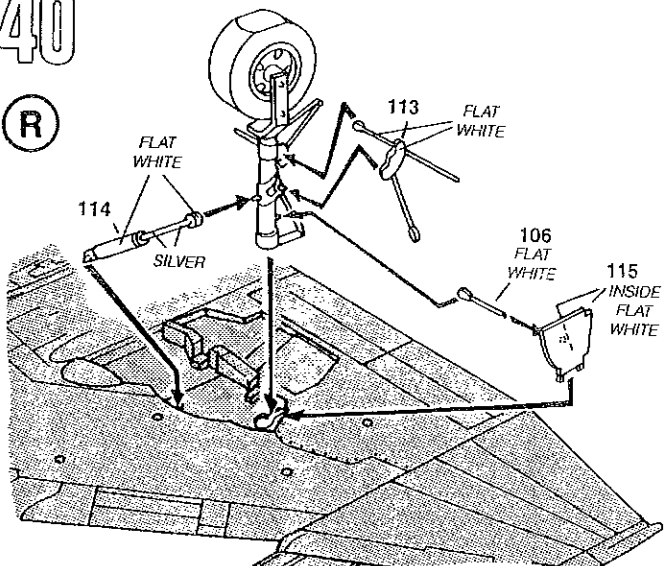

41

(R)

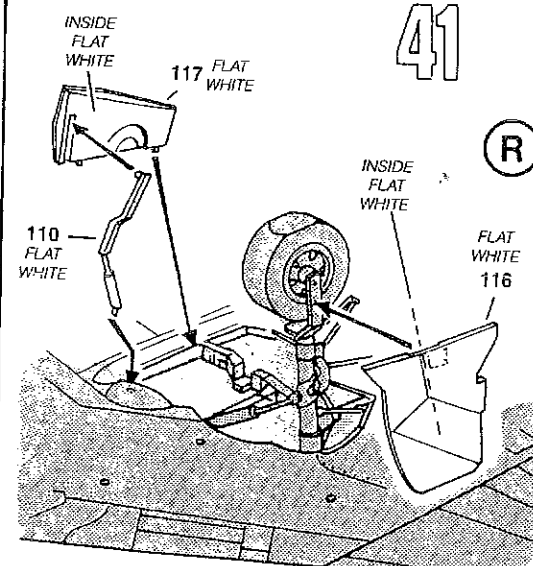

42

(R)

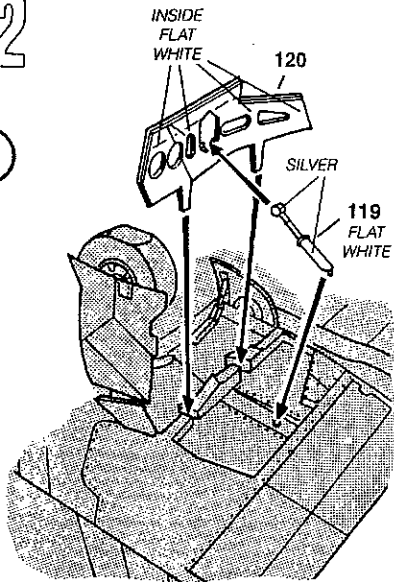

43

(R)

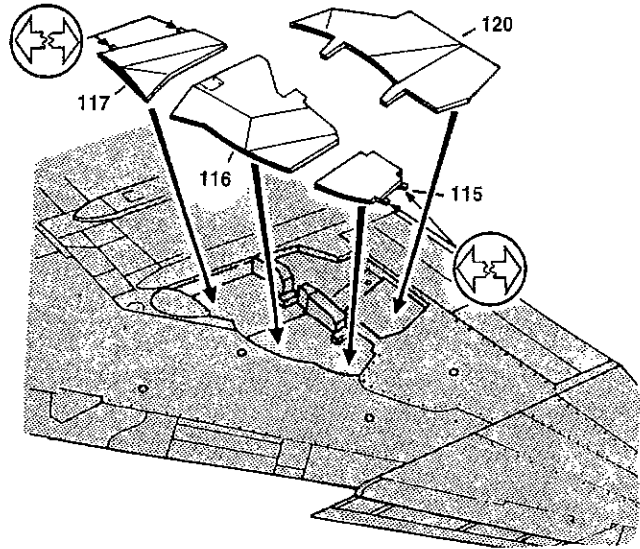

44

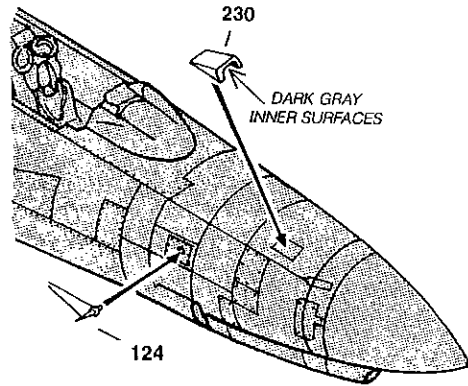

45

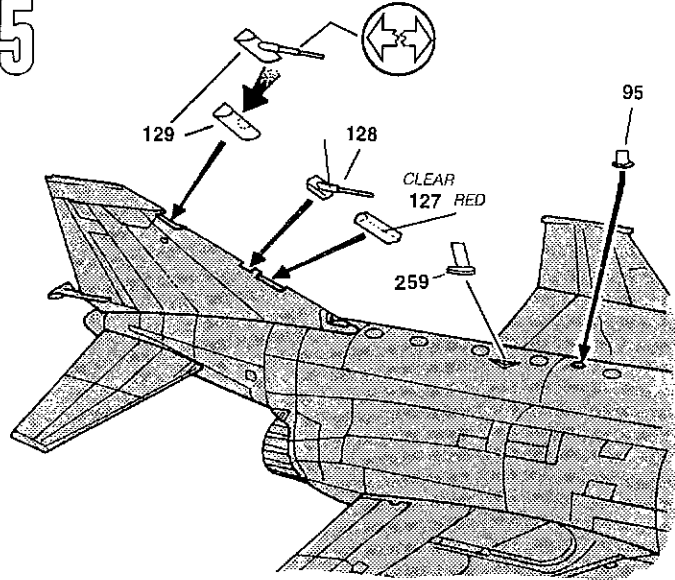

46

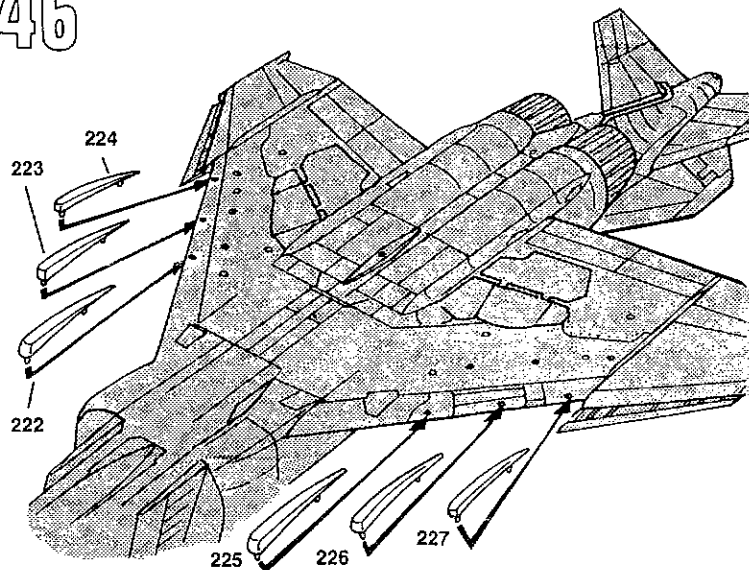

47

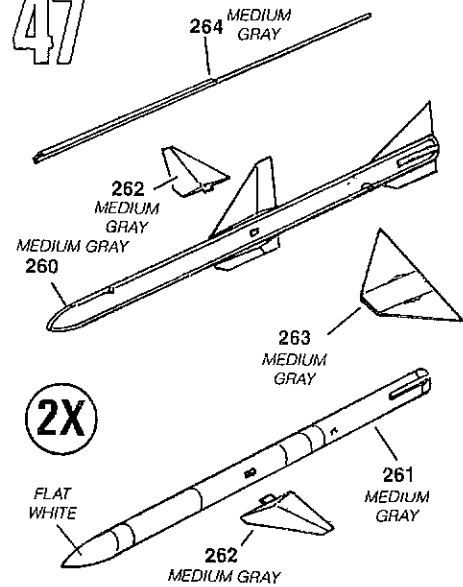

48

NOTE:
SEE DECAL PLACEMENT
GUIDE FOR PAINTING INSTRUCTIONS

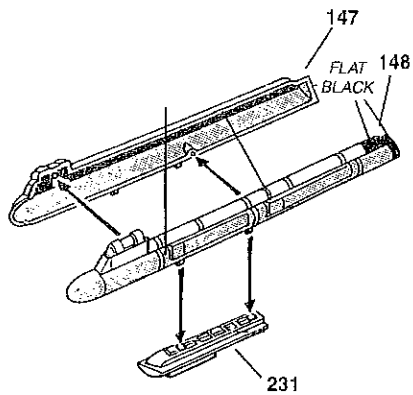

49

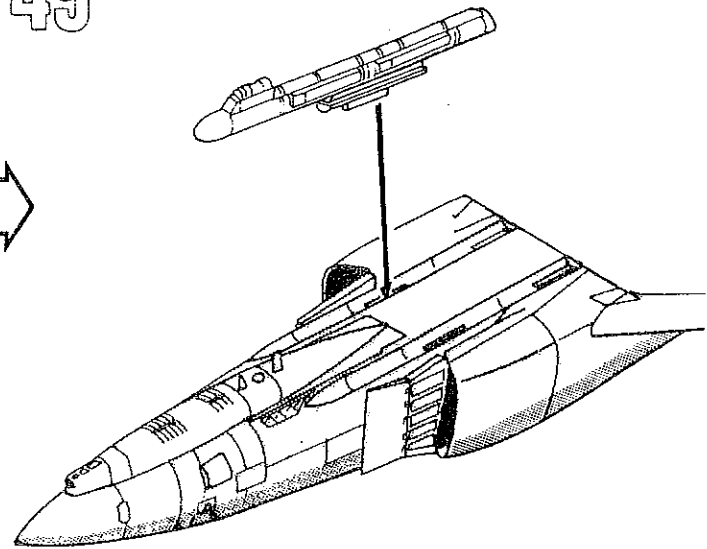

50

(R)

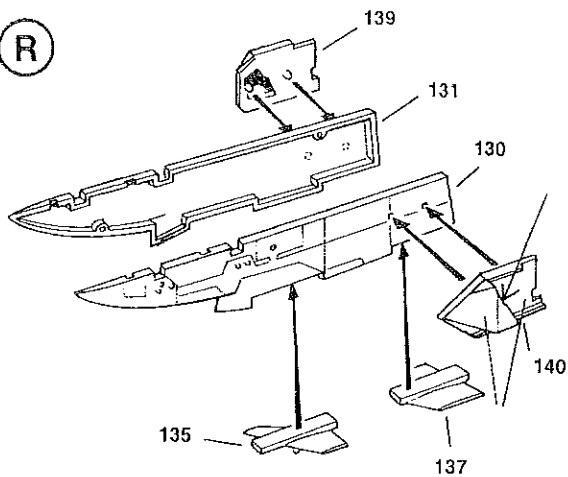

51

(L)

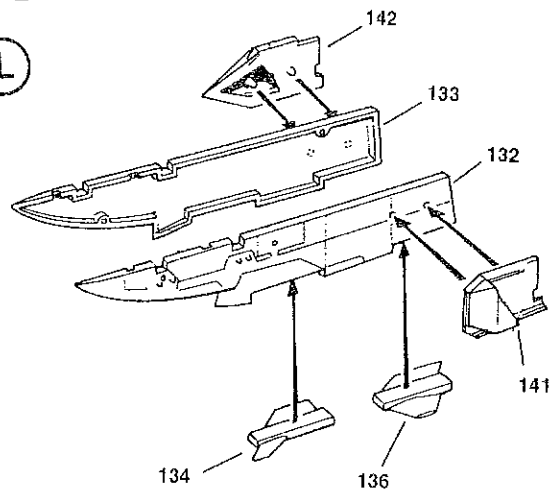

52

(2X)

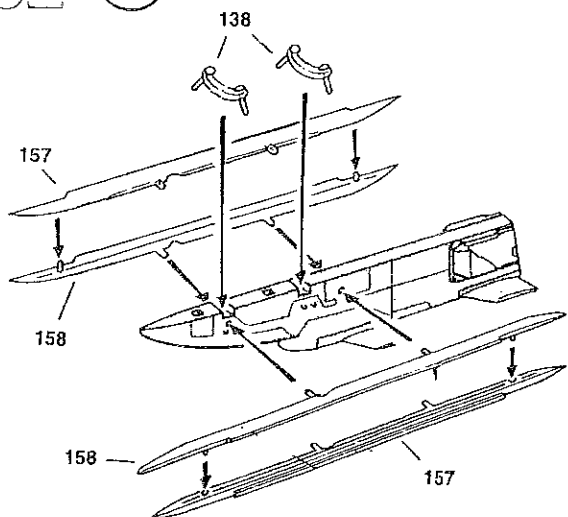

53

(4X)

NOTE:
SEE DECAL PLACEMENT
GUIDE FOR PAINTING INSTRUCTIONS

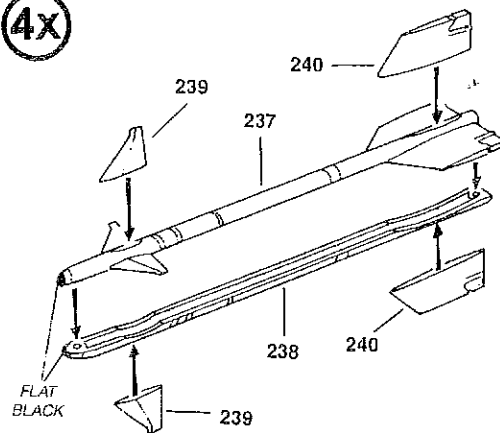

54 (2X)

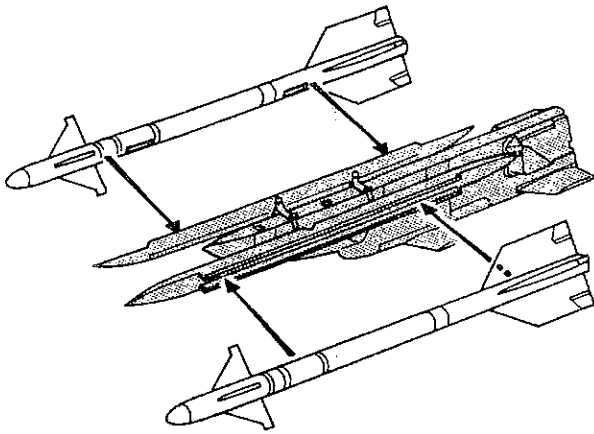

55

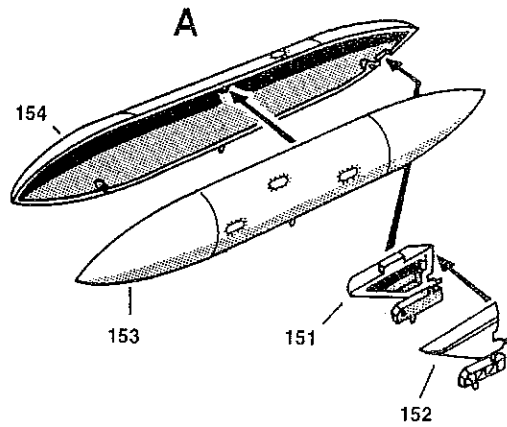

56

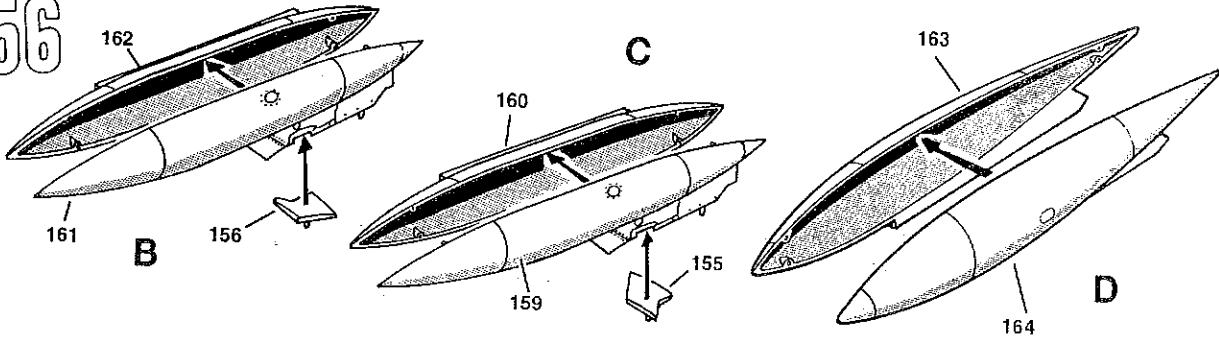

57

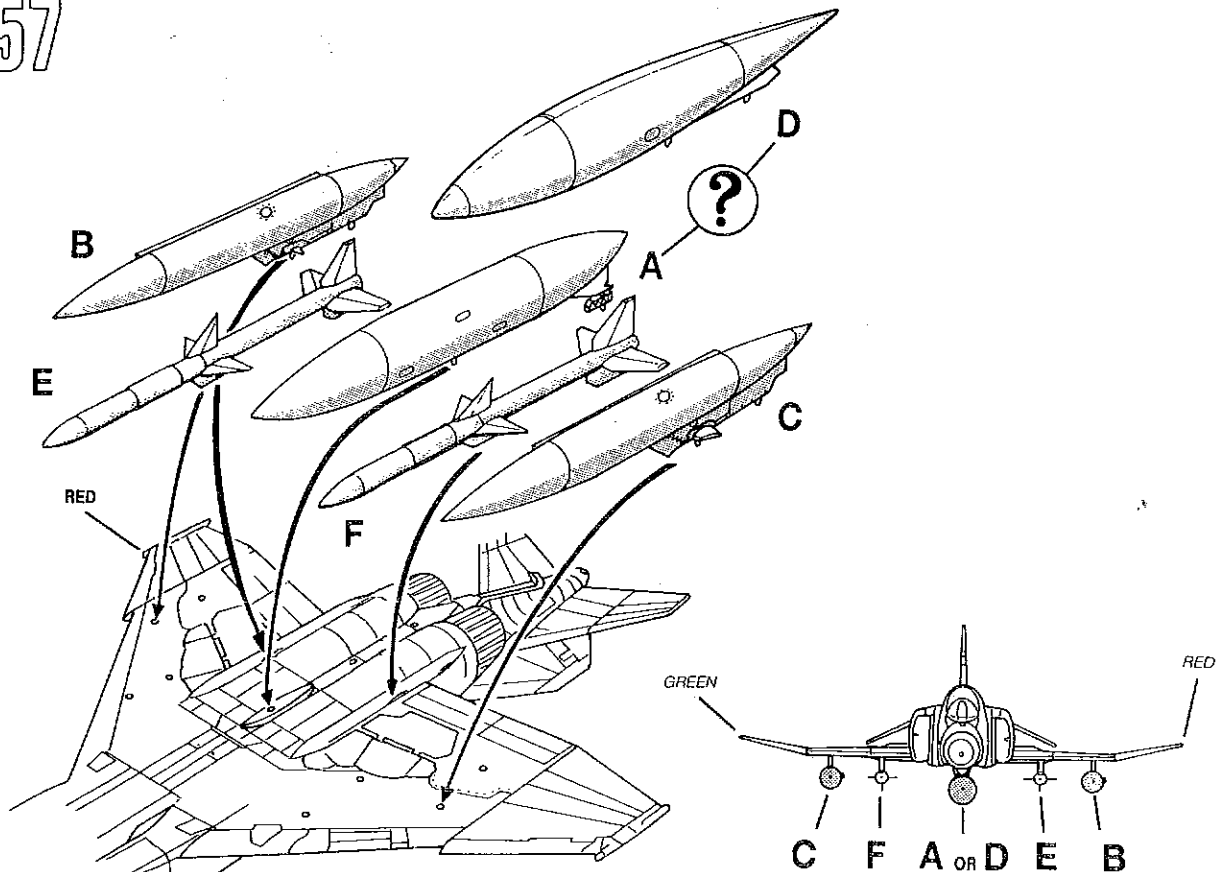

58

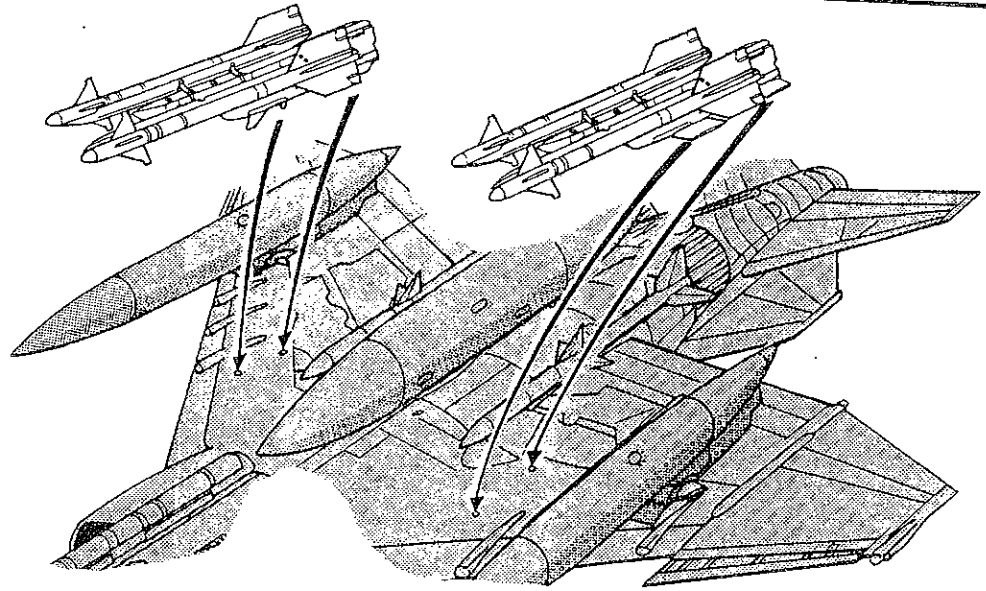

59

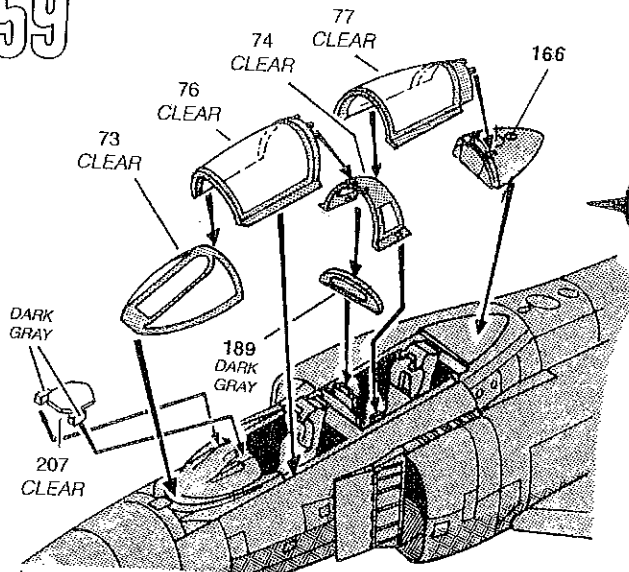

* PAINT CANOPY TRIM SURROUNDING FUSELAGE COLOR

60

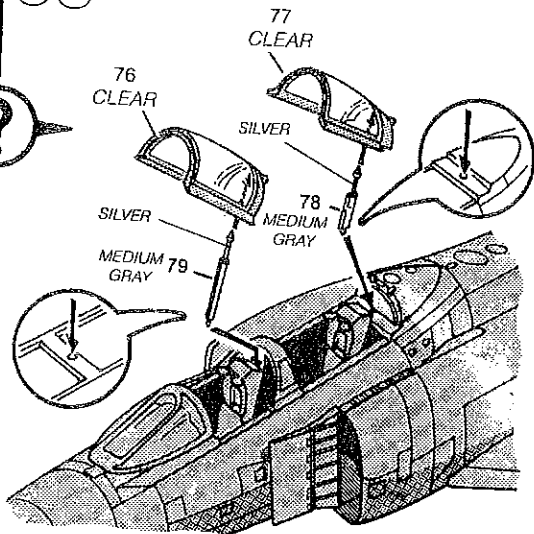

61

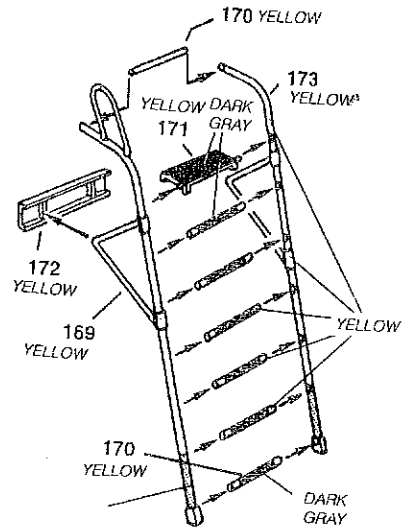
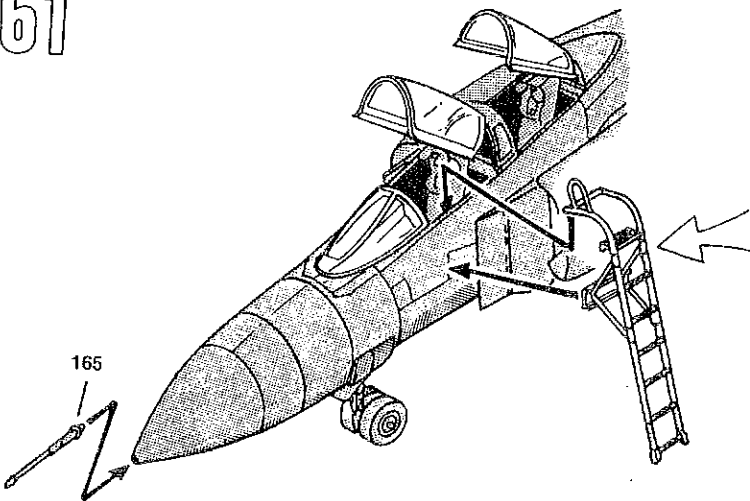

**F-4E, 131st Tactical Fighter Wing, 110th Tactical Fighter Squadron
Missouri Air National Guard. Two MIG kills in Vietnam.
30th Anniversary Phantom markings.**



- A** Medium gray FS 36270
- B** Gunship gray FS 36118
- C** Unpainted dull metal (Titanium)
- H** Insignia red FS 11136
- E** Dark gray FS 36081

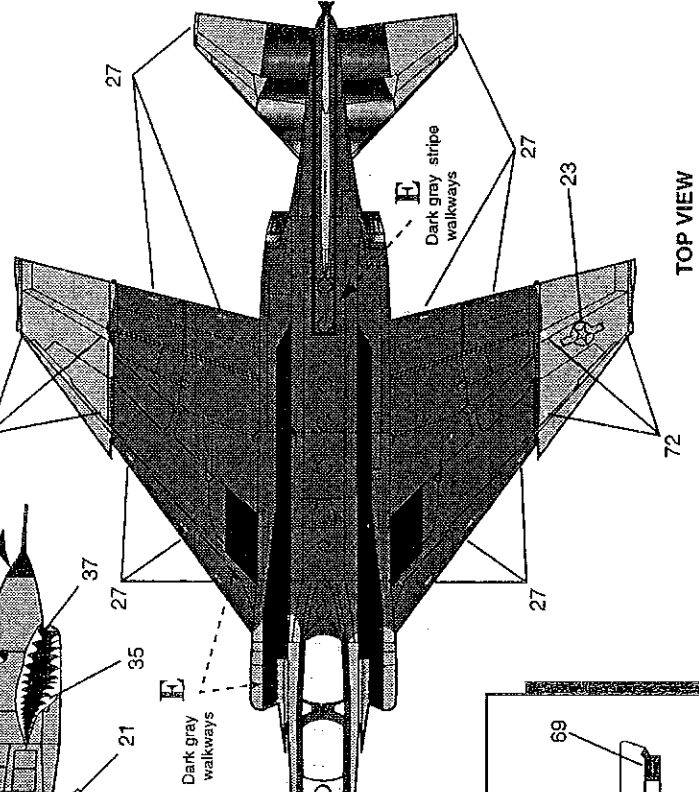
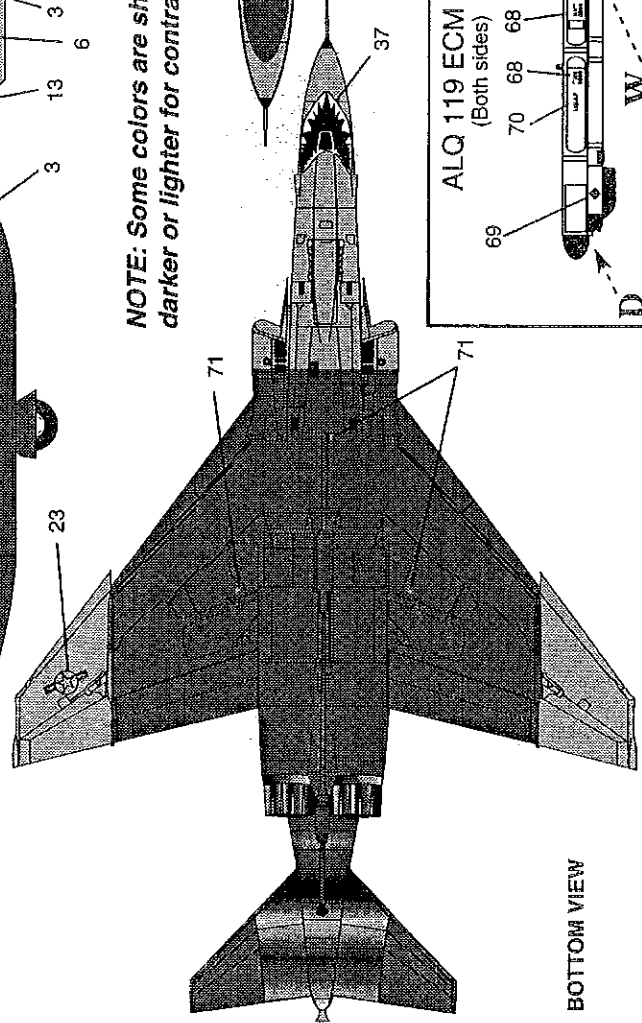
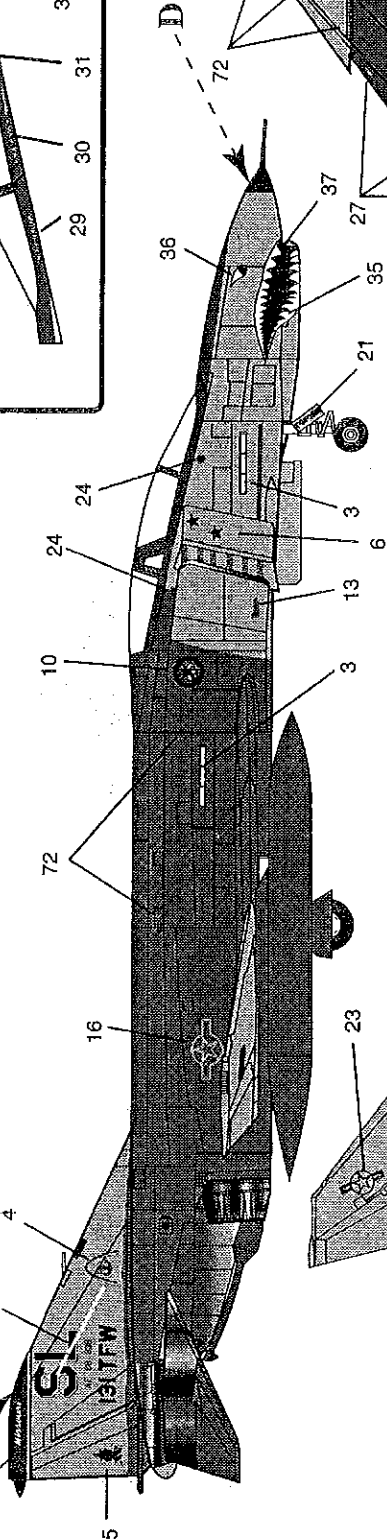
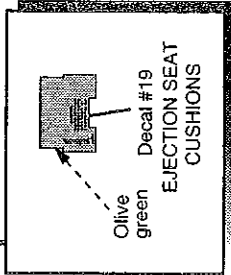
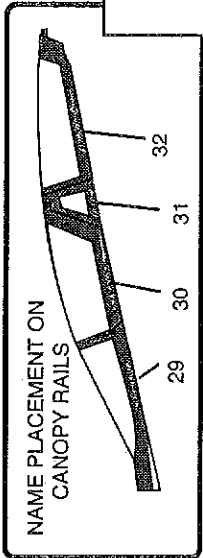
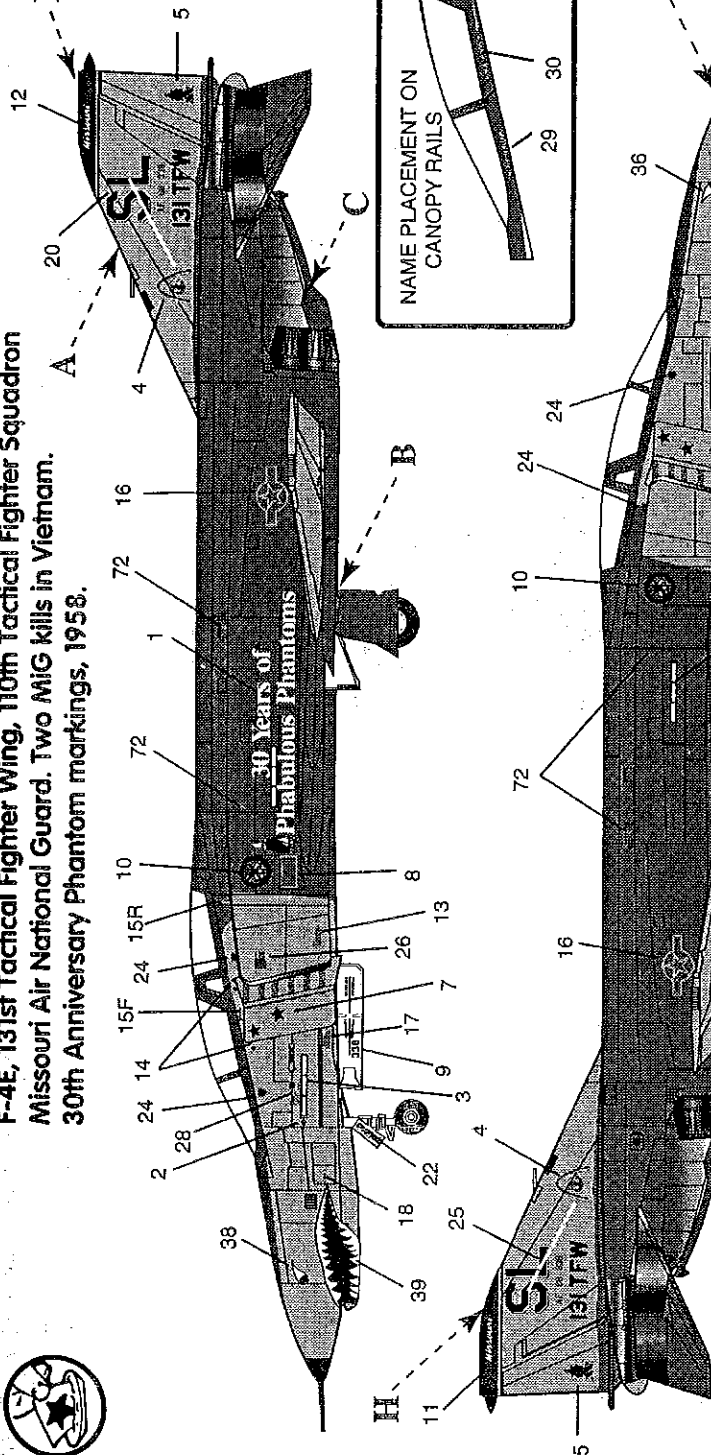

NOTE: Some colors are shown darker or lighter for contrast

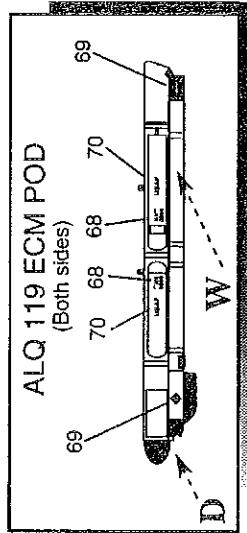

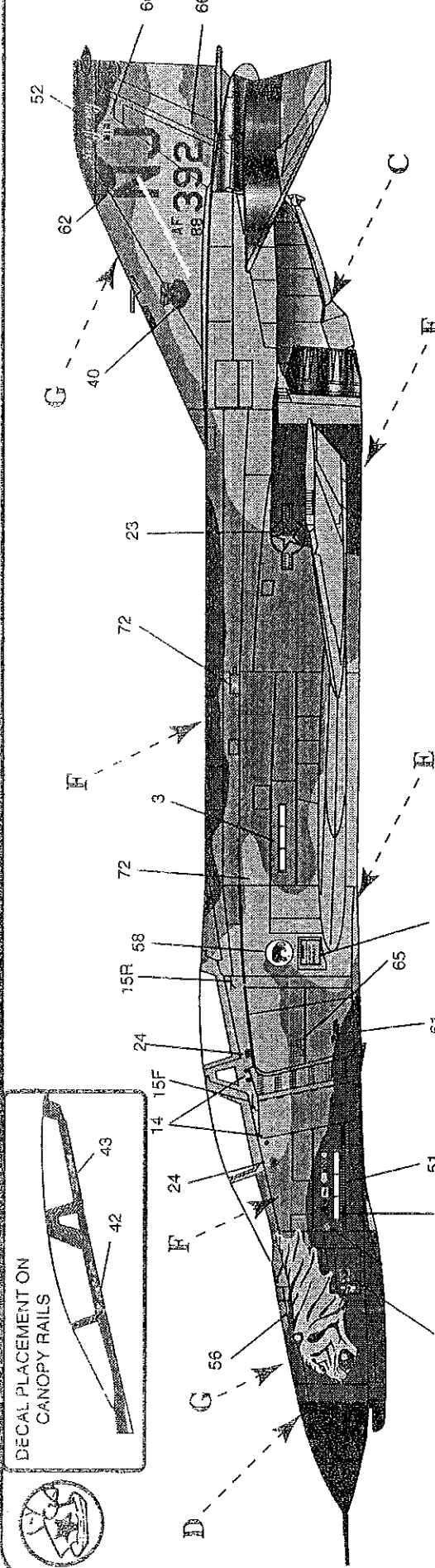

F-4E, 108th Tactical Fighter Wing, 141st Tactical Fighter Squadron
New Jersey Air National Guard.

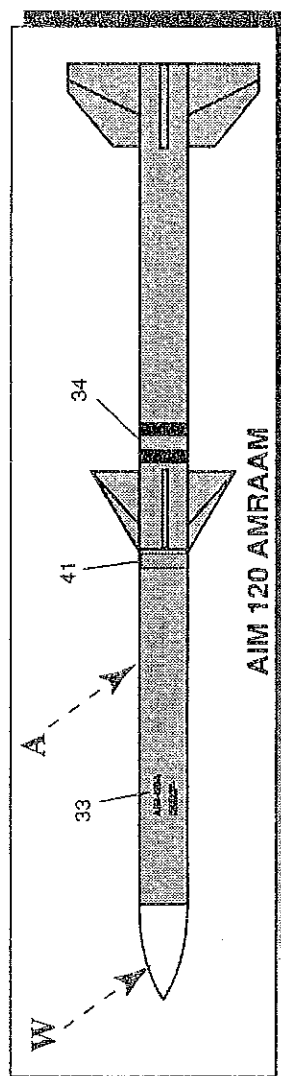
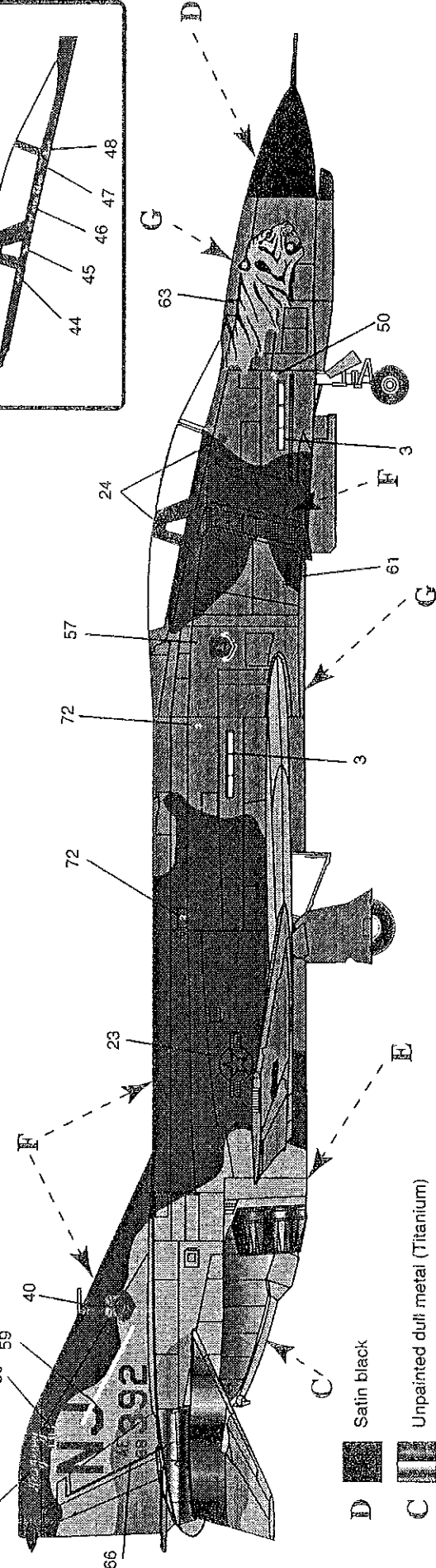

NOTE: Some colors are shown darker or lighter for contrast

- D** Satin black
- C** Unpainted dull metal (Titanium)
- E** Dark gray FS 36081
- F** Dark green FS 34079
- G** Medium green FS 34102

AIM 120 AMRAAM



DECAL APPLICATION INSTRUCTIONS

- 1.) Wash plastic parts in mild detergent solution, then rinse and let dry.
- 2.) Cut the desired decal from the sheet.
- 3.) Dip the decal in water for a few seconds.
- 4.) Place the wet decal on a paper towel.
- 5.) Wait until the decal is movable on its backing paper.
- 6.) Place the decal in position on the model with its face up, then slide the backing away.
- 7.) Press out any air bubbles with a soft damp cloth.
- 8.) The milkiness that may appear is for better decal adhesion, but will dry clear.
- 9.) Wipe away any excess adhesive.
- 10.) Do not touch the decal until it is dry.

NOTE: Some colors are shown darker or lighter for contrast

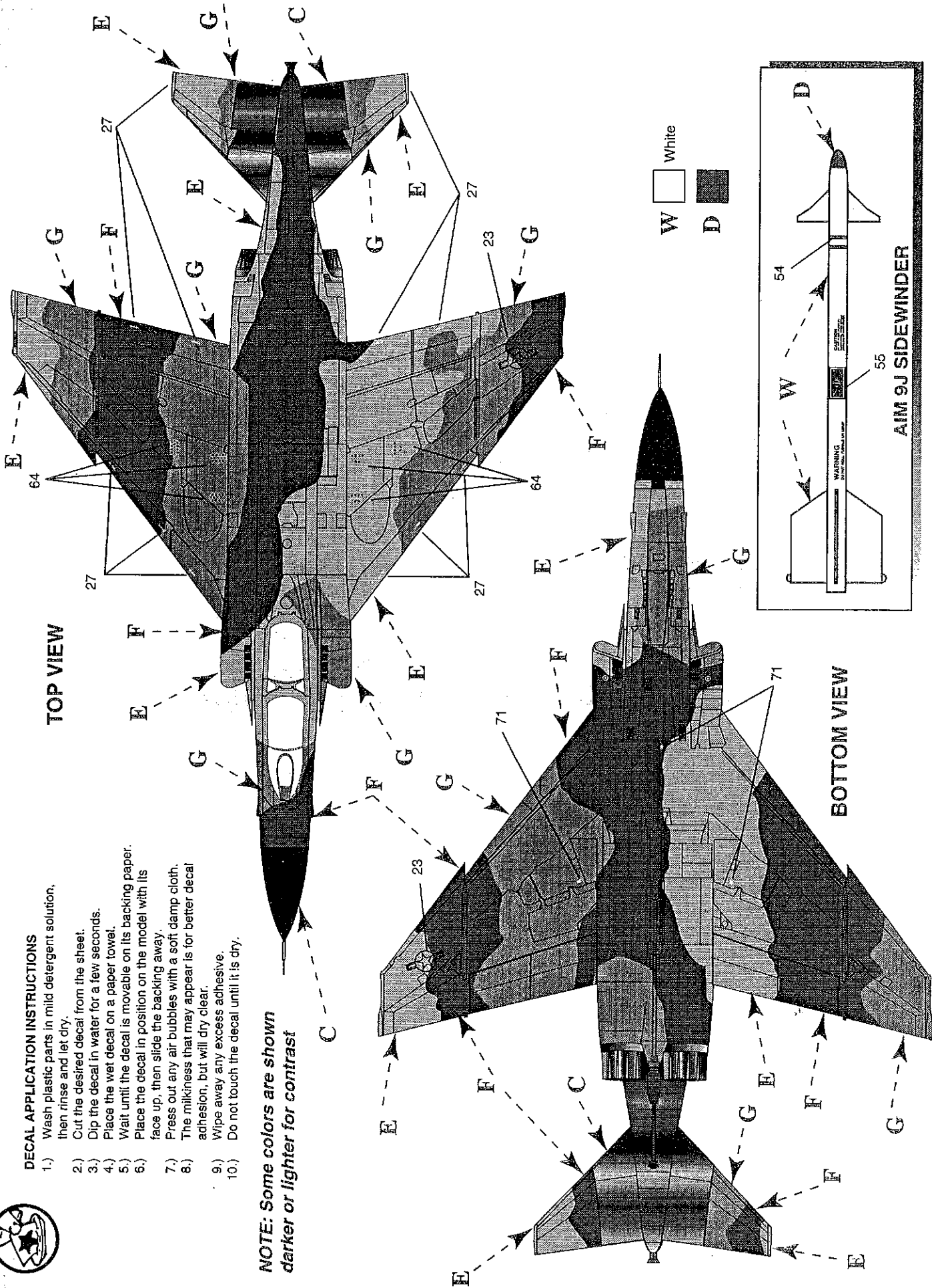

#85466800200

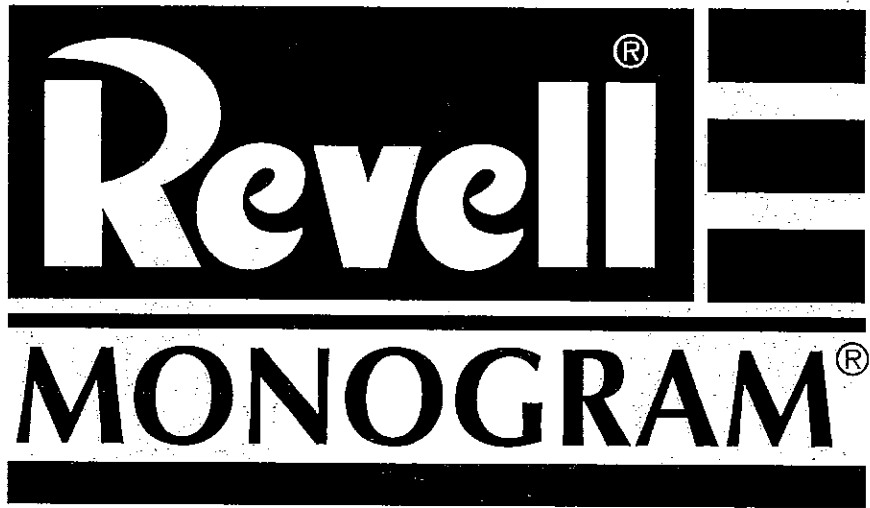

85466800200