



# 1:72 Starter Set BAe Harrier GR9A

## A55300 SCALE MODEL CONSTRUCTION KIT

**EN**

The GR9 entered service in October 2006 as an updated and improved version of the already very successful Harrier GR7. Boasting an improved avionic suite, as well as a much improved weapons capability, the GR9 represents a substantial leap forward in capability over the older GR7 Harriers. Able to carry the new Sniper targeting pods, the GR9s have proved themselves to be excellent ground attack warplanes, engaging hostile targets with great effectiveness in the skies over Afghanistan. Alongside the Sniper targeting pod, the GR9 can carry a range of offensive weapons, from the unguided CRV-7 rockets, to the very accurate laser-guided Paveway series of bombs, as well as sidewinder missiles for close quarters air defence. During their deployment to Afghanistan, the Harriers proved to be a valuable asset, able to hit targets both accurately and quickly, saving the lives of many ISAF personnel. With all of these improvements the Harrier loses none of what made it a famous and great warplane to begin with, its manoeuvrability and ability to operate from rough fields vertically still remains, enabling the Harrier

**FR**

En octobre 2006, le GR9 entra en service en tant que version actualisée et améliorée du Harrier GR7 déjà très réussi. Équipé d'une électronique aéronautique améliorée ainsi que d'une capacité d'armement perfectionnée, le GR9 représente un grand bond en avant par rapport à l'ancien Harrier GR7. Capables d'embarquer les nouvelles nacelles de désignation laser Sniper, les GR9 se sont avérés être d'excellents avions d'attaque au sol, engageant très efficacement des cibles ennemis dans l'Afghanistan. Outre la nacelle de désignation Sniper, le GR9 peut porter une gamme d'armes offensives, depuis les roquettes CRV-7 non guidées jusqu'à la série de bombes Paveway guidées par laser et très précises en passant par les missiles Sidewinder utilisés pour la défense aérienne à distance rapprochée. Pendant leur déploiement en Afghanistan, les Harrier se sont avérés être des atouts précieux, capables de frapper des cibles d'une façon précise et rapide, sauvant ainsi de nombreuses vies du personnel de la FIAS. Toutes ces améliorations assurent que le Harrier ne perd rien de ce qui l'a rendu célèbre dès son origine en tant qu'avion de combat formidable. Sa maniabilité et sa capacité d'opérer verticalement à partir de terrain

to be one of the most versatile and tactical warplanes of all time. In October 2010, it was announced that the Harrier fleet was to be retired in 2011, thus making the GR9 the final variant of the long serving Harrier to see service.

### Specification

Maximum Speed: 662 mph (1,065 km/h)

Wingspan: 9.25 m

Length: 14.36 m

Armament: AIM-9 Sidewinder, Maverick, Paveway II, Paveway III, Enhanced Paveway, General Purpose Bombs; CRV-7.

cohoteux permettent au Harrier de rester l'un des appareils de combat les plus polyvalents et tactiques de tous les temps.

En octobre 2010, il a été annoncé que la flotte Harrier serait retirée du service en 2011, ce qui veut dire que le GR9 est la dernière variante opérationnelle du Harrier.

### Spécification:

Vitesse maximale: 1.065 km/h

Envergure: 9,25 m

Longueur: 14,36 m

Armement: Sidewinder AIM-9 ; bombes Maverick, Paveway II, Paveway III, Enhanced Paveway et d'usage général ; roquettes CRV-7

## WARNING

Not suitable for children under 8 years. For use under adult supervision. Read the instructions before use, follow them and keep them for reference.

## WAARSCHUWING

Niet geschikt voor kinderen jonger dan 8 jaar. Gebruiken onder toezicht van volwassenen. Lees eerst de gebruiksaanwijzing en volg deze op. Bewaar deze om later te kunnen raadplegen.

## ATTENTION

Ne convient pas aux enfants de moins de 8 ans. À utiliser sous la surveillance d'un Adulte. Lire les instructions avant utilisation, s'y conformer et les garder comme référence.

## OSTRZEŻENIE PROEIDOPPOIΗΣΗ

Nie nadaje się dla dzieci w wieku poniżej 8 lat. Do używania pod nadzorem osoby dorosłej. Przeczytaj instrukcje przed użyciem, postępuj zgodnie z ich zaleceniami i zachowaj jako odniesienie.

Δεν είναι κατάλληλο για παιδιά κάτω των οκτώ ετών. Να χρησιμοποιείται μόνο υπό την επίβλεψη ενήλικου Διαβάστε αυτές τις οδηγίες πριν από τη χρήση, ακολουθήστε τις και κρατήστε τις για μελλοντική χρήση.

## ACHTUNG

Nicht geeignet für Kinder unter ... Jahren 8. Benutzung unter Aufsicht von Erwachsenen. Lies die Anweisungen vor Gebrauch, befolge sie und halte sie nachschlagebereit.

## ADVERSEL

Ikke egnet for barn under 8 år. Skal brukes under tilsyn av en voksen. Les bruksanvisningene før bruk, følg dem og ta vare på dem.

## VAROITUS

Ei alle 8 -vuotiaalle lapsille. Lelua saa käyttää vain aikuisen valvonnassa. Lue käyttöohjeet ennen käyttöä ja noudata niitä. Säilytä ohjeet vastaisuuden varalle.

## ADVERTENCIA

No conviene para niños menores de 8 años. Utilícelo bajo la vigilancia de un adulto. Leer las instrucciones antes de la utilización, seguirías y conservarlas como referencia.

## AVVERTENZA

Non adatto a bambini di età inferiore a 8 anni. Da usare sotto la sorveglianza di un adulto. Leggere le istruzioni prima dell'uso, attenersi ad esse e conservarle per riferimento futuro.

## ADVARSEL

Ikke egnet for barn under 8 år. Skal anvendes under opsyn af en voksen. Læs brugsanvisningen før brug, følg den og gem den til senere brug.

## VARNING

Inte lämplig för barn under 8 år. Skå användas under tillsyn av vuxen. Läs anvisningarna före användningen, följ dem och spara dem för framtida bruk.

## ATENÇÃO

Contra-indicado para crianças com menos de 8 anos. A utilizar sob a vigilância de adultos. Ler as instruções antes de utilizar e conservá-las como informação.

## UPOZORNĚNÍ

Nevhodné pro děti do 8 let. Používat pouze pod dohledem dospělých osob. Před použitím si přečtěte návod, dodržujte jej a uschovejte jej pro pozdější potřebu.

### FOR BEST RESULTS:

Surfaces to be painted should be clean — before parts are removed from the sprue, wash in warm, soapy water, rinse and dry thoroughly. Stir paints thoroughly before use.

### PLEASE NOTE:

Additional paints may sometimes be required to complete models to a higher specification. Some parts in the kit may not be required to build the model specified.

**HORNBY  
HOBBIES**



Manufactured by: Hornby Hobbies Ltd Westwood, Margate, Kent, CT9 4JX, UK +44(0)1843 233525 customerservices.uk@hornby.com

EU Authorised Representative: Hornby Italia SRL Viale dei Caduti, 52/A6, Castel Mella (BS), Italy, 25030 +39 0687501292 customerservices.it@hornby.com



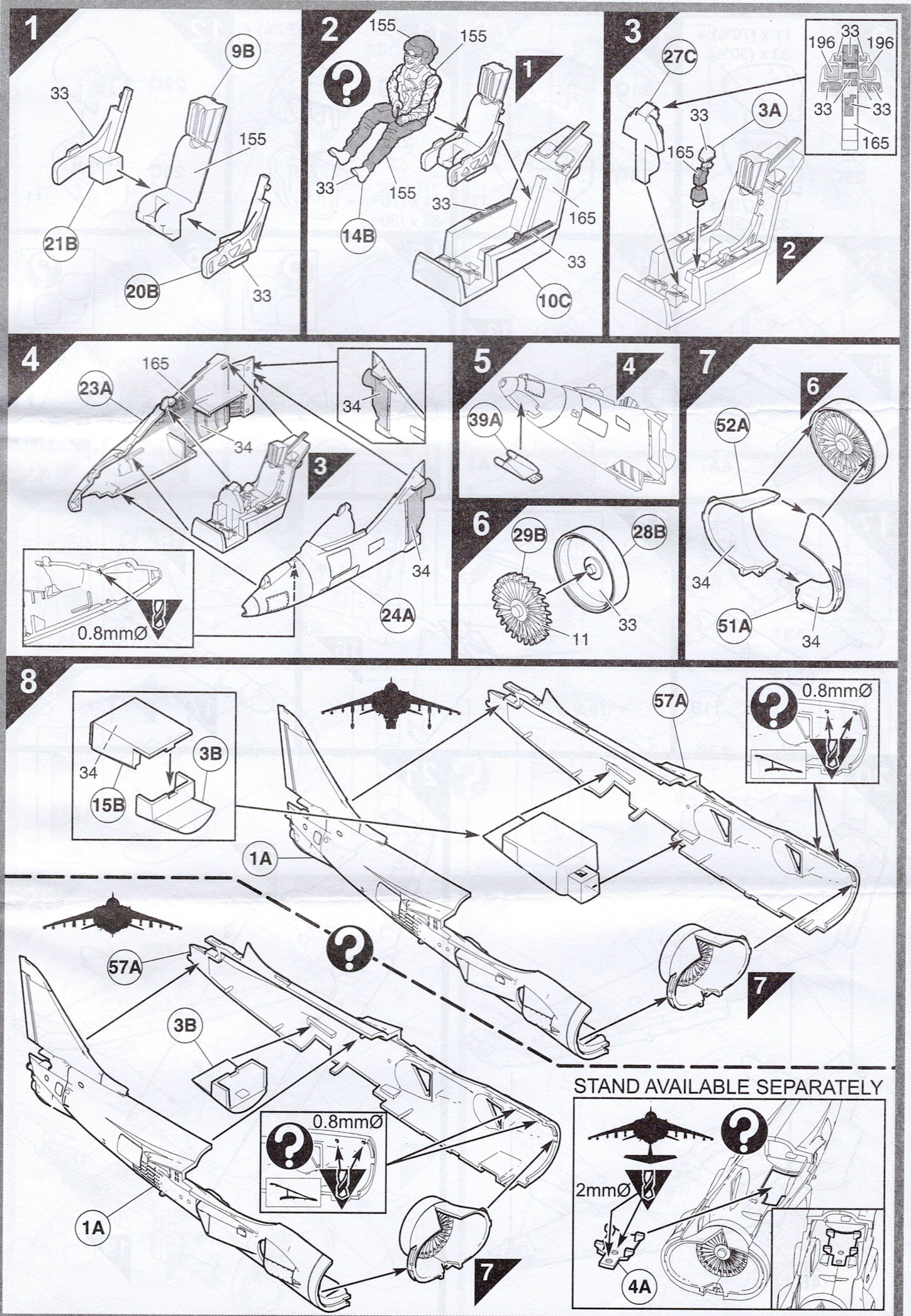



9

11 x (70%) +  
33 x (30%)

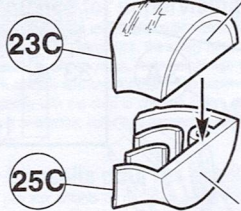

11 x (70%) +  
33 x (30%)

10

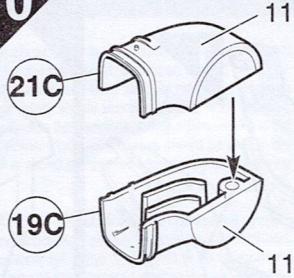

11

11 x (70%) +  
33 x (30%)

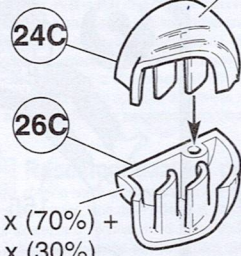

11 x (70%) +  
33 x (30%)

12

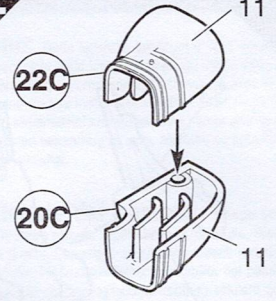

13

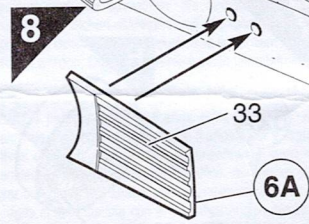

14

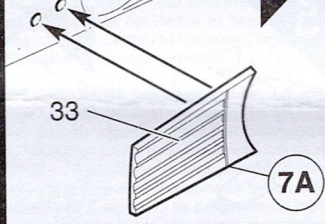

15

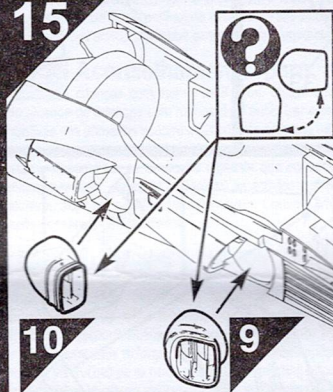

16

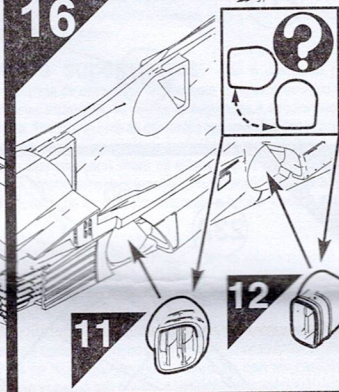

17

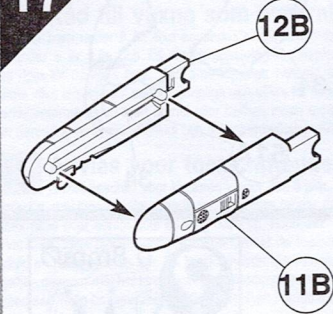

18

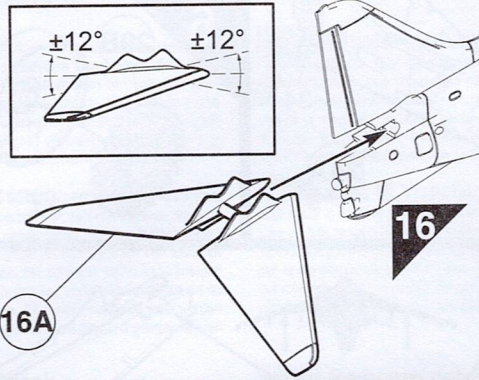

19

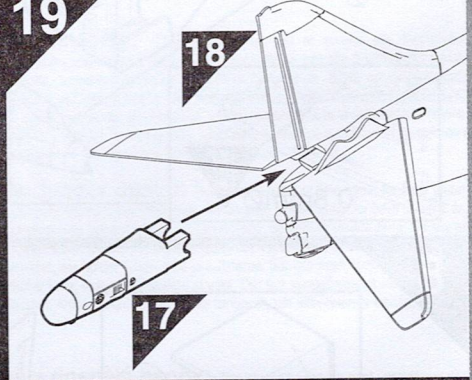

20

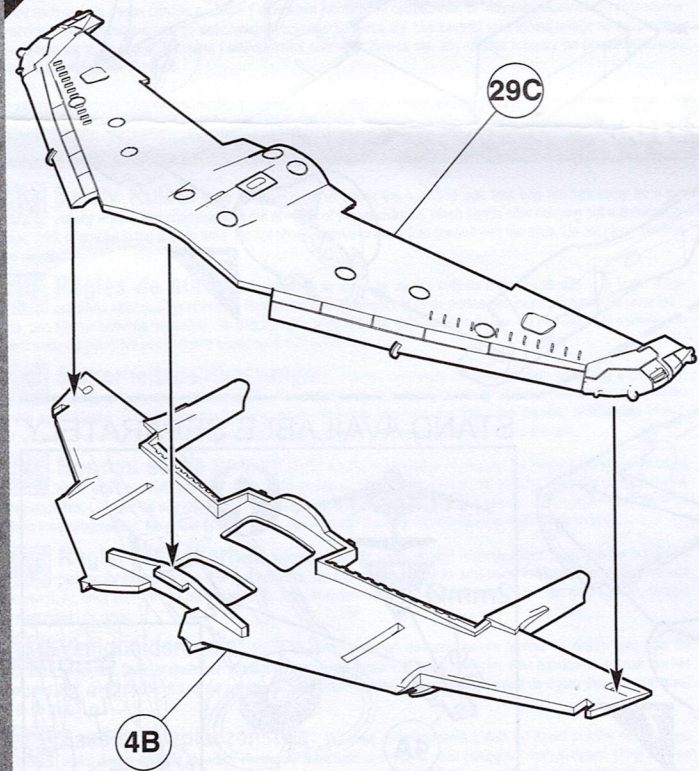

21

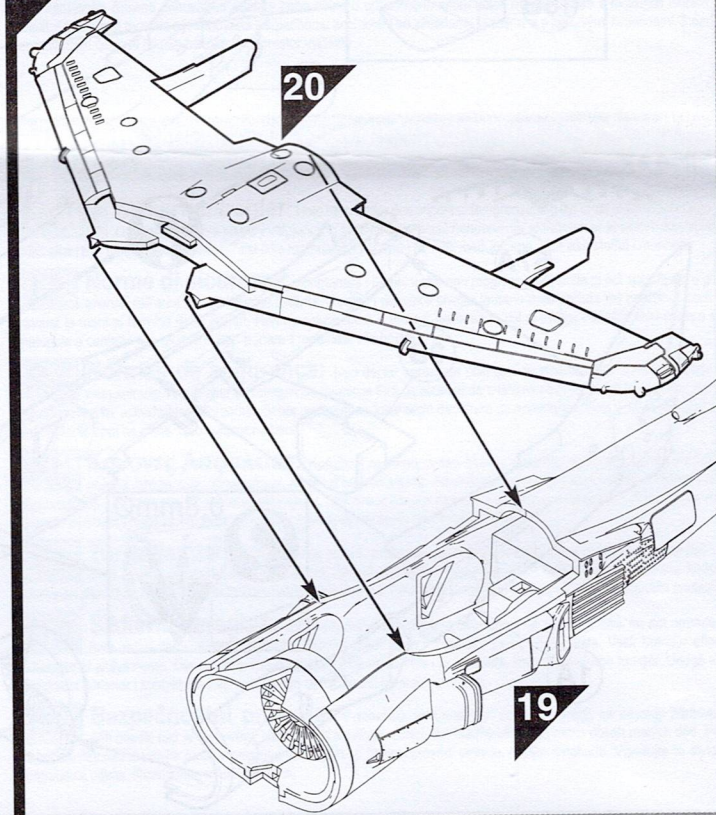



22

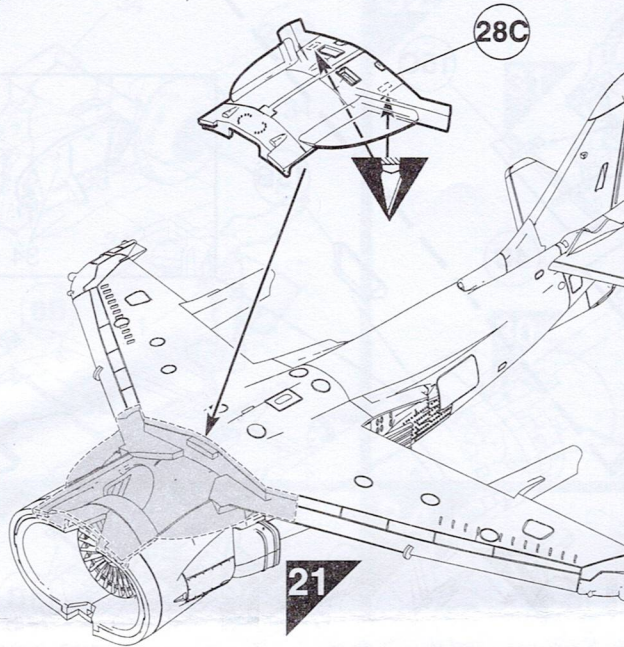

23

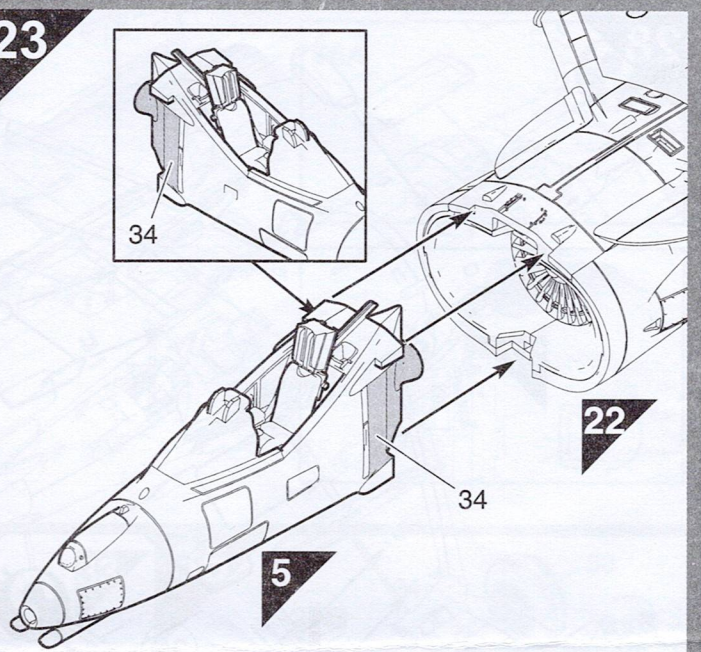

24

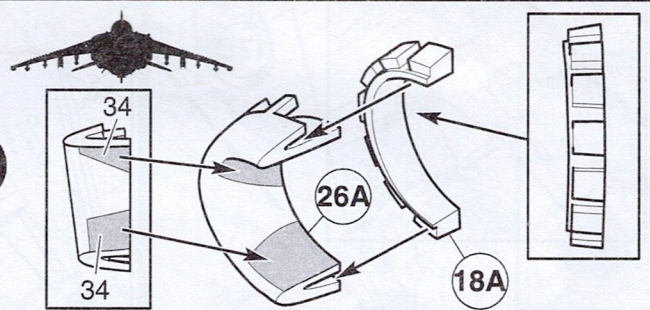
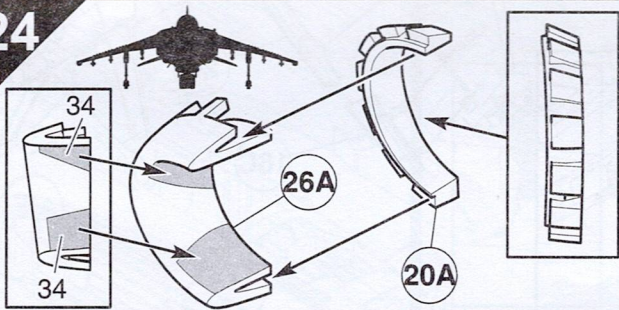

25

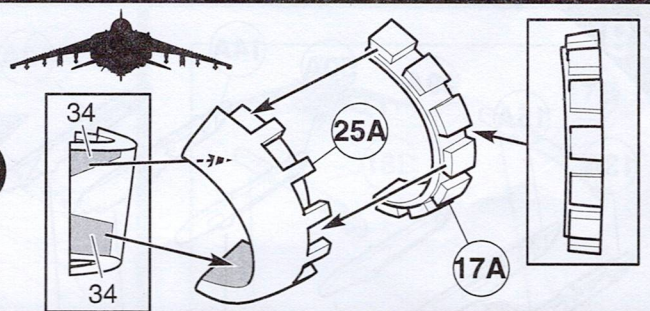
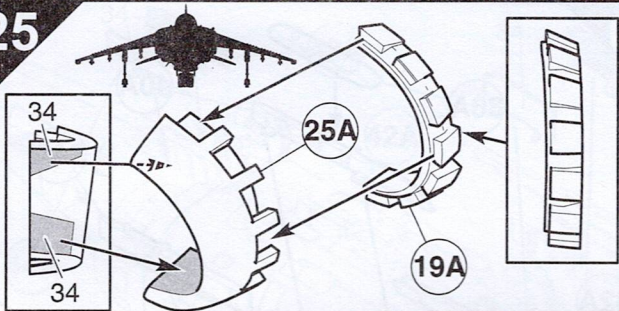

26

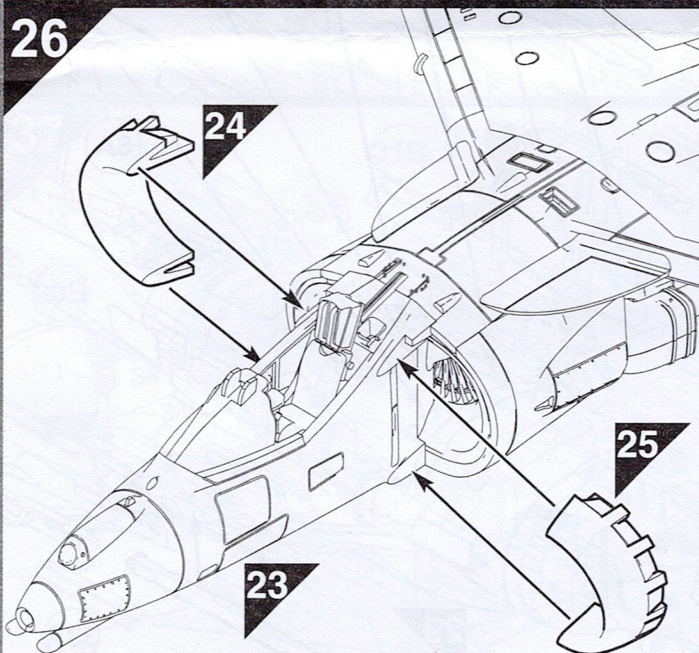

27

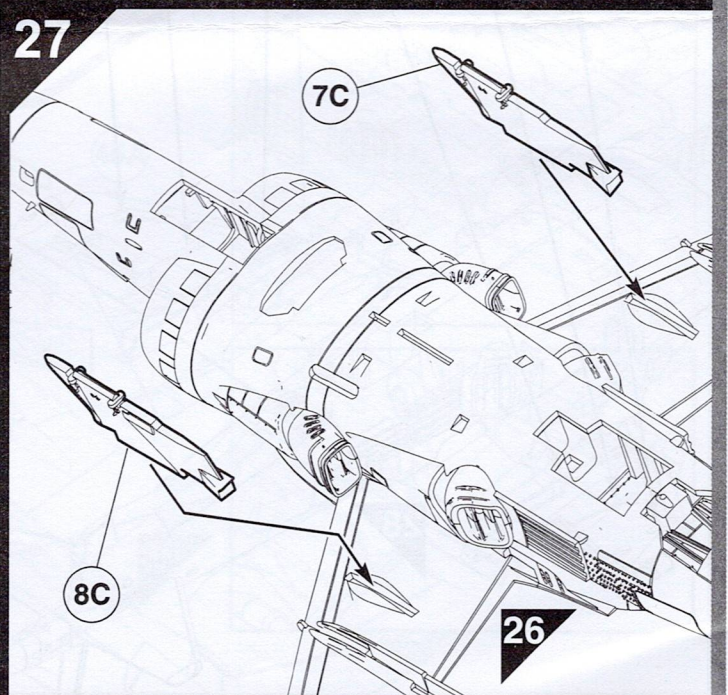



28

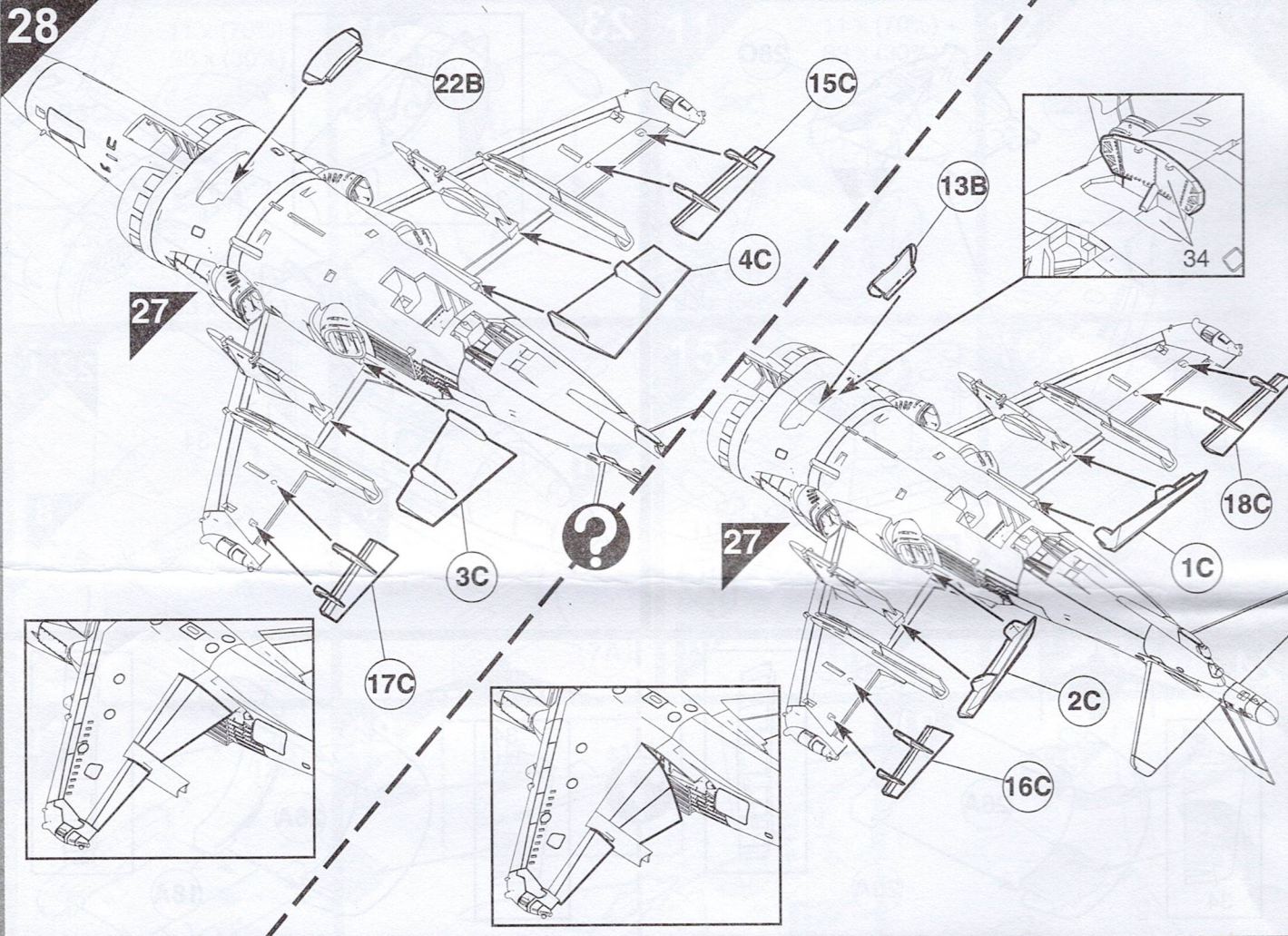

29

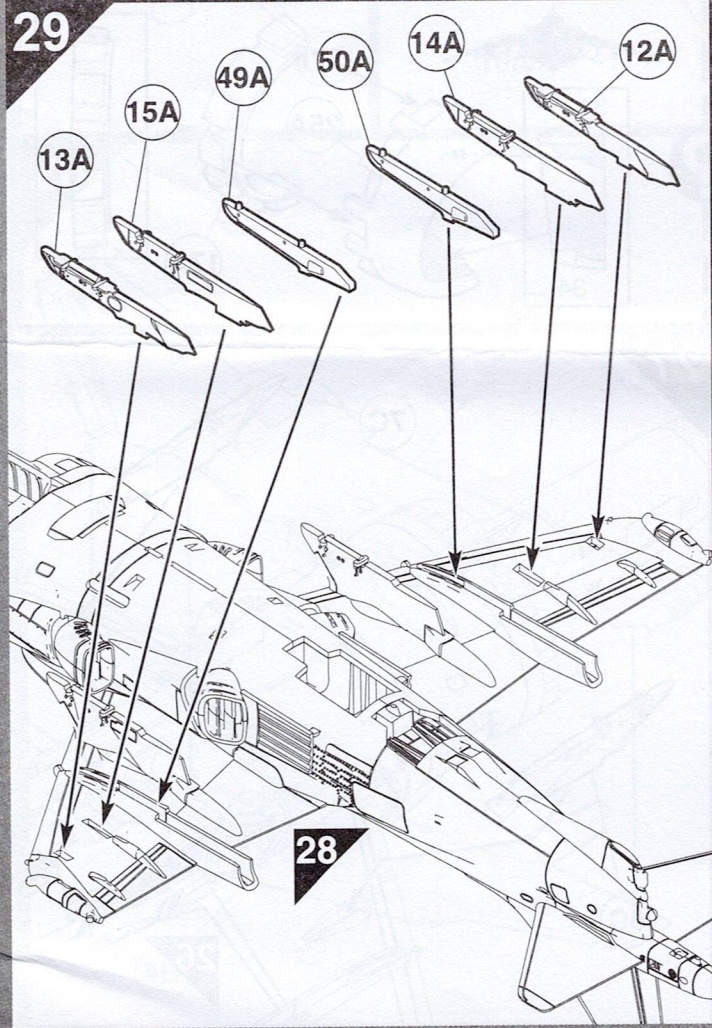

30

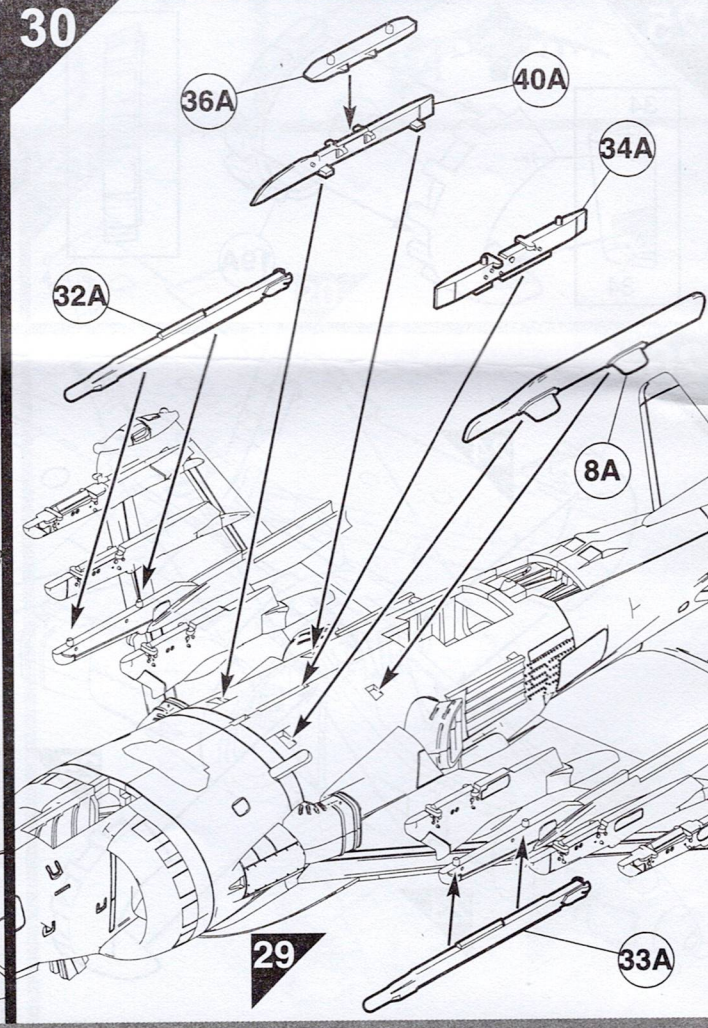



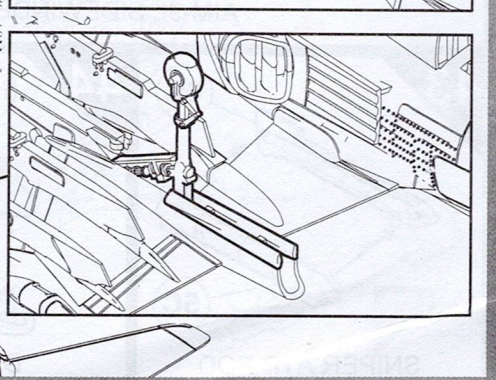
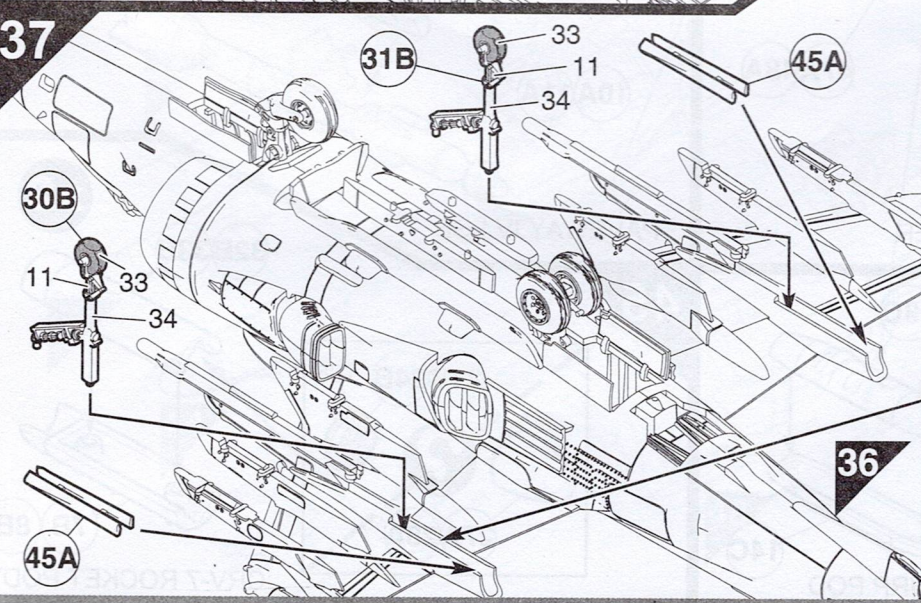
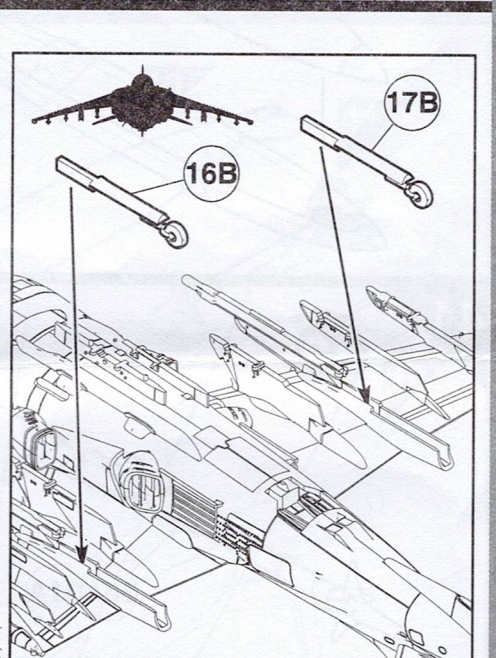
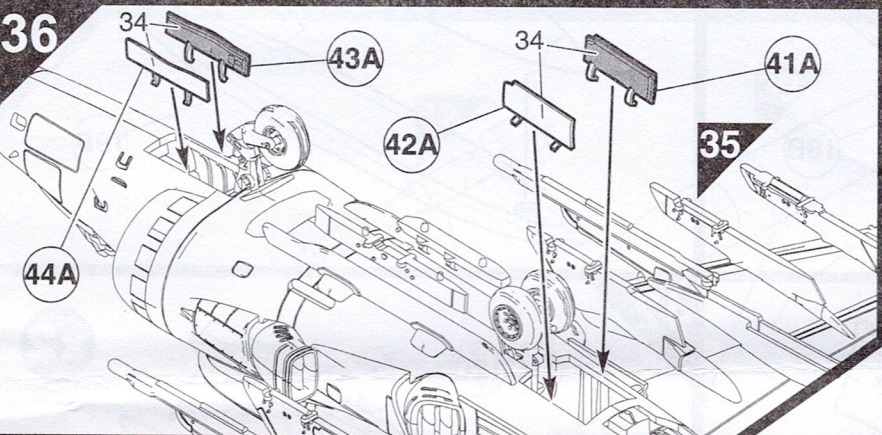
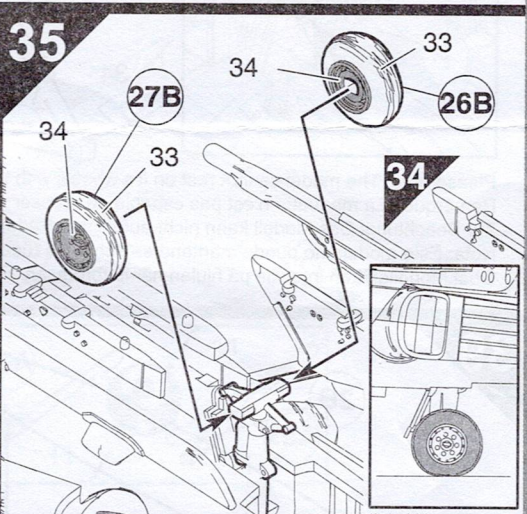
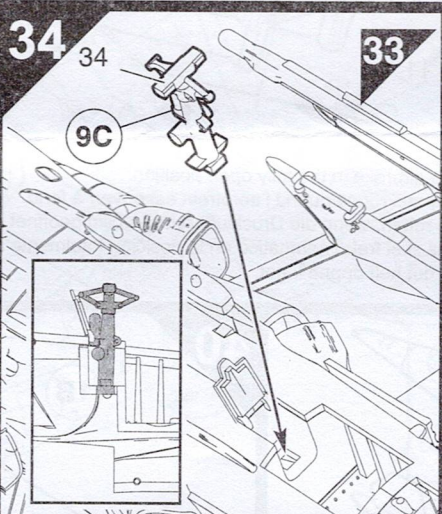
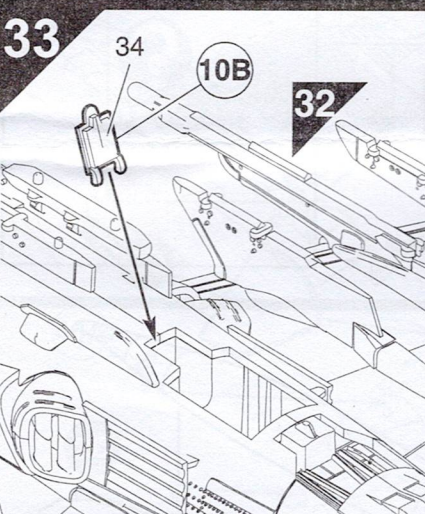
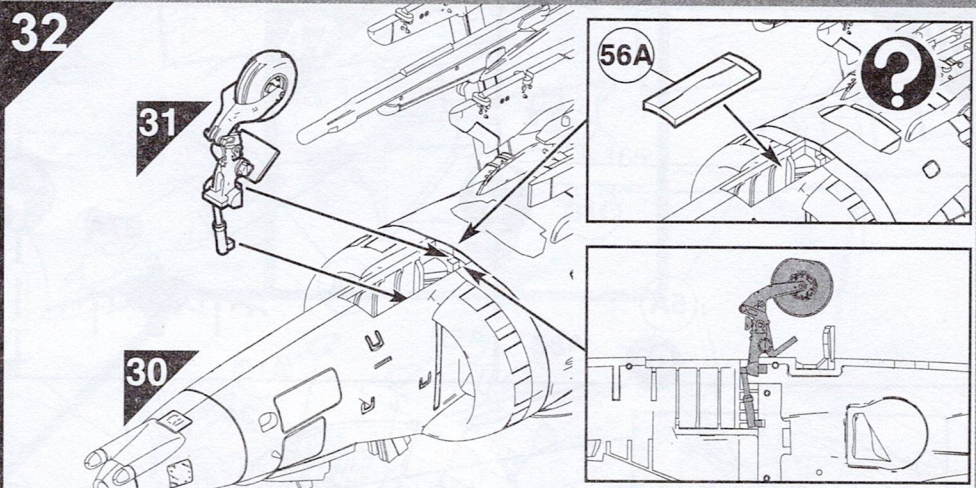
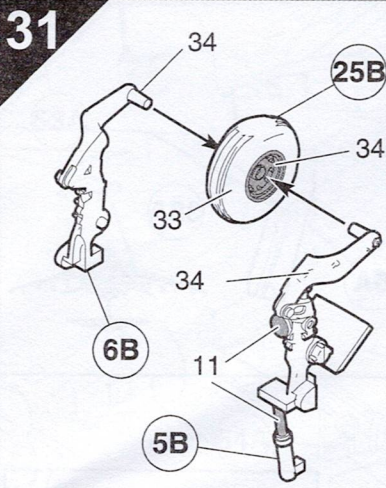



38

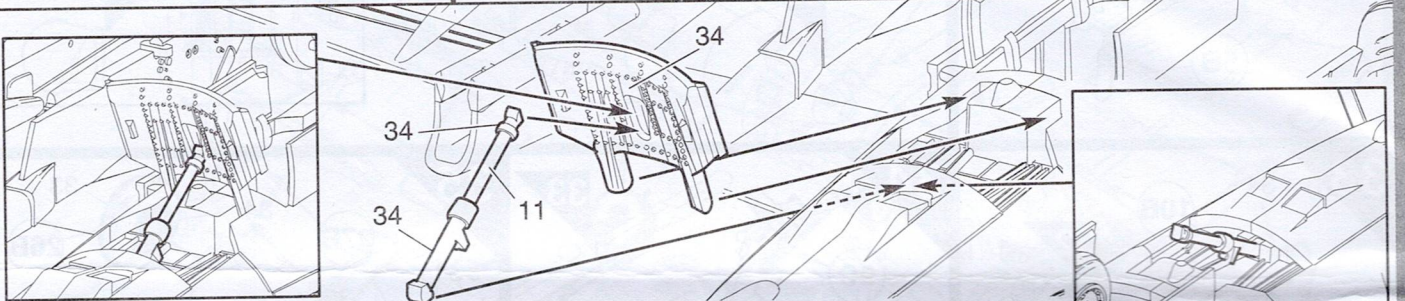
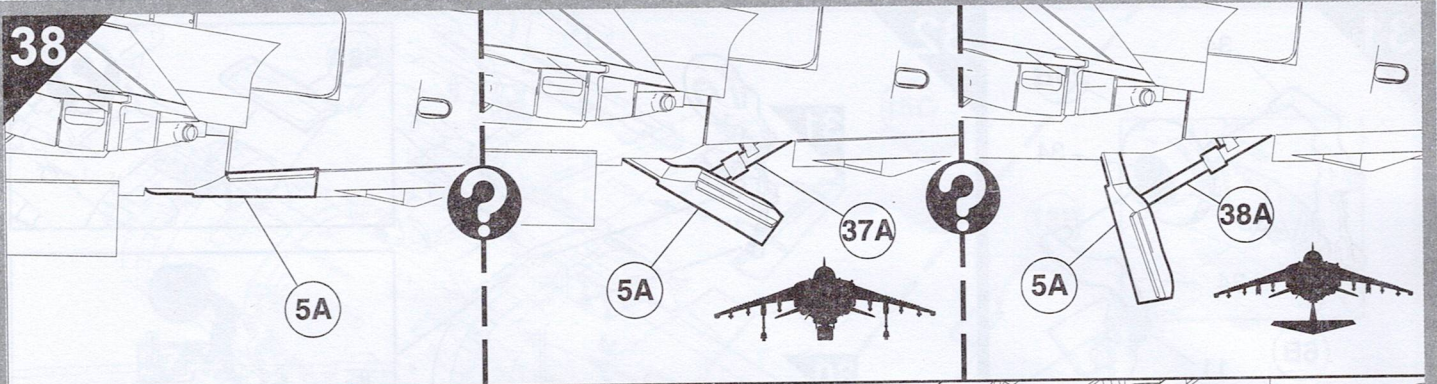

Please note: The model cannot rest on its wheels with the airbrake in the fully open position.  
 Remarque : La maquette n'est pas capable de reposer sur ses roues quand l'aéoréfrein est ouvert à fond.  
 Zur Beachtung: Das Modell kann nicht auf seinen Rädern ruhen, wenn die Druckluftbremse völlig geöffnet ist.  
 Nota: Este modelo no puede mantenerse sobre las ruedas si el freno neumático en la posición totalmente abierta.  
 Obs! Modellen kan inte vila på hjulen när luftbromsen är i det helt öppna läget.

39

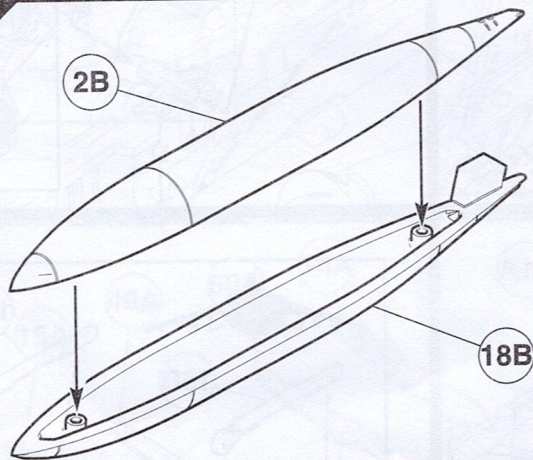

40

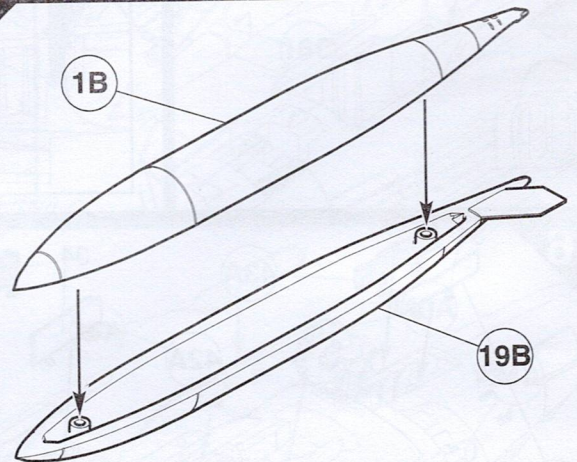

41

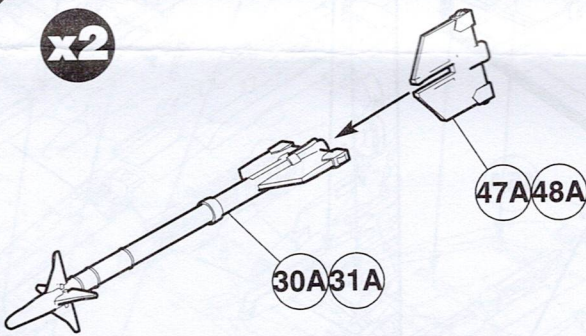

AIM-9L SIDEWINDER

42

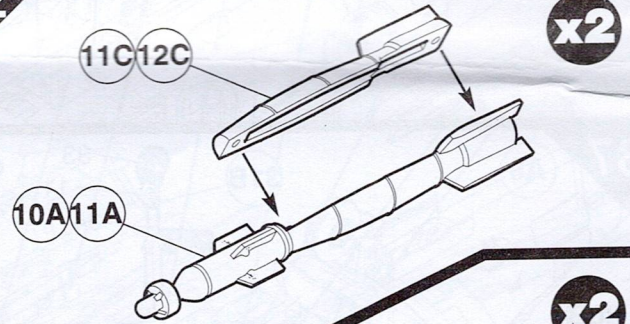

PAVEWAY IV LGB

43

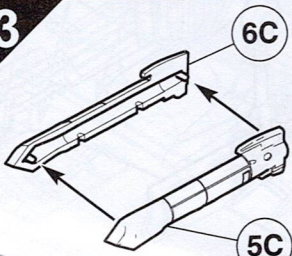

SNIPER ATP POD

44

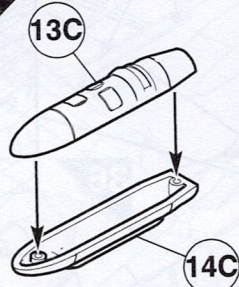

DJRP POD

45

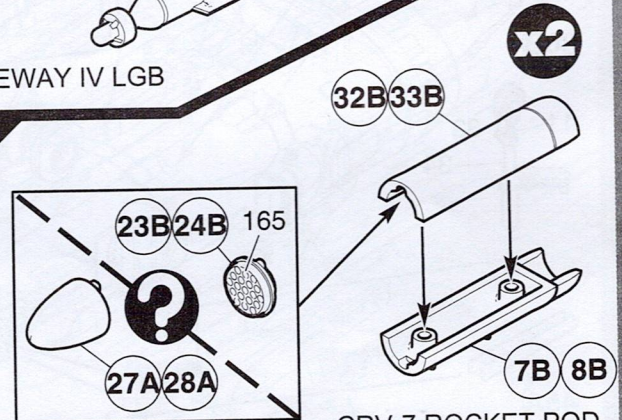

CRV-7 ROCKET POD



46

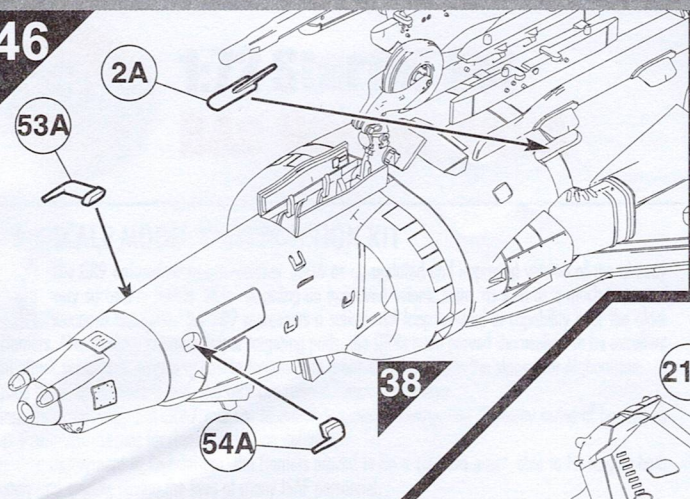

47

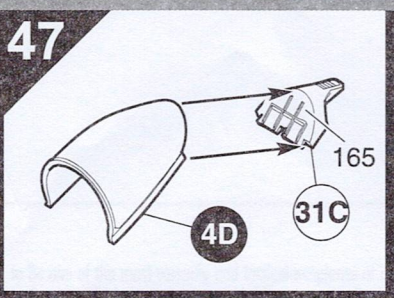

48

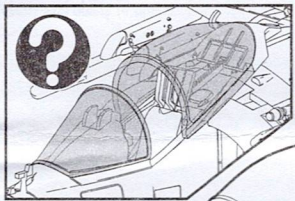

47

46

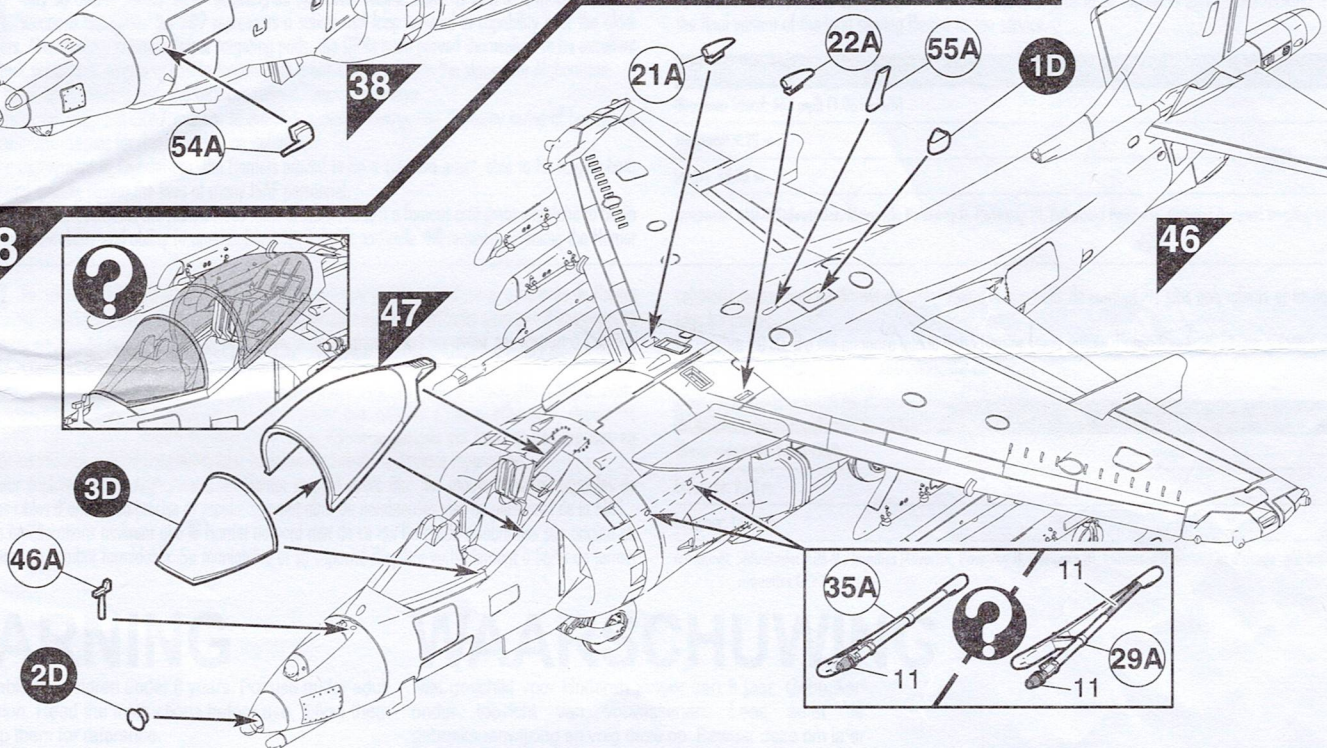

49

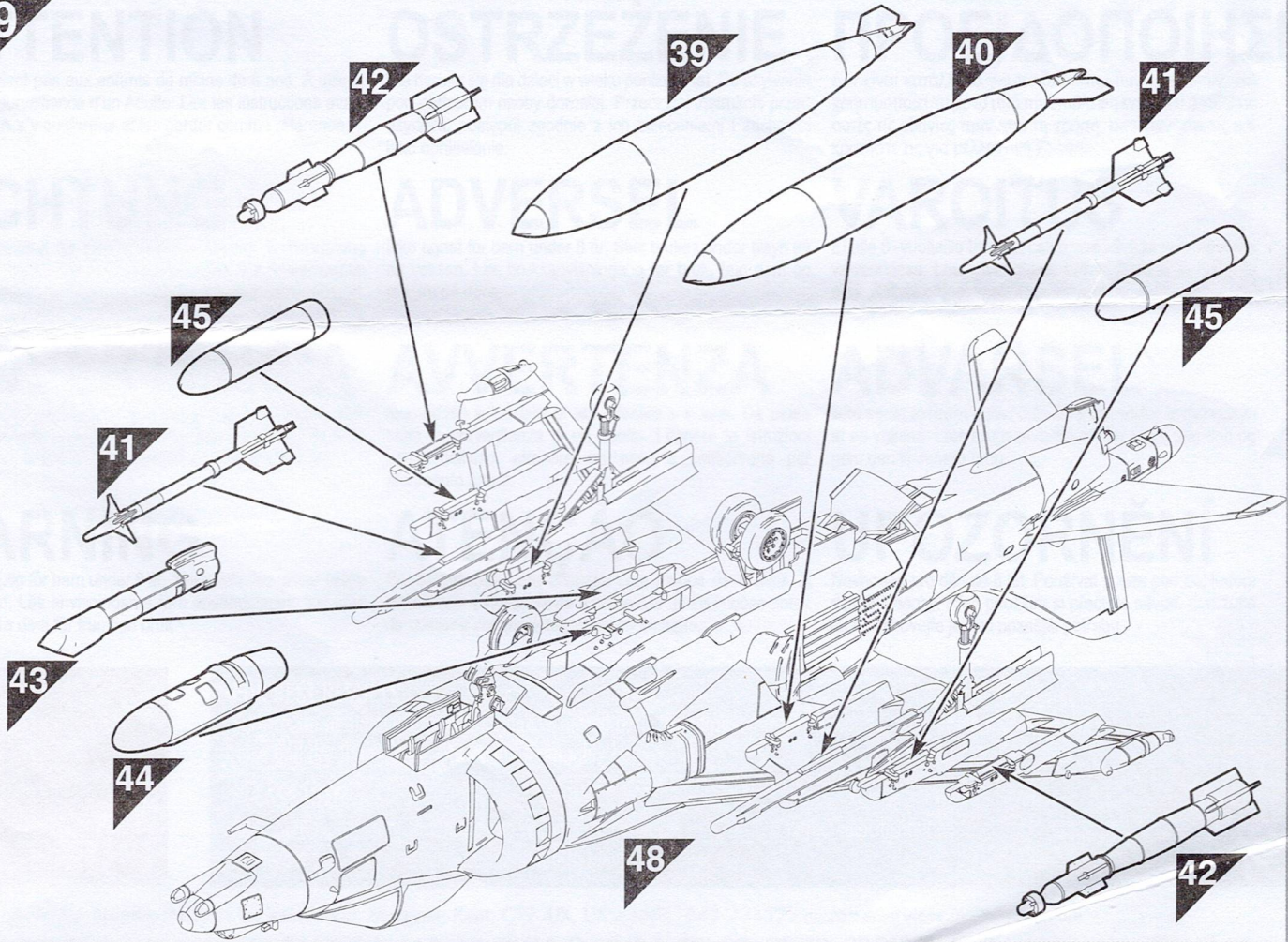



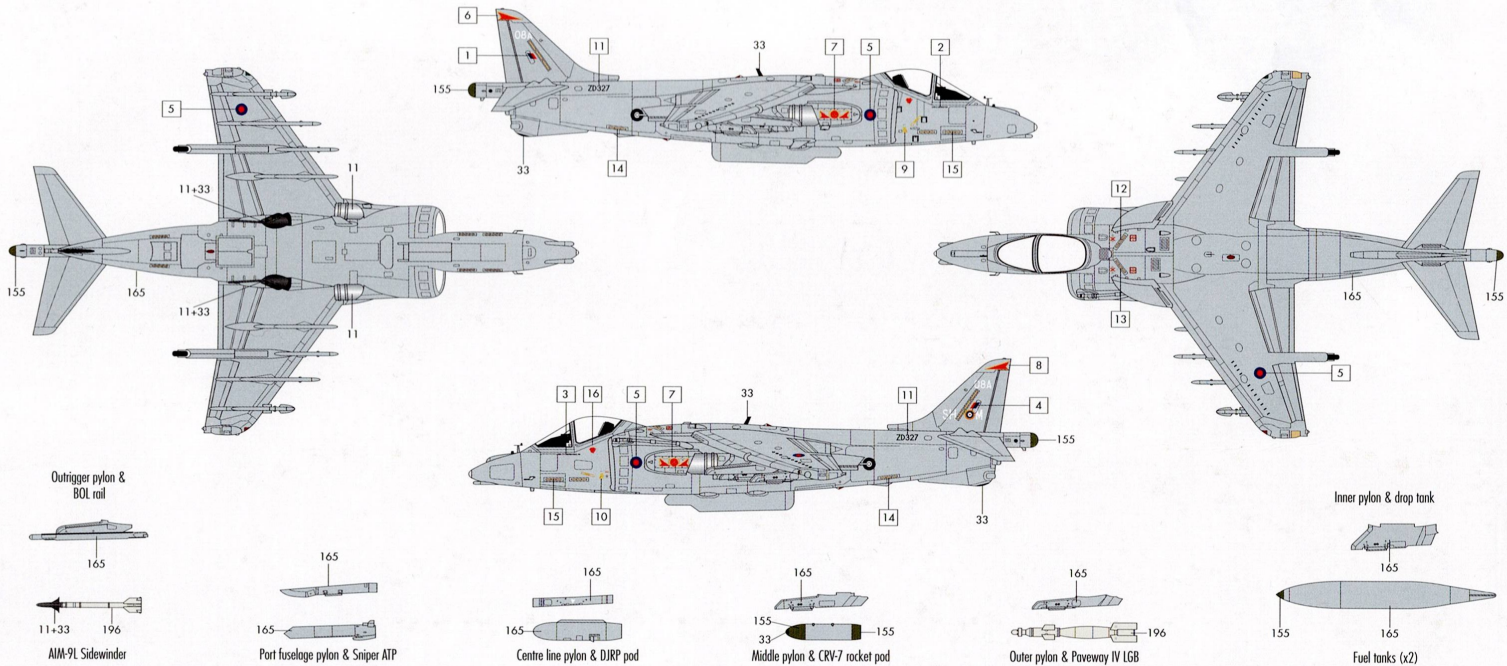

# PAINTING INSTRUCTIONS

**British Aerospace Harrier GR9A**  
 No. 800 Naval Air Squadron, Joint Strike Wing, Royal Air Force Cottesmore, 2010.

MIC07 PD1000490  
 A60300 24 026

