



# BOEING E-7 AEW&C

PLASTIC MODEL KIT 1/72

7225

✈ 461 mm ← 500 mm ❖ 218 pcs

## ENG

The Boeing E-7A is a twin-engine airborne early warning and control aircraft based on the Boeing 737 Next Generation design. It was designed for the Royal Australian Air Force (RAAF) under "Project Wedgetail".

It uses the Northrop Grumman Electronic Systems Multi-role Electronically Scanned Array (MESA) radar. The radar is capable of simultaneous air and sea search, fighter control and area search, with a maximum range of over 600 km (look-up mode). The E-7 has also been selected by the Turkish Air Force (under "Project Peace Eagle", Turkish: Barış Kartalı, designated E-7T), the Republic of Korea Air Force ("Project Peace Eye", Korean: 피스 아이), and the United Kingdom (designated Wedgetail AEW1). In April 2022, the United States Air Force announced that the E-7 will be replacing the E-3 beginning in 2027.

## technical data

Length: 33.63 m    Span: 35.8 m    Height: 12.55 m  
Max take-off weight: 77 600 kg    Cruising speed: 850 km/h  
Range: 4900 km    Crew: 8-12 persons  
Ceiling: 12 500 m

## UKR

Boeing E-7A — це двомоторний літак раннього попередження та управління на базі Boeing 737 Next Generation. Він був розроблений для Королівських ВПС Австралії (RAAF) у рамках "Проекту Wedgetail".

У ньому використовується багатоцільовий радар MESA (Multi-role Electronically Scanned Array) компанії Northrop Grumman Electronic Systems. Радар здатний здійснювати одночасний повітряний і морський пошук, управління винищувачем і пошук місцевості з максимальною дальністю понад 600 км (режим огляду). E-7 також був обраний ВПС Туреччини (під «Проектом Орел Миру», турецькою: Barış Kartalı, позначається E-7T), ВПС Республіки Корея («Проект Око Миру», корейською: «피스 아이») і Сполучене Королівство (з позначенням Wedgetail AEW1). У квітні 2022 року ВПС США оголосили, що E-7 замінить E-3, починаючи з 2027 року.

## технічні характеристики

Довжина: 33,63 м    Розмах: 35,8 м    Висота: 12,55 м  
Максимальна злітна вага: 77 600 кг    Крейсерська швидкість: 850 км/год.  
Дальність: 4900 км    Екіпаж: 8-12 чол.  
Фактична стеля: 12 500 м

## assembly symbols / спеціальні умовні позначки для збирання



assembly options

варіанти збирання



use CA glue

використати «суперклей»



do not cement

не клеїти



bend part

зігнути деталь



multiple times assembly

зібрати кілька



drill a hole

просверлити отвір



symmetrical assembly

симетричне збирання



cut to fit / cut out

відрізати / прорізати

<b>A</b>	White Білий	H1 1 71.001
<b>B</b>	Flat Black Чорний Матовий	H12 33 71.057
<b>C</b>	Light Grey (FS 36495) Світло-сірий	H338 338 71.276
<b>D</b>	Grey (FS 36270) Сірий нейтральний	H303 306 71.275
<b>E</b>	Grey (FS 36118) Сірий	H305 305 71.097
<b>F</b>	Green (FS 34227) Зелений	H312 312 71.126
<b>G</b>	Shine Silver / Chrome Сріблястий / Хром	H8 90 77.707
<b>H</b>	Burnt Iron Палений метал	H76 61 77.721
<b>I</b>	Steel Сталь	H18 28 77.712
<b>J</b>	Tire Black Гума	H77 137 71.315
<b>K</b>	Light Grey + White Світло-сірий + Білий	H338 338 71.276 H1 1 71.001
<b>L</b>	Clear Red Прозорий червоний	H90 47 70.934
<b>M</b>	Red Червоний	H3 3 70.945
<b>N</b>	Clear Green Прозорий зелений	H92 138 70.936

\* MTR новий  
vallejo COLORS H304 304  
vallejo COLORS 72.000

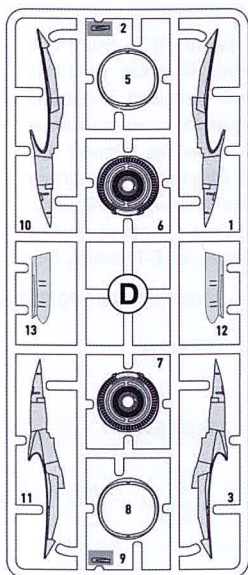
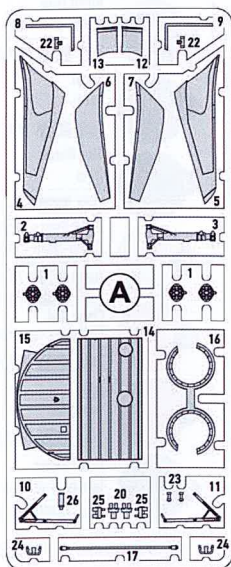
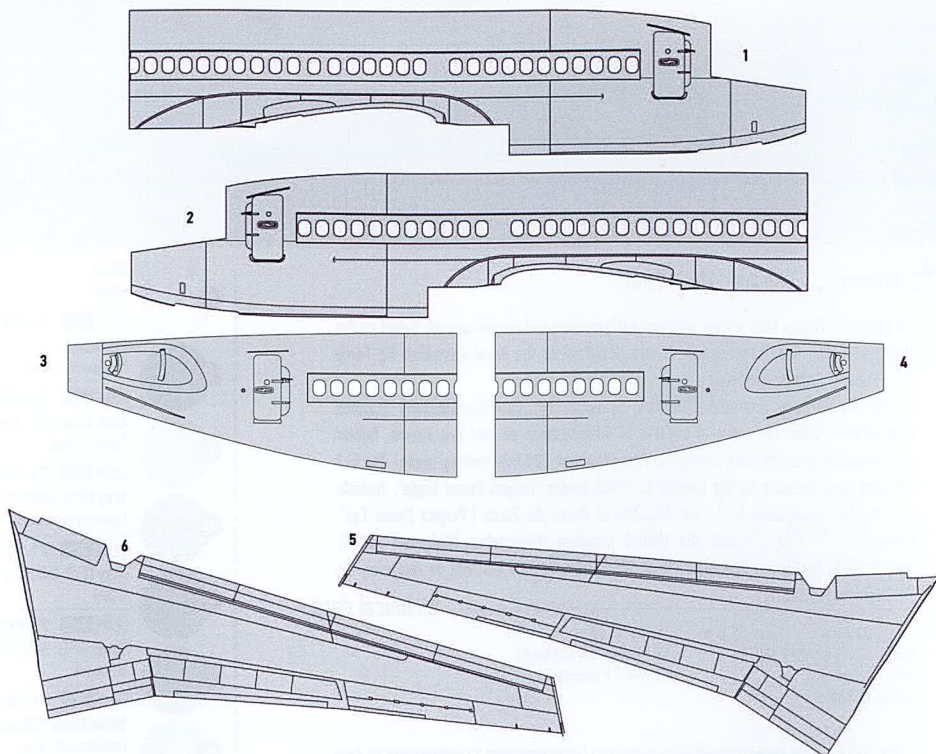

do not use / не використовувати

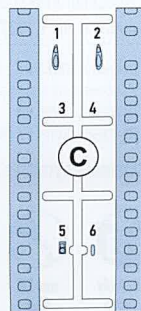
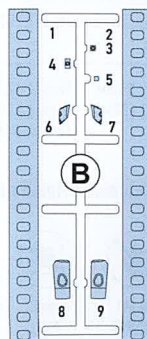
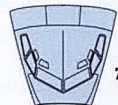

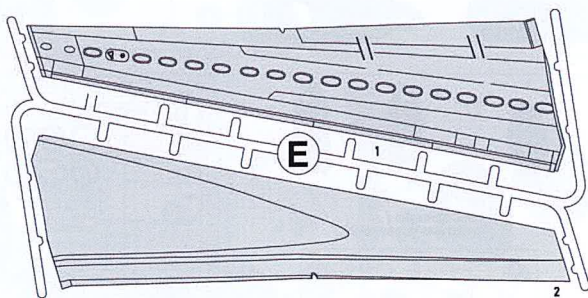
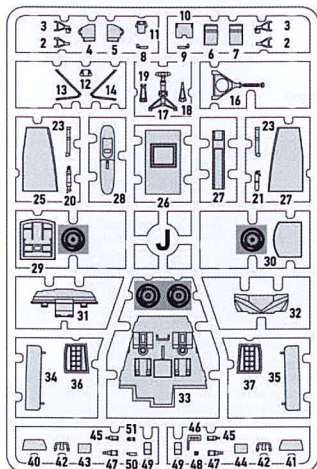
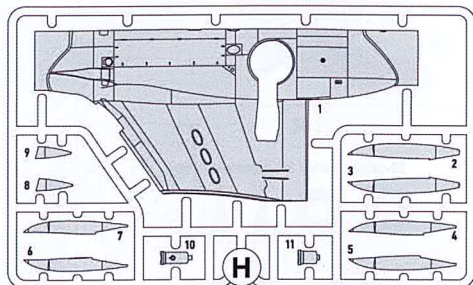
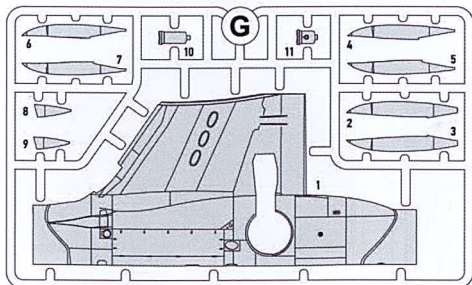
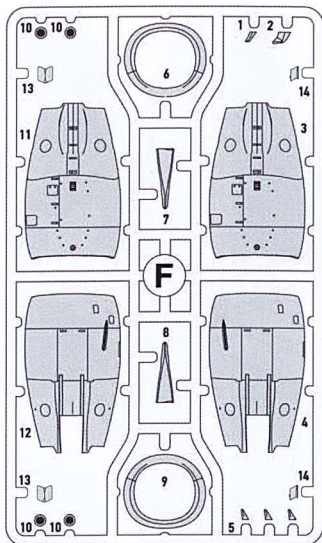
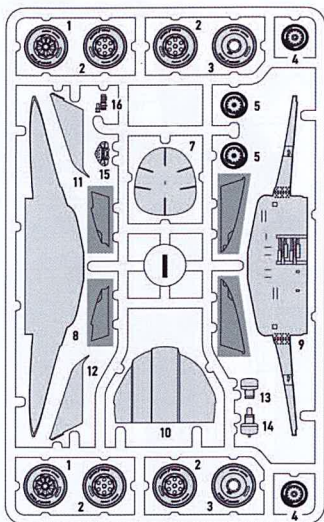

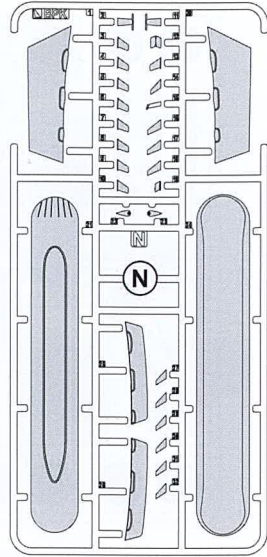
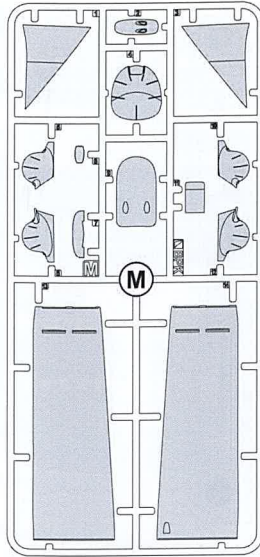
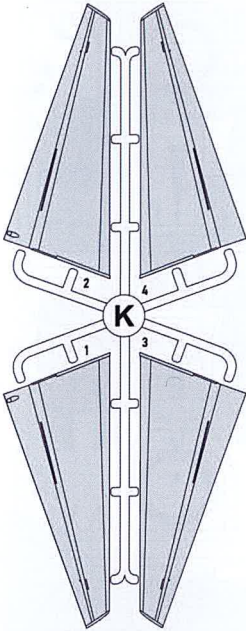

**R**

3D-printed parts / 3D-друковані деталі

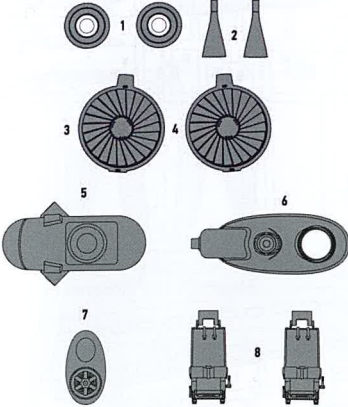

painting masks / маски для фарбування

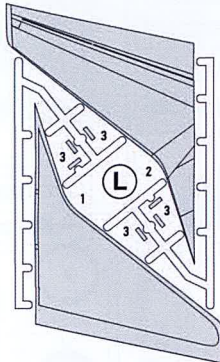
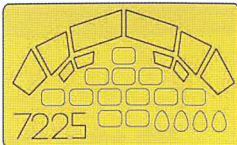
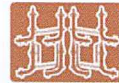
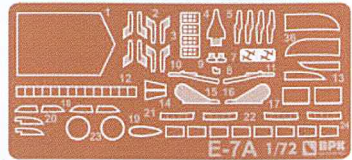
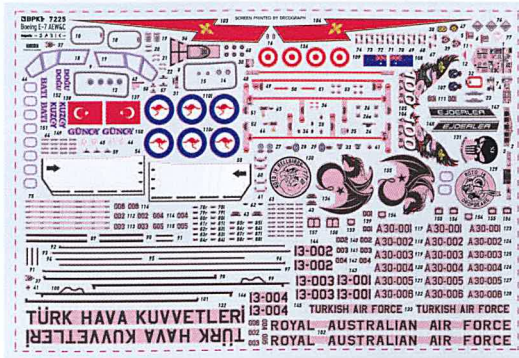
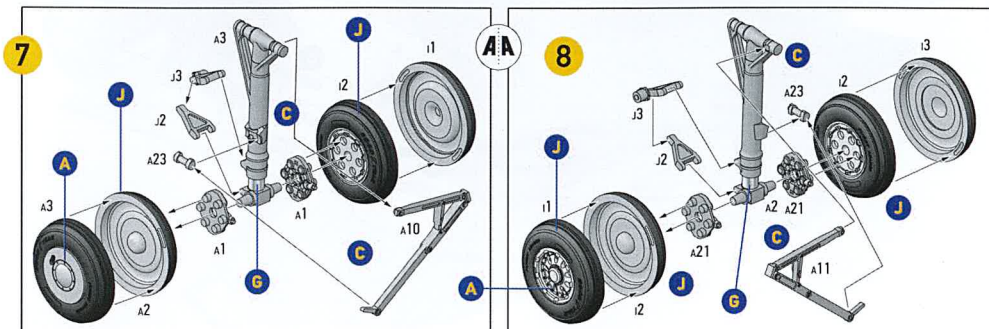
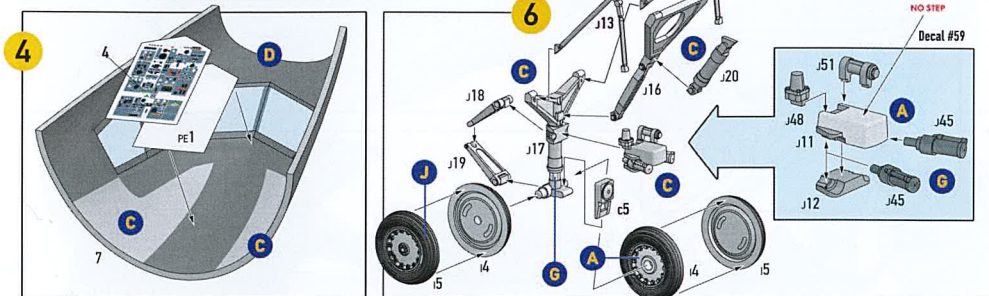
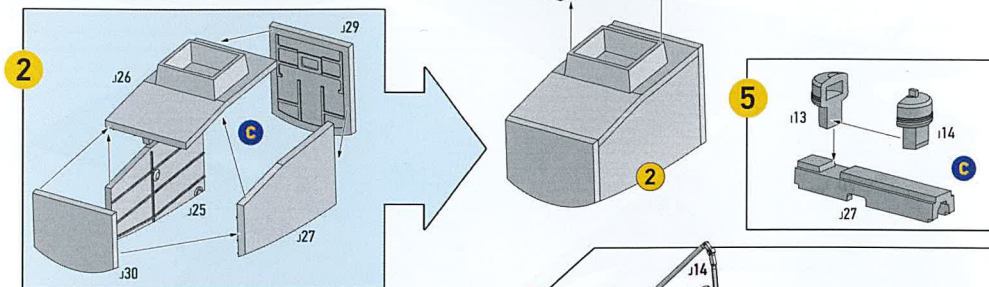
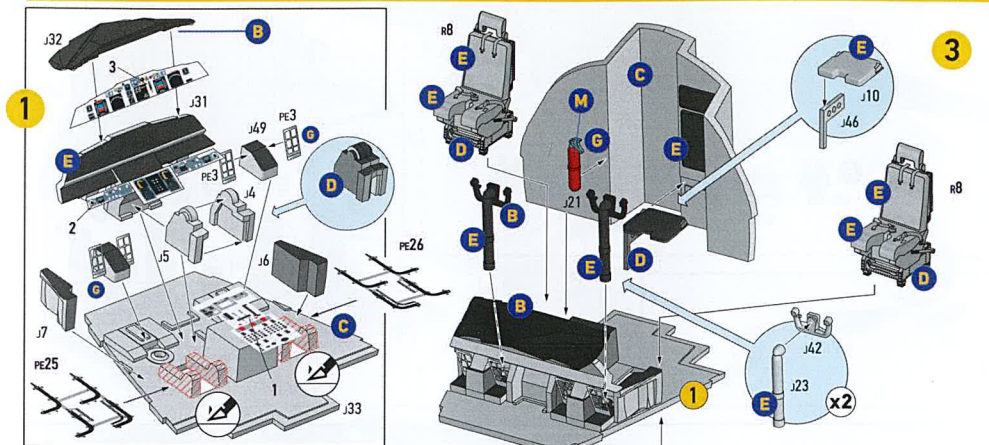

photo etched parts / фототравлені деталі



decals / декалі





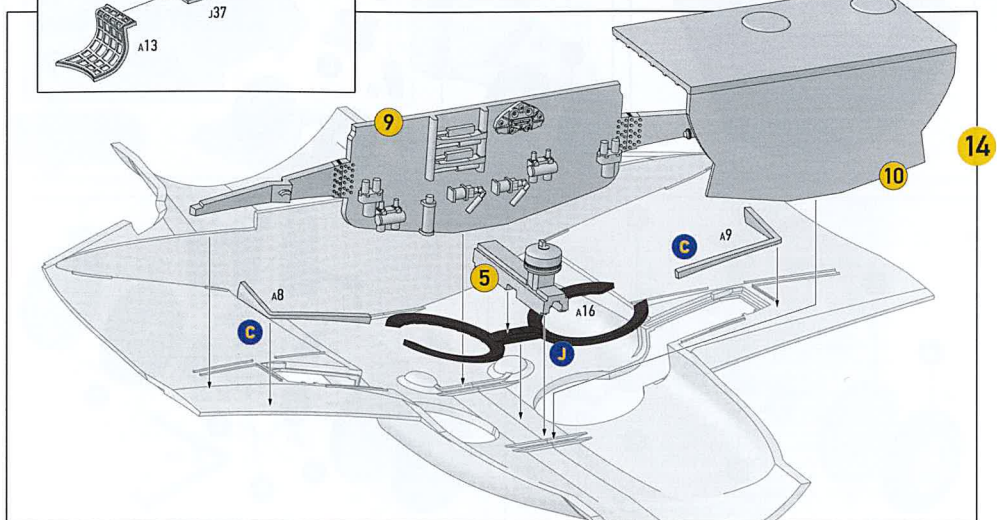
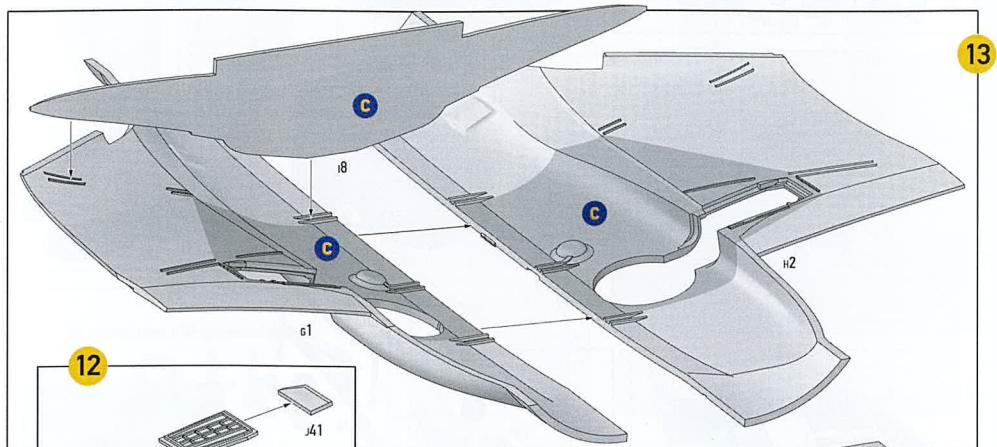
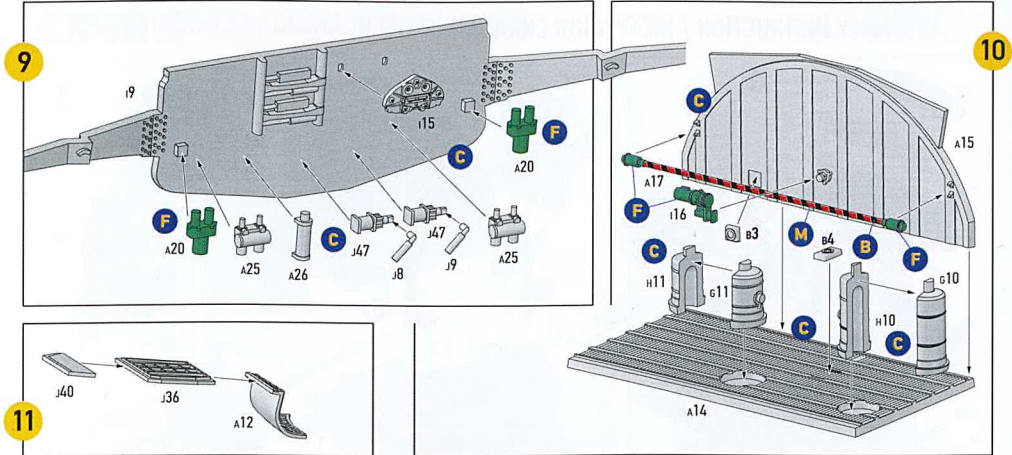

15

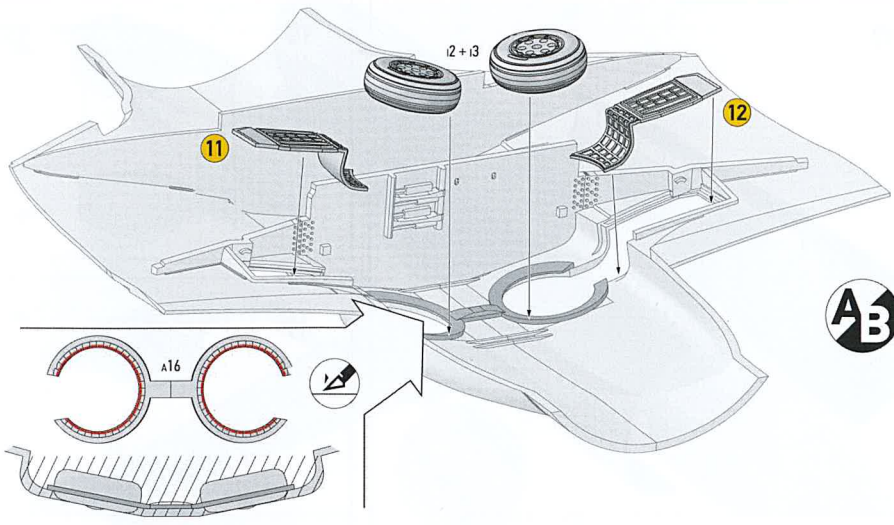

16

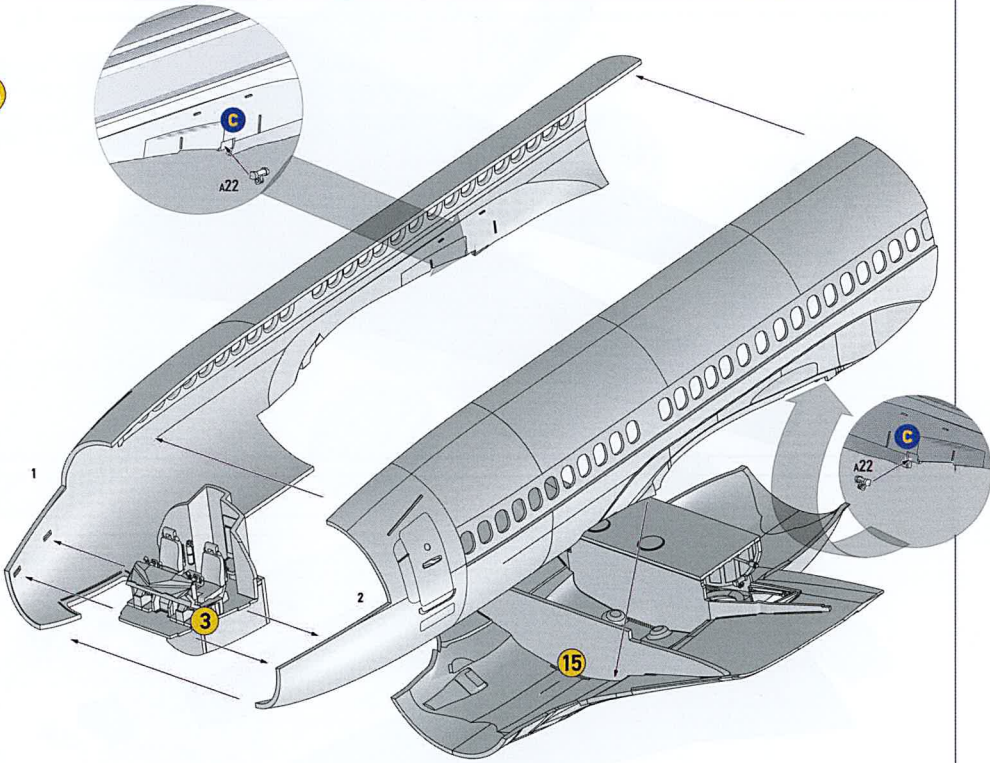

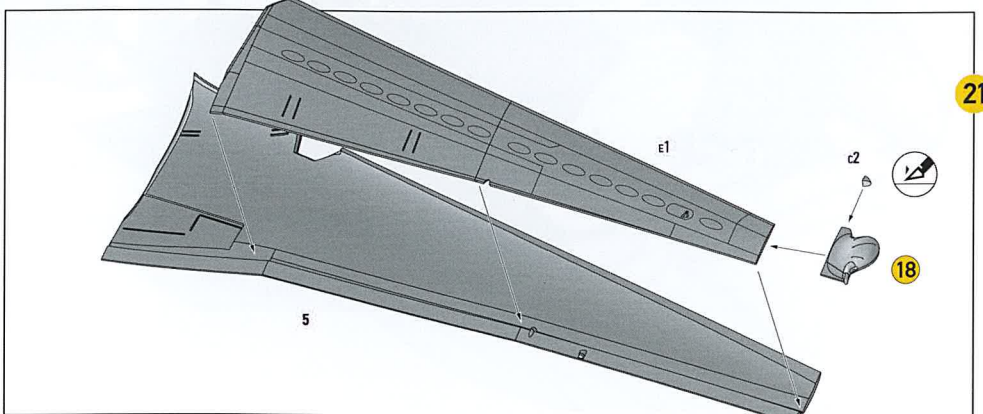
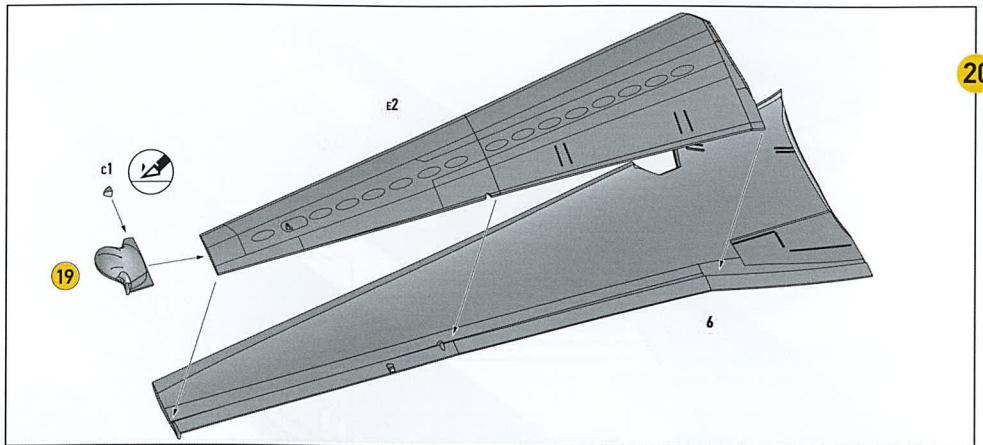
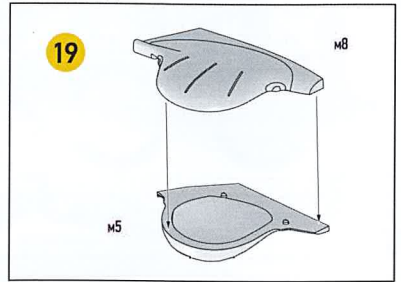
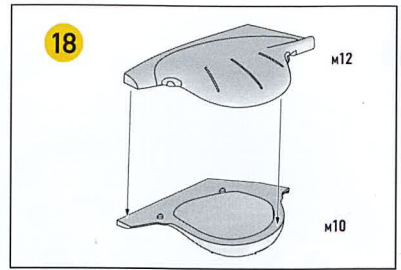
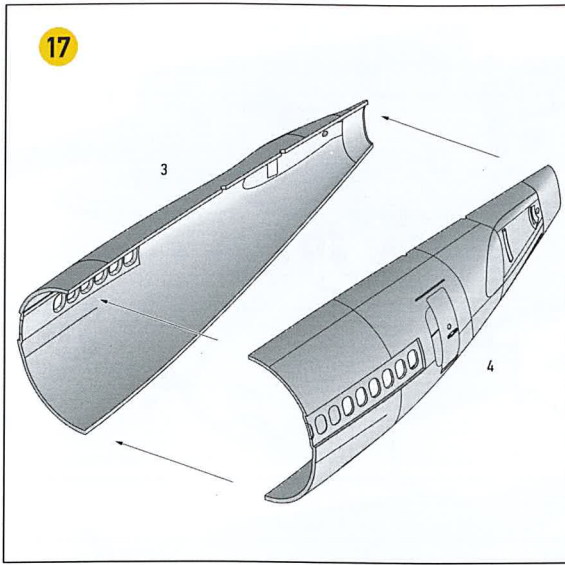



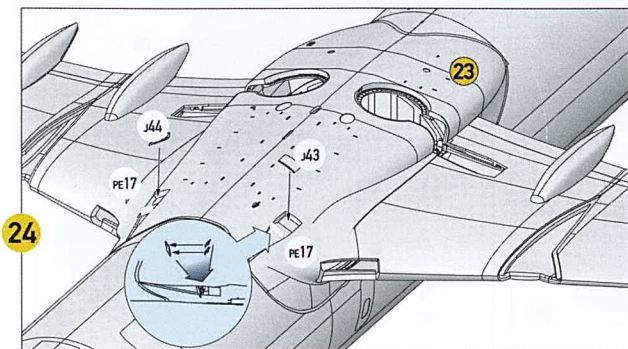
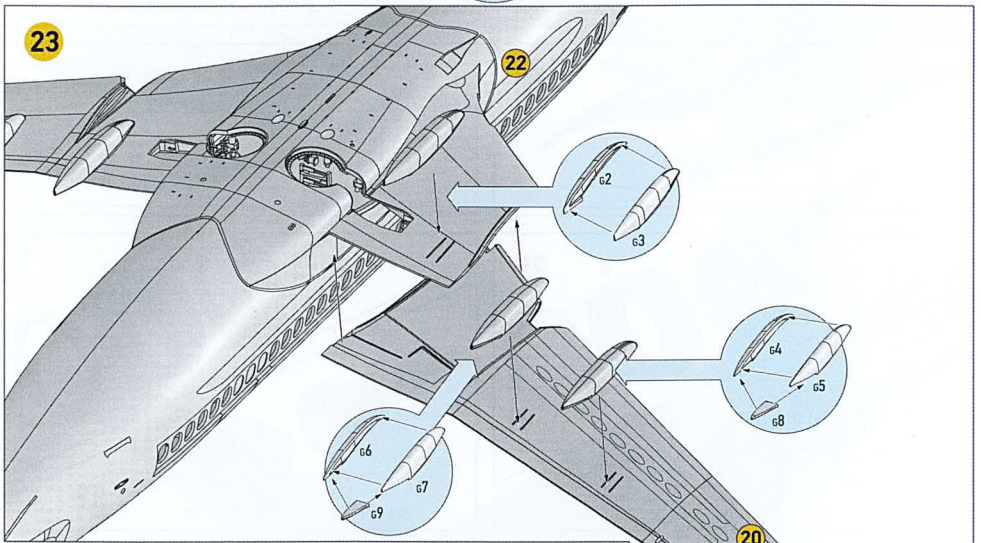
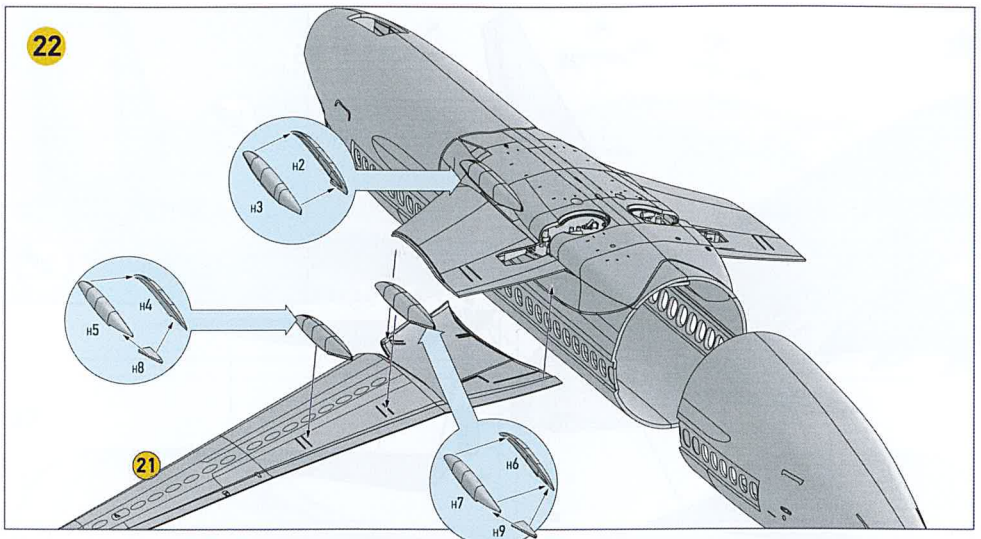

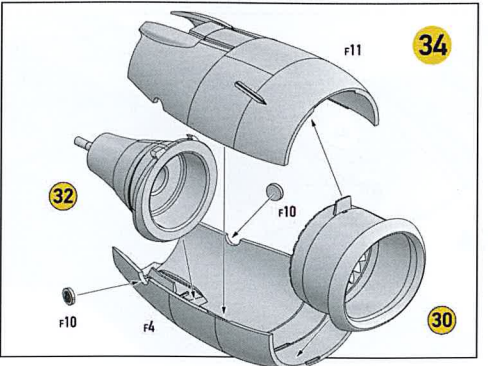
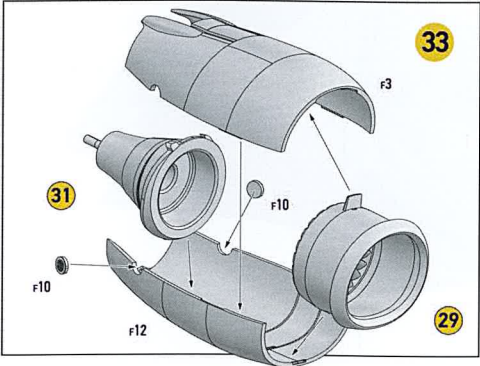
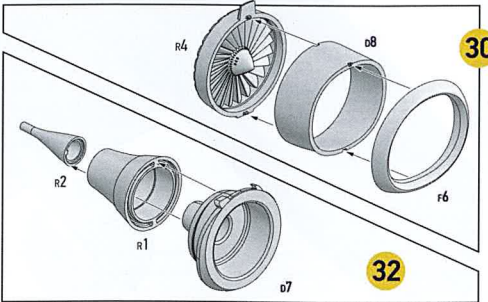
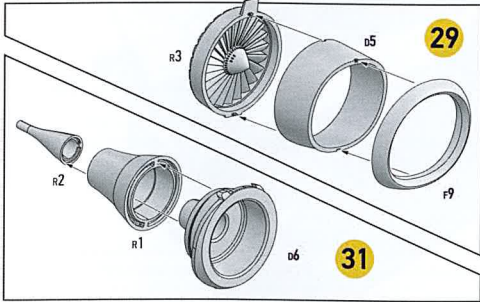
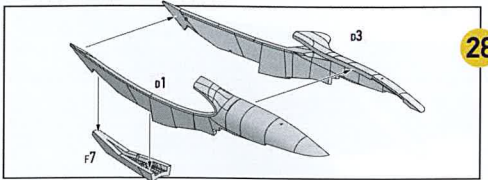
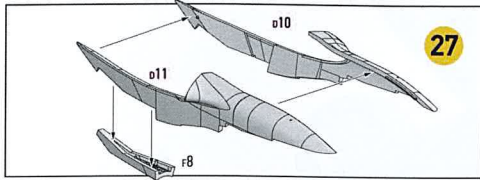
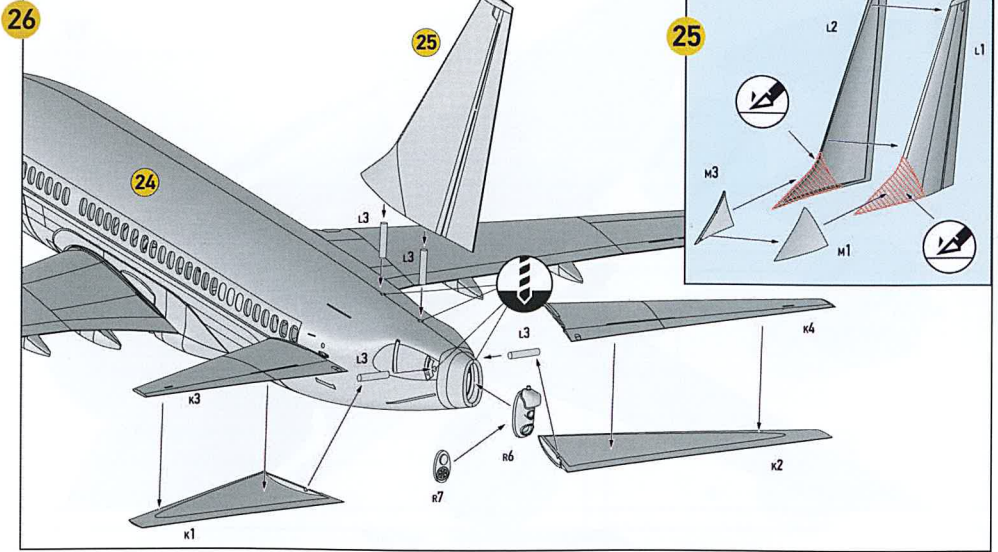

35

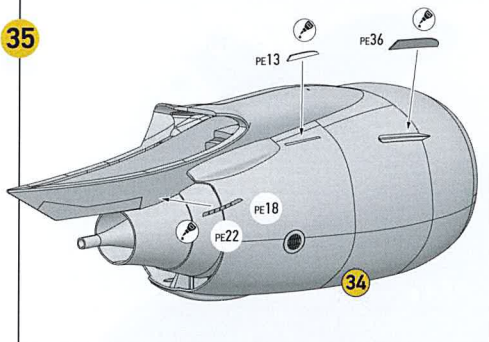

36

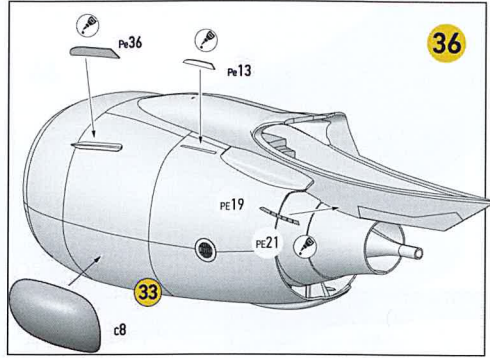

37

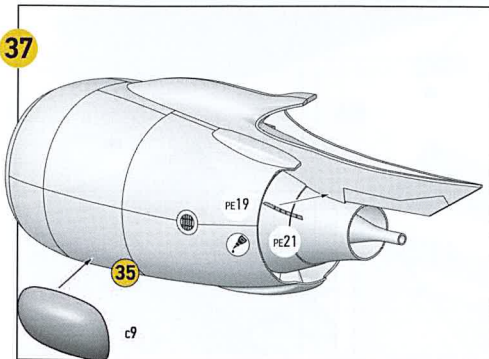

38

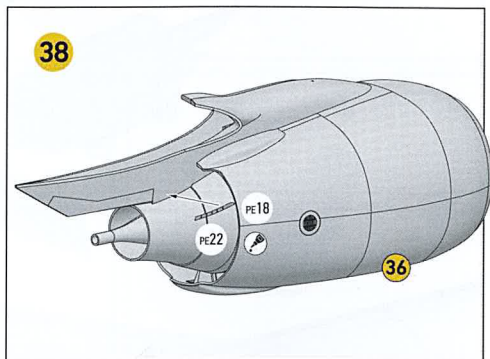

39

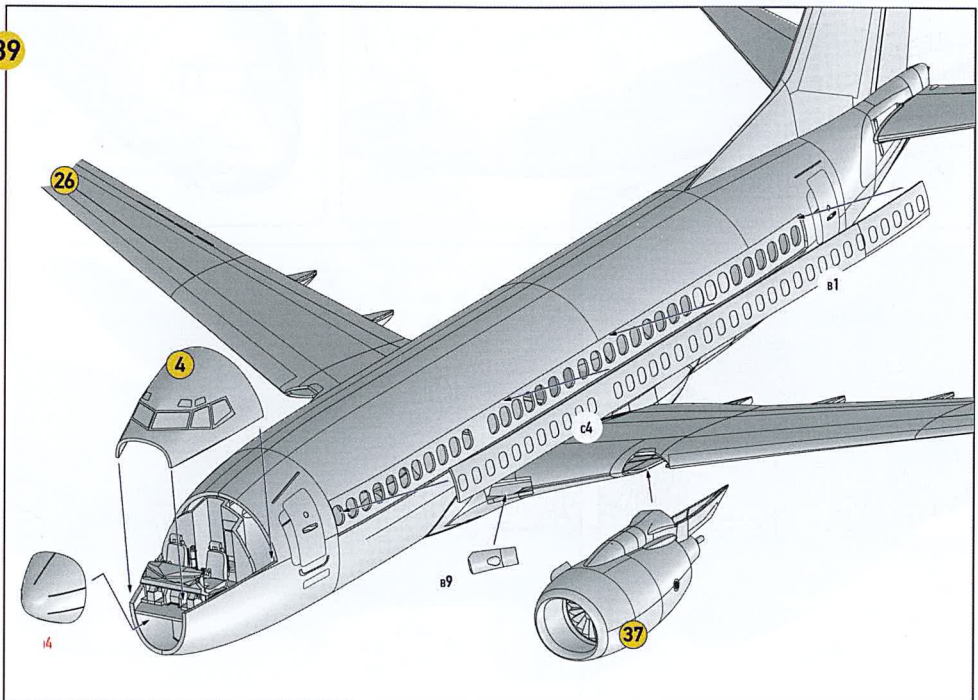

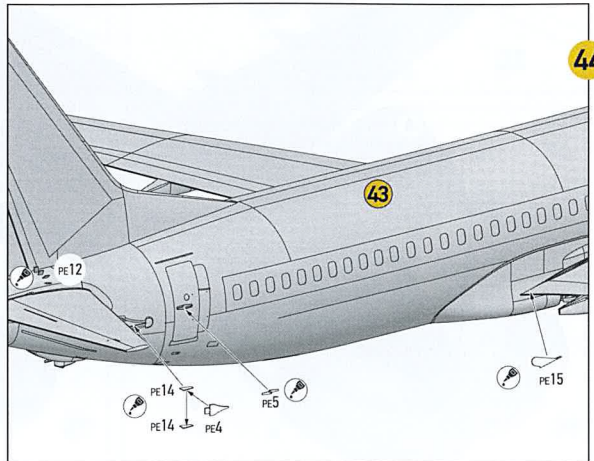
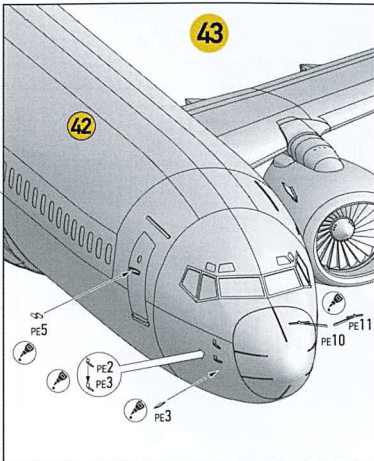
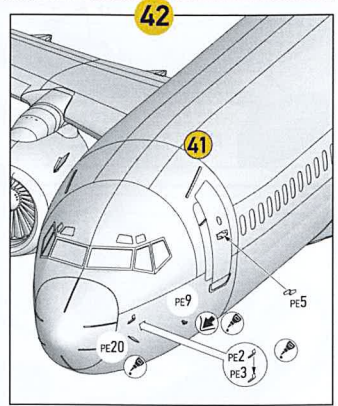
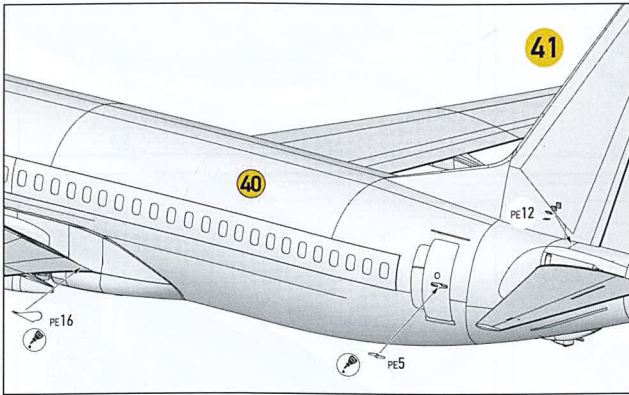
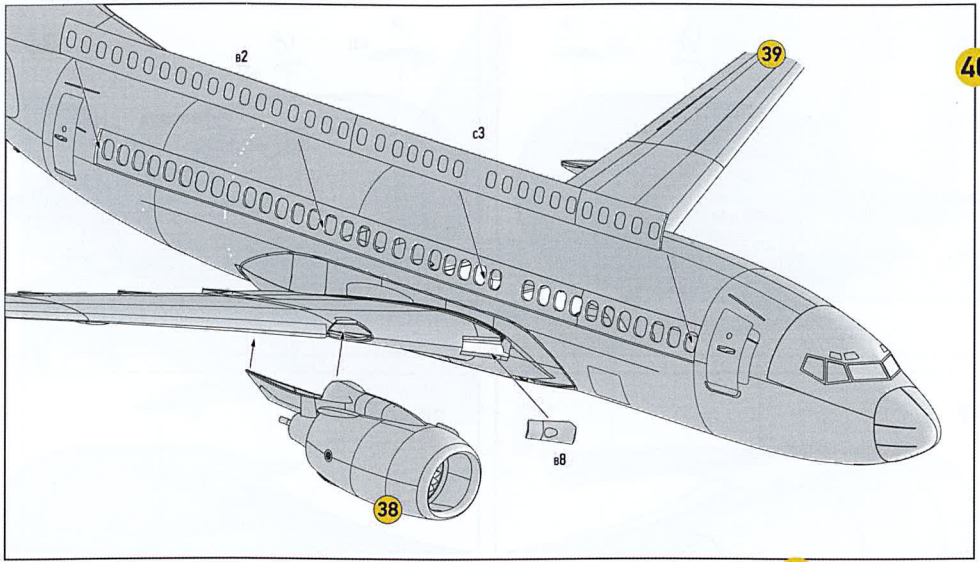

45

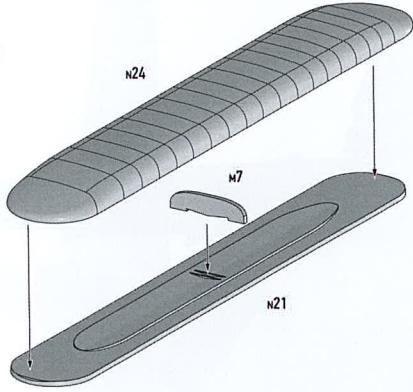

46

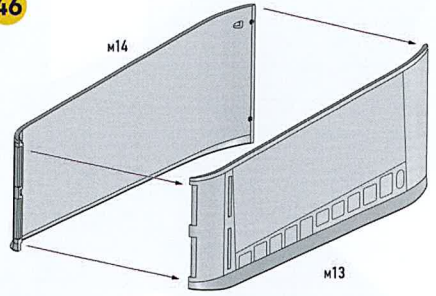

47

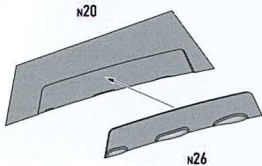

48

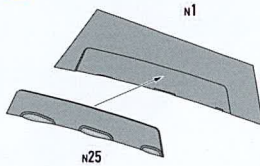

49

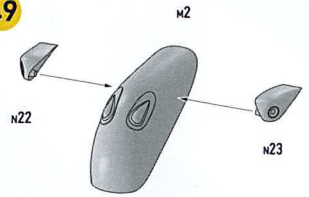

50

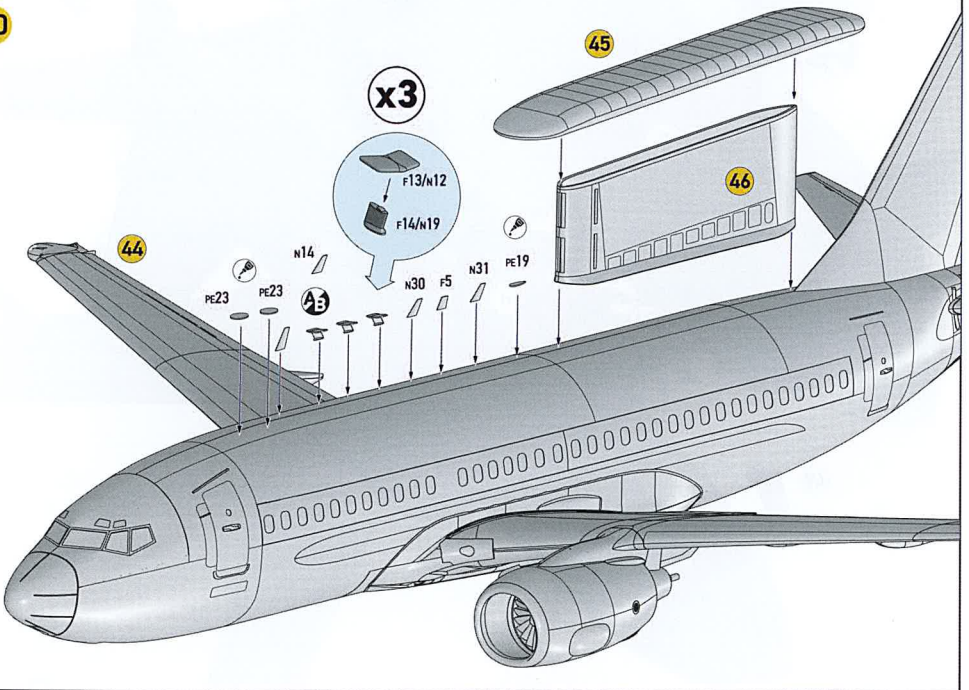

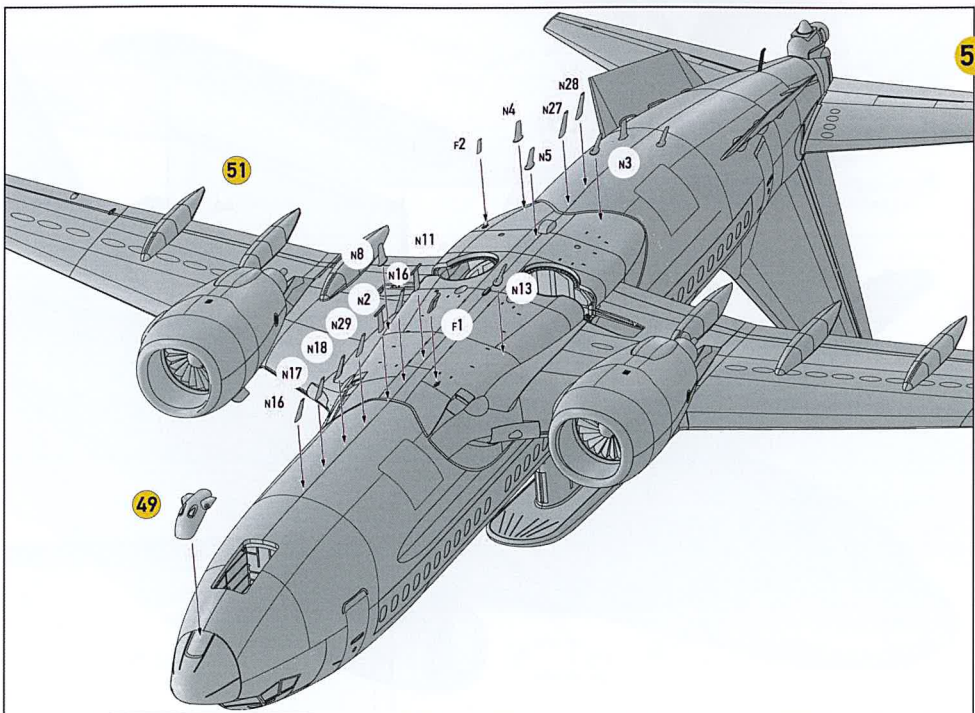
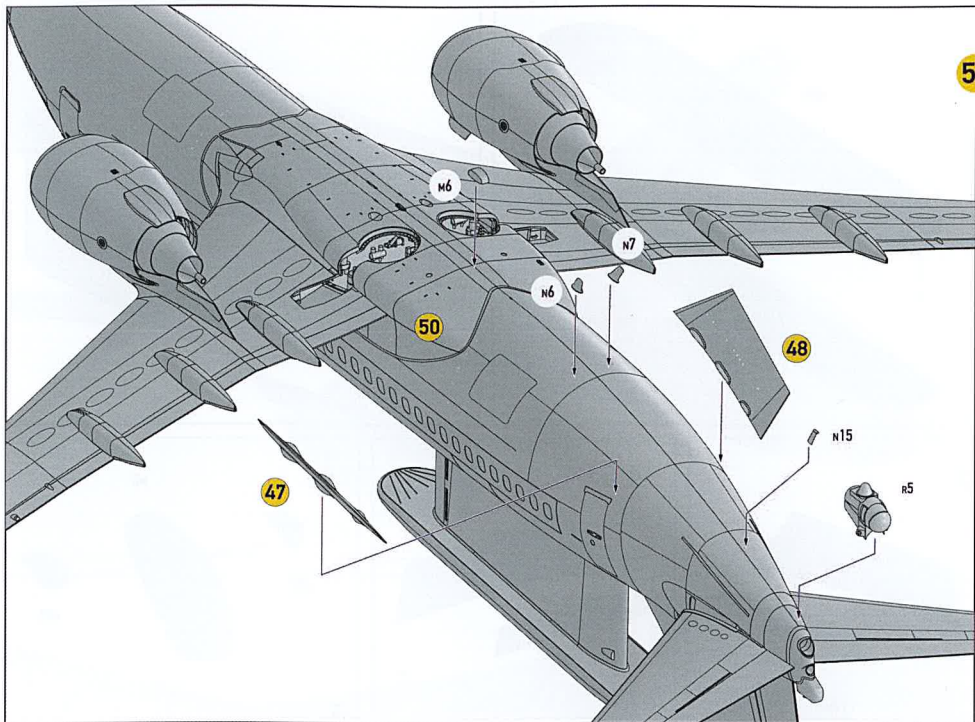

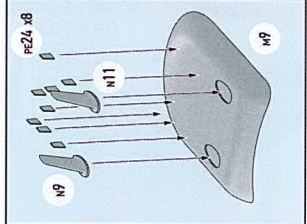
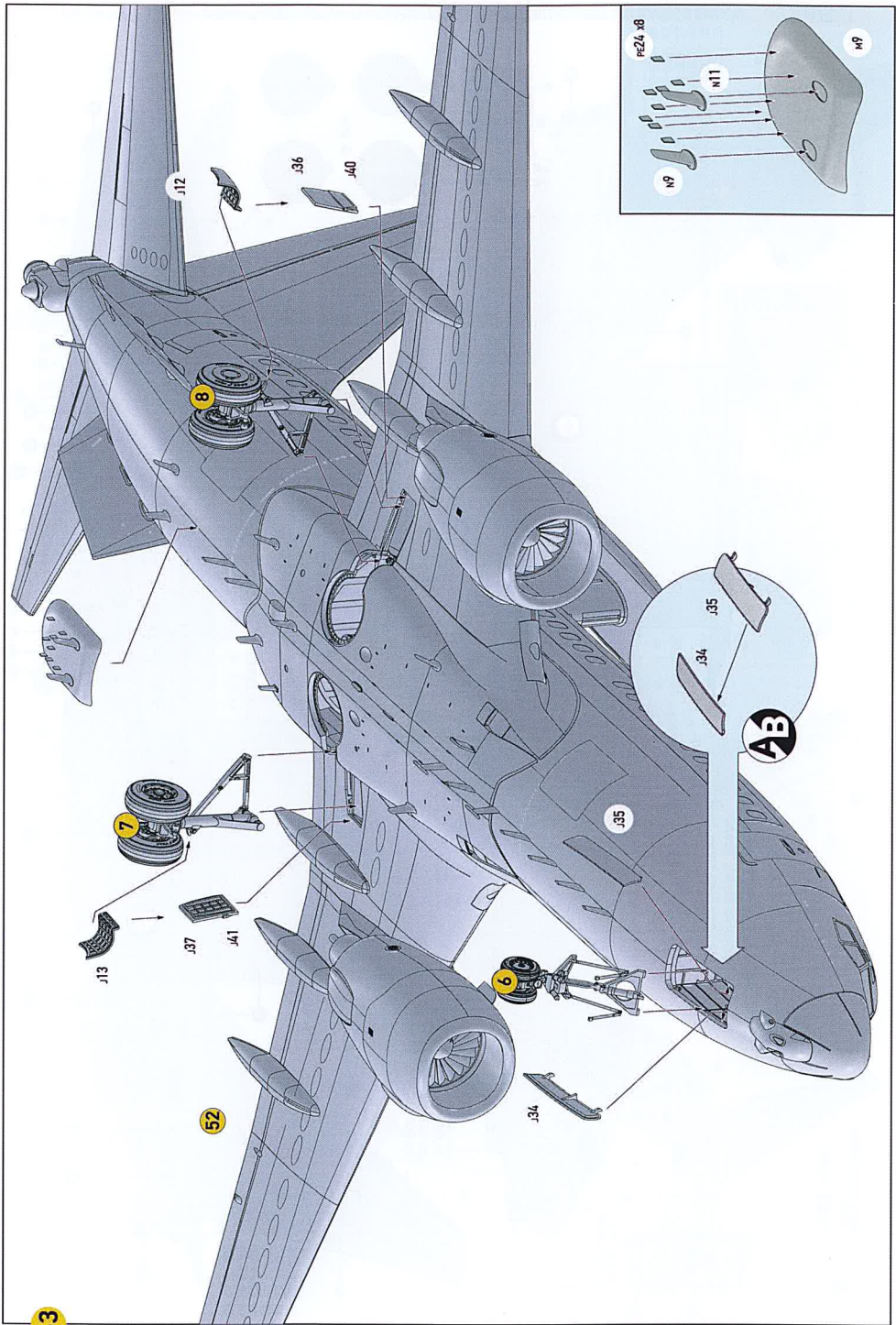

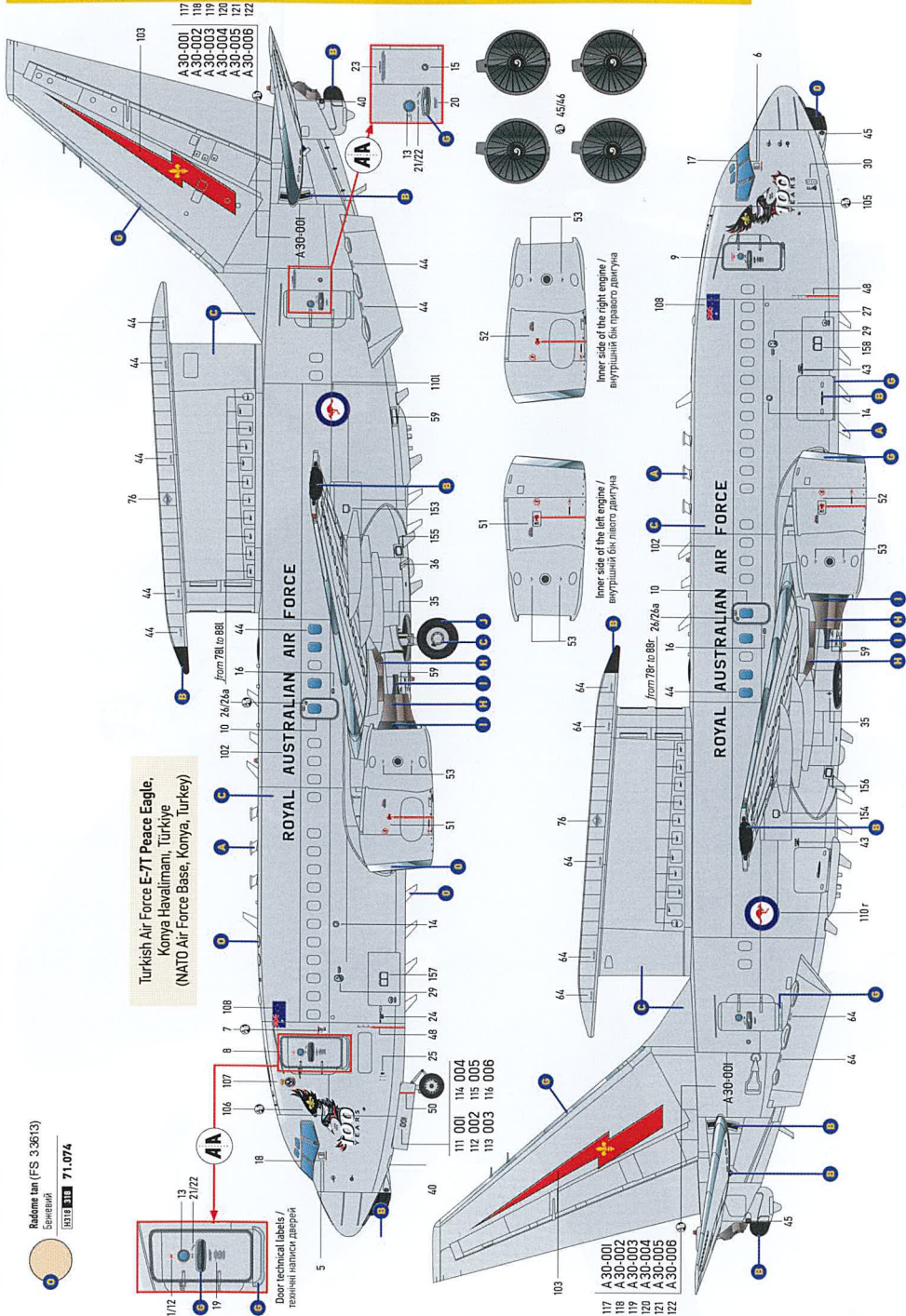

Radome fan (FS 3.3613)  
Безопасный  
HE18 818 71.074

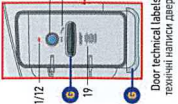

1/12  
19  
21722  
Decal technical labels /  
таблицы названий деталей

- 111 001 114 004
- 112 002 115 005
- 113 003 116 006

- 117 A 30-001
- 118 A 30-002
- 119 A 30-003
- 120 A 30-004
- 121 A 30-005
- 122 A 30-006

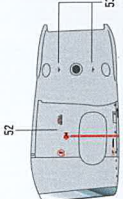

52  
Inner side of the right engine /  
внутренний бок правого двигателя

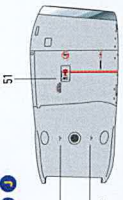

51  
Inner side of the left engine /  
внутренний бок левого двигателя

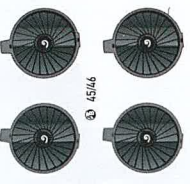

45/46

Turkish Air Force E-7T Peace Eagle,  
Konya Havalimani, Türkiye  
(NATO Air Force Base, Konya, Turkey)

from 78 to 88l

from 78 to 88r 2472aa



E-7T  
P.E.



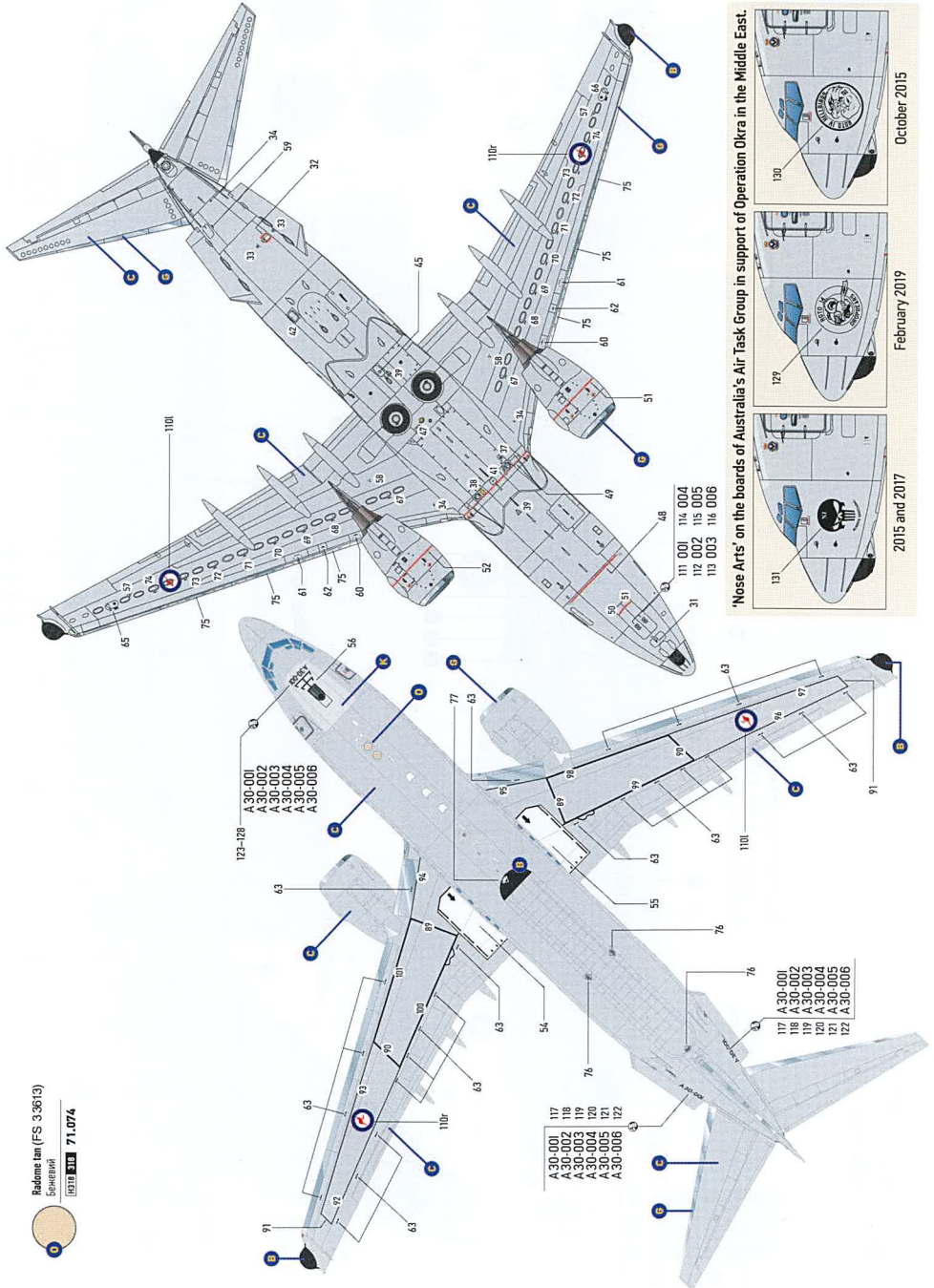

Радіомаяк (FS 33613)  
 Директор

71.074

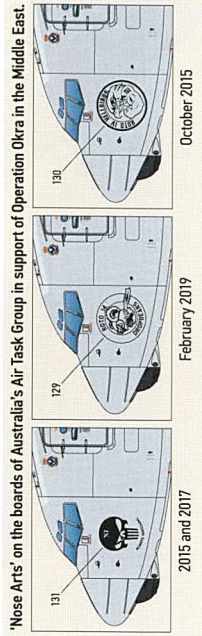

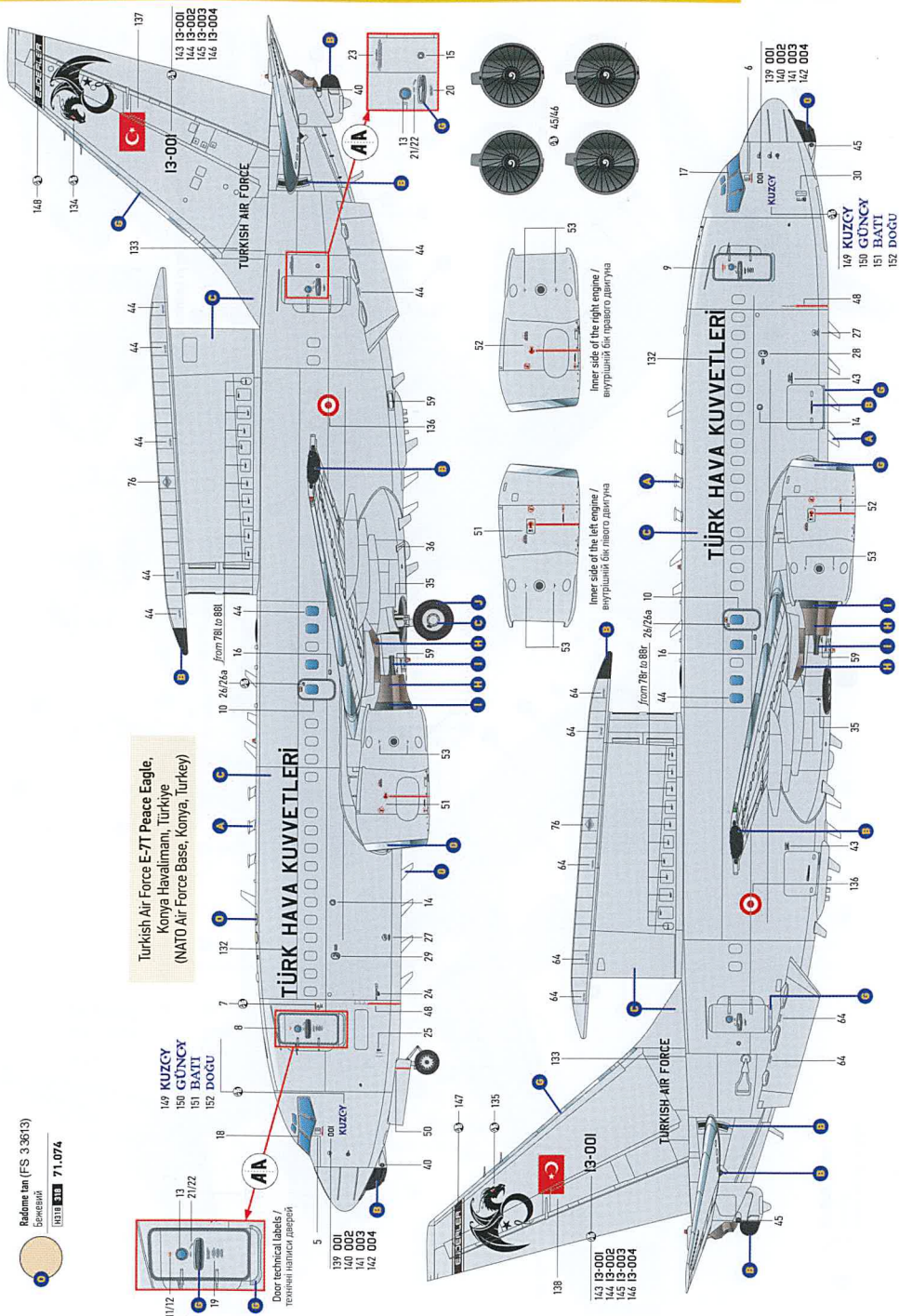

Turkish Air Force E-7T Peace Eagle,  
Konya Havalimani, Türkiye  
(NATO Air Force Base, Konya, Turkey)

149 KUZUY  
150 GÜNCY  
151 BATTI  
152 DOĞU

11/12  
13  
19  
21/22

Door technical labels /  
технічні картки дверей

138 001  
140 002  
141 003  
142 004

143 13-001  
144 13-002  
145 13-003  
146 13-004

139 001  
141 002  
141 003  
142 004

149 KUZUY  
150 GÜNCY  
151 BATTI  
152 DOĞU

138 001  
140 002  
141 003  
142 004

149 KUZUY  
150 GÜNCY  
151 BATTI  
152 DOĞU

149 KUZUY  
150 GÜNCY  
151 BATTI  
152 DOĞU

149 KUZUY  
150 GÜNCY  
151 BATTI  
152 DOĞU

149 KUZUY  
150 GÜNCY  
151 BATTI  
152 DOĞU

149 KUZUY  
150 GÜNCY  
151 BATTI  
152 DOĞU

149 KUZUY  
150 GÜNCY  
151 BATTI  
152 DOĞU

149 KUZUY  
150 GÜNCY  
151 BATTI  
152 DOĞU

149 KUZUY  
150 GÜNCY  
151 BATTI  
152 DOĞU

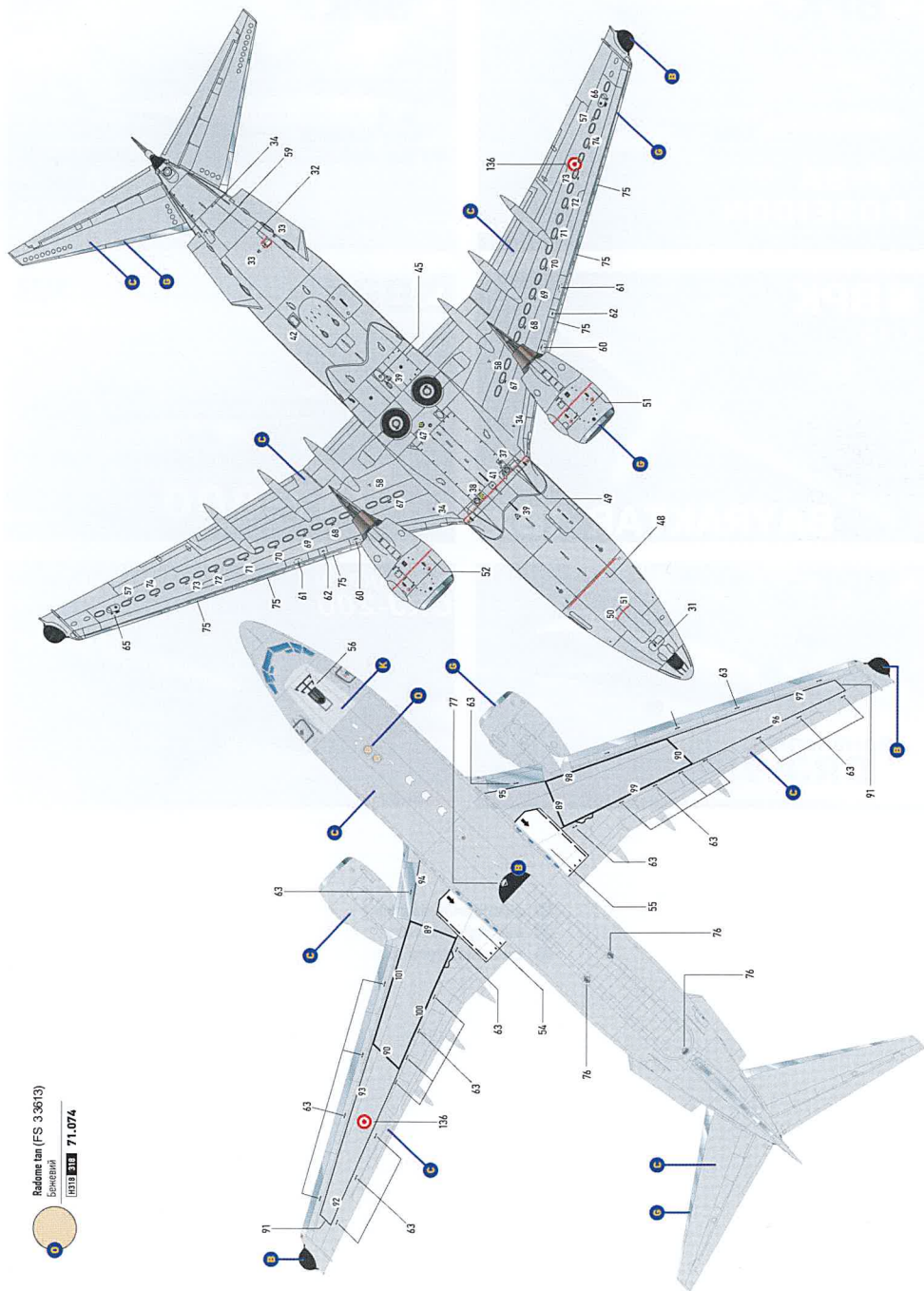

Радіомітант (FS 33613)

Сторінка

11 з 11 71.074



**BPK** \*BIG PLANE KITS

1/72 SCALE

**P-8A POSEIDON**

SCALE PLASTIC MODEL KIT

ITEM NO. 7222

Copyright 2015, Big Planes Kits, All Rights Reserved

**BPK** \*BIG PLANE KITS

1/72 SCALE

**C-40A CLIPPER/B**

SCALE PLASTIC MODEL KIT

ITEM NO. 7224

Copyright 2015, Big Planes Kits, All Rights Reserved

**BPK** \*BIG PLANE KITS

1/72 SCALE

**BAYRAKTAR TB2**

SCALE PLASTIC MODEL KIT

ITEM NO. 7220

Copyright 2015, Big Planes Kits, All Rights Reserved

**BPK** \*BIG PLANE KITS

1/72 SCALE

**BOEING 737-800**

SCALE PLASTIC MODEL KIT

ITEM NO. 7217

Copyright 2015, Big Planes Kits, All Rights Reserved

**BPK** \*BIG PLANE KITS

1/72 SCALE

**BOMBARDIER CRJ-700**

SCALE PLASTIC MODEL KIT

ITEM NO. 7216

Copyright 2015, Big Planes Kits, All Rights Reserved

**BOMBARDIER CRJ-200**

**BPK** \*BIG PLANE KITS

1/72 SCALE

**14402**

Copyright 2015, Big Planes Kits, All Rights Reserved

[f](https://www.facebook.com/bigplaneskits) www.fb.com/bigplaneskits  
[globe](http://www.bigplaneskits.com) www.bigplaneskits.com  
[@](mailto:bigplaneskits@gmail.com) bigplaneskits@gmail.com

TÜRK HAVA KUVVETLERİ  
 TÜRK HAVA KUVVETLERİ

TURKISH AIR FORCE  
 TURKISH AIR FORCE  
 ROYAL AUSTRALIAN AIR FORCE  
 ROYAL AUSTRALIAN AIR FORCE