

DORNIER Do 24-T



DORNIER Do 24-T

Prima del Conflitto Mondiale il Do 24 (progettato dalla fabbrica tedesca Dornier) veniva costruito, su licenza, negli stabilimenti olandesi dell'Aviolanda per conto del Governo olandese. Quando, nel '40, l'Olanda venne occupata, furono trovati 25 esemplari in vari stadi di approntamento, più altri tre completi. Poiché il Ministero dell'Aeronautica Tedesco era alla ricerca di un idrovolante idoneo al recupero degli equipaggi caduti in mare, i Do 24 olandesi furono sottoposti alle prove di valutazione, che ebbero pieno successo: il Do 24 aveva proprio le qualità giuste per un aereo da soccorso aeronavale: eccellente navigabilità anche con mare grosso, decollo corto, notevole capacità interna, elevata autonomia, buona velocità di crociera. Perciò nella primavera del '41 fu riattivata la produzione presso le fabbriche olandesi.

Per adattare l'aereo ai suoi compiti specifici furono apportate alcune varianti al modello originale: sul lato destro venne aperto un portello per facilitare le operazioni di recupero e l'interno della fusoliera fu dotata di sei cuccette e di attrezzature di pronto soccorso; venne migliorata la strumentazione radio e di volo e l'armamento difensivo portato a due MG 15 da 7,9 mm, nelle torrette anteriori e posteriori, più un cannone Hispano Suiza da 20 mm, (in seguito sostituito dal pari calibro tedesco MG 151) nella torretta dorsale. Gli aerei olandesi montavano il motore americano Wright Cyclone; esauritesi le scorte, i Tedeschi adottarono il motore radiale BMW Bramo. I Do 24, raggruppati in apposite unità ("Seenotstaffeln"), vennero impiegati su tutti i mari europei, e persino sull'Oceano Atlantico ed Artico. Un gruppo di stanza nel Mar Nero si distinse anche, dal febbraio al marzo del '43, nel rifornimento della testa di ponte di Kuban ed in seguito cooperò allo sgombero delle Isole Egee e dei Balcani. Nel Mediterraneo i Do 24 dipendevano dal Centro di Soccorso Aeronavale di Siracusa; altre basi si trovavano in Francia (a Brest, Cherbourg, Boulogne), in Norvegia, nel Baltico ed a Sylt. E' doveroso, inoltre, segnalare i Do 24 olandesi che combatterono nelle Indie Orientali contro i Giapponesi. Dodici aerei vennero forniti alla Spagna nel 1944: uno di essi è rimasto in servizio fino al 1970.

Caratteristiche tecniche: Apertura alare: m. 27,00; Lunghezza: m. 22,05; Peso a vuoto: Kg. 9400; Peso massimo: Kg. 16200; Velocità massima: Km./h. 330 a m. 2600; Autonomia massima a carico: Km. 4700; Quota di tangenza: m. 7500; Motori: 3 BMW Bramo 323 R-2, 9 cilindri radiali raffreddati ad aria, da 1000 HP al decollo; Armamento difensivo: 1 cannone da 20 mm. Hispano Suiza 404 oppure MG 151, 2 mitragliatrici MG 15 da 7,9 mm; Equipaggio: 6 uomini.

DORNIER Do 24-T

Before World War II the Do 24 was designed by the Dornier company and built under licence in Holland by order of the Dutch government.

When Holland was overrun by the German forces in 1940 they found 25 Do 24 flying boats at various stages of finishing, and 3 more finished.

The German Air Ministry was in search of a suitable flying boat to salvage sunk airplanes, and found in Holland an aircraft that met these specifications.

The Do 24 combined excellent navigational qualities even at heavy sea, ample space, sufficient cruising range and reasonable speed. In 1941 the production of the Do 24 was started again in the Netherlands. In order to adapt this plane for its special missions, various changes were made: on the right side installations were made to facilitate rescue operations.

In the fuselage beds and first aid equipment were installed. Radio and steering control were improved and as defence armament two 7.9 mm MGs 15 were mounted in the front and rear gunner positions. In the centre position a 20 mm Hispano Suiza cannon was mounted, but later replaced by a MG 151. Initially American "Wright" engines were fitted but later replaced by BMW engines.

The Do 24s were used in so-called sea-emergency-squads (Seenotstaffeln) and saw service on all European oceans including the Arctic.

In February/March 1943 one squadron was used to supply the Kuban bridge-head. Later Do 24s were saw service in the Greek and Balkan campaigns.

In the Mediterranean these aircraft had their support base in Siracusa. Other bases were in France (Brest, Cherbourg, Boulogne) in Norway, in the Baltic areas and on the island of Sylt. Do 24s were also used in the Indian Ocean against the Japanese. 1944 a squadron was supplied to Spain. One of these planes remained in service until 1970.

Technical data: Wing span: 27 m; Length: 22.05 m; Net weight: 9400 Kg; Max. weight: 16200 Kg; Max. speed: 330 Km/h at 2600 m altitude; Cruising range: 4700 Km fully loaded; Engines: 3 BMW Bramo 323 R-2, 9 cylinder, air-cooled, 1000 HP; Armament: 1 20 mm Hispano Suiza 404 gun or 1 MG 151 2 MG 15, 7.9 mm caliber; Crew: 6.

ATTENZIONE - Consigli utili!

Prima di iniziare il montaggio, studiare attentamente il disegno. Staccare con molta cura i pezzi dalle stampe, usando un taglia-balsa oppure un paio di forbici e togliere con una piccola lima o con carta vetro fine eventuali sbavature. Mai staccare i pezzi con le mani. Montarli seguendo l'ordine della numerazione delle tavole. Eliminare dalla stampata il numero del pezzo appena montato, facendogli sopra una croce. Le frecce nere indicano i pezzi da incollare, le frecce bianche indicano i pezzi da montare senza colla. Usare solo colla per polistirolo. ▲●■ i contrassegni ai lati dei numeri indicano la stampata ove si trova il pezzo da montare.

ATTENTION - Useful advice!

Study the instructions carefully prior to assembly. Remove parts from frame with a sharp knife or a pair of scissors and trim away excess plastic. Do not pull off parts. Assemble the parts in numerical sequence. Use plastic cement ONLY and use cement sparingly to avoid damaging the model. Black arrows indicate parts to be glued together. White arrows indicate that parts must be assembled WITHOUT using cement. ▲●■ These marks indicate on which frame the parts will be found. Paint small parts before detaching them from frame. Remove paint where parts are to be cemented.

ACHTUNG - Ein nützlicher Rat!

Vor der Montage die Zeichnung aufmerksam studieren. Die einzelnen Montageteile mit einem Messer oder einer Schere vom Spritzling sorgfältig entfernen. Eventuelle Grate werden mit einer Klinge oder feinem Schmirgelpapier beseitigt. Keinesfalls die Montageteile mit den Händen entfernen. Bei der Montage der Tafelnumerierung folgen. Die Nummer der schon montierten Teile auf dem Spritzling ankreuzen. Die schwarzen Pfeile zeigen die zu klebenden Teile während die weissen Pfeile die ohne Leim zu montierenden Teile anzeigen. Bitte nur Plastikklebstoff verwenden. ▲●■ Die Markierung neben den Nummern zeigt, auf welchem Spritzling der zu montierende Teil zu finden ist.

ATTENTION - Conseils utiles!

Avant de commencer le montage, étudier attentivement le dessin. Détacher avec beaucoup de soin les morceaux des moules en utilisant un massicot ou bien un pair de ciseaux et couper avec une petite lame ou avec de papier de verre fin ébarbagés éventuels. Jamais détacher les morceaux avec les mains. Monter les en suivant l'ordre de la numération des tables. Éliminer de la moule le numéro de la pièce qui vient d'être montée, en le bifant avec une croix. Les flèches noires indiquent les pièces à coller, les flèches blanches indiquent les pièces à monter sans colle. Employer seulement de la colle pour polystyrol. ▲●■ Les signes aux côtés des numéros indiquent la moule où se trouve la pièces à monter.

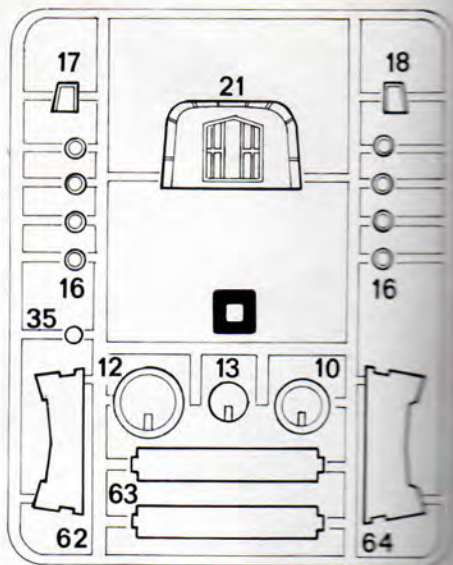

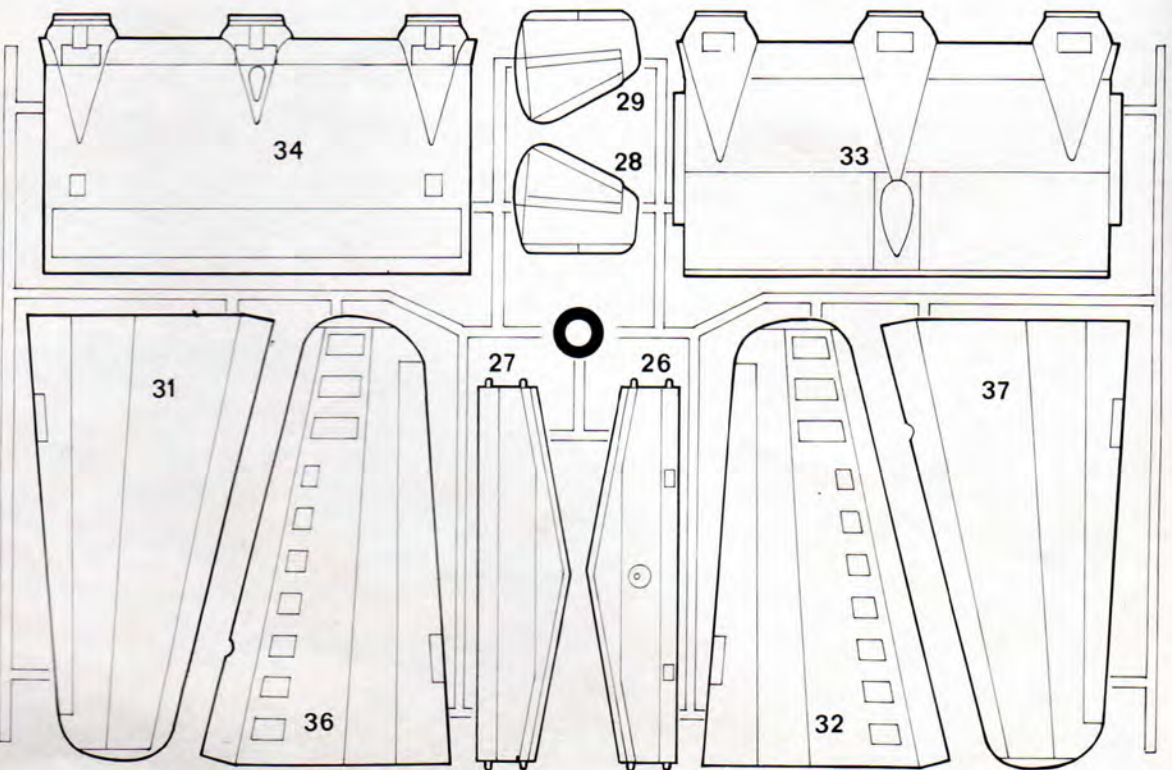
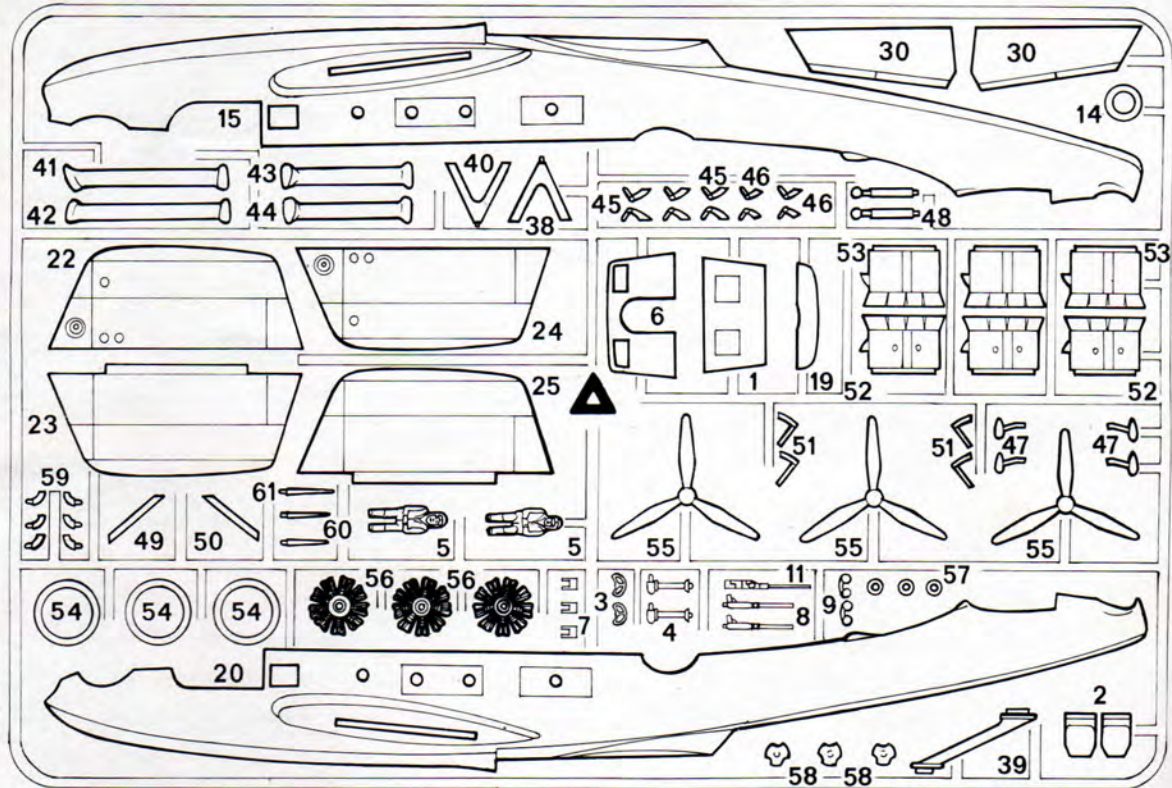

Istruzioni per la colorazione

Paint instructions

a NERO OPACO
FLAT BLACK
MATTSCHWARZ
NOIR OPAQUE

b GRIGIO VERDE RLM 02
GREY - GREEN RLM 02
GRAU - GRUEN RLM 02
GRIS - VERT RLM 02

c ARGENTO BRUNITO
1/2 NERO 1/2 ARGENTO
AIRFRAME SILVER
1/2 BLACK 1/2 SILVER
FLUGWERK SILVER
1/2 SCHWARZ 1/2 SILBER
ARGENT
1/2 NOIR 1/2 ARGENT

d NERO METALLO
3/4 NERO 1/4 ARGENT
GRUN METAL
3/4 BLACK 1/4 SILVER
METALLSCHWARZ
3/4 SCHWARZ 1/4 SILBER
NOIR METALLISE
3/4 NOIR 1/4 ARGENT

f ROSSO-BRUNO
1/2 NERO 1/2 ROSSO
EXHAUST RED
1/2 BLACK 1/2 RED
ROTBRAUN
1/2 SCHWARZ 1/2 ROT
ROUGE-BRUN
1/2 NOIR 1/2 ROUGE

g MARRONE
BROWN
BRAUN
BRUN

h MARRONE SCURO
DARK BROWN
DUNKELBRAUN
BRUN SOMBRE

1 1-14

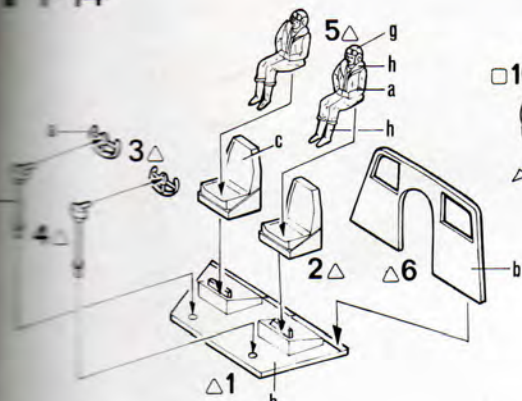

MG 15 7.9 mm

MG 151 20 mm

MG 15 7.9 mm

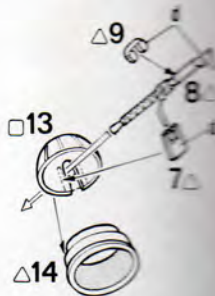
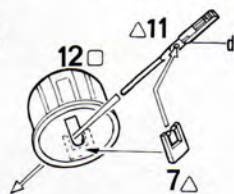
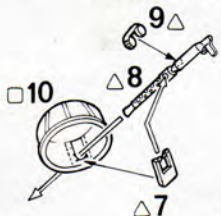

2 15-20

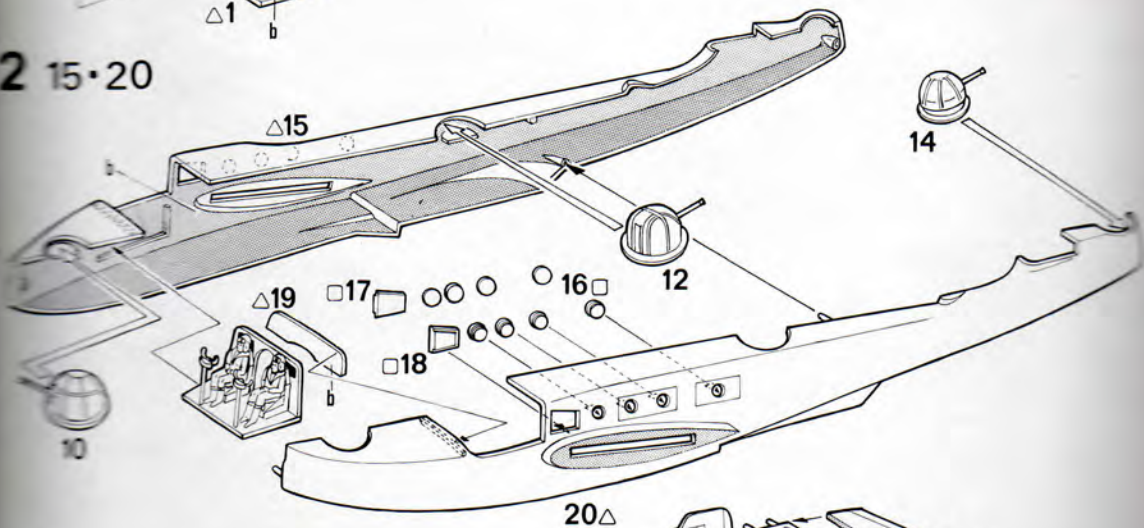

3 21-30

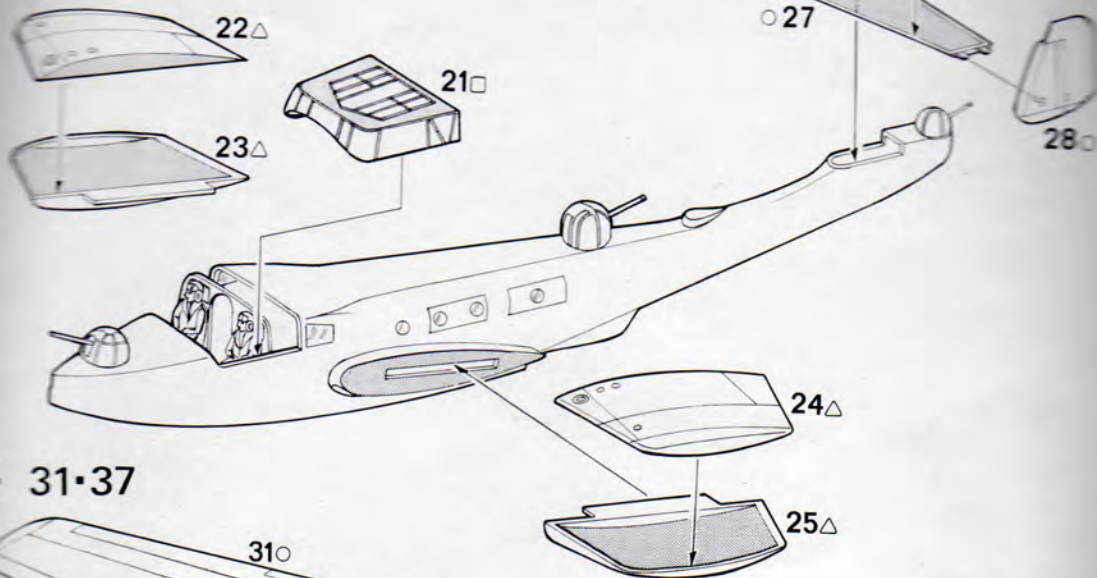

4 31-37

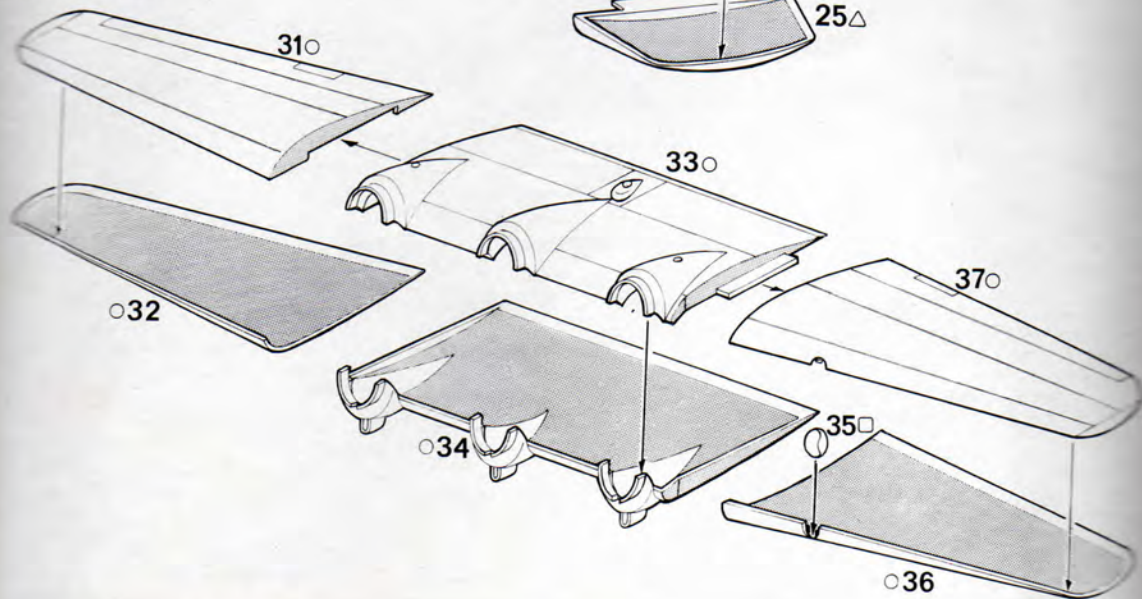

5 38-48

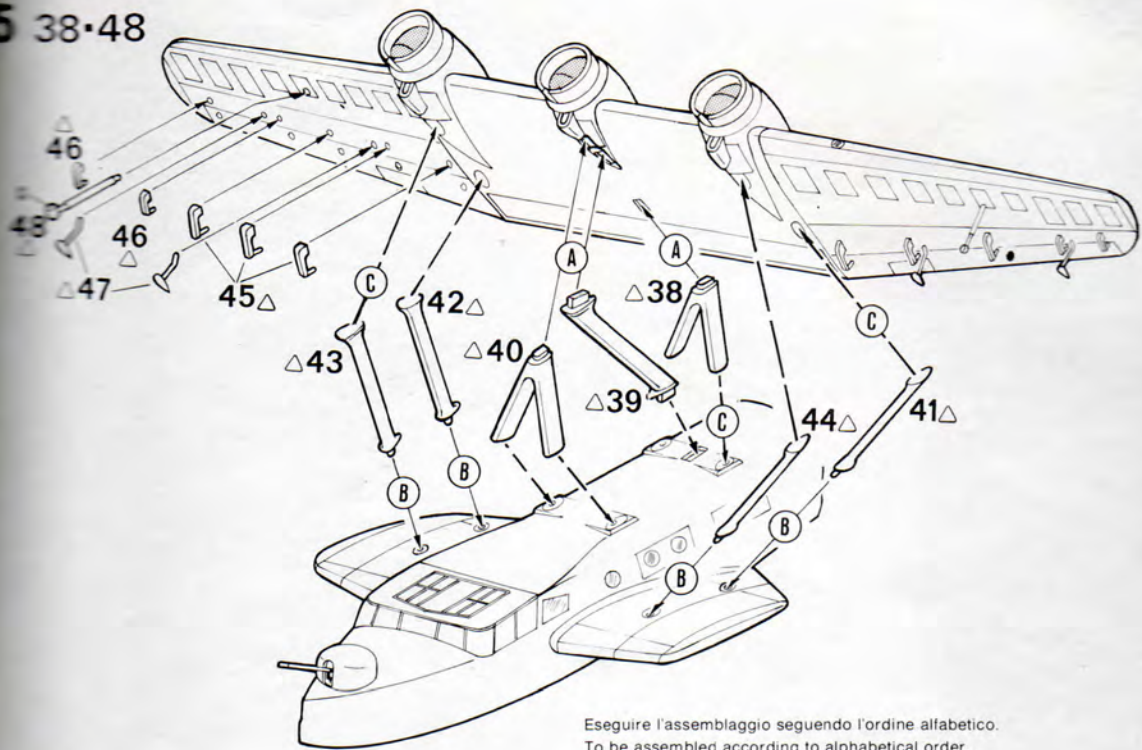

Eeguire l'assemblaggio seguendo l'ordine alfabetico.
 To be assembled according to alphabetical order.
 Montage nach alphabetischer Reihenfolge durchführen.
 Montage en ordre alphabétique.

6 49-51

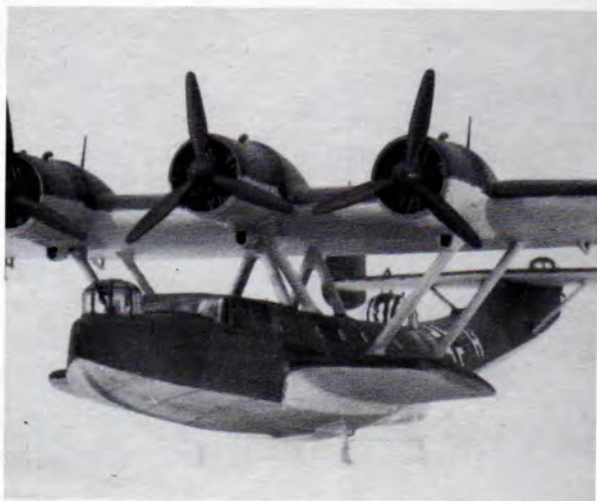
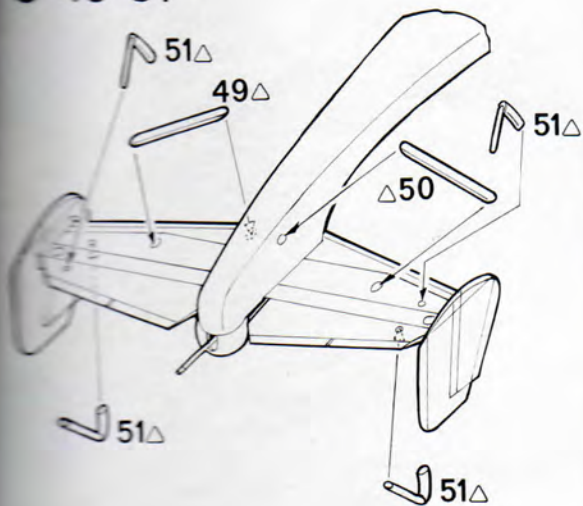

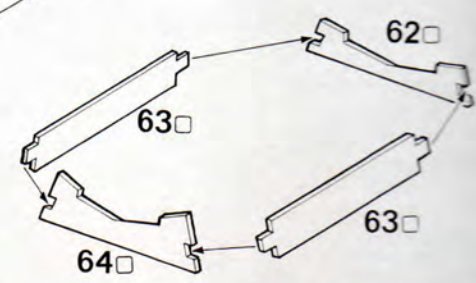
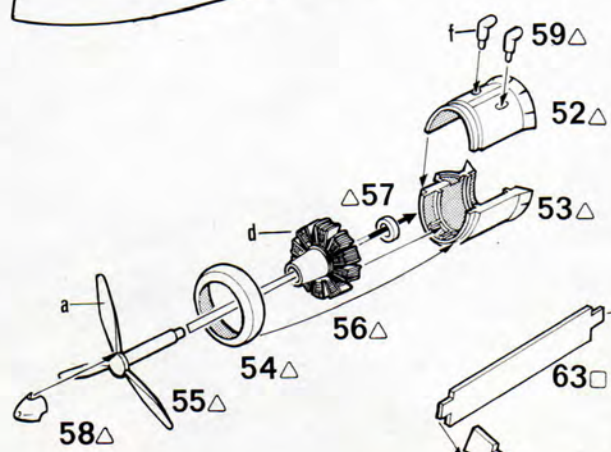
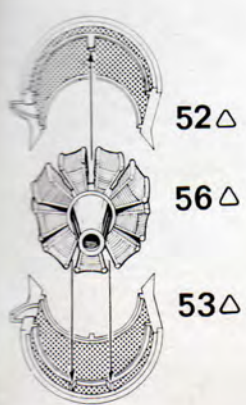
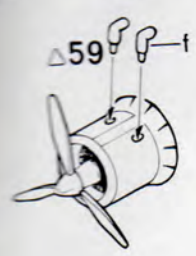
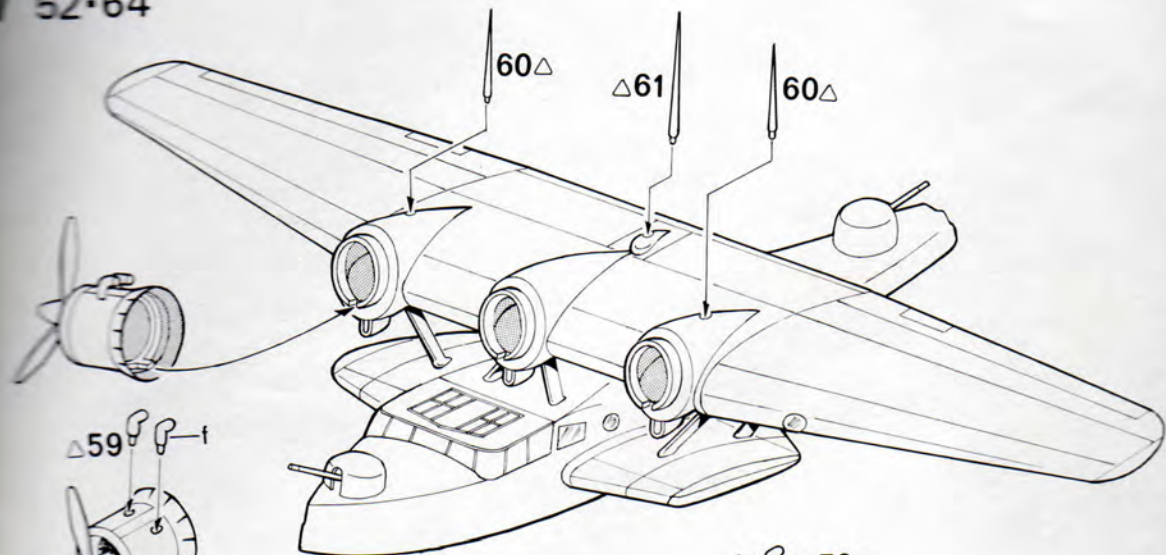



Istruzioni per l'applicazione delle decalcomanie: Ritagliare le decalcomanie occorrenti dal foglio, immergerle in un bicchiere d'acqua pulita per circa 1/2 minuto, metterle in posizione sul modello e farle scivolare sulla carta; per una migliore aderenza comprimerle con una pezzuola pulita.

Directions for applying the decals: Cut the required decals out of the sheet; dip them into a glass of clean water for about 1/2 minute; position the decals on the kit, letting them slide from the paper. For better adhesion, press them by means of a clean rag.

ala destra
right wing
rechterflügel
aile droite

Superf. inferiore ala sinistra
Under surfaces left wing
Unteroberfläche linkerflügel
Surface inferieure aile gauche

SCHEMI DIVERS
PAINT
BEMALUNGS
SCHEMAS DIFFERENTS

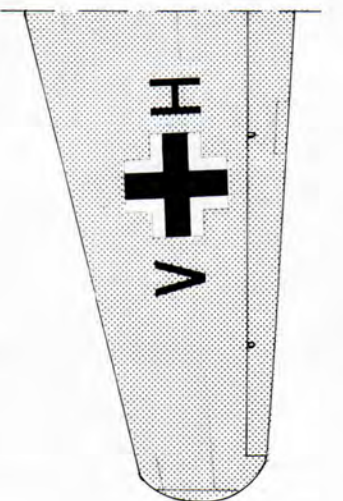
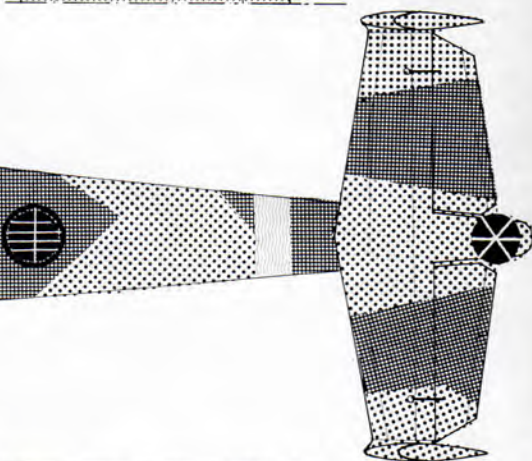
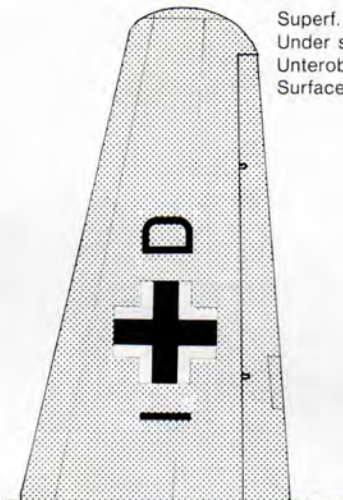
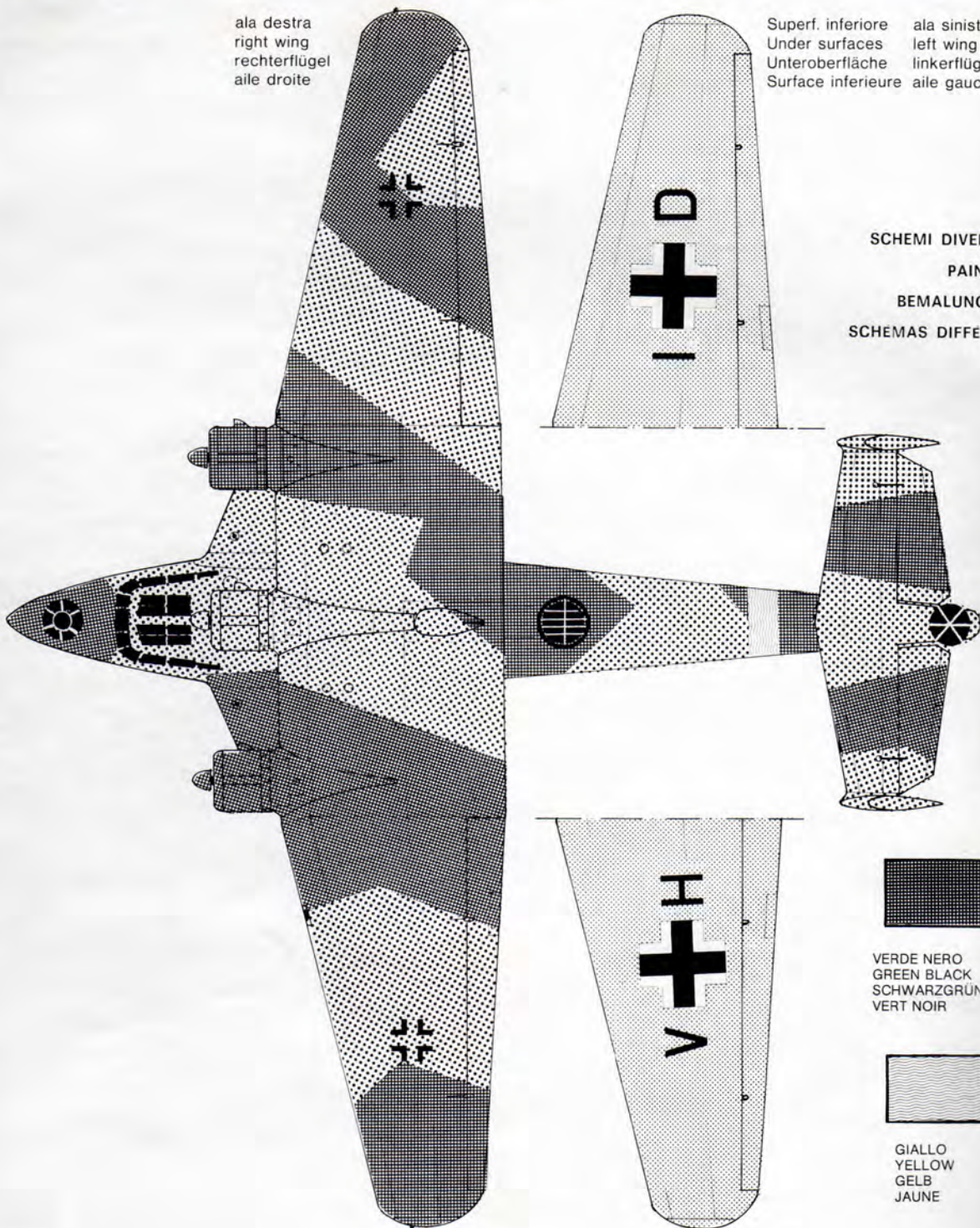

VERDE NERO
GREEN BLACK
SCHWARZGRÜN
VERT NOIR



GIALLO
YELLOW
GELB
JAUNE

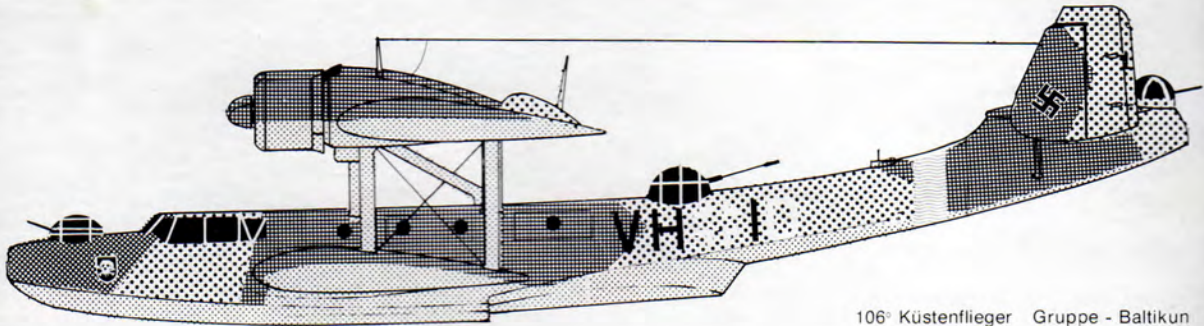

106° Küstenflieger Gruppe - Baltikum

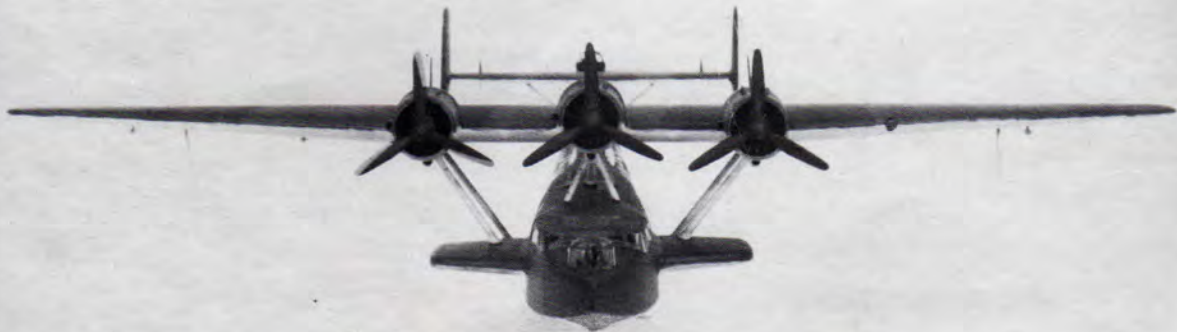

bergerle
re dalla
of clean
a better

Montageanweisungen der Abziehbilder: Die benoetigten Abziehbilder vom Blatt abschneiden; sie in ein Glas reines Wasser fuer etwa 1-2 Minute eintauchen; sie auf das Modell positionieren und dann vom Papierbogen abnehmen; fuer eine bessere Adhaesion, die Abziehbilder mittels eines reinen Tuchs druecken.

Instruction: pour l'application des decalcomanies. Couper les decalcomanies choisies et les plonger environ trente secondes dans un peu d'eau propre. Les placer sur le modele en les faisant glisser de leur feuille et presser avec un morceau de chiffon pour eliminer les bulles d'air.

ala destra
right wing
rechterflügel
aile droite

Superf. inferiore
Under surfaces
Unteroberfläche
Surface inferieure

ala sinistra
left wing
linkerflügel
aile gauche

DI COLORAZIONE
SCHEMES
MÖGLICHKEITEN
S DE COLORATION

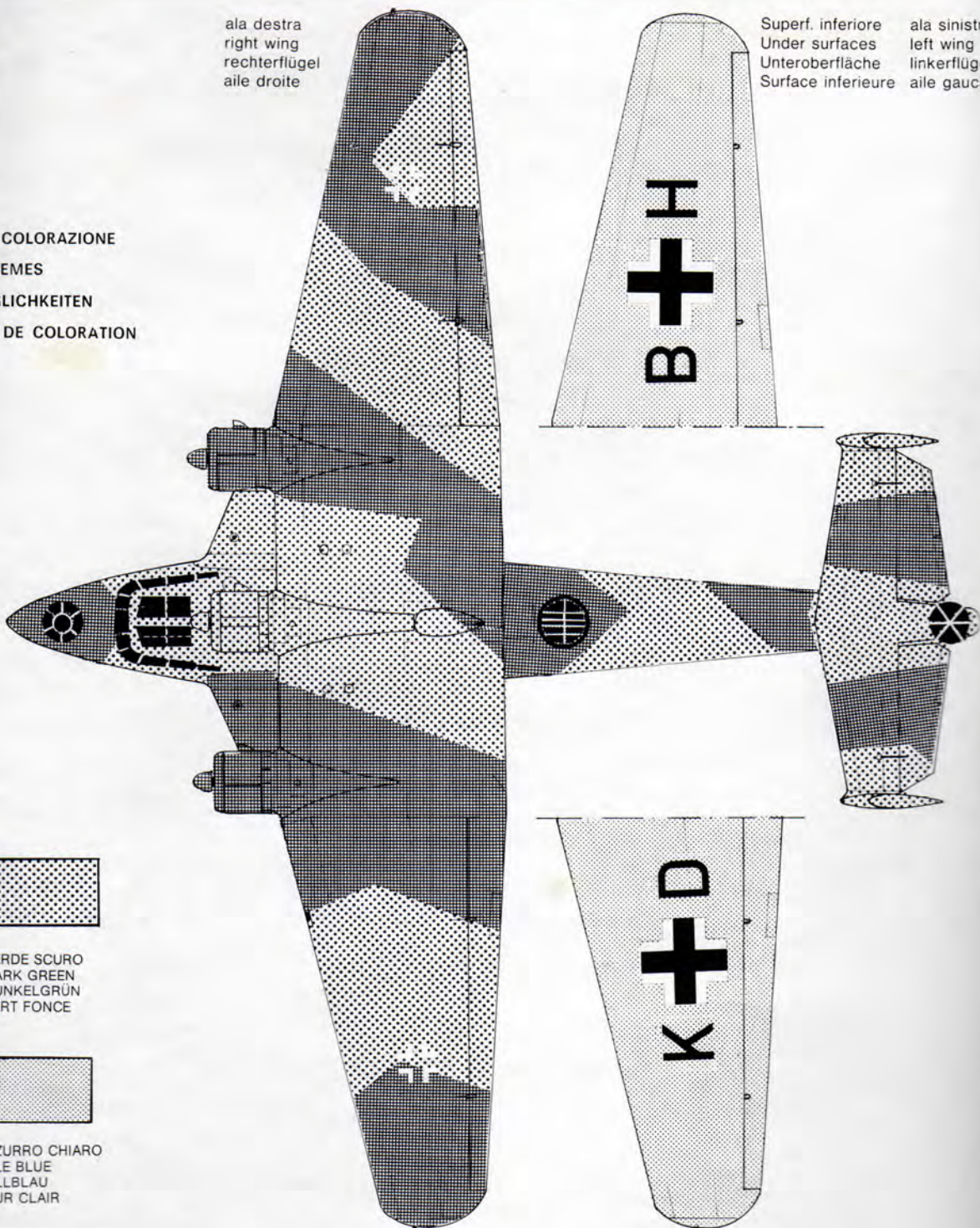

VERDE SCURO
DARK GREEN
DUNKELGRÜN
VERT FONCE

AZZURRO CHIARO
PALE BLUE
HELLBLAU
AZUR CLAIR

SCHEMES
MÖGLICHKEITEN
SCHEMES DE COLORATION

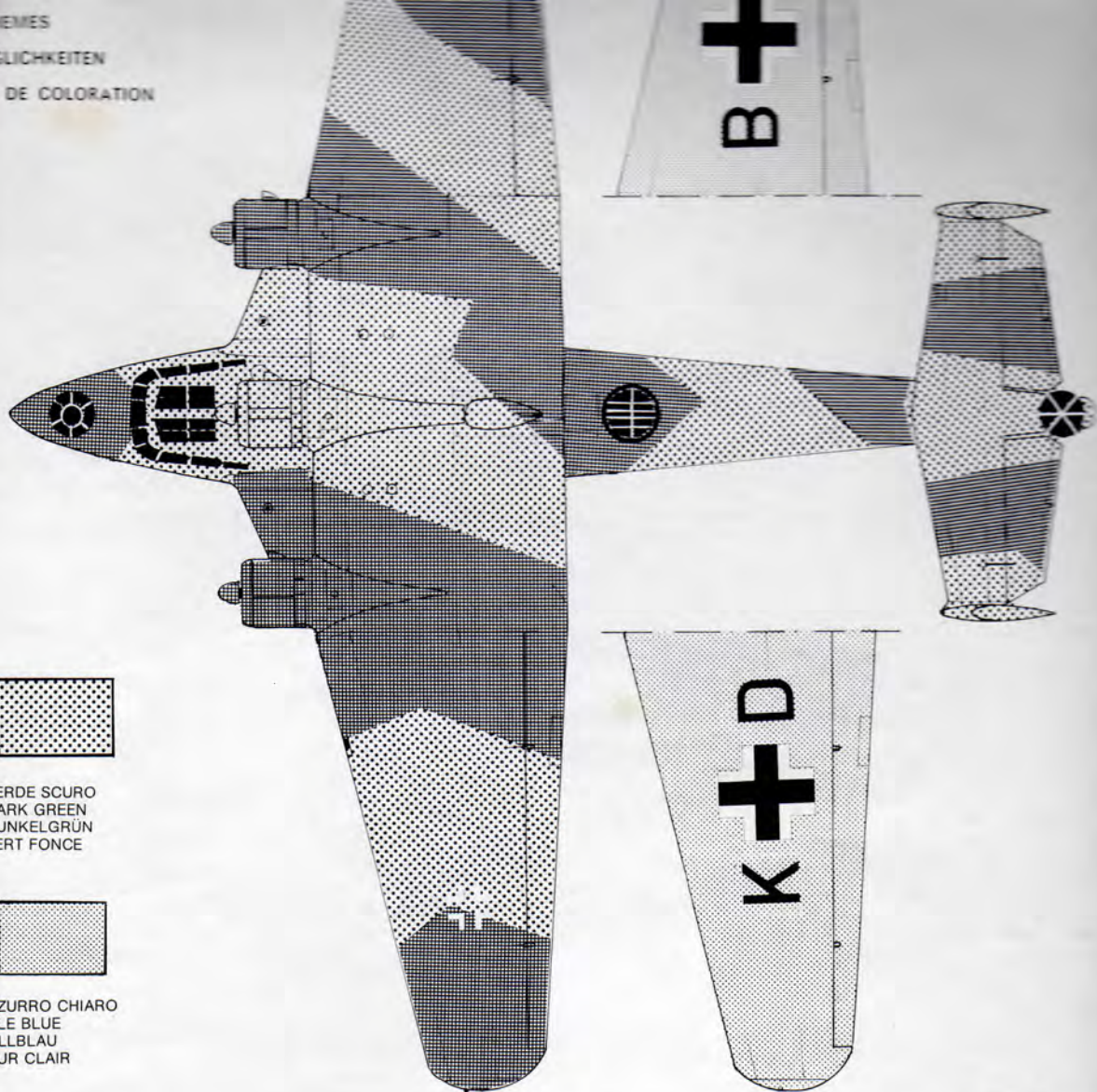

VERDE SCURO
DARK GREEN
DUNKELGRÜN
VERT FONCE



AZZURRO CHIARO
PALE BLUE
HELLBLAU
AZUR CLAIR

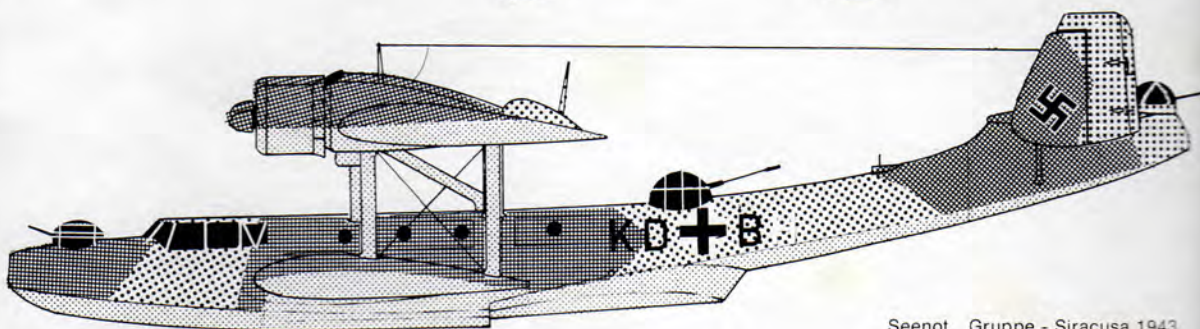

Seenot Gruppe - Siracusa 1943

DORNIER Do 24-T

Le Do 24 sortit des Usines Dornier avant la Seconde Guerre Mondiale. L'Hollande le construisit sous licence. Lorsque les troupes allemandes envahirent les Pays-Bas en 1940, elles s'emparèrent d'un très grand nombre d'hydravions Do 24.

La Luftwaffe, qui cherchait un hydravion approprié pour le sauvetage de ses avions perdus en mer, trouva en Hollande des avions prêts à l'emploi, les Do 24.

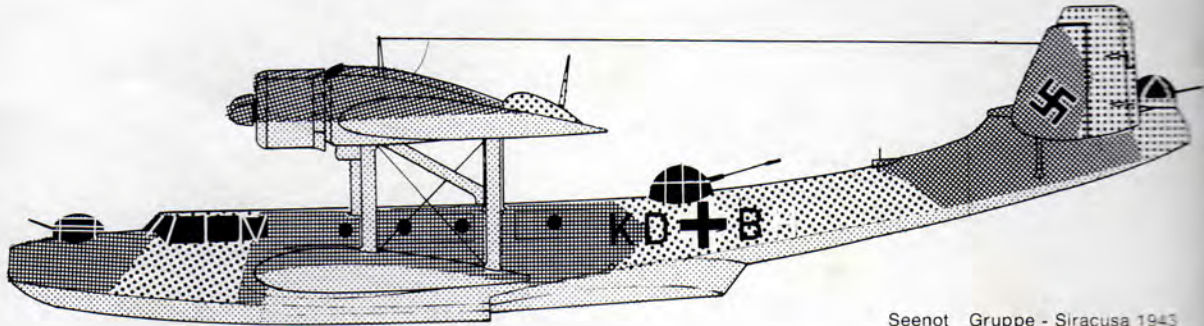

Seenot Gruppe - Siracusa 1943

DORNIER Do 24-T

Le Do 24 sortit des Usines Dornier avant la Seconde Guerre Mondiale. L'Hollande le construisit sous licence. Lorsque les troupes allemandes envahirent les Pays-Bas en 1940, elles s'emparèrent d'un très grand nombre d'hydravions Do 24.

La Luftwaffe, qui cherchait un hydravion approprié pour le sauvetage de ses avions perdus en mer, trouva en Hollande des avions prêts à l'emploi, les Do 24.

Il possédait d'excellentes qualités de navigation par grosse mer, un vaste fuselage, ainsi qu'un rayon d'action d'une vitesse suffisants. Des modifications y furent apportées pour l'adapter à ses nouvelles missions. Sur le côté droit de l'appareil des aménagements furent installés pour faciliter les opérations de sauvetage. On installa dans le fuselage des lits et des équipements de premiers secours. Les appareils de radio et de navigation furent améliorés, et les verrières avant et arrière furent équipées chacune d'une mitrailleuse MG 15 de 7,9 mm. La verrière intermédiaire reçut, elle, un canon Hispano-Suiza de 20 mm, qui fut changé par la suite contre un MG 151. Les moteurs Whright, d'origine américaine, furent remplacés peu à peu par des BMW. Organisés en escadrilles spéciales de sauvetage (les "Seenotstraffeln"), les Do 24 ont opéré sur toutes les mers européennes, y compris sur les mers polaires.

Par la suite, le Do 24 fut utilisé dans les Balkans et en mer Egée. La base des hydravions de secours en Méditerranée se trouvait à Syracuse. D'autres bases étaient réparties en France (Brest, Cherbourg, Boulogne), en Norvège, en Mer Baltique et en Syll. Des Do 24 servirent également dans l'Océan Indien contre les Japonais. Une escadrille de Do 24 fut livrée à l'Espagne, et un des appareils servit jusqu'en 1970.

Spécifications techniques: Envergure: 27 m; Longueur: 22,05 m; Poids à vide: 9400 Kg; Poids en charge max: 16200 Kg; Vitesse maximale: 330 Km/h à 2600 m d'altitude; Rayon d'action: 4700 Km à pleine charge; Moteurs: 3 BMW Bramo 323 R-2 9 cylindres, refroidis par air, de 1000 CV; Armement: 1 canon 20 mm Hispano-Suiza 404 ou un MG 151 2 mitrailleuses MG 15 de 7,9 mm; Equipage: 6 hommes.