



EF-111 RAVEN

1/72 SCALE MASSTAB 1:72 ESCALA 1/72

SCHAAL 1:72 1/72 ECHELLE SKALA 1/72 SCALA 1/72

KIT 5435

MONOGRAM MODELS, INC. Morton Grove, Ill. Copyright © 1984 All rights reserved. Made in U.S.A. 5435-0201

The EF-111 Raven is a tactical jamming aircraft designed to overcome the extremely high air defense threats encountered in modern warfare. Closely resembling its predecessor, the F-111A fighter, the Raven combines the agility of a fighter, the payload of a bomber, and the electronic countermeasures (ECM) equipment of a jammer.

The EF-111 was developed for the electronic warfare role by Grumman Aerospace Corporation. It is equipped with an ALQ-99E jamming system which has the ability to pick up, identify, and neutralize hostile radars over a wide range of frequencies. Distinguished by its fin cap radome and canoe-shaped

weapons bay radome, it carries various antennae added to accommodate new avionics.

The Raven is operated by a crew of two, a pilot and an electronic warfare officer. The EWO operates the complex electronic systems of the aircraft. Power is provided by two Pratt & Whitney TF30-P-3 turbofan engines. Maximum speed is over 1400 miles per hour, and the aircraft's combat ceiling is in excess of 44,000 feet.

Your Monogram model of the EF-111 can be completed in the latest low-visibility gray camouflage scheme. It is a highly-detailed kit of an aircraft that will play an indispensable part in aerial warfare.

READ THIS BEFORE YOU BEGIN

- Study the assembly drawings.
- Each plastic part is identified by a number.
- Check the fit of each piece before cementing in place.
- Do not use too much cement to join parts.
- Use only cement for polystyrene plastic.
- Model may be painted to match photos on box.
- Allow paint to dry thoroughly before handling parts.
- Scrape paint from areas to be cemented.
- For better paint and decal adhesion, wash the plastic parts in a mild detergent solution. Rinse and let air dry.

ALLGEMEINE HINWEISE

- Die Anordnung der Bauteile ist aus den Zeichnungen der Anleitung ersichtlich.
- Jedes Plastikteil ist durch eine Nummer gekennzeichnet.
- Die Teile vor dem Verkleben ungeleimt zusammenhalten, um ihren Passitz zu prüfen.
- Klebstoff nicht zu dick auftragen.
- Nur Modellbaukleber für Polystyrol verwenden.
- Man kann das Modell nach den Fotos auf der Schachtel anstreichen.
- Bemalte Teile vor der Weiterverwendung gut trocknen lassen.
- Die Farbe muss von allen späteren Klebestellen abgeschabt werden.
- Damit die Farbe und die Abziehbilder besser kleben, sind die Plastikteile in einer milden Seifenlauge zu waschen. Dann abspülen und an der Luft trocknen lassen.

LEA ESTO ANTES DE EMPEZAR

- Estudie los dibujos de ensamblaje.
- Cada pieza de plástico se identifica por un número.
- Verifique que cada pieza encaje bien antes de pegar en posición.
- No use demasiado pegamento para unir las piezas.
- Use únicamente pegamento para plástico de poliestireno.
- El modelo puede pintarse de acuerdo con las fotografías de la caja.
- Permita que se seque la pintura completamente antes de tocar las piezas.
- Raspe la pintura de las superficies que serán pegadas.
- Para una mejor fijación de la pintura y de las calcomanías, lávese las piezas plásticas en una solución de detergente suave. Enjuáguese y déjense secar al aire.

LEES DIT ALVORENS TE BEGINNEN

- Bestudeer de bouwtekening.
- Elk plastic onderdeel is genummerd.
- Controleer de passing van elk deel vóór het lijmen.
- Gebruik niet te veel lijm.
- Alleen lijm voor polystyreen plastic gebruiken.

- Men kan model verven zoals aangeduid op de doos.
- Laat de verf van de te verwerken delen steeds goed drogen.
- Verwijder de verf van te lijmen oppervlakken.
- Zodat de verf en etiketten beter zullen plakken, was de plasticke delen in een milde seep oplossing. Spoel en laat in de openlucht opdrogen.

LISEZ CE QUI SUIT AVANT DE COMMENCER LE MONTAGE

- Etudier les schémas d'assemblage.
- Chaque pièce plastique porte un numéro d'identification.
- Contrôler que chaque pièce soit bien conforme avant de la coller à sa place.
- N'utilisez pas trop de colle pour réunir les pièces.
- Utilisez uniquement une colle spéciale pour polystyrène.
- Le modèle peut être peint conformément aux photos sur la boîte.
- Laissez sécher la peinture complètement, avant de manipuler les pièces.
- Grattez la peinture sur les surfaces devant être collées.
- Pour assurer la meilleure adhesion possible de la peinture et des décalcomanies, lavez les pièces de plastique avec une légère solution savonneuse. Rincer et laisser sécher à l'air.

LAS DET HAR INNAN DU BORJAR BYGGA

- Studera monteringskisserna.
- Alla plastdelar har identifikationsnummer.
- Kolla noga att delarna passar före limningen.
- Stryk inte för mycket lim på delarna.
- Använd endast lim för polystyren-plast.
- Modellen kan malas enligt fotona på kantonen.
- Lat färgen torka ordentligt före limningen.
- Skrapa bort färgen på de ytor som ska limmas.
- För bättre vidhäftning av färg och dekalmarken rengör plastdelarna i en mild tvättmedelslösning. Skölj och lat lufttorka.

DA LEGGERE PRIMA DI INIZIARE

- Studia le illustrazioni.
- Ogni pezzo è identificato da un numero.
- Controlla l'incastro di ogni pezzo prima di incollarlo.
- Non usare troppa colla per unire i pezzi.
- Adopera solamente colla per materie plastiche.
- Il modello si può dipingere seguendo le fotografie sulla scatola.
- Aspetta che la vernice sia completamente asciutta prima di maneggiare le parti.
- Asporta la vernice dai punti dove applicherai la colla.
- Per una migliore aderenza di vernice e decalcomanie, lavare le parti in plastica in soluzione detergente non abrasiva. Risciacquare e lasciar asciugare all'aria.



REMOVE AND THROW AWAY
ENTFERNEN (ABFALL)
QUITE Y TIRE
VERWIJDEREN EN WEGGOEDEN
À RETIRER ET JETER
AVLAGSNAS OCH MAKULERAS
RIMOUVI ED ELIMINA



DO NOT CEMENT
NICHT KLEBEN
NO USE PEGAMENTO
NIET LIJMEN
NE PAS COLLER
LIMMAS INTE
NON INCOLLARE



DECAL (DIP IN WATER)
ABZIEHBILD
DECALCOMANIA (MOJE CON AGUA)
TRANSFERS (IN WATER DOPEN)
DECALCOMANIE (À PLONGER DANS L'EAU)
DEKAL (DOPPAS I VATTEN)
DECALCOMANIA (IMMERGI IN ACQUA)

The numerical color code listed below indicates the correct Monogram-Humbrol color selections that you will need to detail your kit. These paints are specially formulated for application to plastic surfaces and are available at your favorite hobby retailer.

A	128 COMPASS GHOST GRAY	GRAU	GRIS	GRIS	GRIS	GRÄ	GRIGIO
B	147 LIGHT GRAY	HELLGRAU	GRIS CLARO	LICHT GRIJS	GRIS CLAIR	LJUSGRÄ	GRIGIO CHIARO
C	33 FLAT BLACK	SCHWARZ	NEGRO	ZWART	NOIR	SVART	NERO
D	34 FLAT WHITE	WEISS	BLANCO	WIT	BLANC	VIT	BIANCO
E	53 GUNMETAL	METALLIC	METALICO	METALLIEK	METALLIC	METALLGLANS	METALLICO
F	156 OLIVE DRAB	OLIVGRÜN	ACEITUNADO	OLIJFGROEN	VERT OLIVE	OLIVBRUN	VERDE OLIVA SCURO
G	19 BRIGHT RED	ROT	ROJO	ROOD	ROUGE	RÖD	ROSSO
H	11 SILVER FOX	SILBERN	PLATA	ZILVER	ARGENT	SILVERFARG	ARGENTO

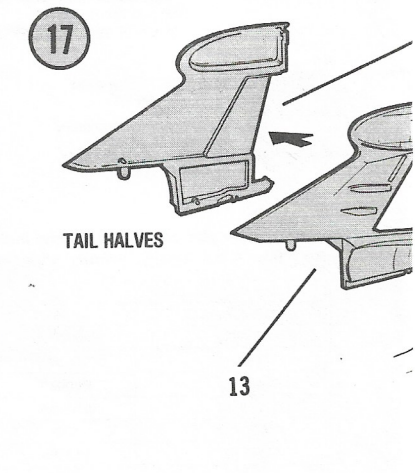
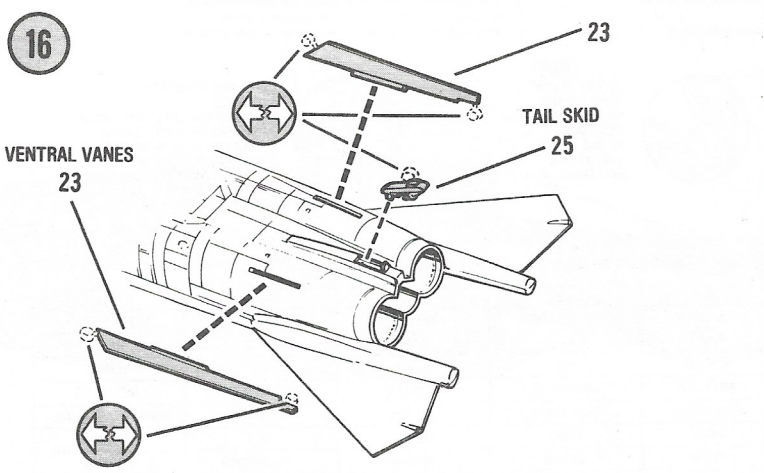
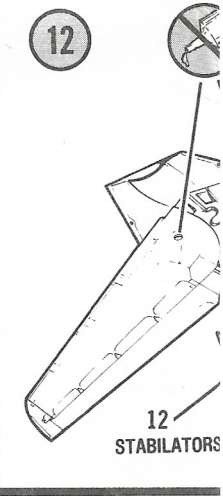
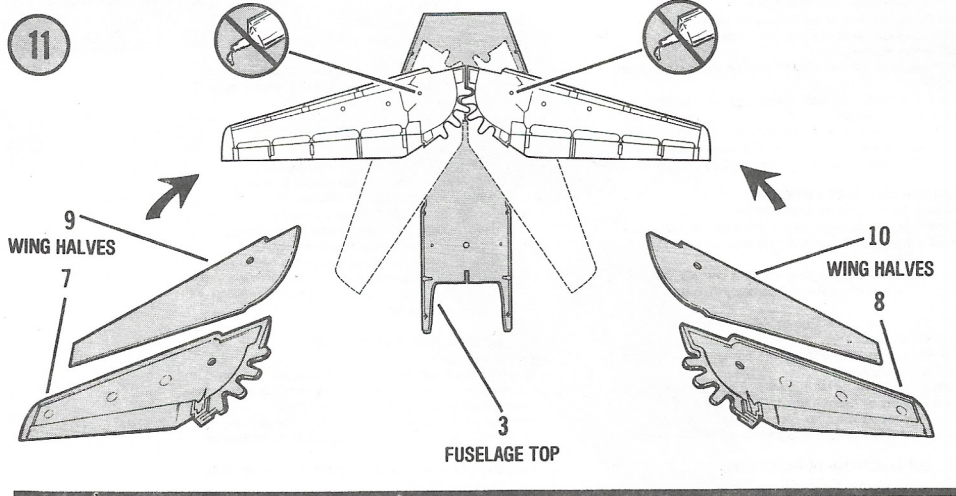
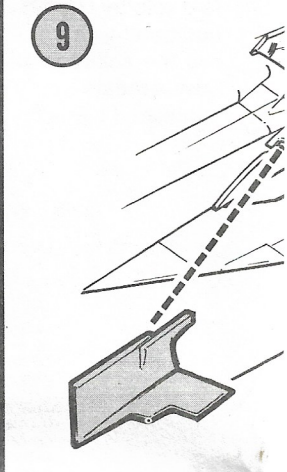
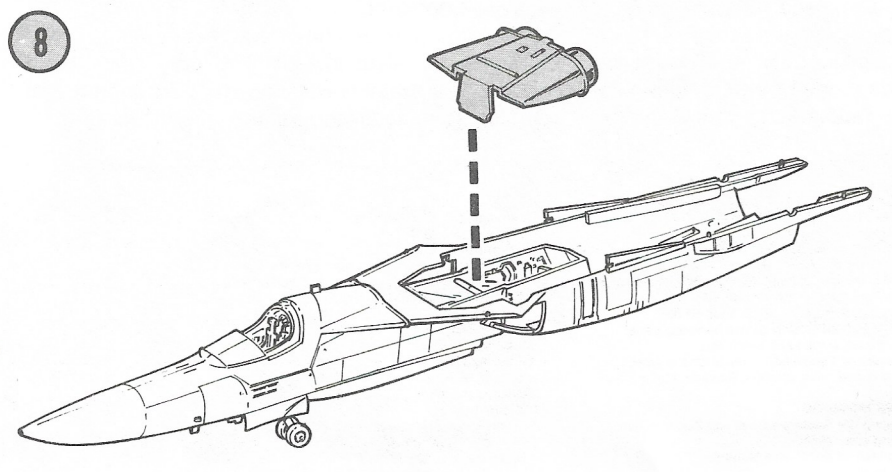
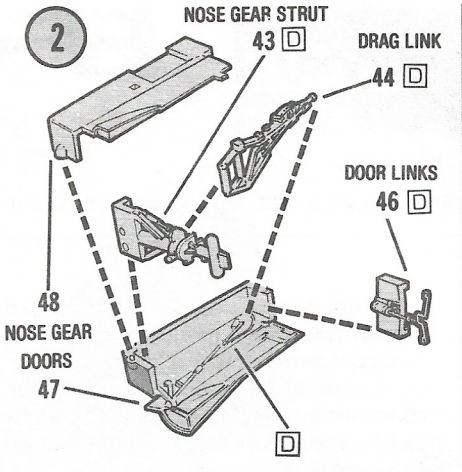
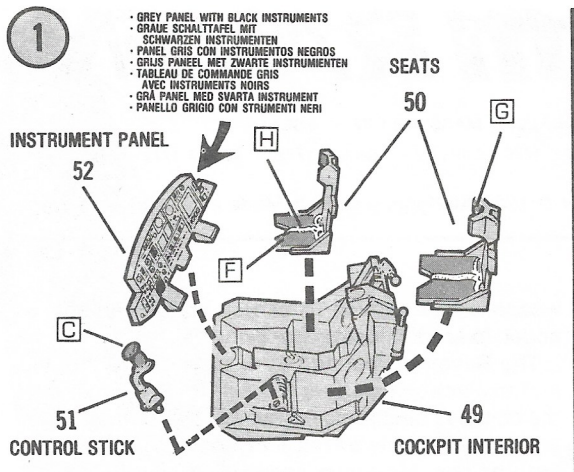

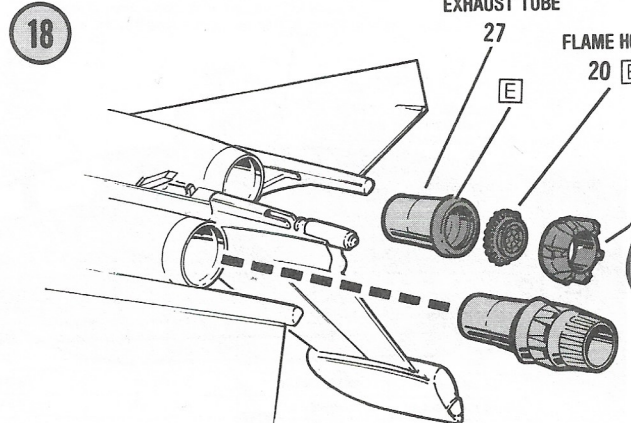
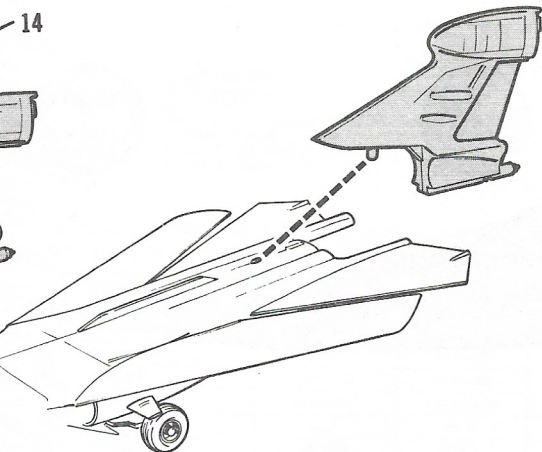
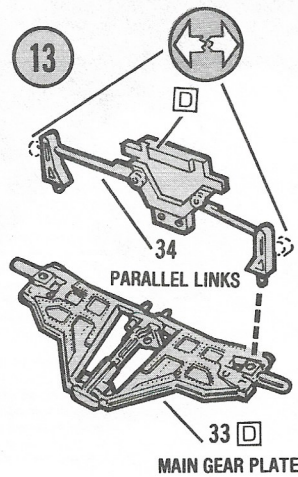
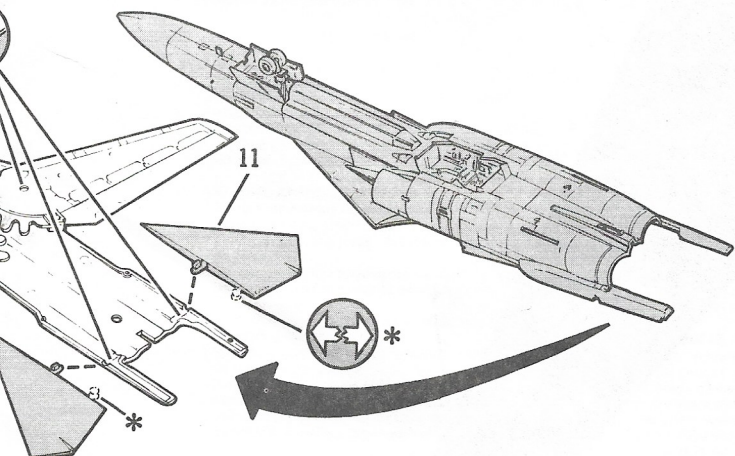
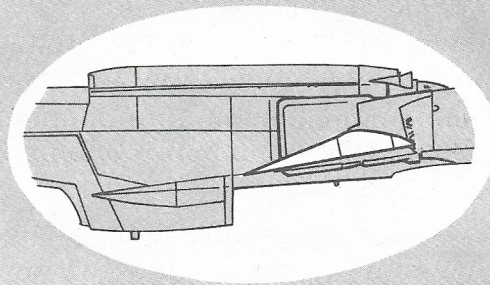
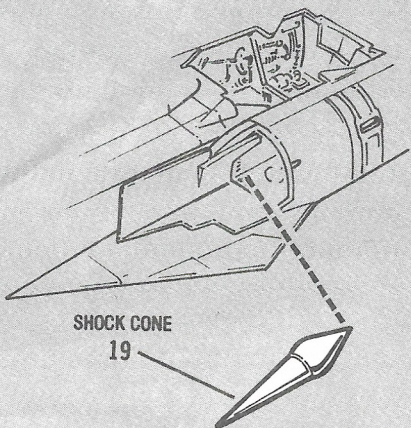
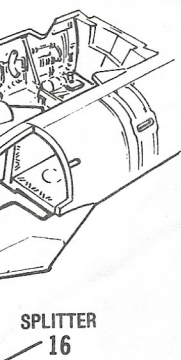
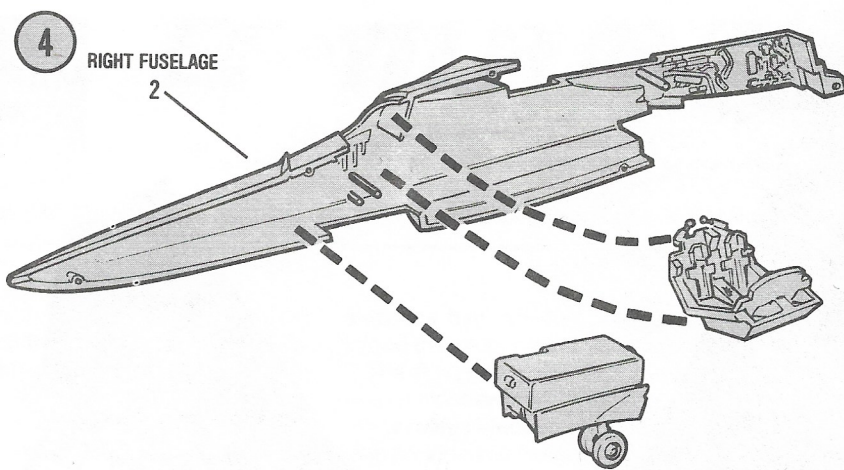
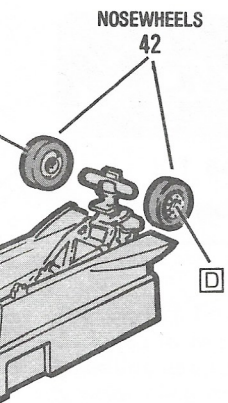

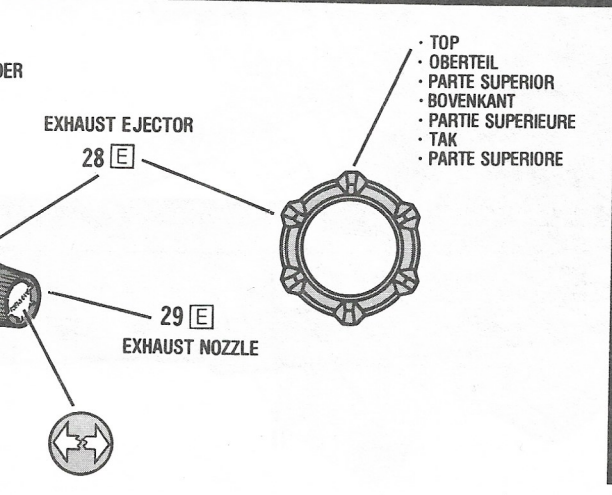
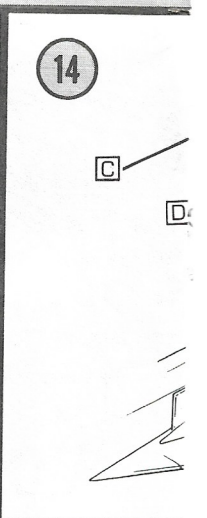
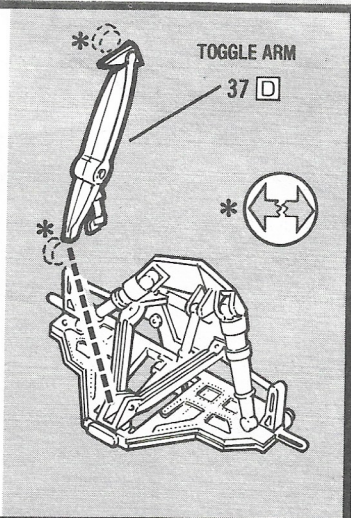
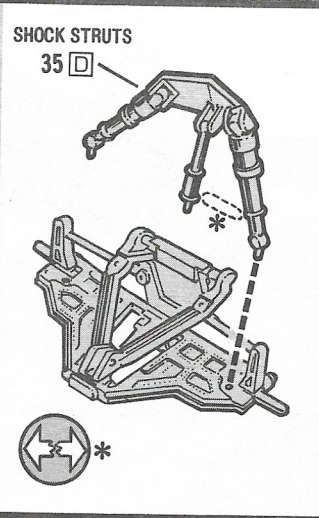
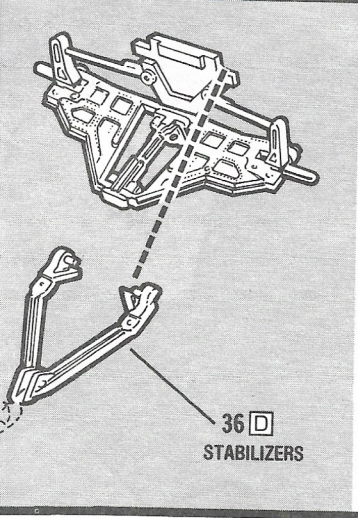
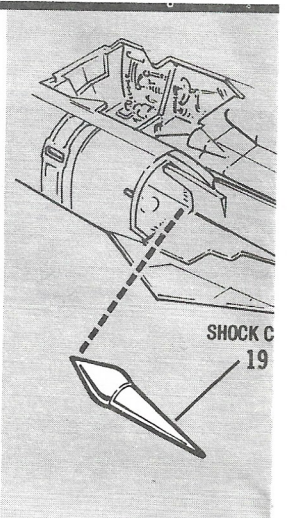
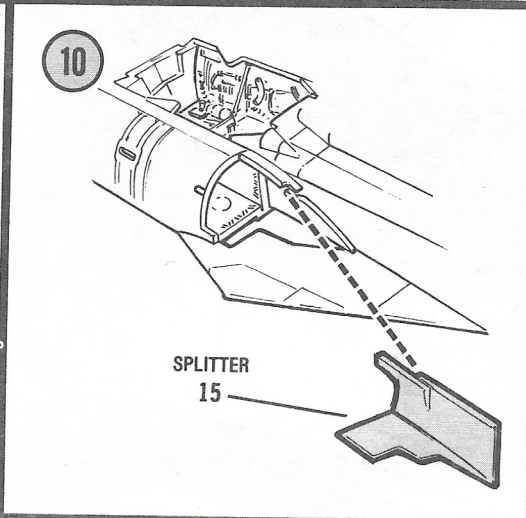
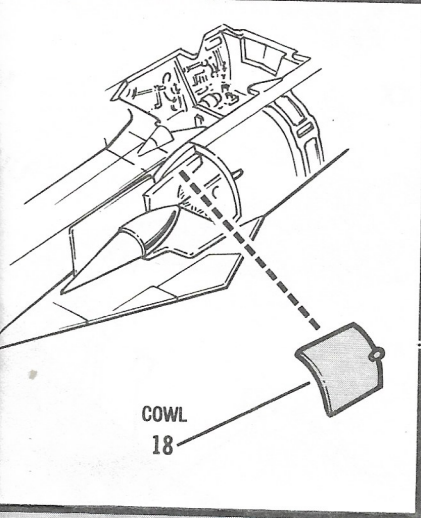
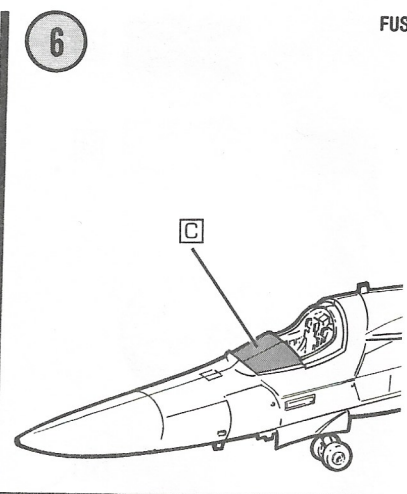
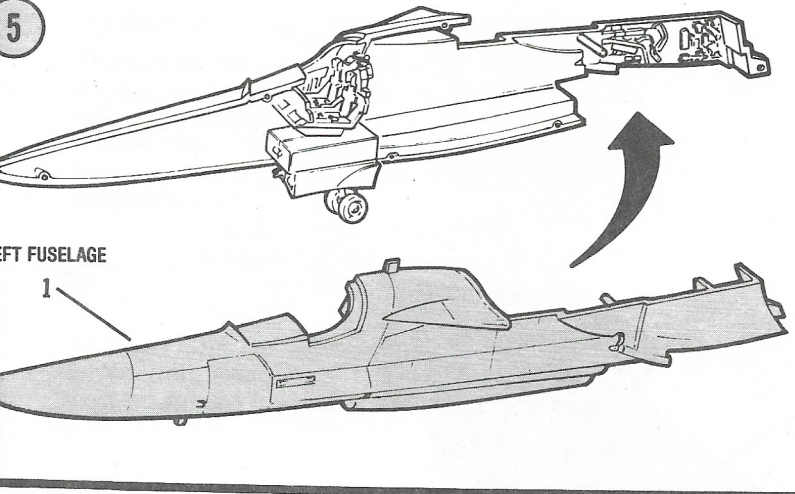

- TOP
- OBERTEIL
- PARTE SUPERIOR
- BOVENKANT
- PARTIE SUPERIEURE
- TAK
- PARTE SUPERIORE

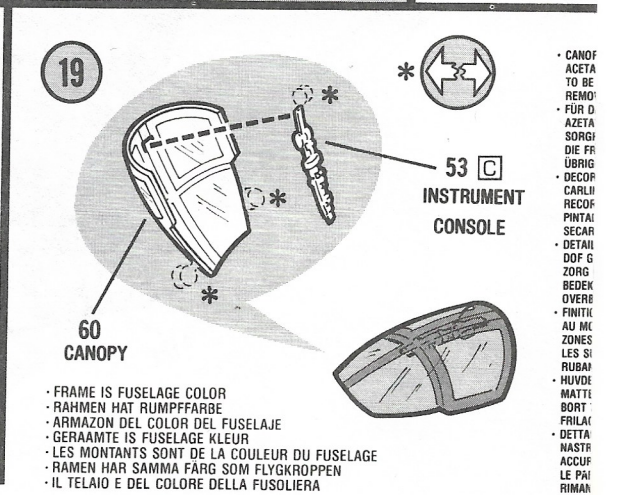

19

14

- FRAME IS FUSELAGE COLOR
- RAHMEN HAT RUMPFARBE
- ARMAZON DEL COLOR DEL FUSELAJE
- GERAAMTE IS FUSELAGE KLEUR
- LES MONTANTS SONT DE LA COULEUR DU FUSELAGE
- RAMEN HAR SAMMA FARG SOM FLYGKROPPEN
- IL TELAIO E DEL COLORE DELLA FUSOLIERA

- CANOP
- ACETA
- TO BE
- REMO
- FÜR D
- AZETA
- SORGI
- DIE FR
- ÜBRIG
- DECOP
- CARLI
- RECOF
- PINTAL
- SECAR
- DETAN
- DOF G
- ZORG
- BEDEK
- OVBRE
- FINITL
- AU MC
- ZONES
- LES SI
- RUBAN
- HUVDE
- MATTE
- BORT
- FRILAC
- DETTA
- NASTR
- ACCUF
- LE PAI
- RIMAN

PLAGE BOTTOM

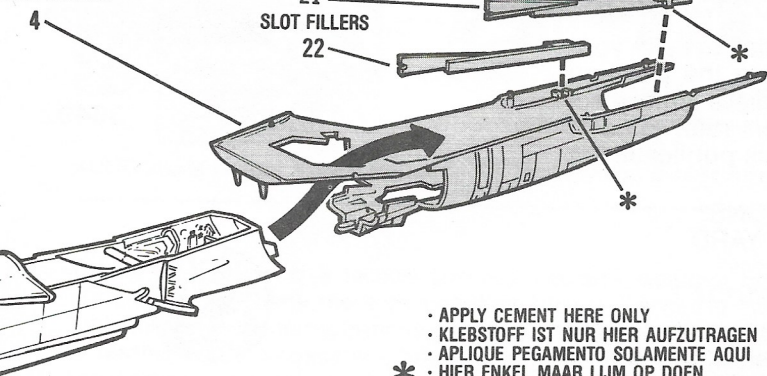

- APPLY CEMENT HERE ONLY
- KLEBSTOFF IST NUR HIER AUFZUTRAGEN
- APLIQUE PEGAMENTO SOLAMENTE AQUI
- * • HIER ENKEL MAAR LIJM OP DOEN
- APPLIQUER LA COLLE ICI SEULEMENT
- SÄTT ENDAST PÅ LIM HÄR
- APPLICARE L'ADESIVO SOLO QUI

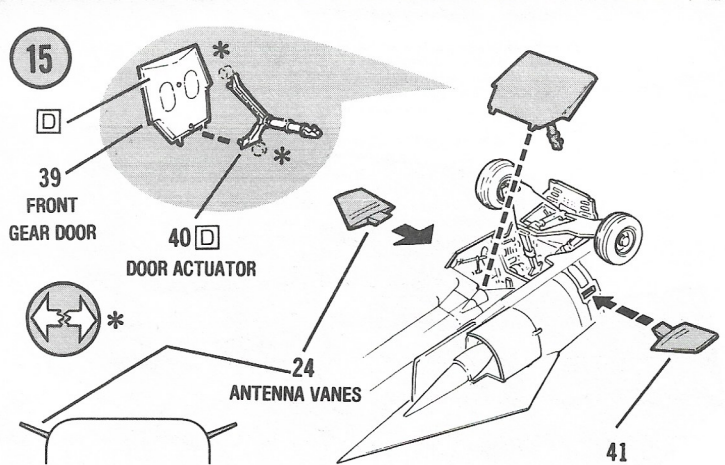
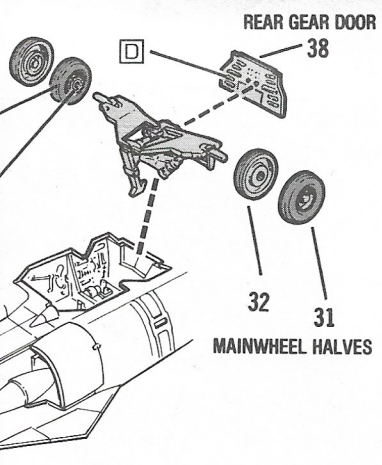
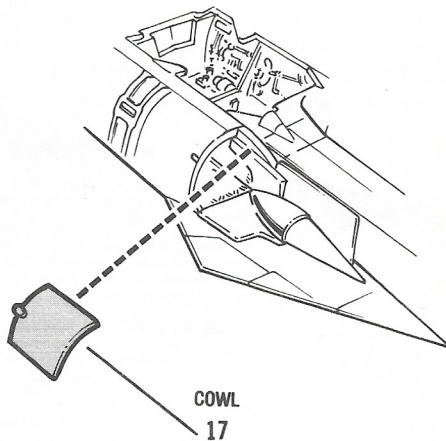
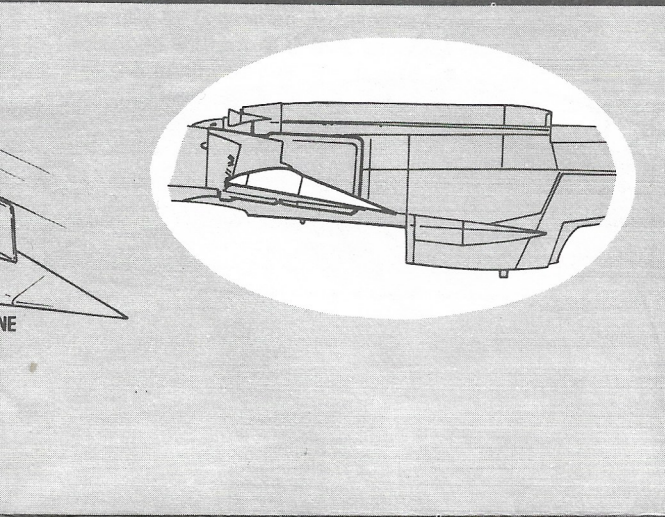
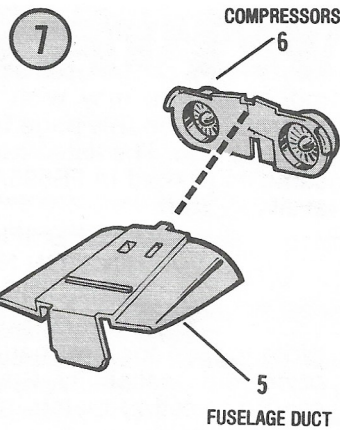

DETAIL—MASK ENTIRE CANOPY WITH A DULL FINISH
 MENDING TAPE. CAREFULLY CUT THE TAPE FROM AREAS
 ANTEN. PAINT THE EXPOSED PARTS AND ALLOW TO DRY.
 HE REMAINING TAPE.

KUPPELDACH—DAS GESAMTE KUPPELDACH MIT MATTEM
 KLEBSTREIFEN VERKLEIDEN. DEN KLEBSTREIFEN
 GIG VOR DEN ZU STREICHENDEN FLÄCHEN ABSCHNEIDEN.
 V TELLE STREICHEN UND TROCKNEN LASSEN. DEN
 KLEBSTREIFEN ENTFERNEN.

ON DE LA CARLINGA—CUBRIR ENTERAMENTE LA
 CON LA CINTA DE PEGAR DE COLOR ACETATO APAGADO.
 CUIDADOSAMENTE LA CINTA. DE LAS AREAS A SER
 PINTE LAS PARTES QUE QUEDEN EXPUESTAS Y DEJE
 STIRE LA CINTA DE PEGAR.

WAN KOEPELDACH—BEDEK DE GEHELE KOEPELDACH MET
 ZENDE ACETATE VERSTEL BAND. KNIP DE BAND MET
 VAN DE TE VERVEN OPPERVLAKTEN. VERF DE NIET
 DELEN EN LAAT ZE DROGEN. VERWIJDER DE
 ENDE BAND.

DE LA VERRIERE—COUVRIR ENTIEREMENT LA VERRIERE
 DE RUBAN ADHESIF D'ACETATE MAT. DEGAGEZ LES
 PEINDRE EN DECOUPANT LE RUBAN AVEC SOIN. PEINDRE
 ACES DEGAGEES ET LAISSER SECHER. ENLEVER LE
 STANT.

ERING—MASKERA HELA HUVEN MED EN
 ANDLAD ACETATE LAGNINGSTAP. SKÄR FÖRSIKTIGT
 EN FRÅN OMRÅDEN SOM SKALL MÅLAS. MÅLA DE
 YTORN OCH LÅT TORKA. TA BORT KVÄRVARANDE TEJ.
 CALOTTA—MASCHERARE O'INTERA CALOTTA CON UN
 ACETATO A FINITURA OPACA. RITAGLIARE
 MENTE IL NASTRO DALLE AREE DA DITINGERE. DITINGERE
 SPORTE E LASCIAR ASCIUGARE. TOGLIERE IL NASTRO
 E.

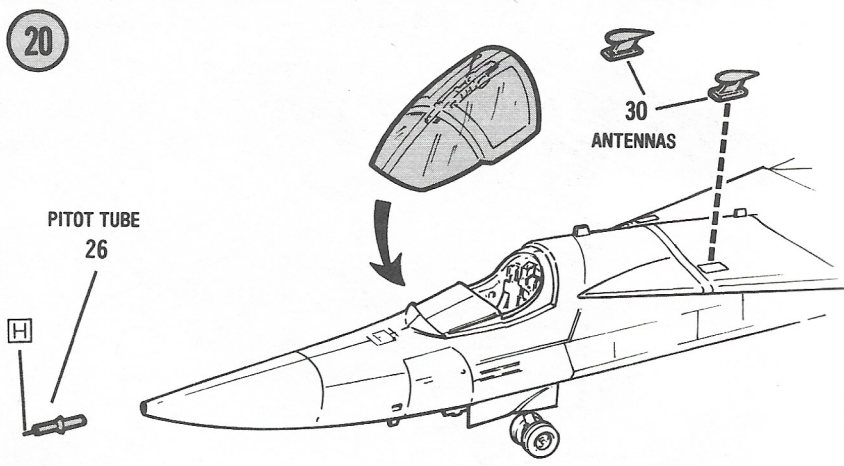

FEDERAL STANDARD COLOR NUMBERS

The box top can be used as a guide to paint your model, or you may wish to use the painting information on this page to achieve a more accurate finish. The listed numbers refer to color samples printed in FS595A. This publication is available from:

GSA - SPECIFICATIONS
WASHINGTON NAVY YARD
BUILDING 197,
WASHINGTON, D.C. 20407

Write to GSA for information regarding current price and availability. Standard hobby paints can be mixed to match the color samples.

A  36320

B  36492

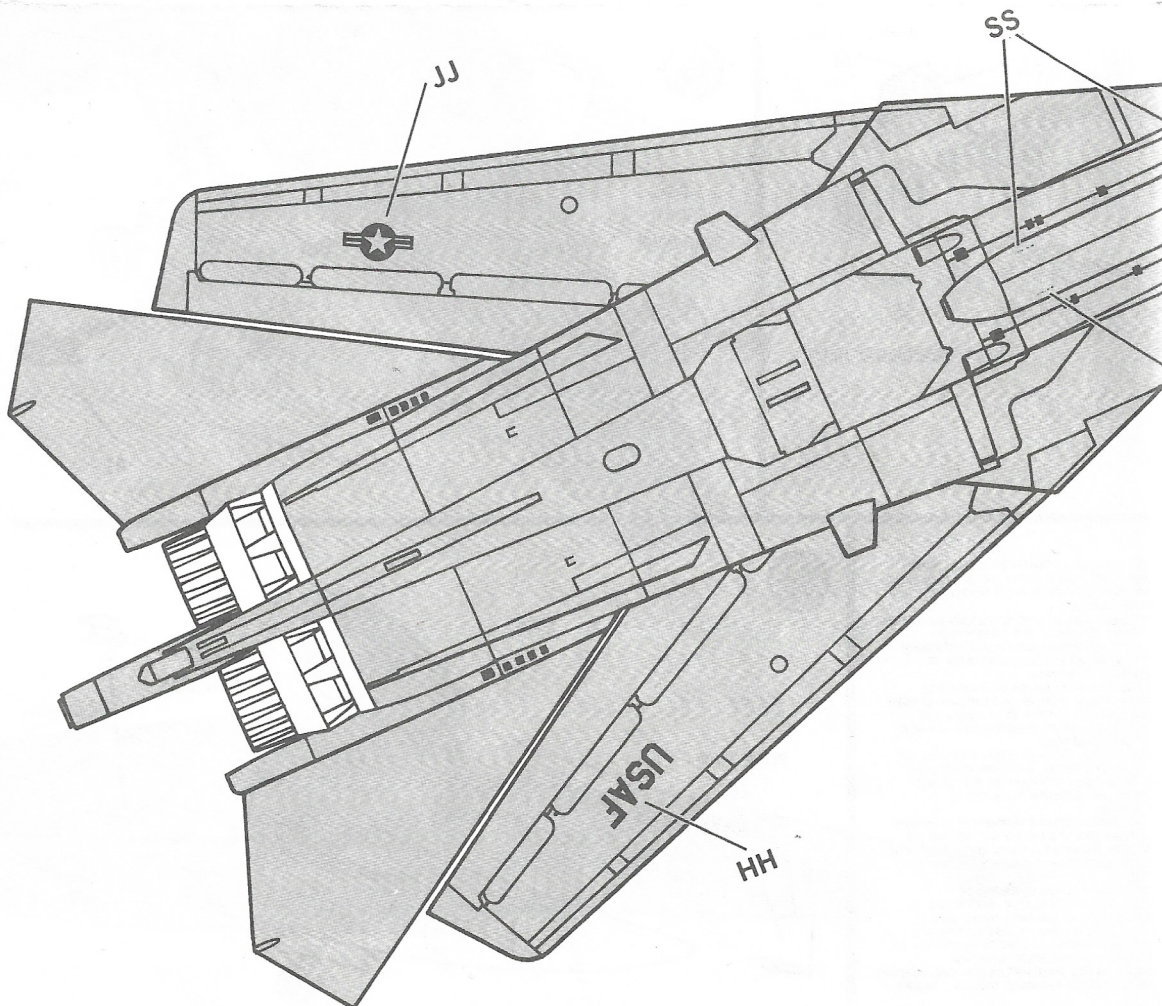
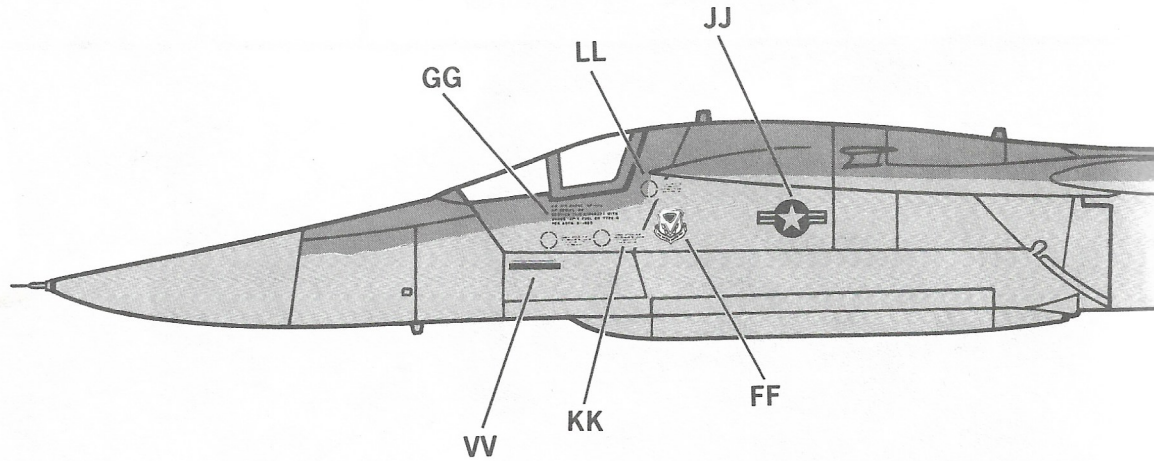

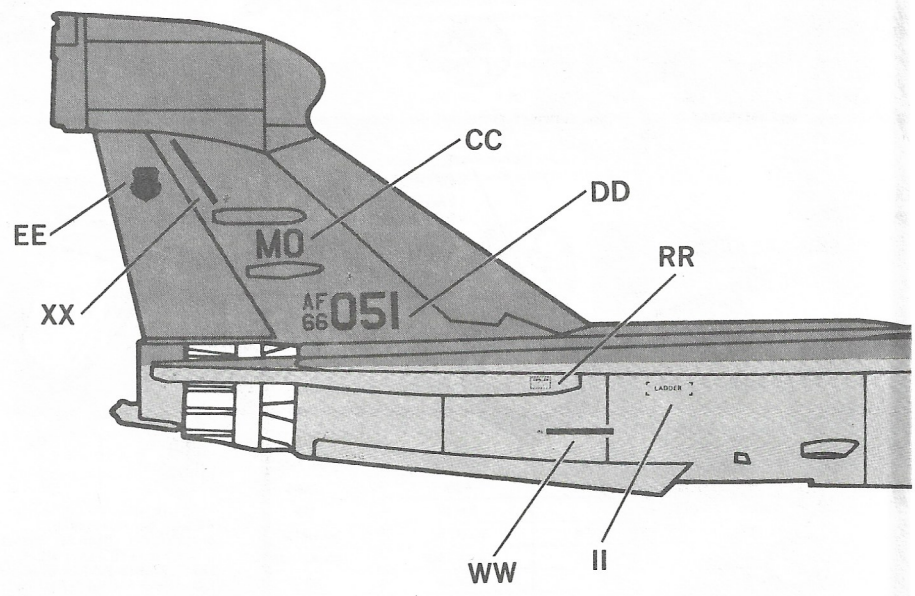
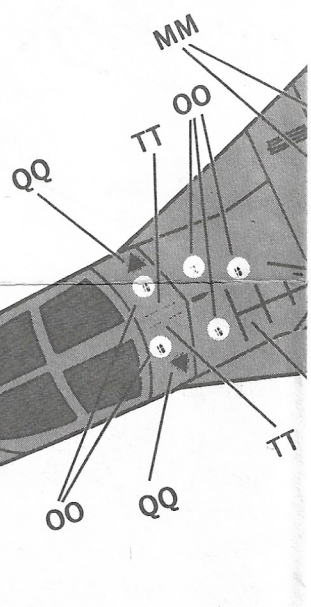
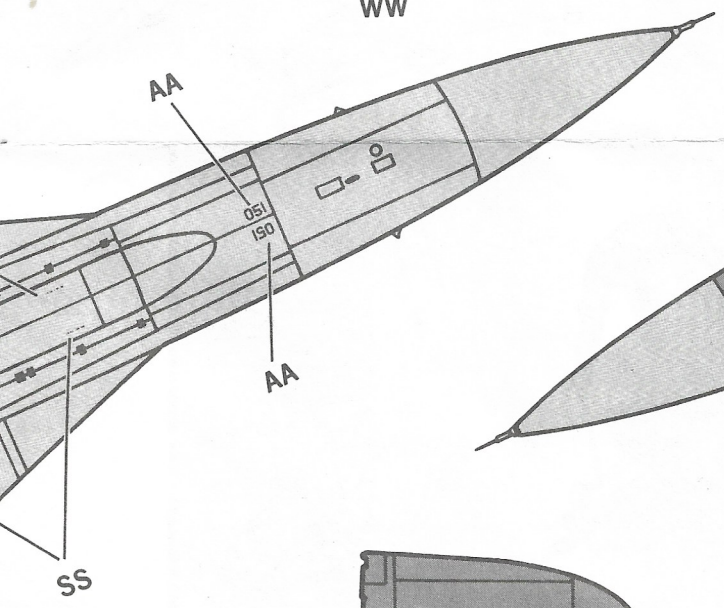
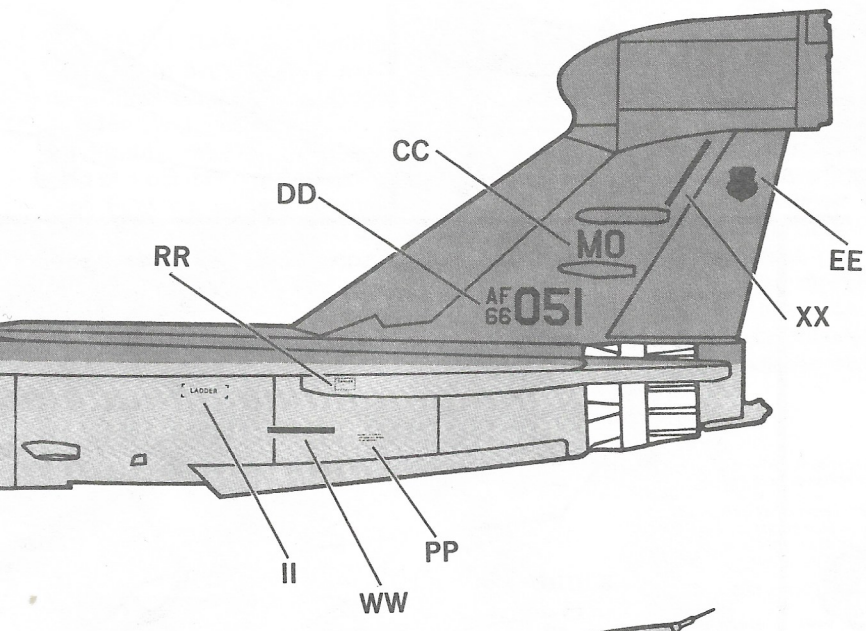

HH

M
U

