



KIT5521

85552100200

A-10 WARTHOG

During the war in Vietnam, the Air Force discovered that its fighter-bombers were not very good at providing close air support (CAS) to troops on the ground. What was needed was an aircraft like the attack types used by the U.S. Navy, and to fill this need, the Air Force first acquired surplus Navy A-1 Skyraiders. Next, the Air Force developed its own version on the Navy's proven A-7 Corsair II, but the Air Force wanted a dedicated attack and close air support aircraft of its own design. This led to the development of the A-10 Thunderbolt II, which, because of its ungainly looks, became commonly known as the Warthog. Designed around a seven-barrel, 30-mm cannon, which fires depleted Uranium rounds capable of piercing a considerable thickness of armor, the Warthog quickly became known as a tank buster. Additionally, eleven pylons under the wings and fuselage can carry a wide variety of ordnance including standard bombs, cluster bombs, and guided missiles. But the A-10 not only has a lot of firepower, its also designed to be very survivable. The pilot sits in an armored "bathtub" to protect him from ground fire. The Warthog can fly safely with either one of its

twin tails shot away and the two turbofan engines are mounted high above the tail to protect them from anti-aircraft artillery. The tail surfaces also shield the engines from heat seeking missiles. During Operations Desert Storm and Iraqi Freedom, A-10s were very successful at destroying hundreds of tanks and other armored vehicles belonging to the Republican Guard and other units of the Iraqi Army. Quite often Warthogs returned safely to their base with extensive battle damage that would have downed other aircraft. Your Revell kit of the A-10 comes with two sets of markings in different paint schemes. One is from the 104th Tactical Fighter Squadron on the 175th Tactical Fighter Group which is part of the Maryland Air National Guard. It is named "NORRIS THE PLAYHOG" and is painted in the European I scheme. The other aircraft is named "Lets Roll" and is painted in the two-toned gray scheme. It was assigned to the 345th Fighter Squadron of the 355th Fighter Wing at Davis-Monthan Air Force Base, Arizona.



*** REPEAT SEVERAL TIMES**
* A REPETER PLUSIEURS FOIS



*** OPTIONAL PARTS**
* PIECES EN OPTION



*** DECAL**
* DECAL COMANIE



*** ALTERNATIVE ASSEMBLY**
* ENSEMBLAGE ALTERNATIVE



*** CEMENT TOGETHER**
* A COLLER



*** REMOVE AND THROW AWAY**
* A RETIRER ET JETER



*** DO NOT CEMENT**
* NE PAS COLLER

READ THIS BEFORE YOU BEGIN

- * Study the assembly drawings.
- * Each plastic part is identified by a number.
- * For better paint and decal adhesion, wash the plastic parts in a mild detergent solution. Rinse and let air dry.
- * Check the fit of each piece before cementing in place.
- * Use only cement for polystyrene plastic.
- * Scrape paint from areas to be cemented.
- * Allow paint to dry thoroughly before handling parts.
- * Any unused parts may be discarded.

DECAL APPLICATION INSTRUCTIONS

1. Cut desired decal from sheet.
2. Dip decal in water for a few seconds.
3. Place wet decal on paper towel.
4. Wait until decal is movable on paper backing.
5. Place decal in position on model, face up and slide backing away.
6. Press out air bubbles with a soft damp cloth.
7. Milkiness that may appear is for better decal adhesion and will dry clear. Wipe away any excess adhesive.
8. Do not touch decal until fully dry.
9. Allow the decals 48 hours to dry before applying clear coat.

NOTE: Decals are compatible with setting solutions or solvents.

LIRE CE QUI SUIT AVANT DE COMMENCER

- * Etudier les schémas de montage.
- * Chaque pièce en plastique est identifiée par un numéro.
- * Pour une meilleure prise de la peinture et des autocollants, laver les pièces en plastique avec une solution détergente peu concentrée. Les rincer et les laisser sécher à l'air.
- * Vérifier que chaque pièce s'ajuste bien avant de la coller en place.
- * N'utiliser que de la colle pour polystyrène.
- * Gratter les parties à coller pour enlever la peinture.
- * Laisser la peinture bien sécher avant de manipuler les pièces.
- * Toute pièce inutilisée peut être jetée.

DIRECTIVES D'APPLICATION DES AUTOCOLLANTS

1. Découper l'autocollant désiré de la feuille.
2. Tremper l'autocollant dans de l'eau pendant quelques secondes.
3. Placer l'autocollant mouillé sur une serviette en papier.
4. Attendez que l'autocollant puisse être déplacé sur son support en papier.
5. Mettre l'autocollant en position sur le modèle face sur le dessus et faire glisser le support pour l'enlever.
6. Appuyer avec un chiffon doux humide pour éliminer les bulles d'air.
7. La substance laiteuse qui peut apparaître est destinée à améliorer l'adhésion de l'autocollant et devient incolore au séchage. Essuyer pour enlever tout excédent d'adhésif.
8. Ne pas toucher l'autocollant tant qu'il n'est pas bien sec.
9. Laisser l'autocollant sécher pendant 48 heures avant d'appliquer une couche transparente.

REMARQUE: Les autocollants sont compatibles avec les solutions de fixation ou les solvants.

This optional paint guide is provided if you choose to detail paint your model.

Ce guide de peinture vous sera fourni si vous choisissez de peindre votre modèle en détail.

Aluminum		Aluminium
Chrome		Chrome
Dark Gray	FS 36081	Gris foncé
Dark Green	FS 34092	Vert foncé
Dark Gull Gray	FS 36231	Gris cendré foncé
Flat Black	FS 37038	Noir mat
Gray	FS 36270	Gris
Green		Vert
Gloss Black	FS 17038	Noir brillant
Gloss White	FS 17875	Blanc brillant
Gunmetal		Bronze
Light Gray	FS 36559	Gris clair
Light Green	FS 34102	Vert clair
Olive Drab	FS 34087	Gris vert
Olive Green	FS 34095	Vert olive
Red	FS 11136	Rouge
Satin White		Blanc satiné
Silver		Argent
Steel		Acier
Tan		Havane
Yellow	FS 13538	Jaune

If you have any questions or comments, call our hotline at: **(800) 833-3570**
or, please write to:

Revell-Monogram Consumer Service Department, 725 Landwehr Road, Northbrook, Illinois 60062

Be sure to include the plan number ((85552100200), part number, description, your return address and phone number.

Visit our website: www.revell-monogram.com

1

COCKPIT AND FUSELAGE ASSEMBLY

A

NOTE: THE USE OF THE PILOT FIGURE IS OPTIONAL

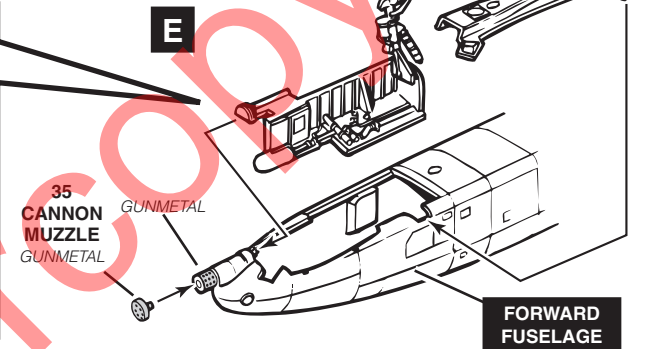
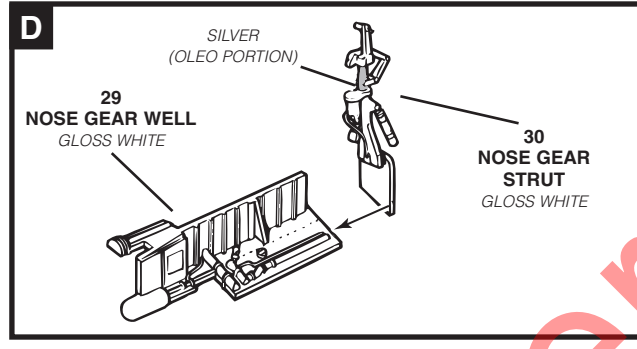
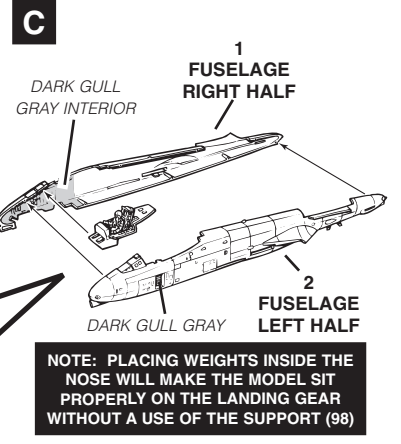
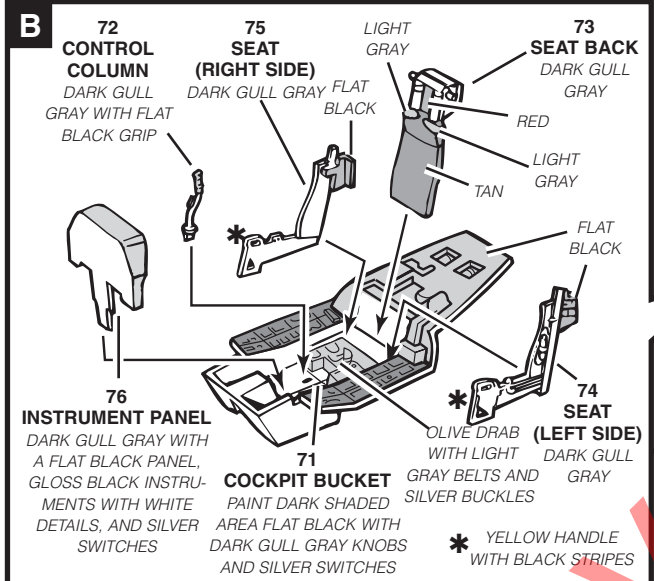
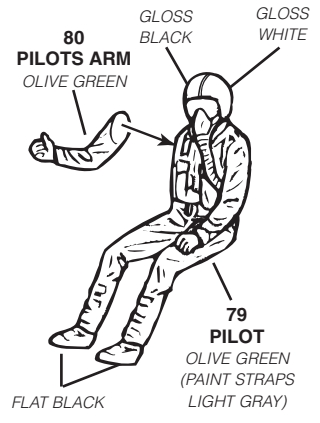

2

ENGINE AND WING ASSEMBLY

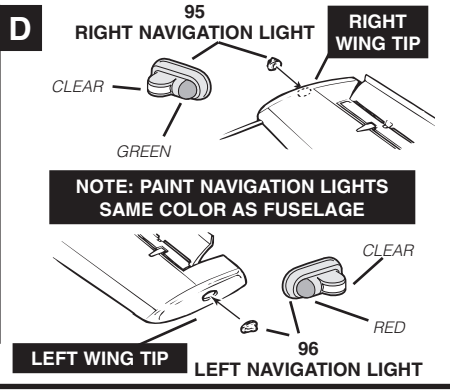
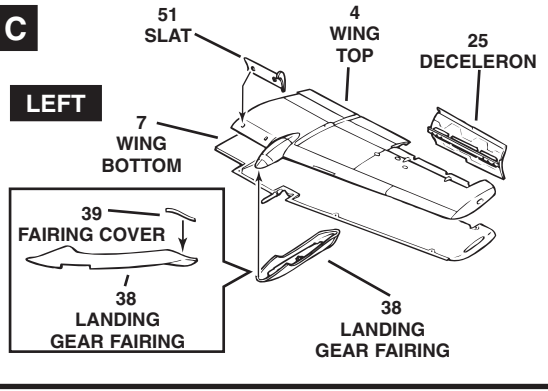
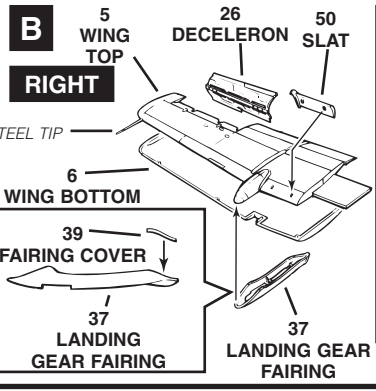
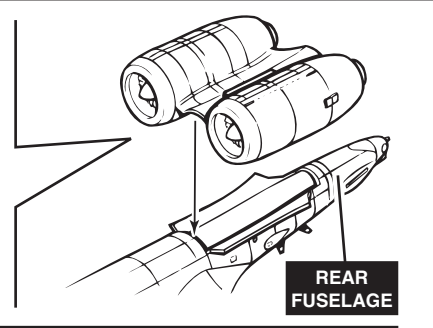
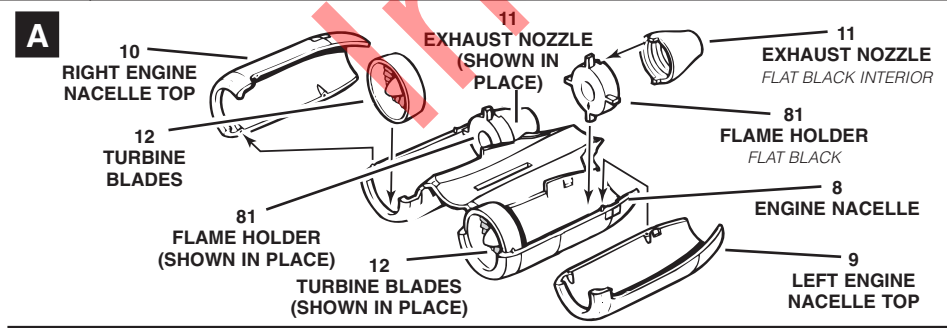

2

WING ASSEMBLY CONTINUED

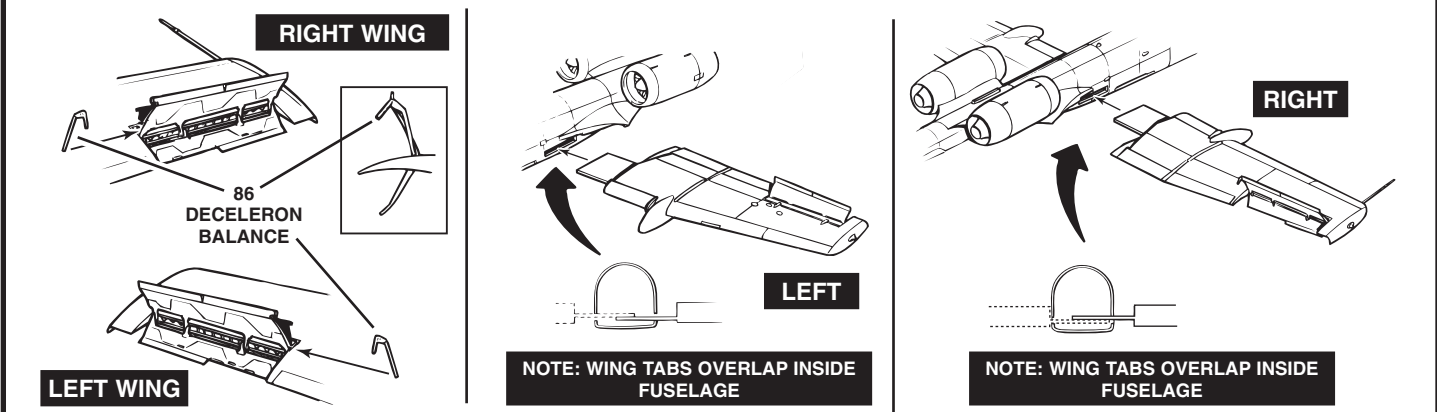

3

TAIL ASSEMBLY

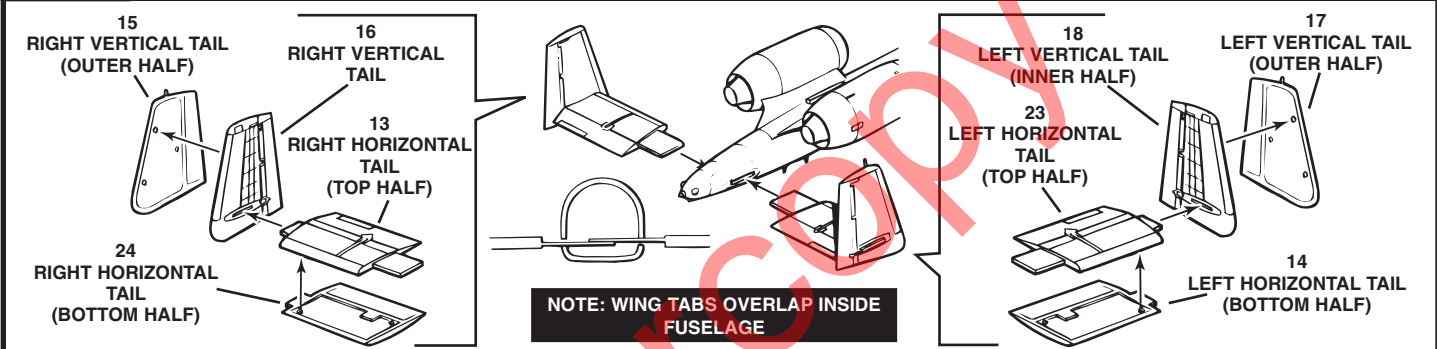

4

MAIN LANDING GEAR ASSEMBLY

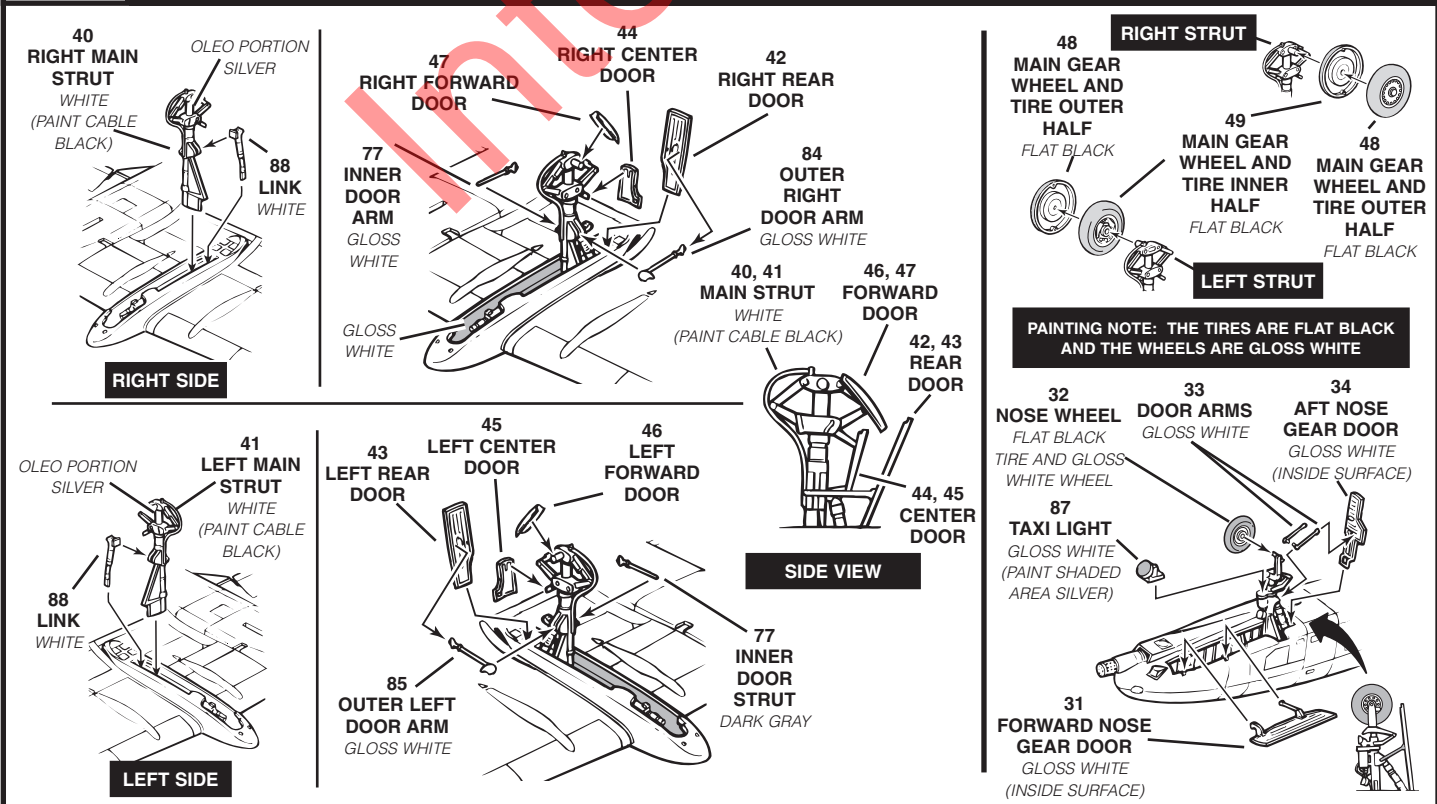

5

GENERAL ASSEMBLY

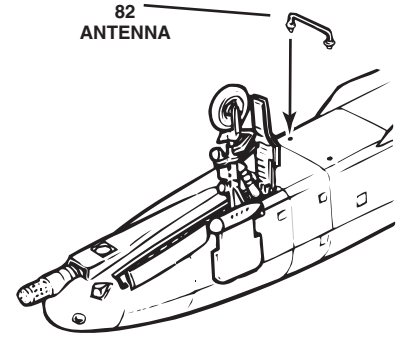
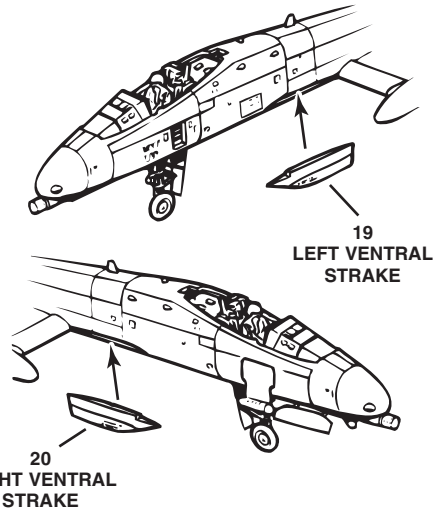
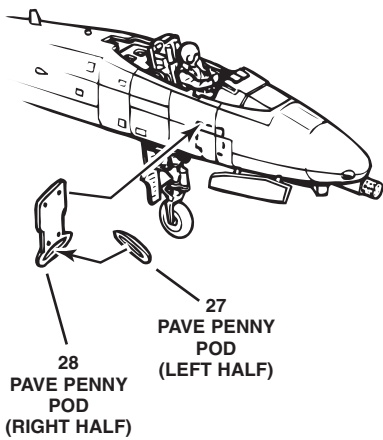

6

CANOPY AND PYLON ASSEMBLY

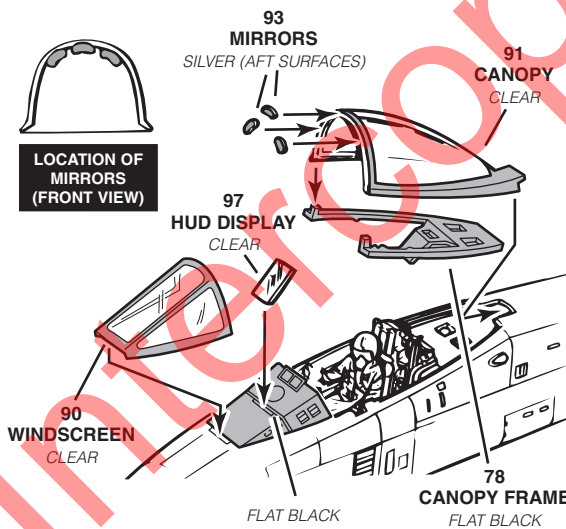
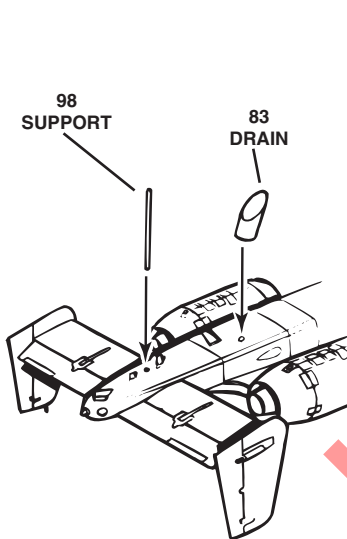

NOTE: PAINT FRAMEWORK ON THE WINDSCREEN AND CANOPY THE SAME COLOR AS THE SURROUNDING FUSELAGE

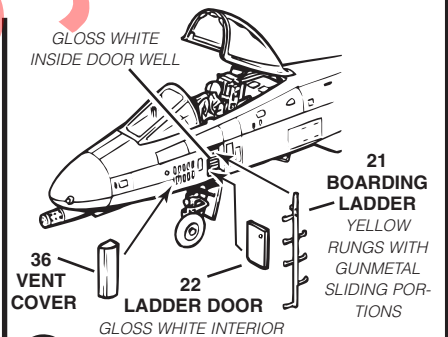

LOWERED POSITION

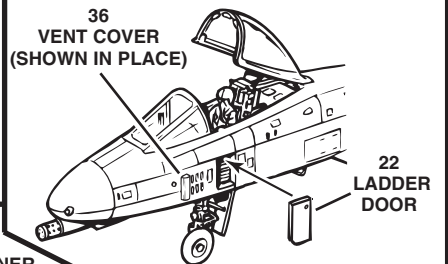

RAISED POSITION

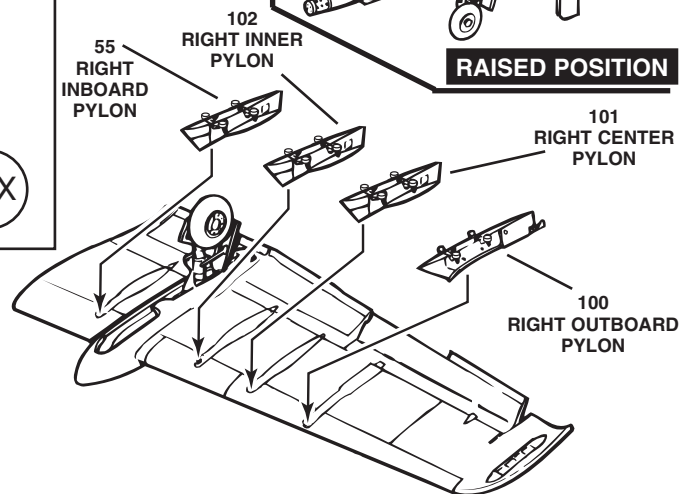
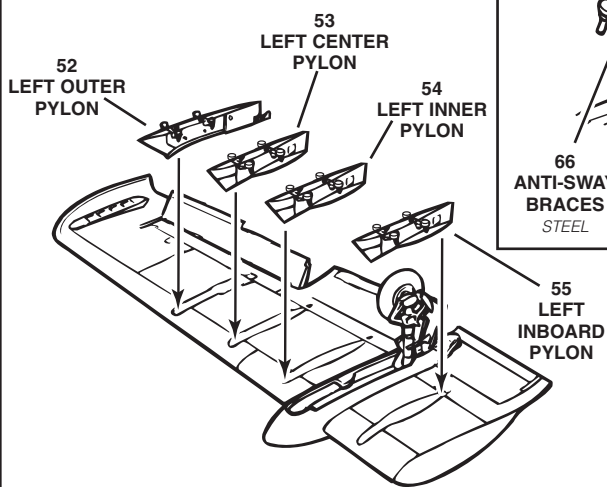

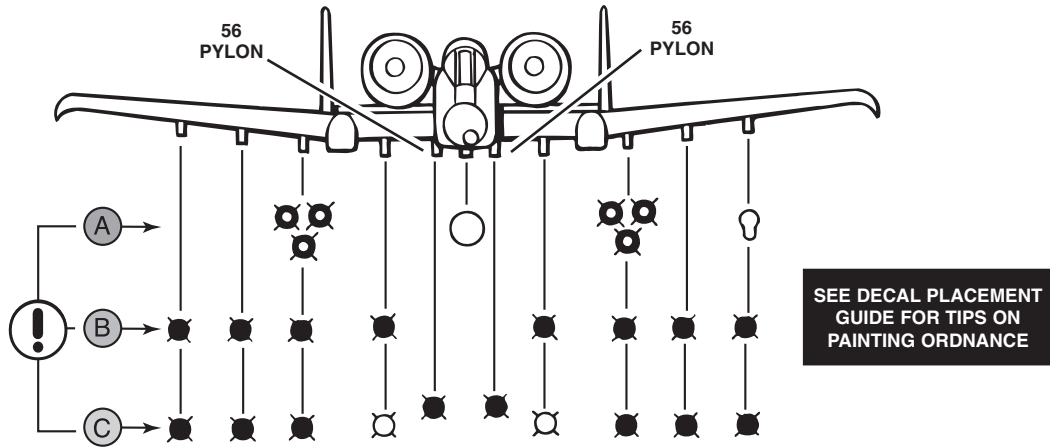

A 1

(2X)

59 LOWER LAUNCH RAIL

58 SIDE LAUNCH RAIL

PYLON

NOTE: LAUNCH RAILS ARE THE SAME COLOR AS THE UNDERSIDE OF THE AIRCRAFT

A 2

(6X)

A6M-65 MAVERICK MISSILE

60 MAVERICK MISSILE HALF SATIN WHITE

94 NOSE CLEAR (PAINT BACK OF HEAD BLACK)

61 MAVERICK MISSILE HALF SATIN WHITE

NOTE: A6M-65A AND A6M-65B MAVERICK MISSILES ARE SATIN WHITE. A6M-65D MAVERICK MISSILES ARE OLIVE DRAB. ALL THREE HAVE THE SAME EXTERNAL APPEARANCE

A 3

(2X)

COMPLETED MAVERICK MISSILES

COMPLETED LAUNCH RAIL

A 4

FUEL TANK

68 FUEL TANK HALF PAINT FUEL TANK OLIVE DRAB OR LIGHT GRAY

67 FUEL TANK HALF PAINT FUEL TANK OLIVE DRAB OR LIGHT GRAY

COMPLETED FUEL TANK

57 CENTERLINE PYLON

A 5

ECM POD

62 ECM POD RIGHT HALF OLIVE DRAB

63 ECM POD LEFT HALF OLIVE DRAB

FLAT BLACK

COMPLETED ECM POD

52 PYLON

B

(8X)

65 CLUSTER BOMB HALF OLIVE DRAB

64 CLUSTER BOMB HALF OLIVE DRAB

COMPLETED CBU-52

STEEL

PYLON

C

(2X)

NAPALM BOMB

69 NAPALM BOMB HALF ALUMINUM

70 NAPALM BOMB HALF ALUMINUM

PYLON

A-10A THUNDERBOLT II, 78-0683, "NORRIS THE PLAYHOG", 104th TACTICAL FIGHTER SQUADRON, 175th TACTICAL FIGHTER GROUP, MARYLAND AIR NATIONAL GUARD, AUGUST 18, 1989.

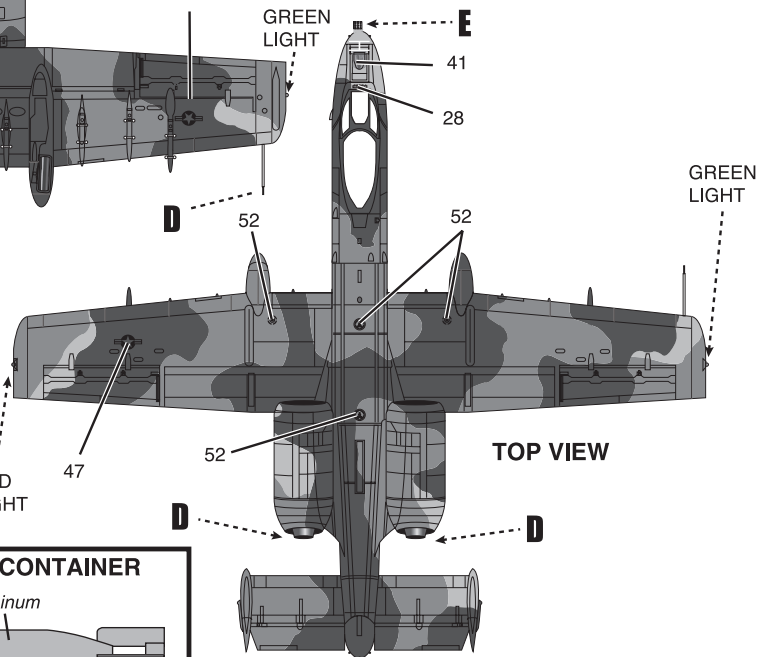
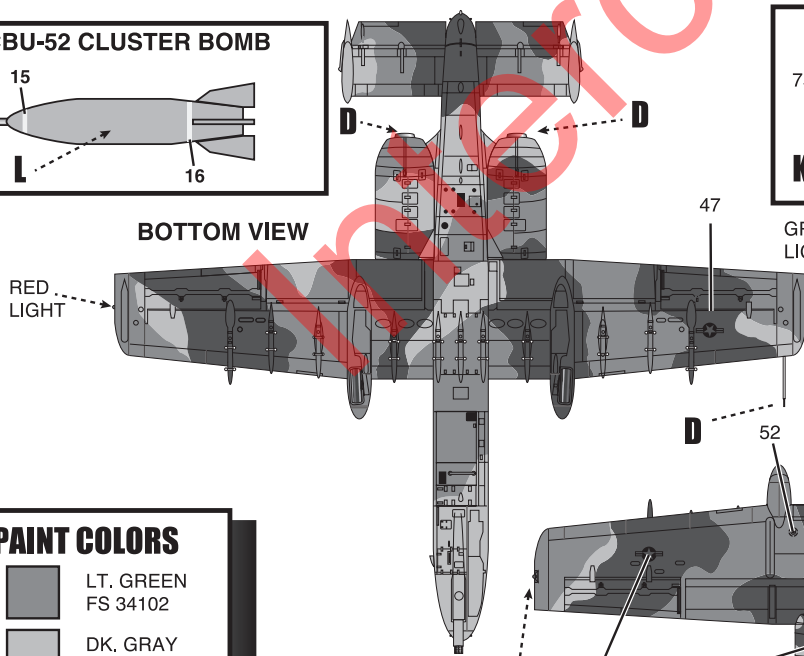
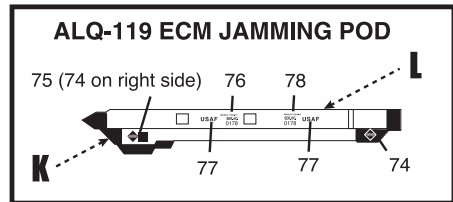
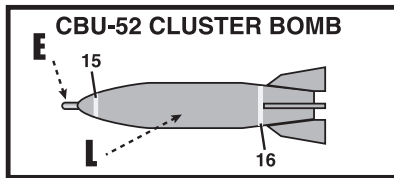
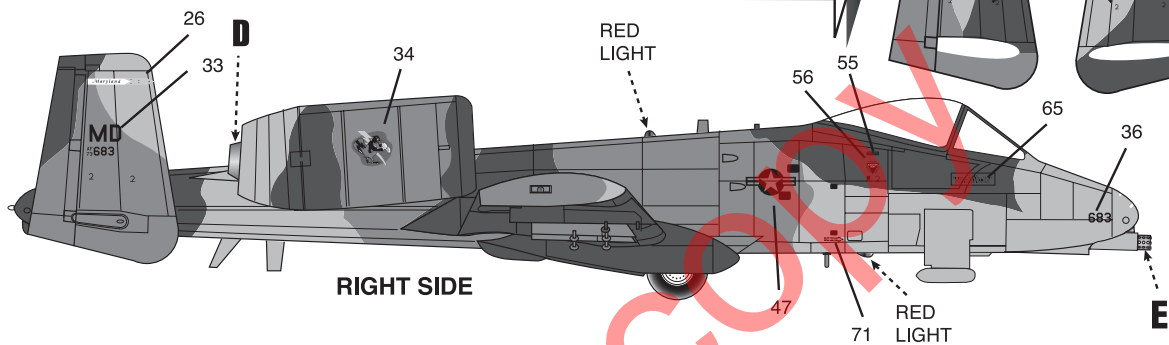
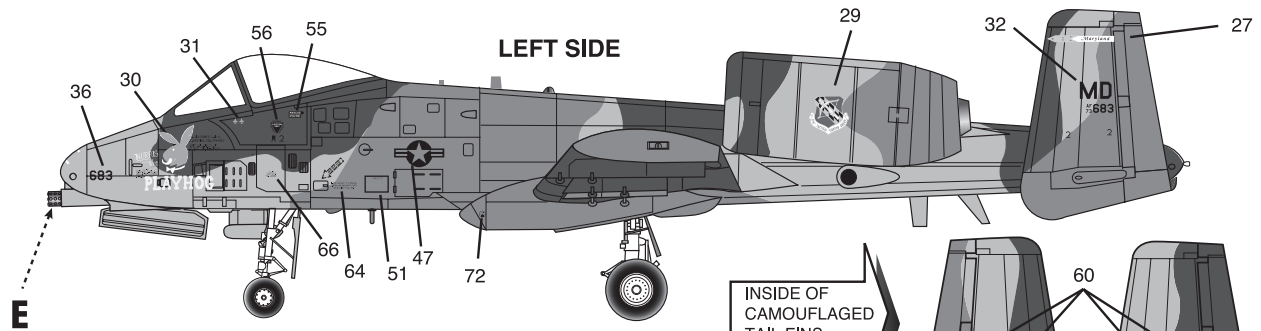

PAINT COLORS	
A	LT. GREEN FS 34102
B	DK. GRAY FS 36081
C	DK. GREEN FS 34092
D	STEEL
E	GUNMETAL

