

G.W.H.[®]

1/48
SCALE
L4825



A-10A 雷電二式 近距离支援攻击机
THUNDERBOLT II
CLOSE AIR SUPPORT ATTACK AIRCRAFT

注意事項 CAUTION 組み立てのご注意

- (1) 勿于近火处使用胶水或油漆, 并打开窗户保持空气流通。
- (2) 涂料的号码请参考本栏以下的说明。本品本身不包括胶水和涂料。
- (3) 自板件中取出部件时, 应用模型专用剪, 并用介刀或小锉除去多余胶料。
- (4) 各图形的含义可参考本栏以下说明。

- (1) When you use glue or paint, do not use near a open flame, and use in a well-ventilated room.
- (2) See below for the color list. Glue and paint are not included in the kit.
- (3) When you take parts off the runner frame, use the modeling scissors and trim excess plastic with a cutter or a file.
- (4) See below for the meaning of symbols.

- (1) 接着剂や塗料は火の近くで使わないで下さい、使用の際は換気をよくして下さい。
- (2) 塗料指定のは下記のとおりです、接着剂や塗料は入っていませんので別に求めて下さい。
- (3) 部品のランナーから切り離す時は模型用ハサミ等を使い、余分な部分はカッターやヤスリ等で仕上げして下さい。
- (4) 組立図のサインマークは下の説明を御覧下さい。

图形含义 CAUTION マーク

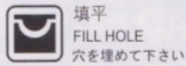

填平
FILL HOLE
穴を埋めて下さい

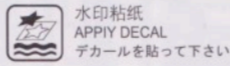

水印粘纸
APPLY DECAL
デカルを貼って下さい

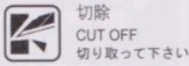

切除
CUT OFF
切り取って下さい



弯折
BEND
折り曲げて下さい

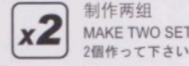

制作两组
MAKE TWO SET
2個作って下さい

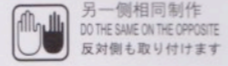

另一側相同制作
DO THE SAME ON THE OPPOSITE
反対側も取り付けます

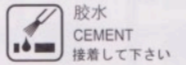

胶水
CEMENT
接着して下さい

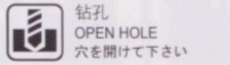

钻孔
OPEN HOLE
穴を開けて下さい

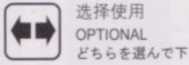

选择使用
OPTIONAL
どちらを選んで下さい

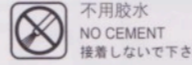

不用胶水
NO CEMENT
接着しないで下さい

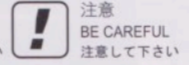

注意
BE CAREFUL
注意して下さい

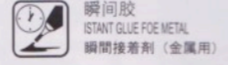

瞬间胶
INSTANT GLUE FOR METAL
瞬間接着剂 (金属用)

所使用工具 RECOMMENDED TOOLS 専用工具

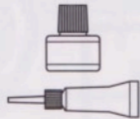

塑胶件用模型胶水
Cement
プラスチック用接着剂

模型用瞬间胶水
Instant Cement
瞬間接着剂

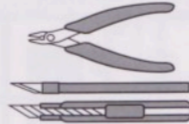

模型用剪钳
Side cutters
模型用ニッパー

模型用刻刀
Modeling knife
模型用ナイフ

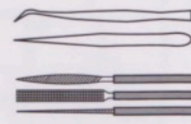

模型用镊子
Tweezers
ピンセット

模型用锉刀
Diamond file
模型用ヤスリ

水贴纸使用说明 DECAL APPLICATION スライドマークの貼り方

- (1) 用模型剪刀或刻刀切下所需的图案部分。
- (2) 将水贴纸浸泡在温水中10秒左右取出放置于戏水的干布上。
- (3) 手拿着水贴纸的一角, 用模型镊子小心夹住浮起的水贴图案移至模型表面准确位置。
- (4) 用手指适当沾水均匀涂于水贴图案表面, 使其延展移动至精确位置。
- (5) 用柔软吸水的干布将水贴图案中的气泡向一边挤出, 使水贴在模型表面保持平整。

- (1) Cut off decal from sheet.
- (2) Dip the decal in tepid water for about 10 sec. and place on a clean cloth.
- (3) Hold the backing sheet edge and slide decal onto the model.
- (4) Move decal into position by wetting decal with finger.
- (5) Press decal down gently with a soft cloth until excess water and air bubbles are gone.

- (1) 貼りたいマークをハサミで切り抜きます。
- (2) マークをぬるま湯に10秒ほど浸してからタオル等の布の上に置きます。
- (3) 台紙のはしを手で持ち、貼るところにマークをスライドさせてモデルに移して下さい。
- (4) 指に少し水を付けてマークを濡らしてながら、正しい位置にずらしします。
- (5) 柔らかい布でマークの内側の気泡を押し出しながら、押しつけるようにして水分をとります。

蚀刻片使用说明 PHOTO-ETCHED PARTS エッチングパーツ

- (1) 使用蚀刻片专用剪刀或模型专用刻刀将蚀刻片零件切割下待用。
 - (2) 切割下的零件上有蚀刻片的残留连接点部分, 使用模型专用锉刀细心打模干净。
 - (3) 蚀刻片部分在涂装之前必须使用专用的模型金属底漆打底。
- 注意事项: 蚀刻片很薄外延较为尖锐, 有刮伤手的可能, 在使用之时请务必小心。

- (1) Cut off photo-etched parts using a modeling knife.
 - (2) Carefully remove any excess using a file.
 - (3) Apply metal primer prior to painting.
- Attention, please: Extra care should be taken to avoid personal injury when handling photo-etched parts.

- (1) 切り離す時はカッターナイフを使用してパーツを切り離します。
 - (2) 切り出した時、部品に出張った部品が残っている場合は、ヤスリなどで丁寧に削り落とします。
 - (3) 塗装が必要なパーツは下地にメタルプライマーを吹き着けてから塗装します。
- ご注意: エッチングパーツは大変薄く、手などを切り恐れがあります。取扱いには十分注意して下さい。

涂装色表 PAINT REQUIRED カラー番号リスト

■ C000 GSI CREOS Mr.COLOR

C 2	亮光黑	Black	C 55	卡其色	Khaki color
C 4	亮光黄	Yellow	C 137	轮胎黑	Tire black
C 8	亮光银	Silver	C 214	黑铁	Black iron
C 10	亮光铜	Coppery	C 301	灰FS36081	Grey FS36081
C 28	黑铁色	Black iron	C 302	绿FS34092	Green FS34092
C 33	消光黑	Extinction black	C 303	绿FS34102	Green FS34102
C 47	透明红	Clear red	C 304	橄榄绿FS34084	Green FS34084
C 50	透明蓝	Clear blue	C 305	灰FS36118	Grey FS36118
C 306	灰FS36270	Grey FS36270			
C 307	灰FS36320	Grey FS36320			
C 308	灰FS36375	Grey FS36375			
C 316	白	White			
C 317	灰	Grey			
C 320	浓松叶色	Thick pine leaf			
MC 212	金属灰	Metallic gray			
MC 218	铝金色	Aluminum gold			



A Part × 1

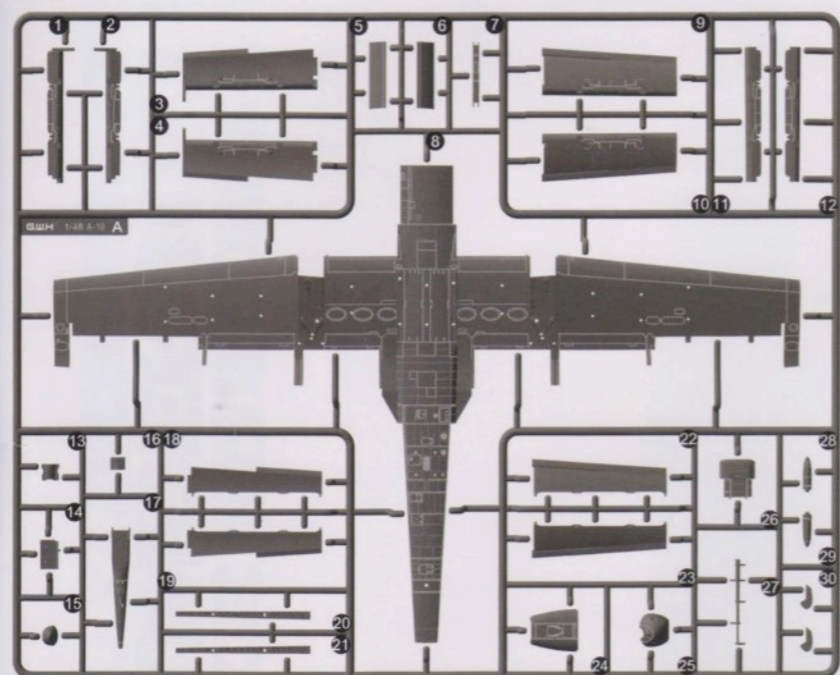

B Part × 1

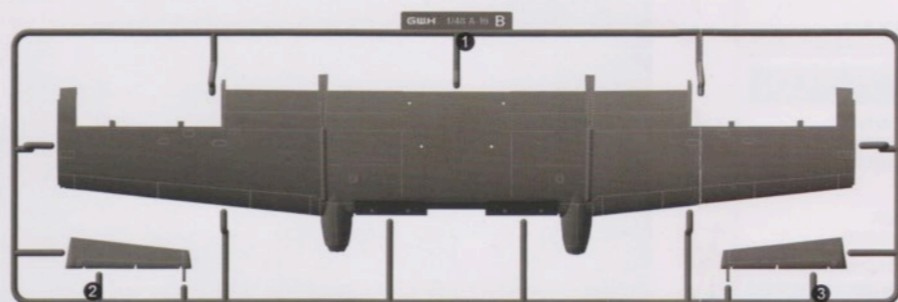

C Part × 1

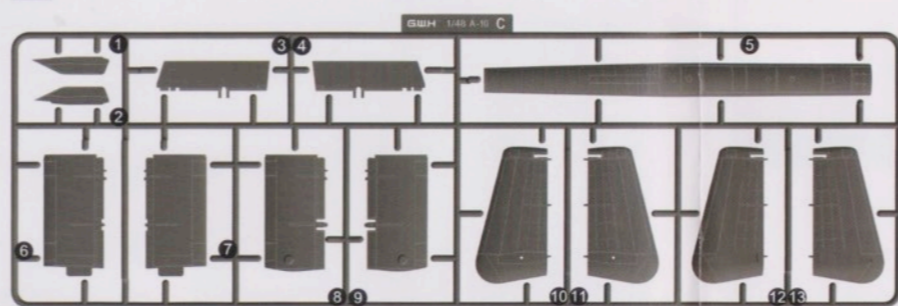

I Part × 1

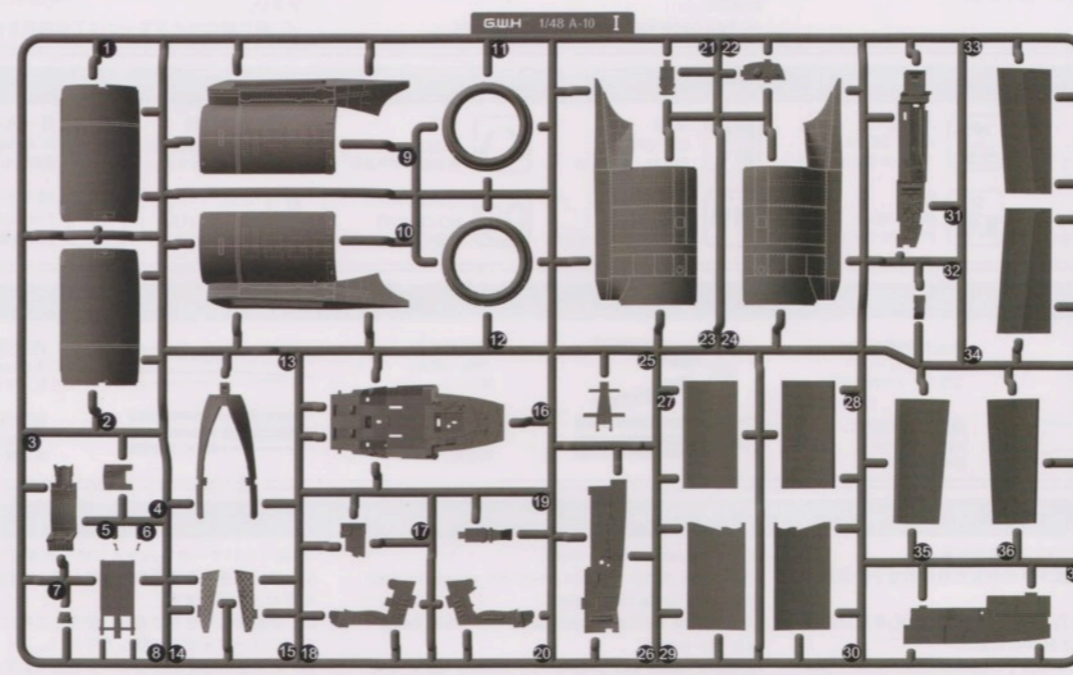

H Part × 1



G Part × 1



E Part × 1



D Part × 1

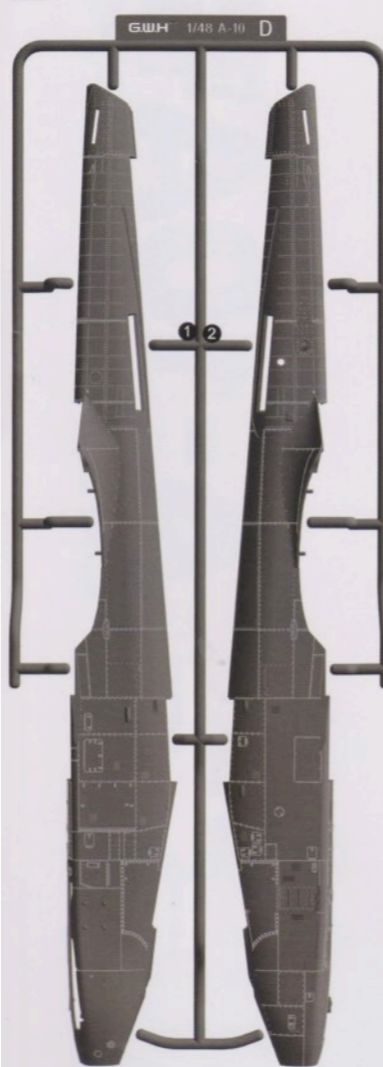

P Part × 1

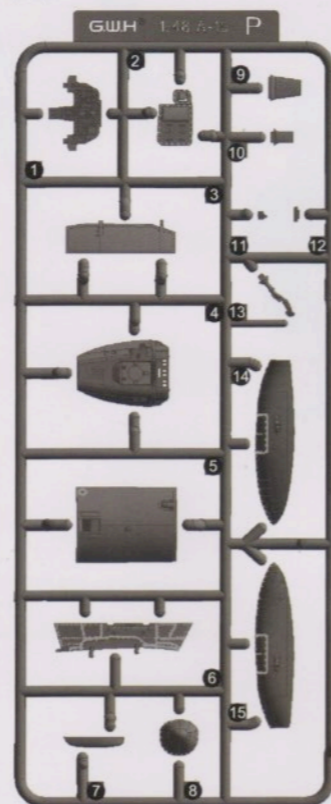

MK83 Part × 1

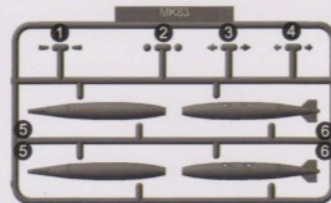

J Part × 1

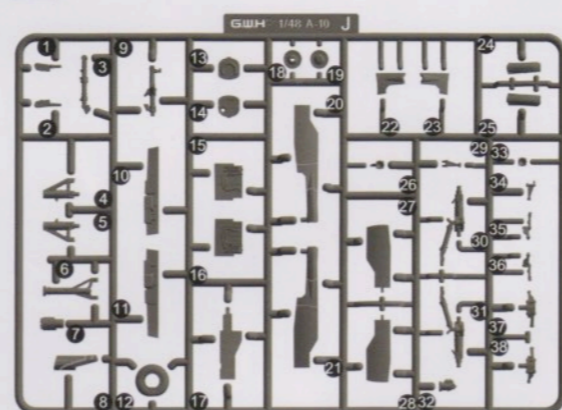

M Part × 2

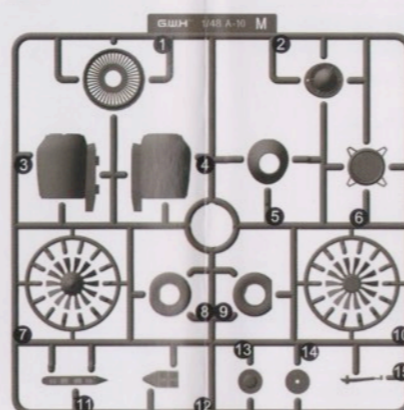

N Part × 1

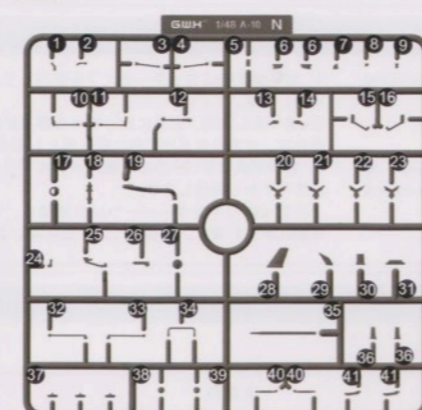

K Part × 1



L Part × 1



MK82 Part × 2



LAU-131 Part × 2

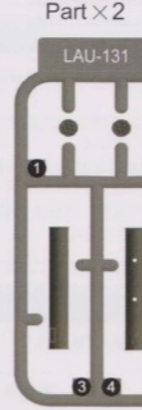

BRU-42 Part × 2



Q Part × 1

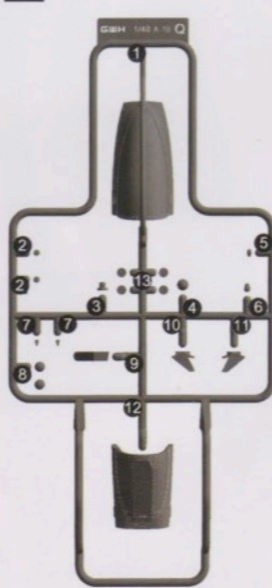

R Part × 1

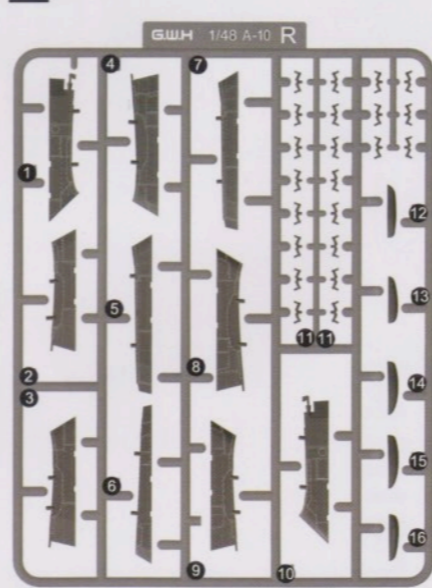

AGM-65 Part × 2

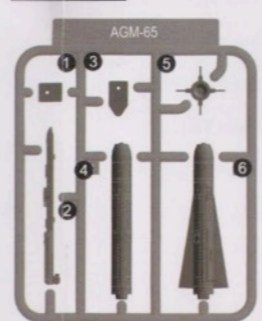

ALQ-131 Part × 1

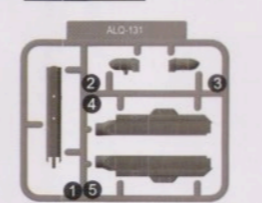

S Part × 1



AIM-9L Part × 2

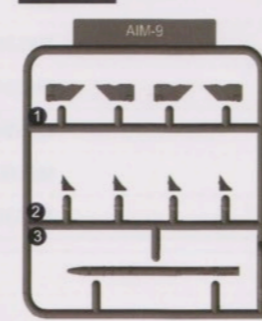

AN/ALQ-184 Part × 1

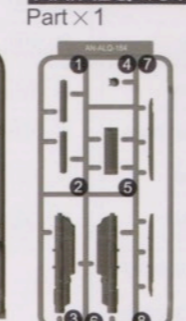

PE

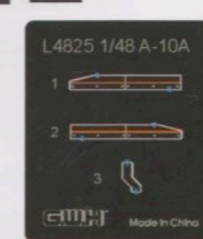

SPECIAL WEIGHT

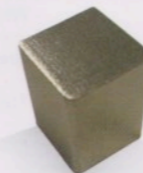

Decal A

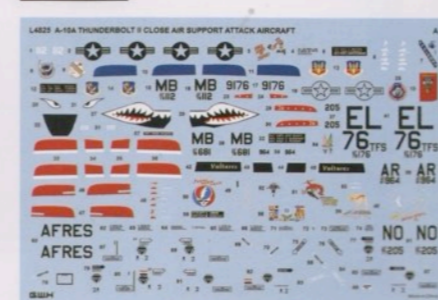

Decal B

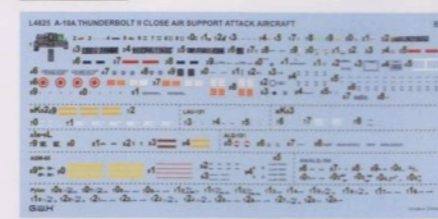

阴影零件不使用
DO NOT USE THE
SHADOW PARTS

3

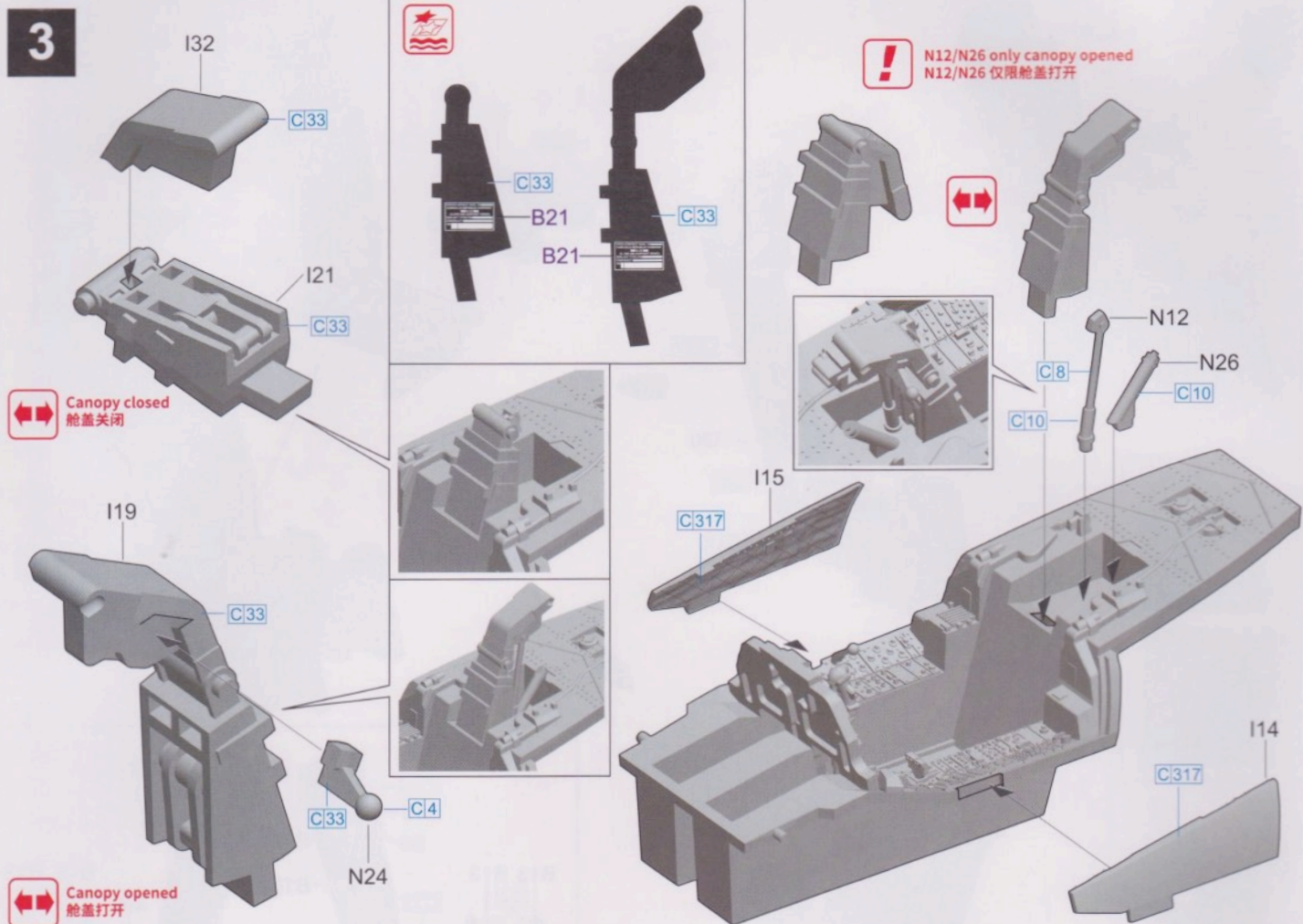

4

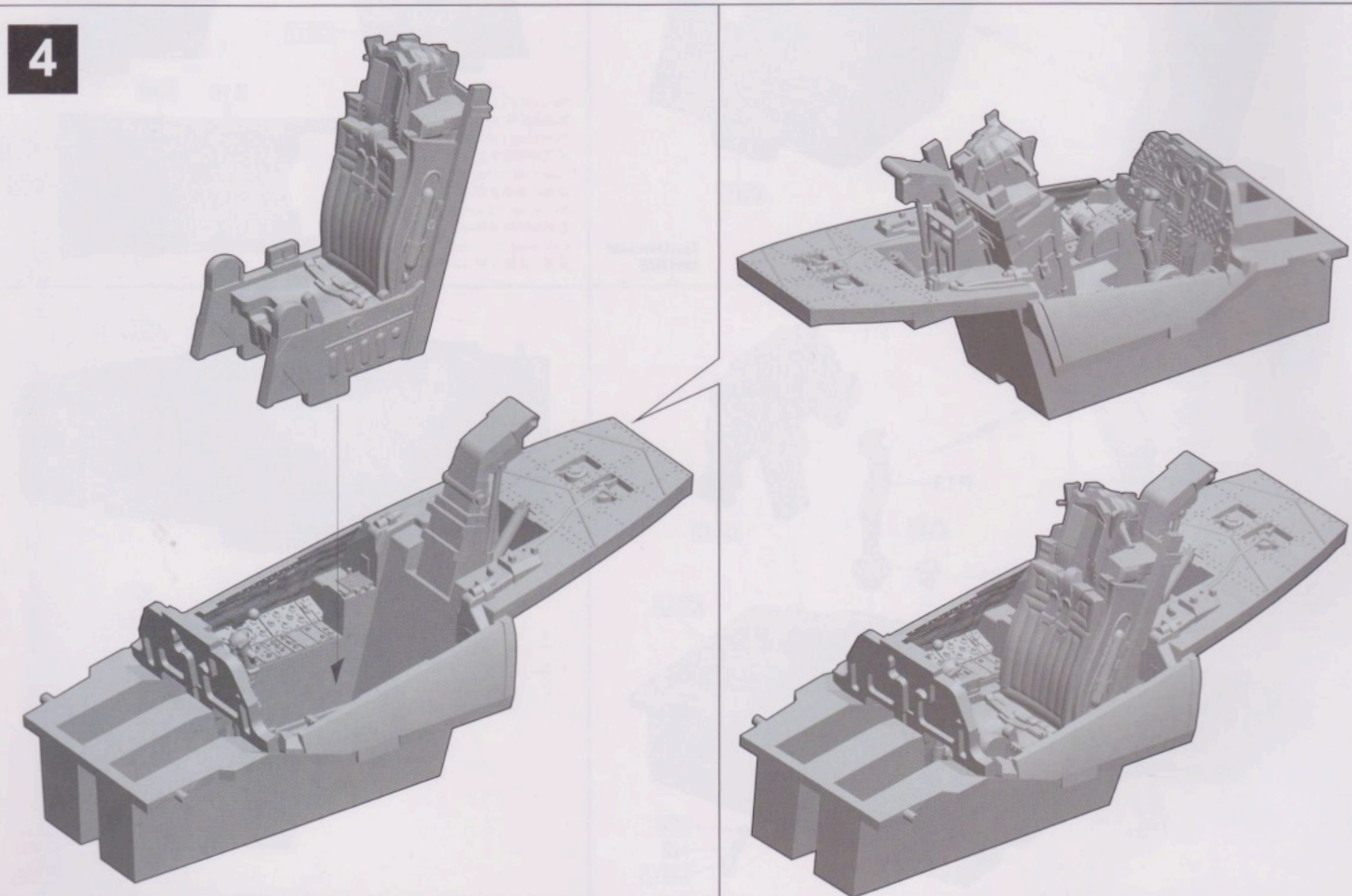

5

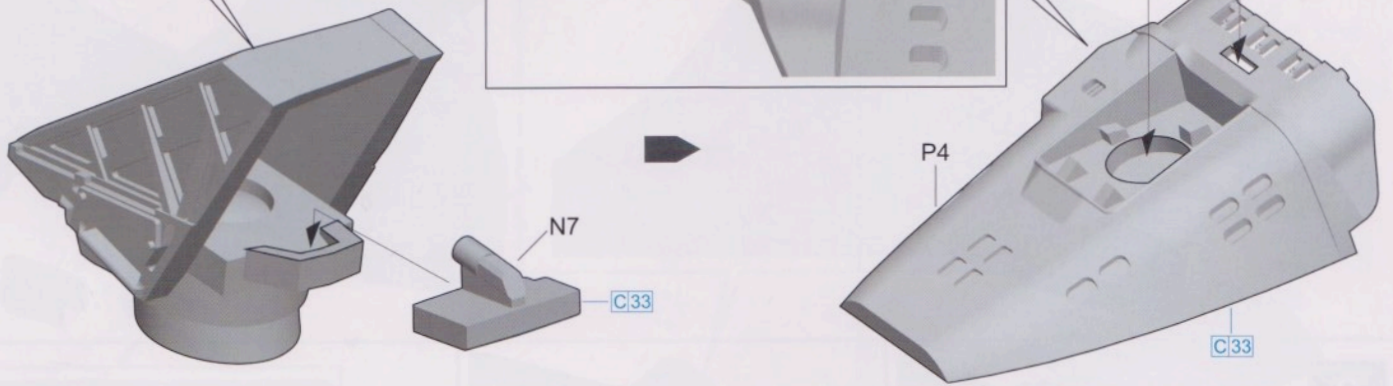
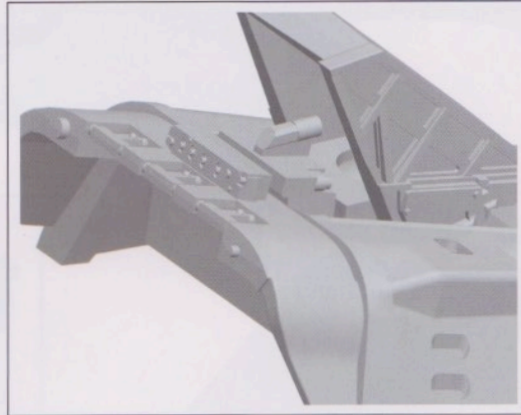
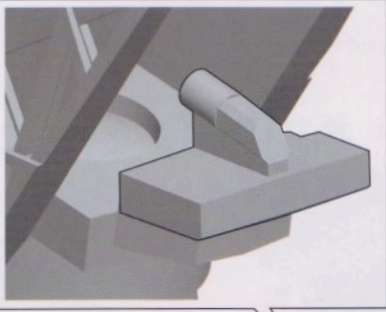
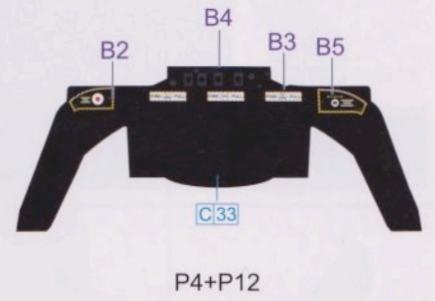
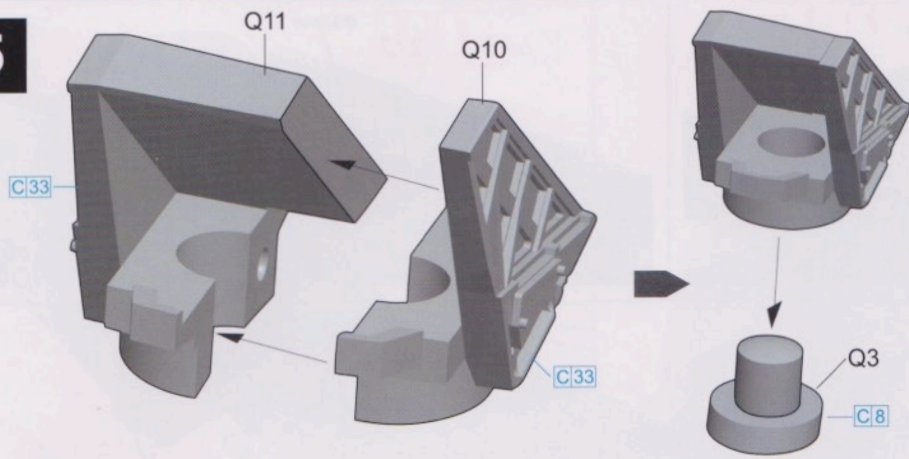

6

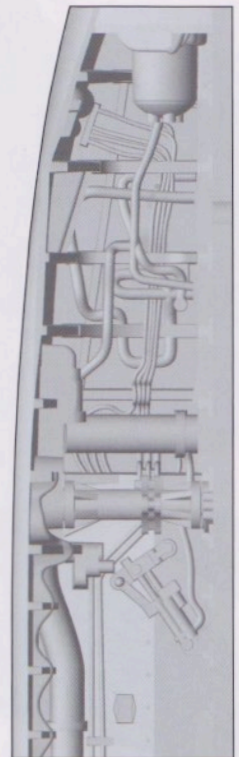
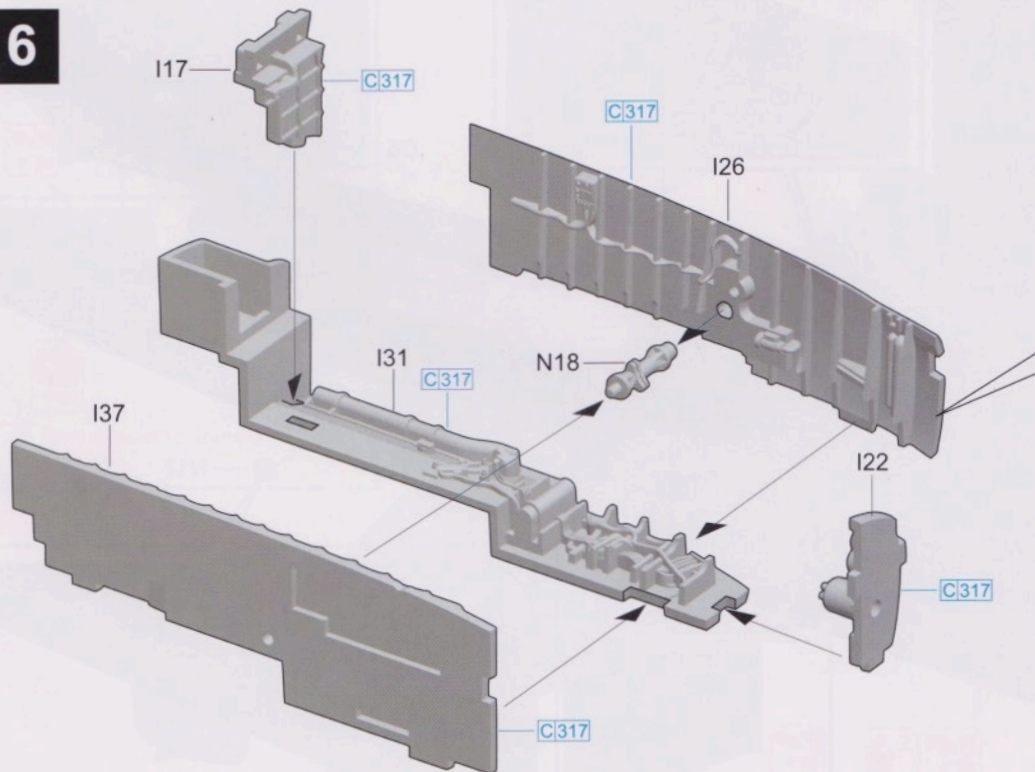

7

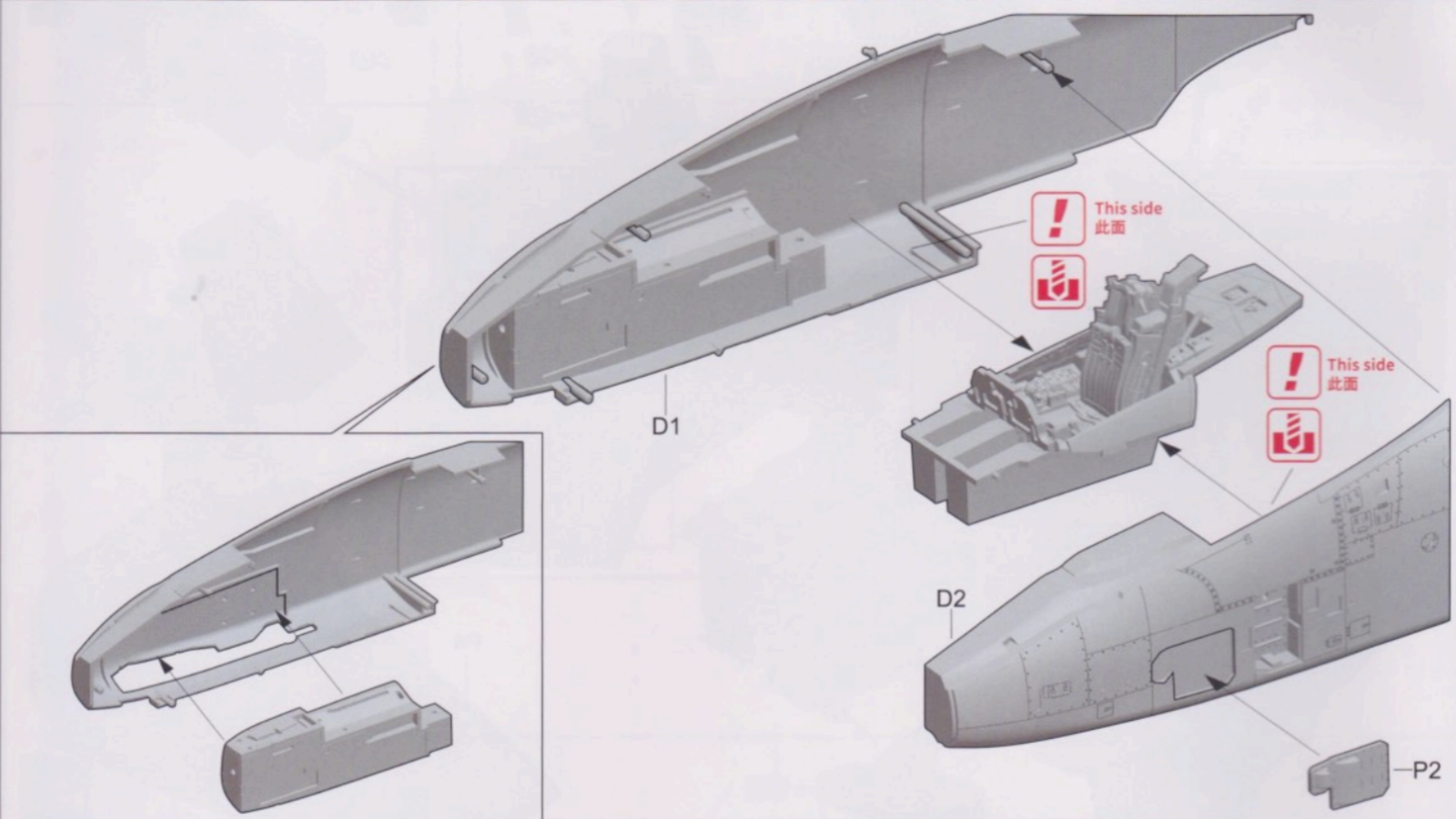
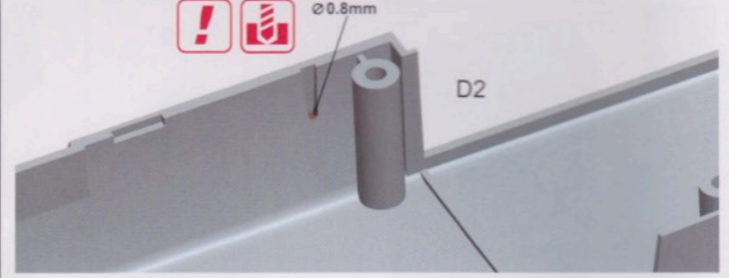
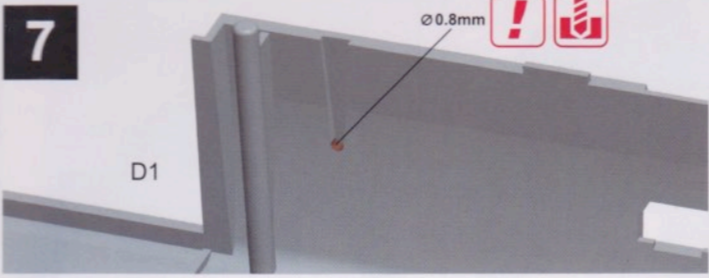

8

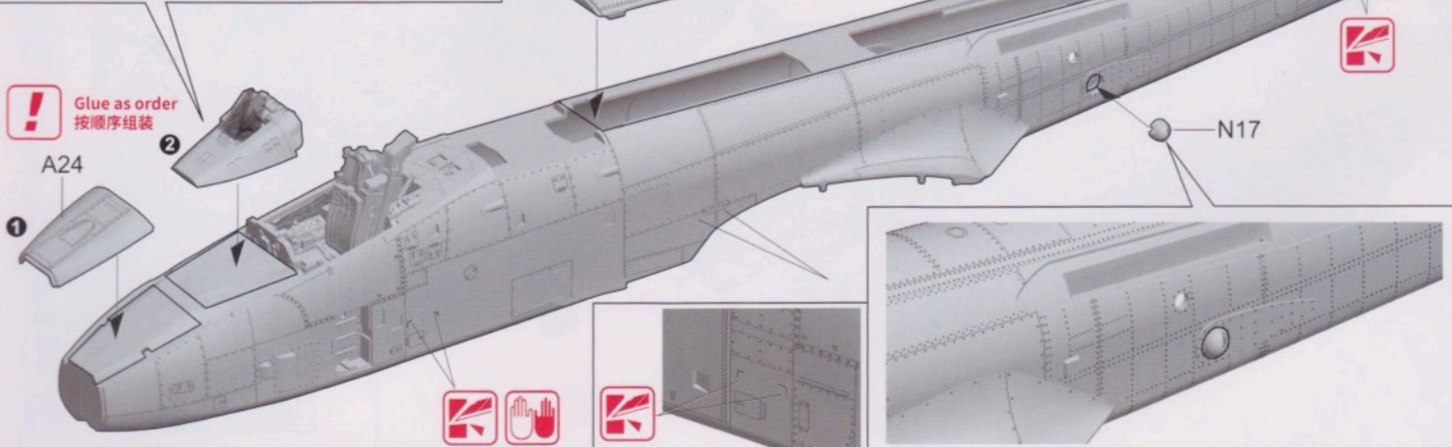
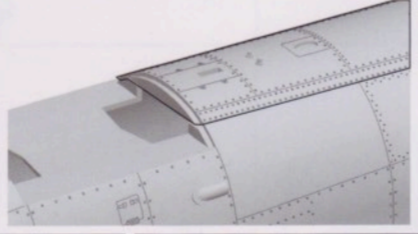
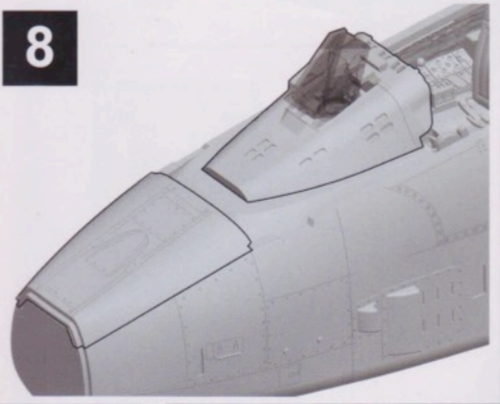

9

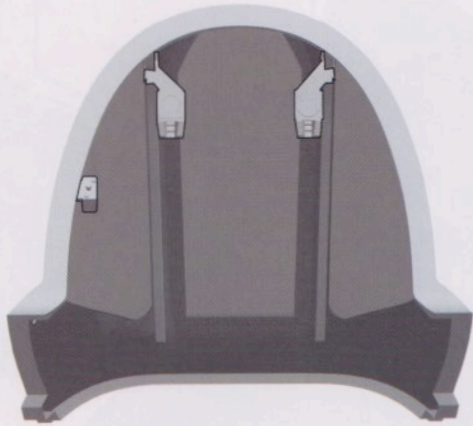

10

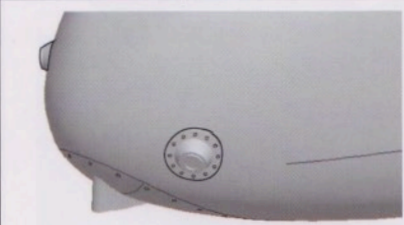
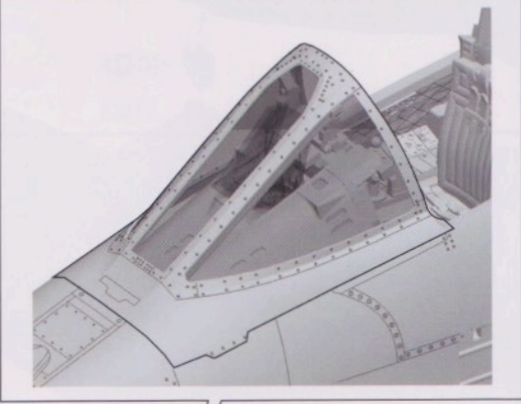
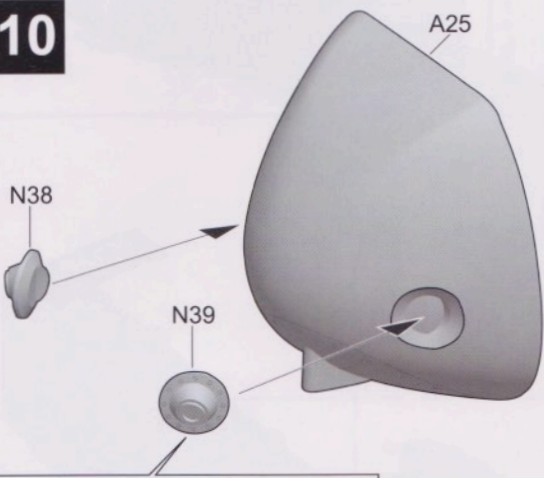

! Only for painting scheme B
仅限涂装B

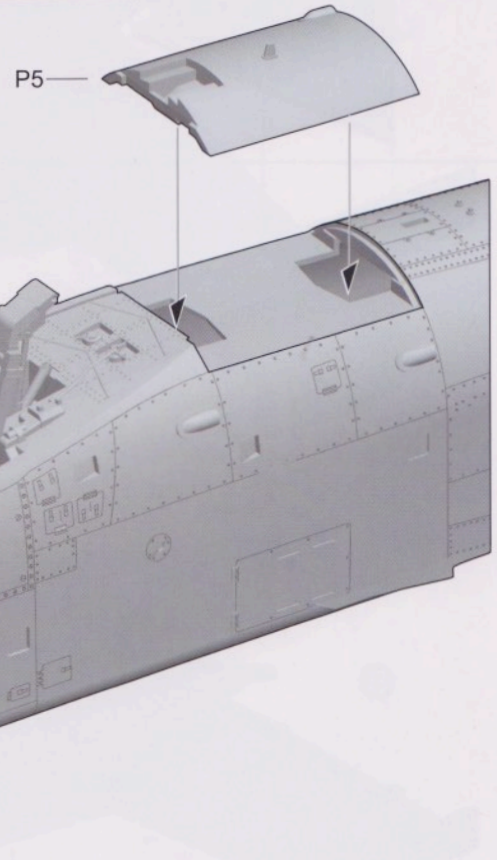

11

! Glue as order
按顺序组装

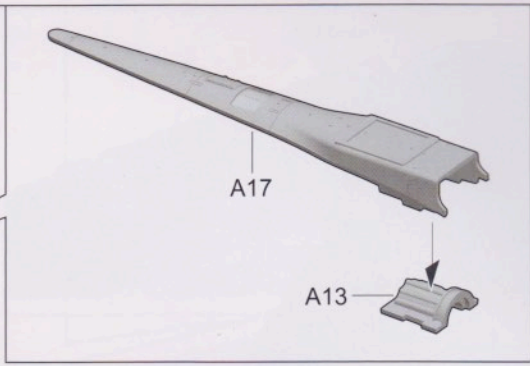

12

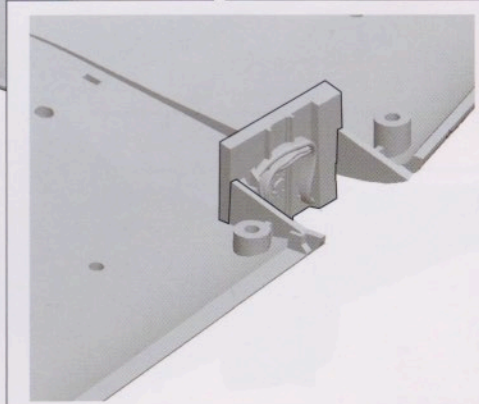
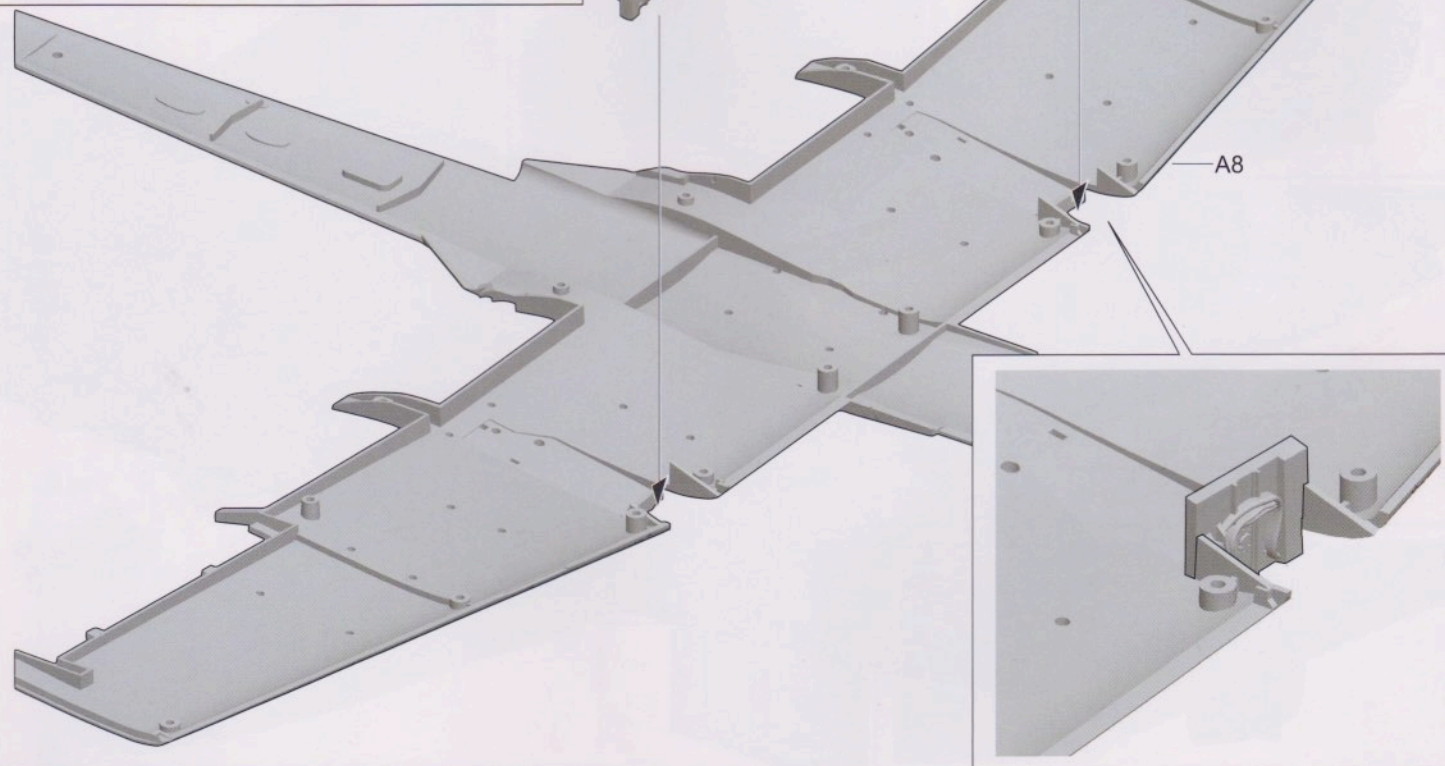
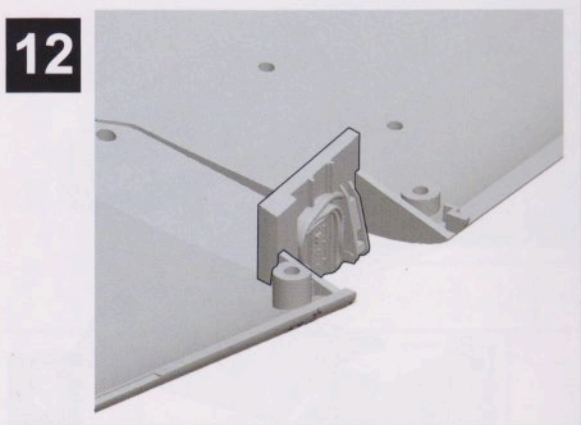

13

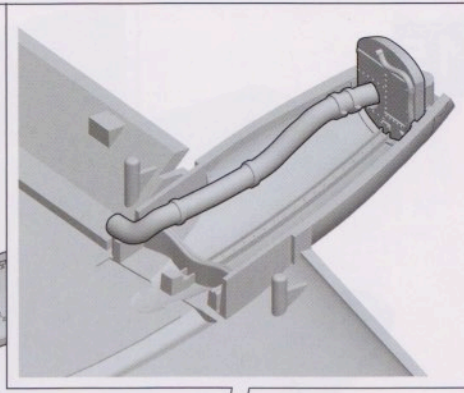

! Glue as order
按顺序组装

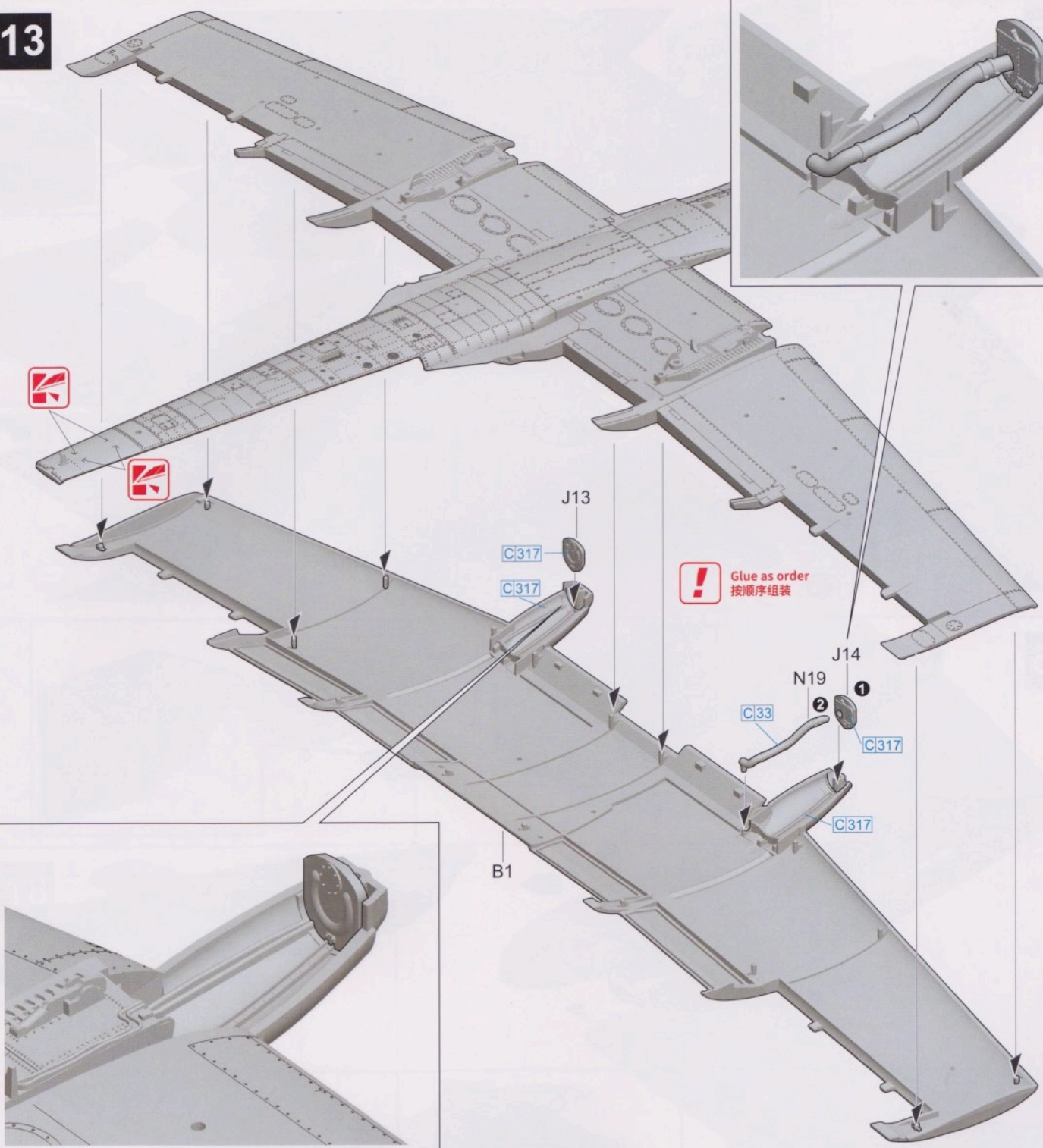

14

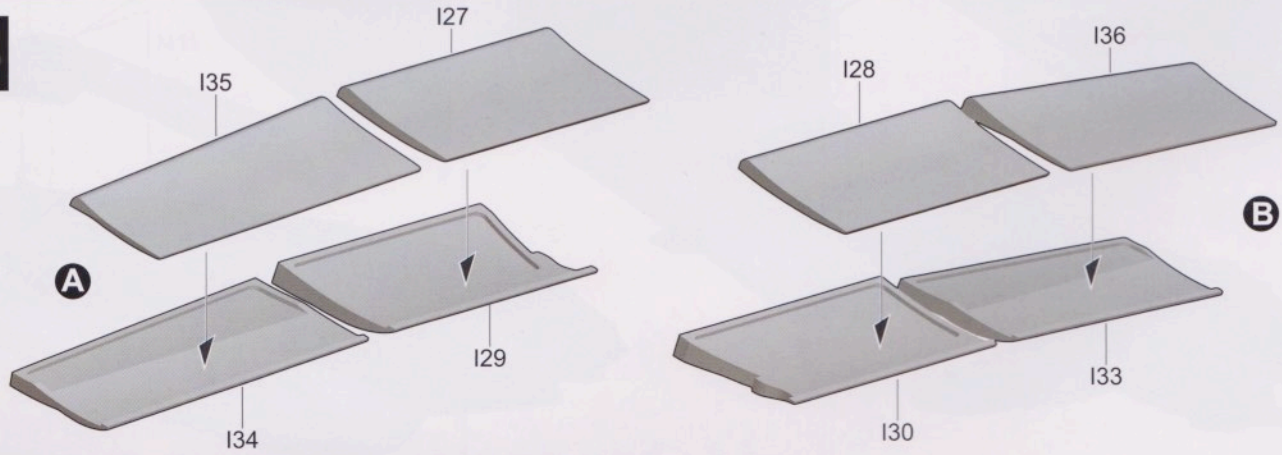

15

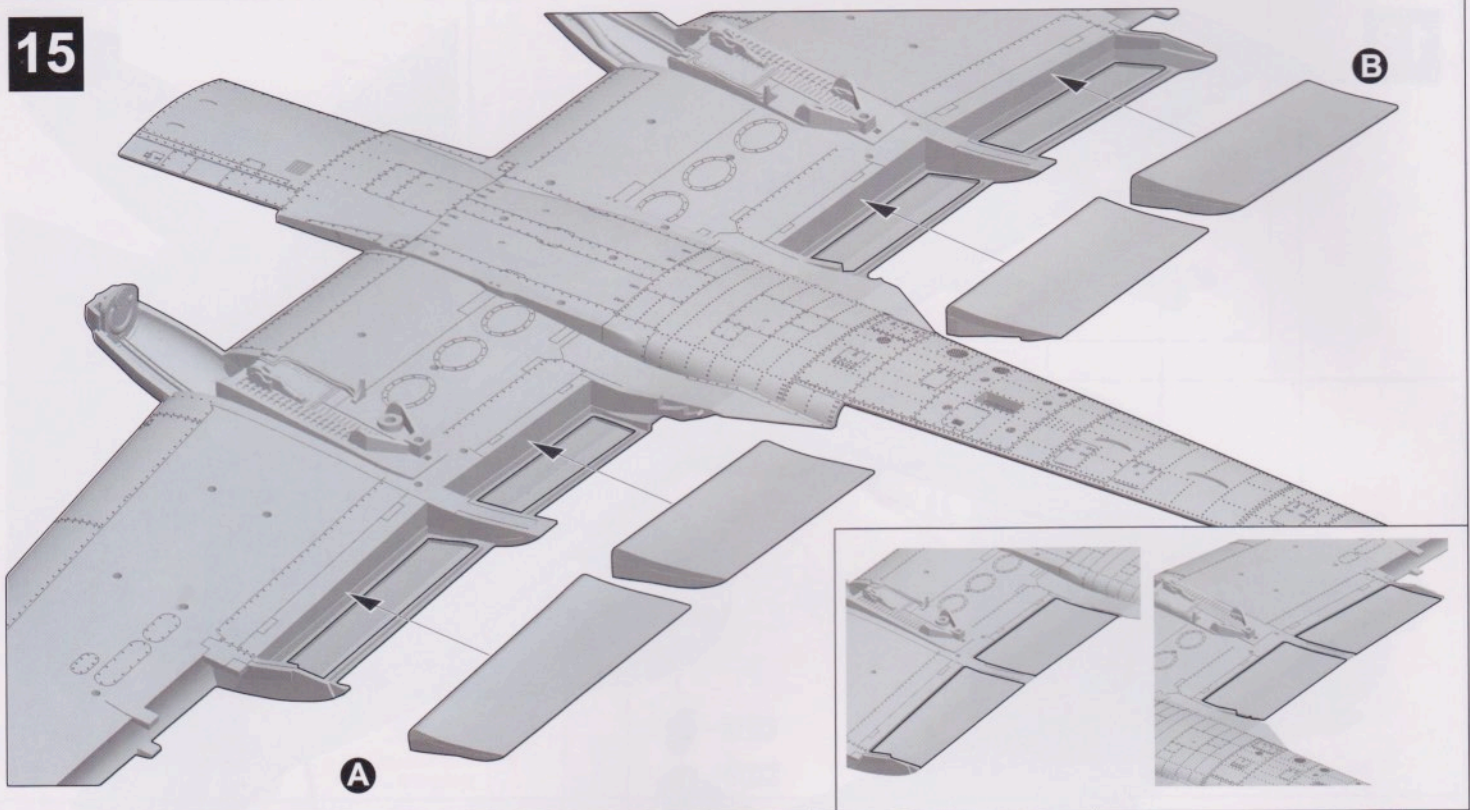

16

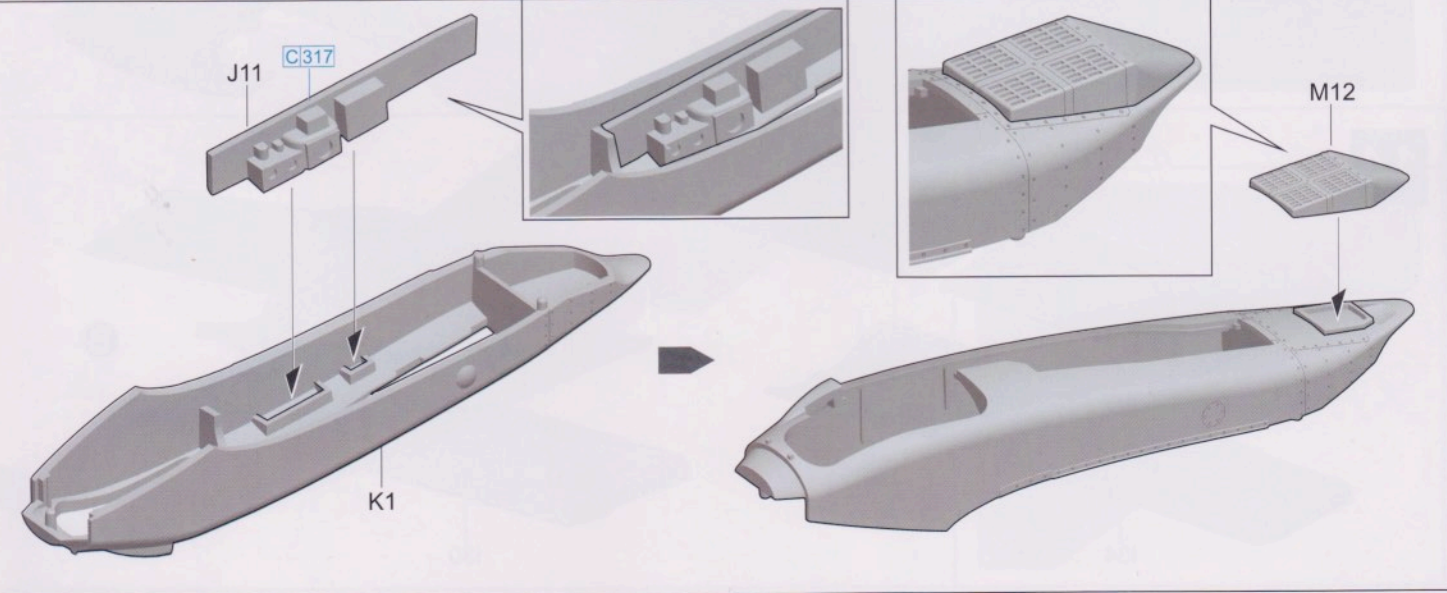
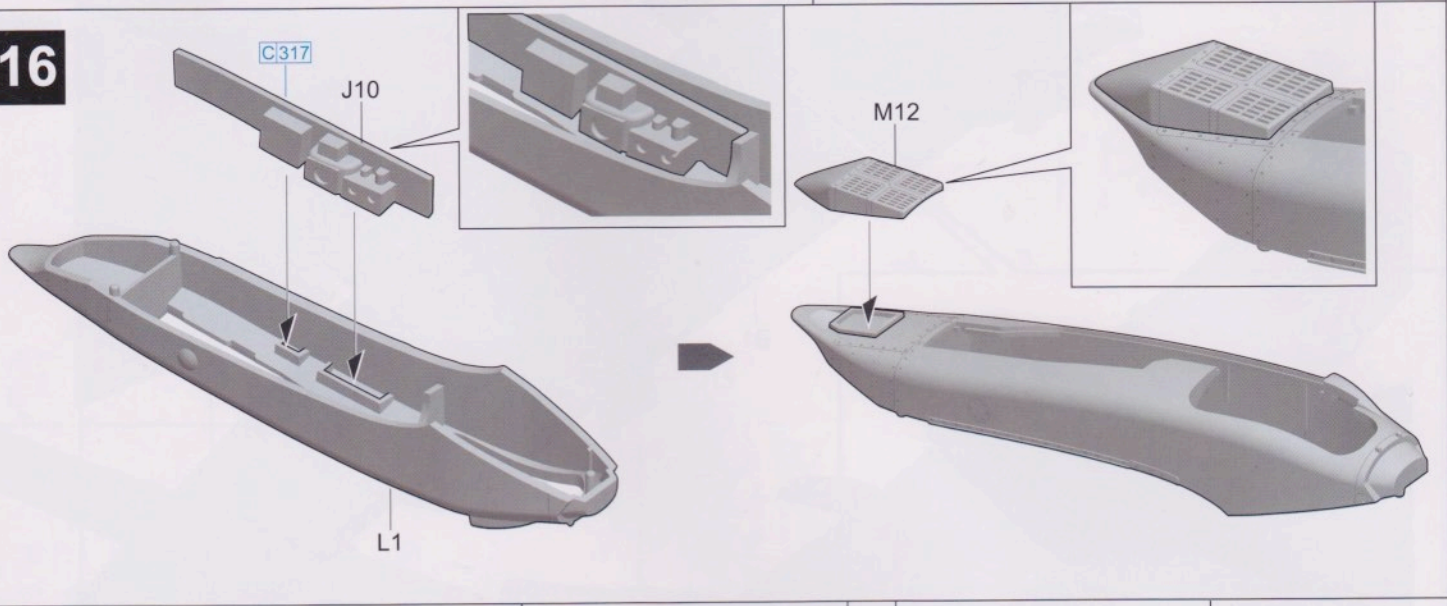

17

N16
MC218
C317

! Glue as order
按顺序组装

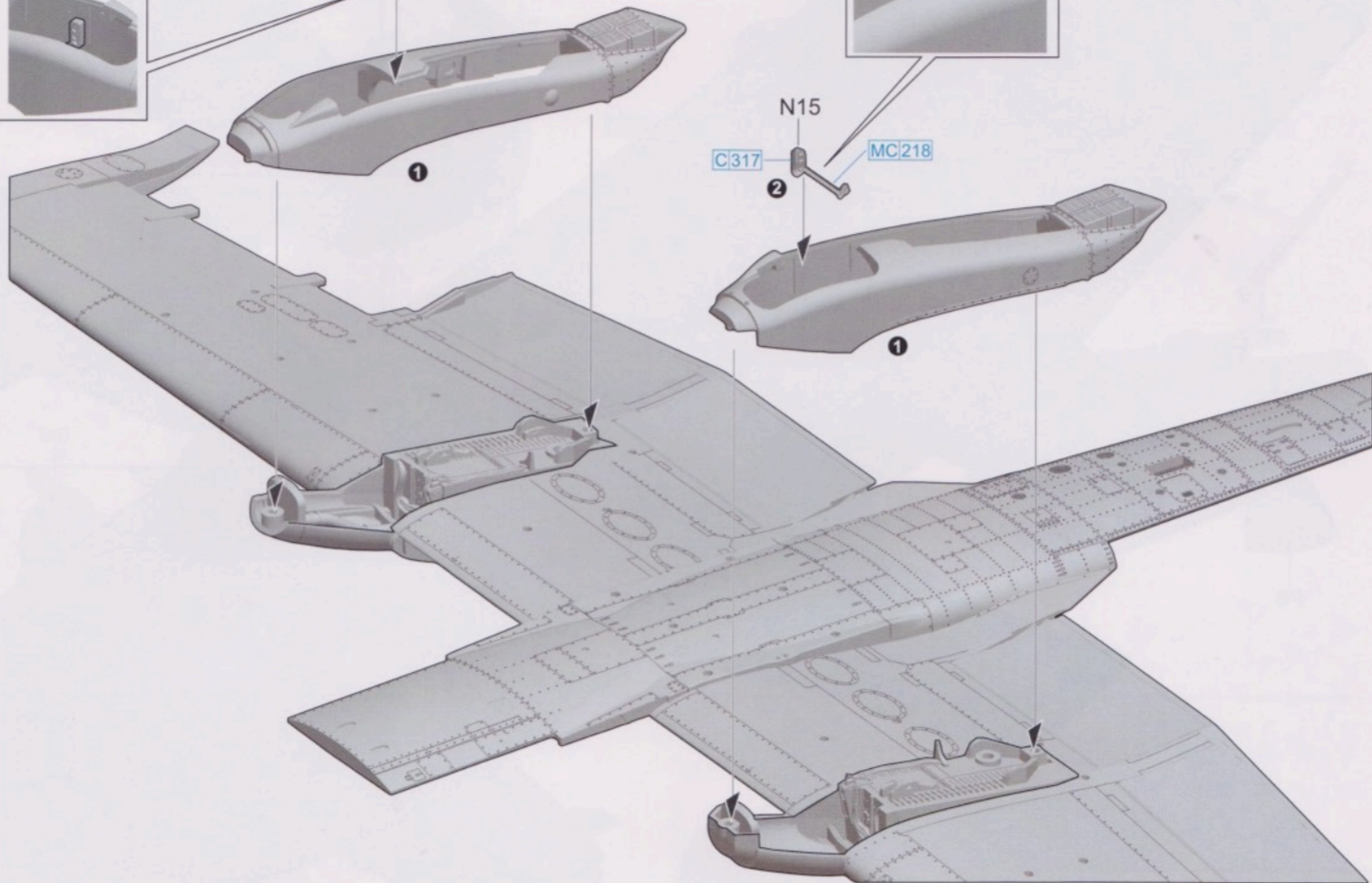
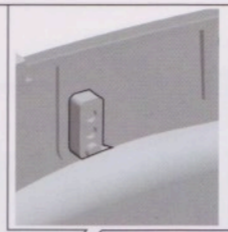

18

B

M11

P15

M11

A

P14

A

B

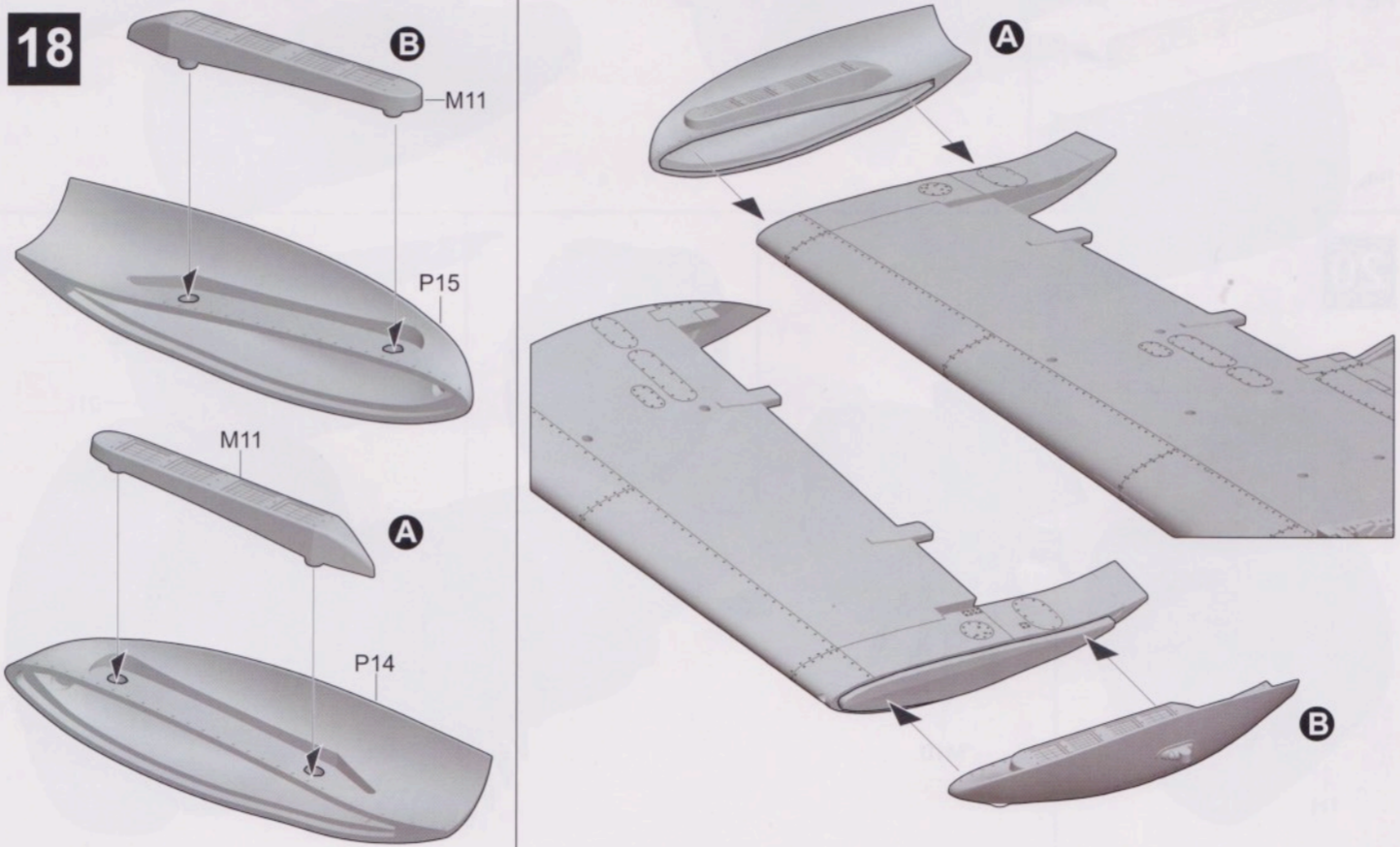

19

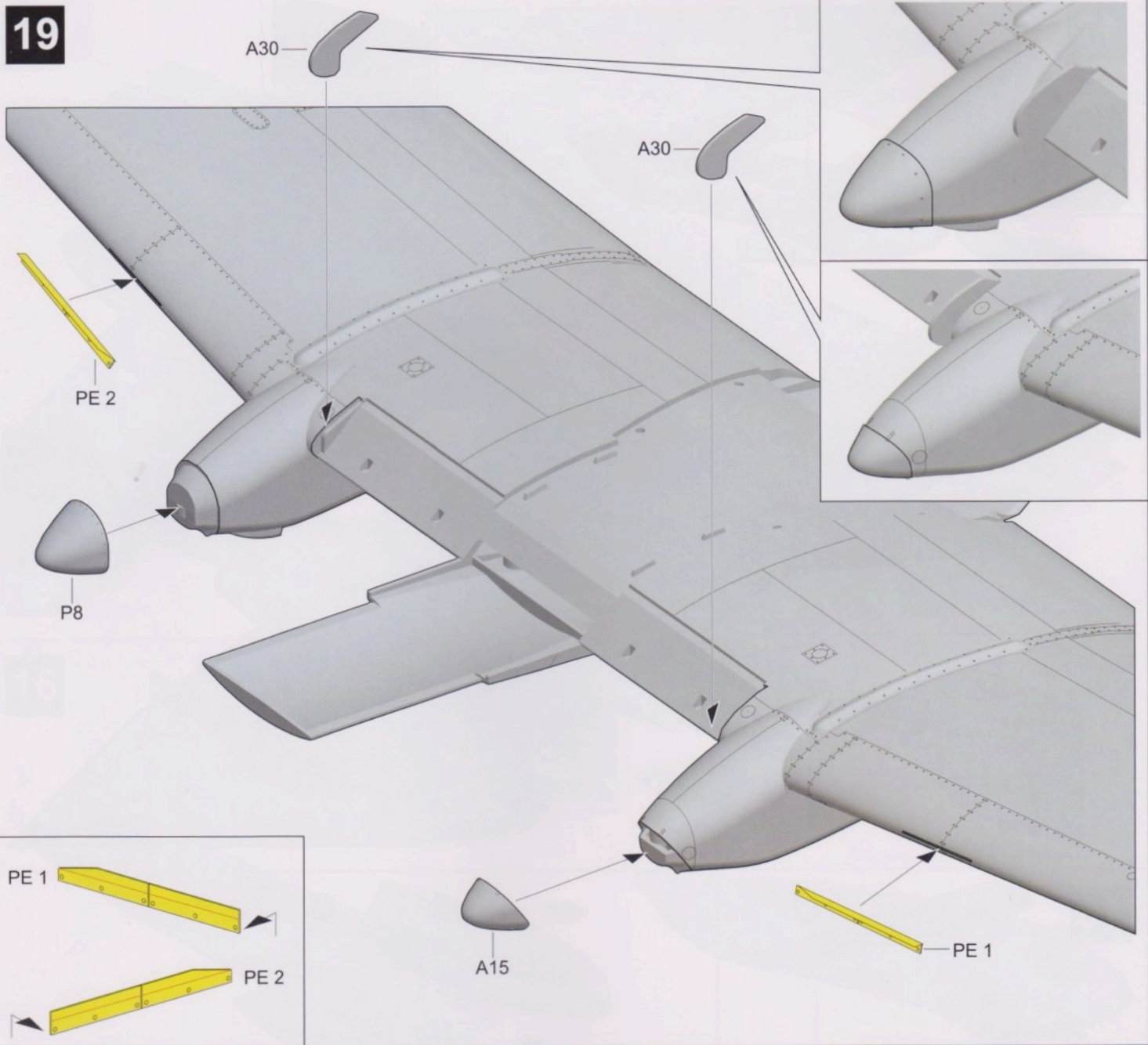

20

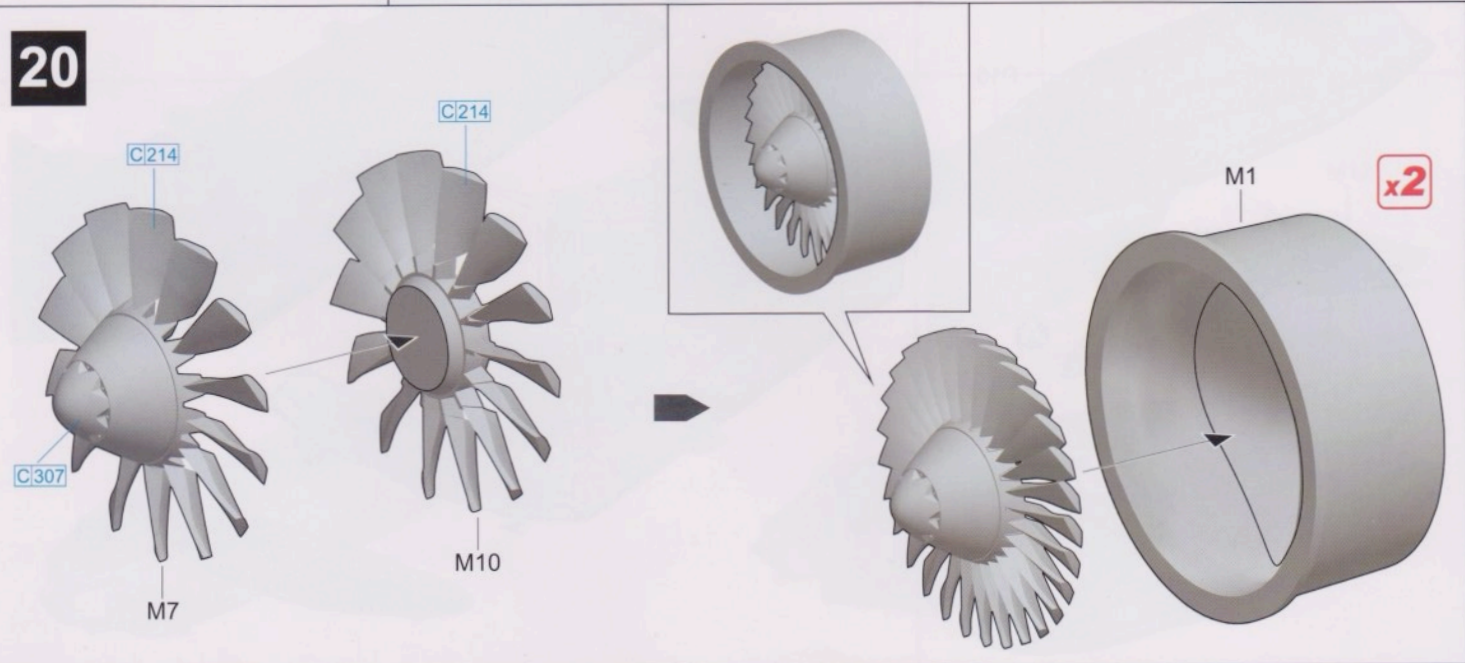

20

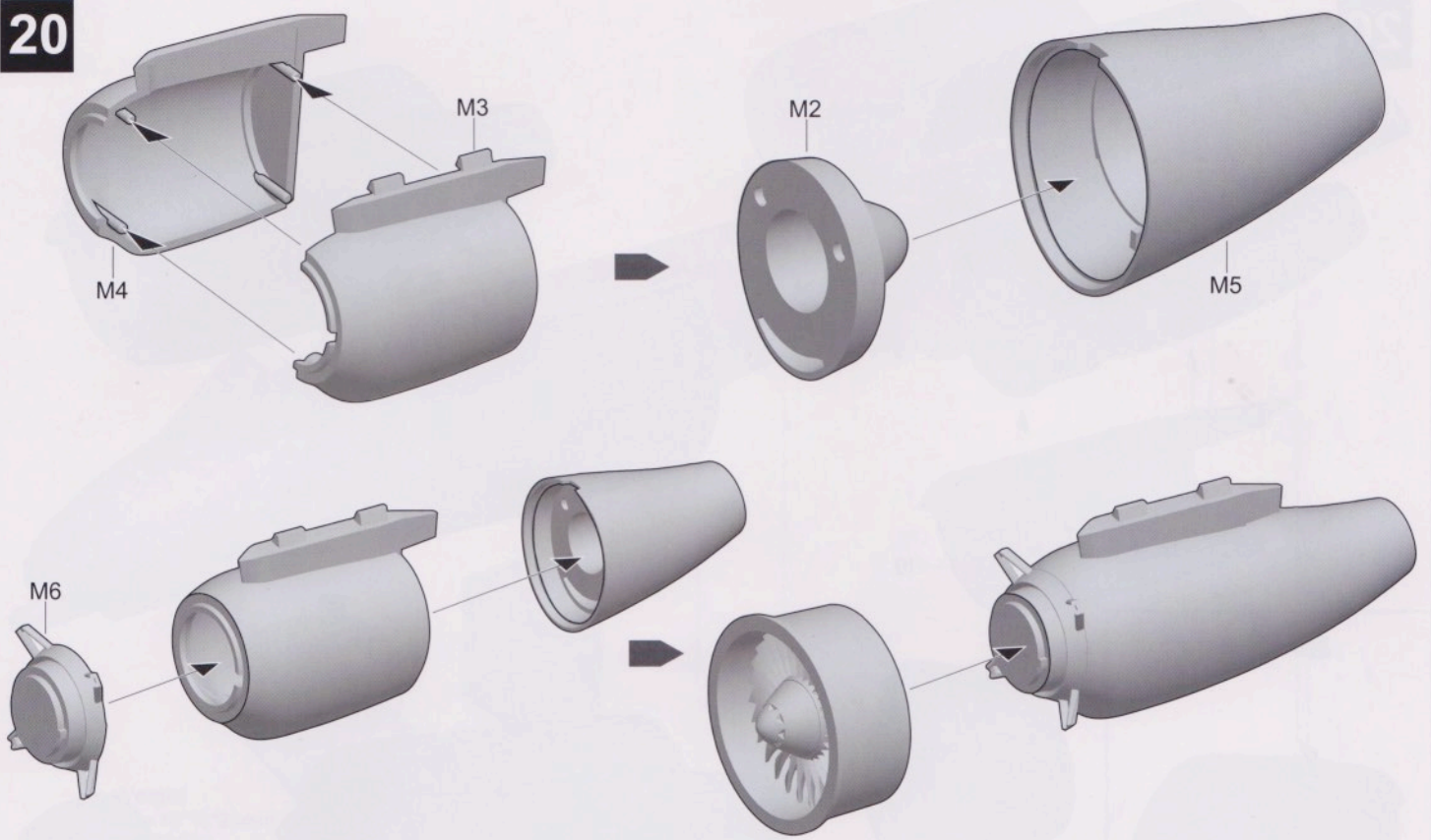

20

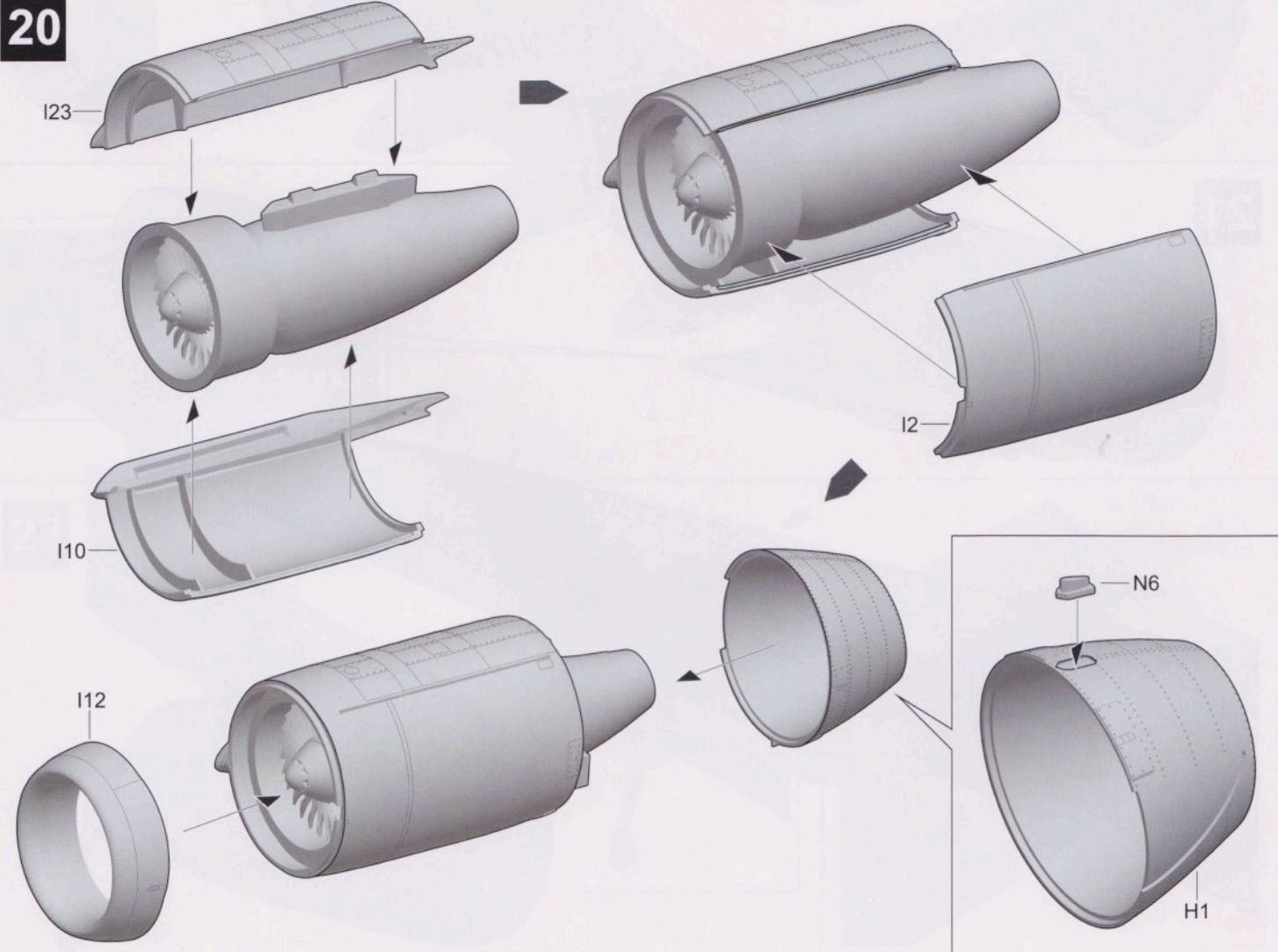

20

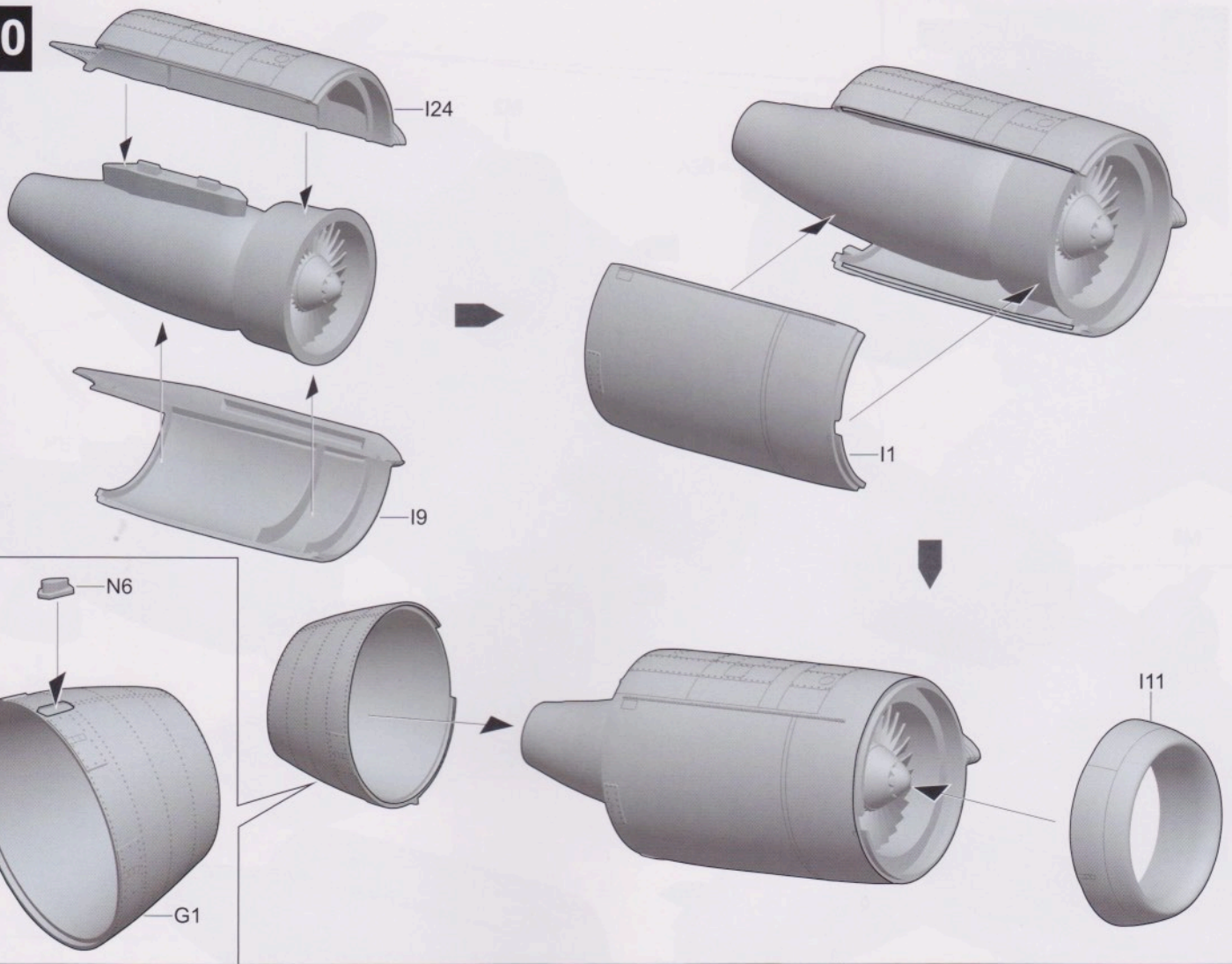

21

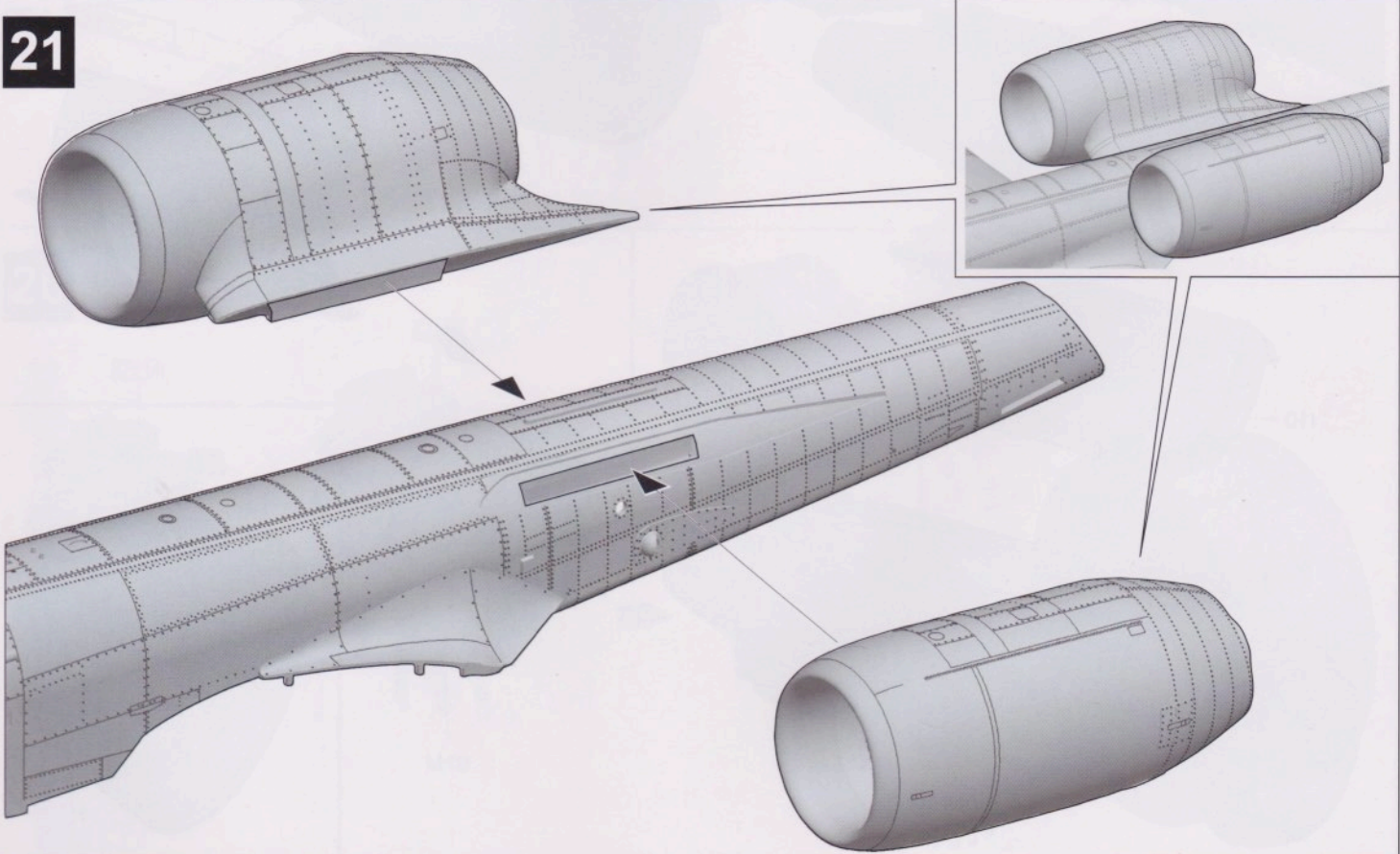

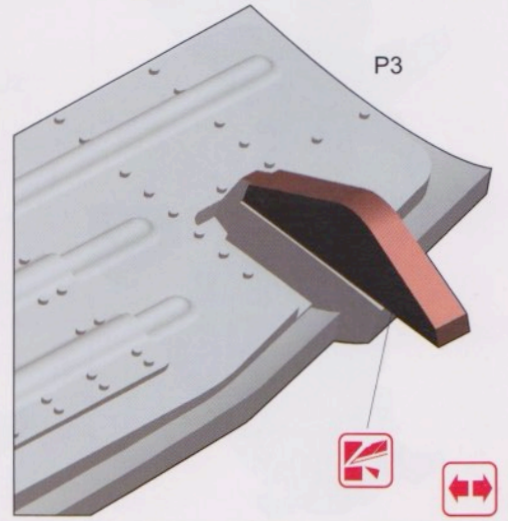
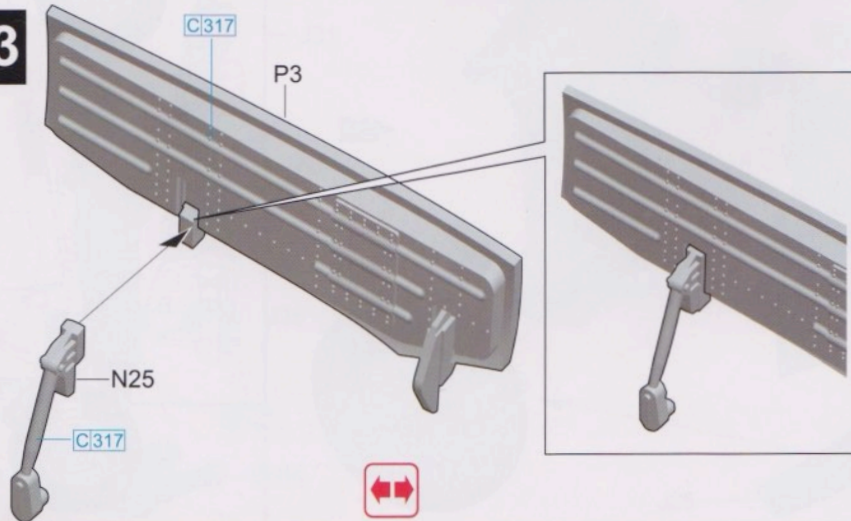
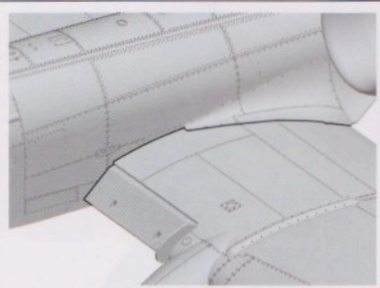
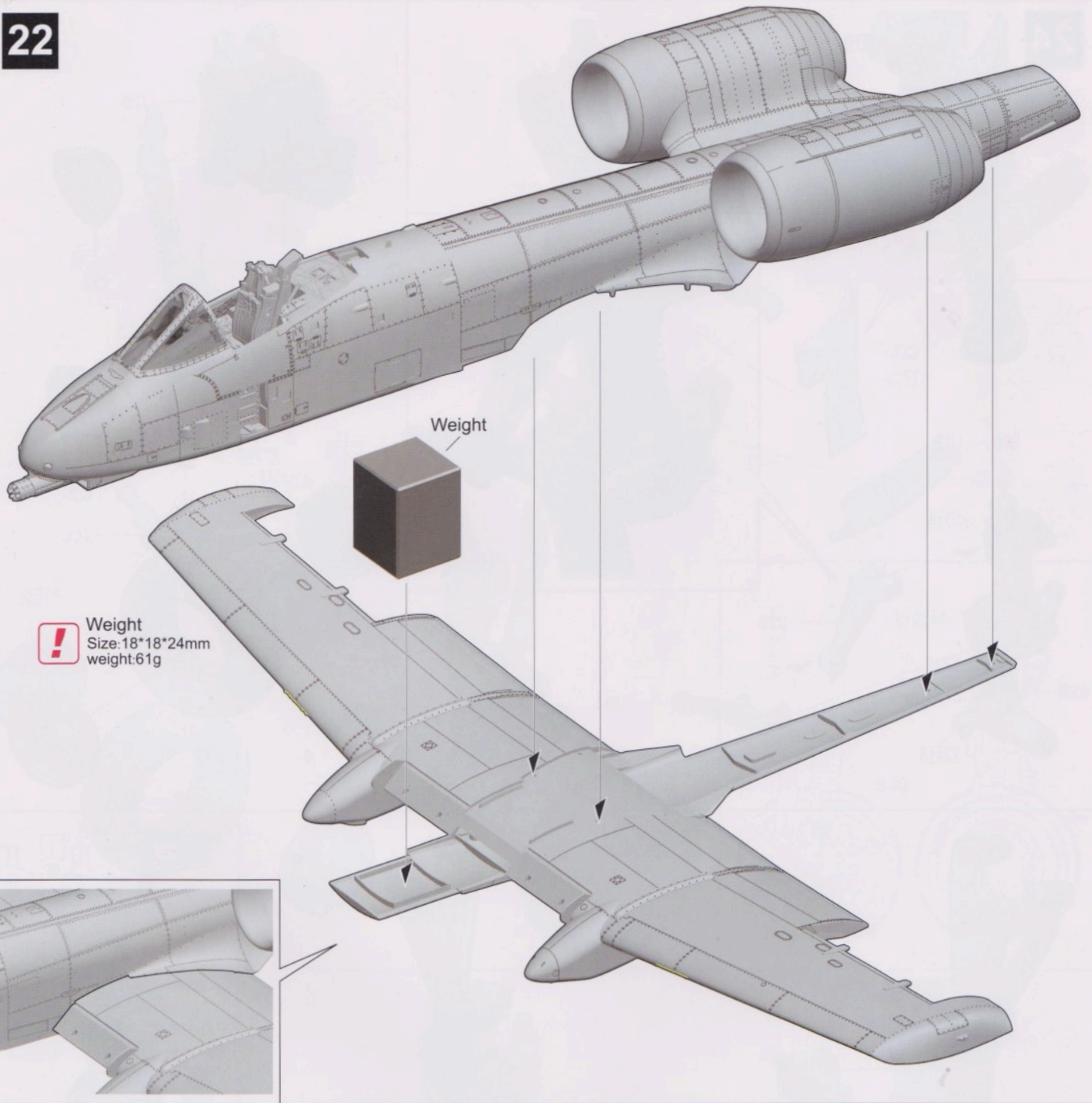

24

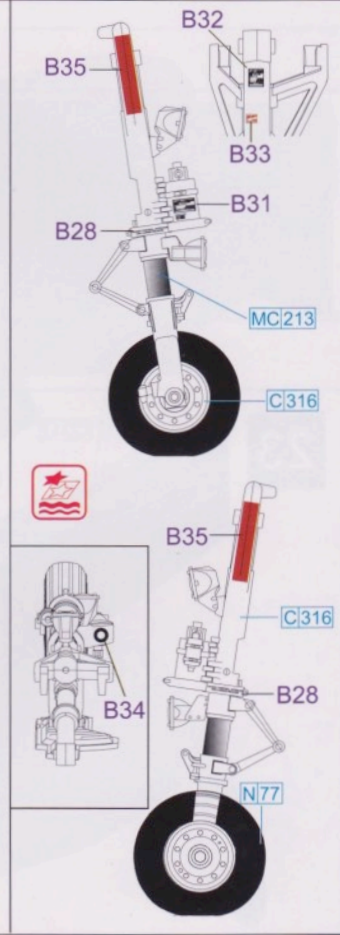
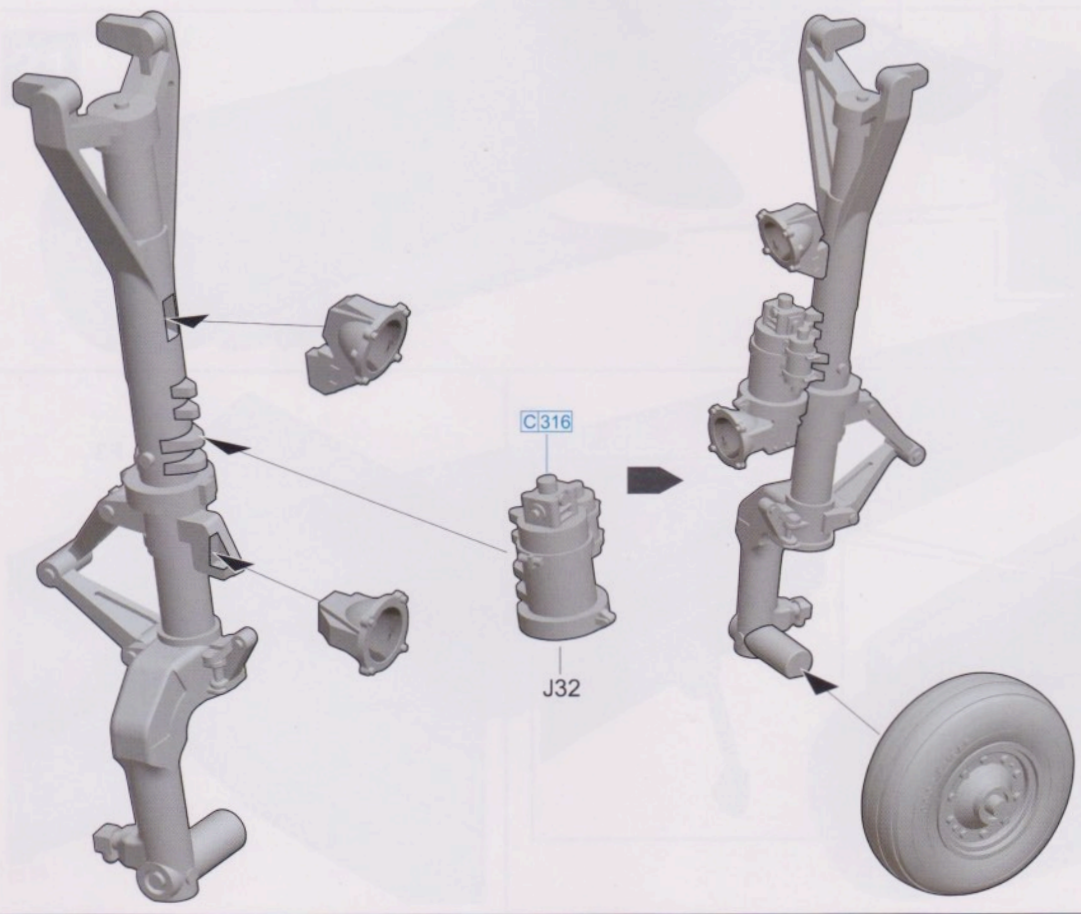
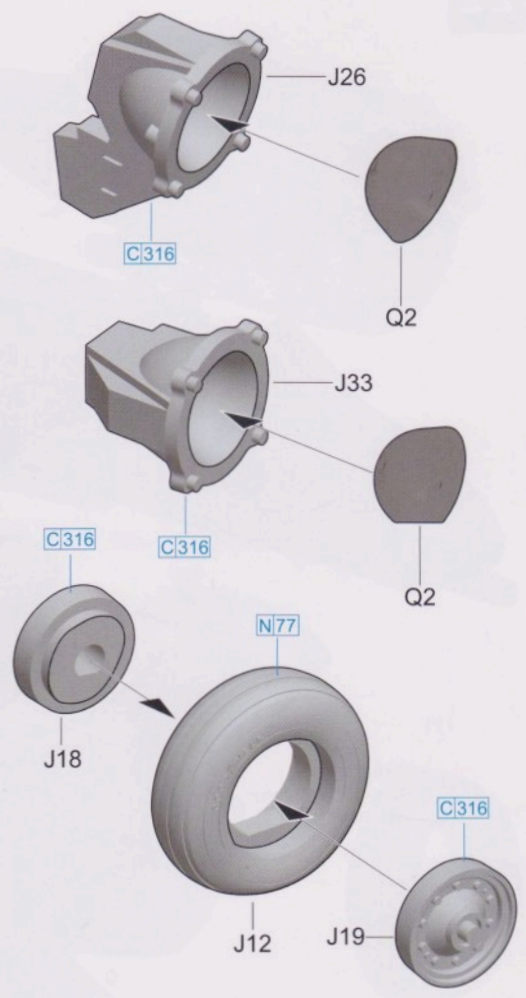
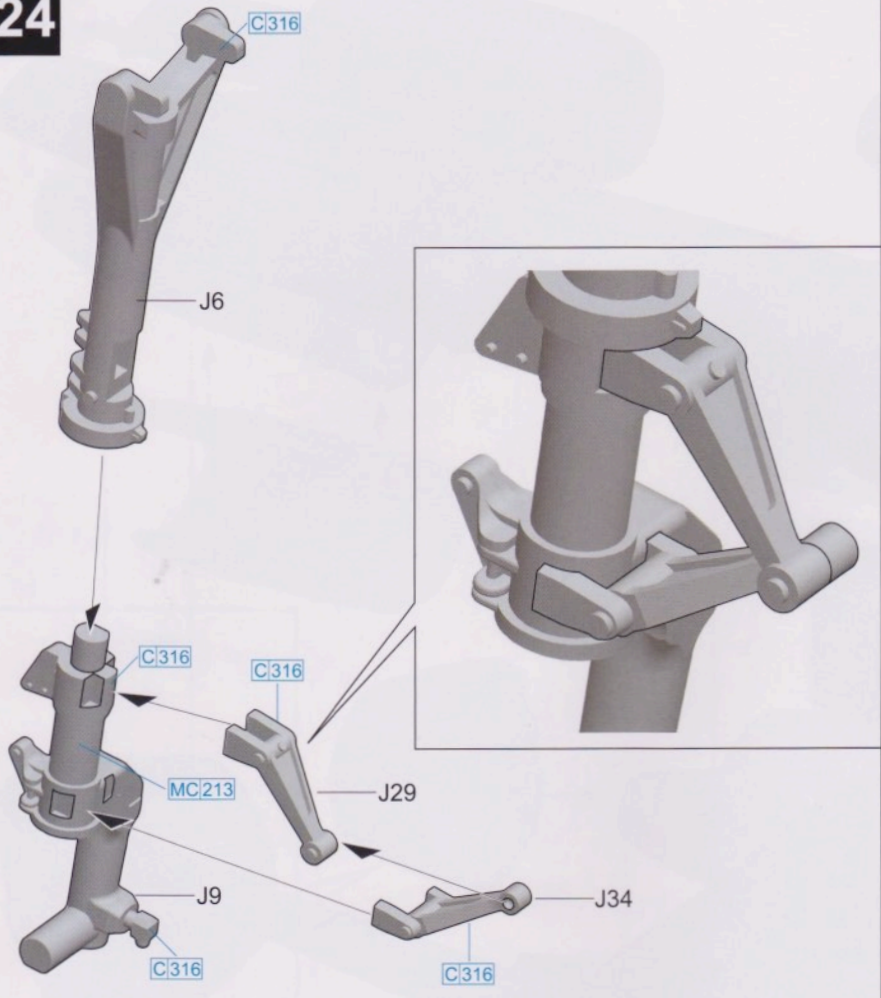

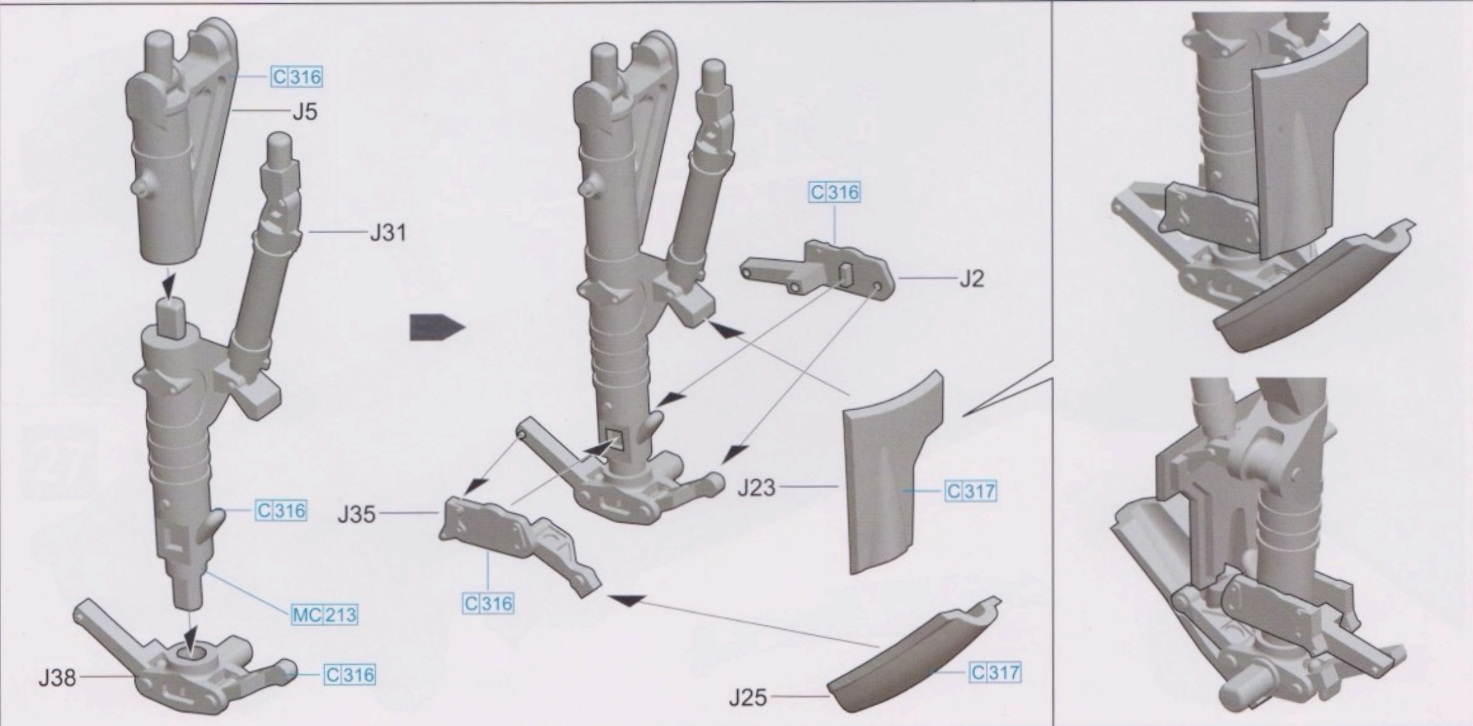
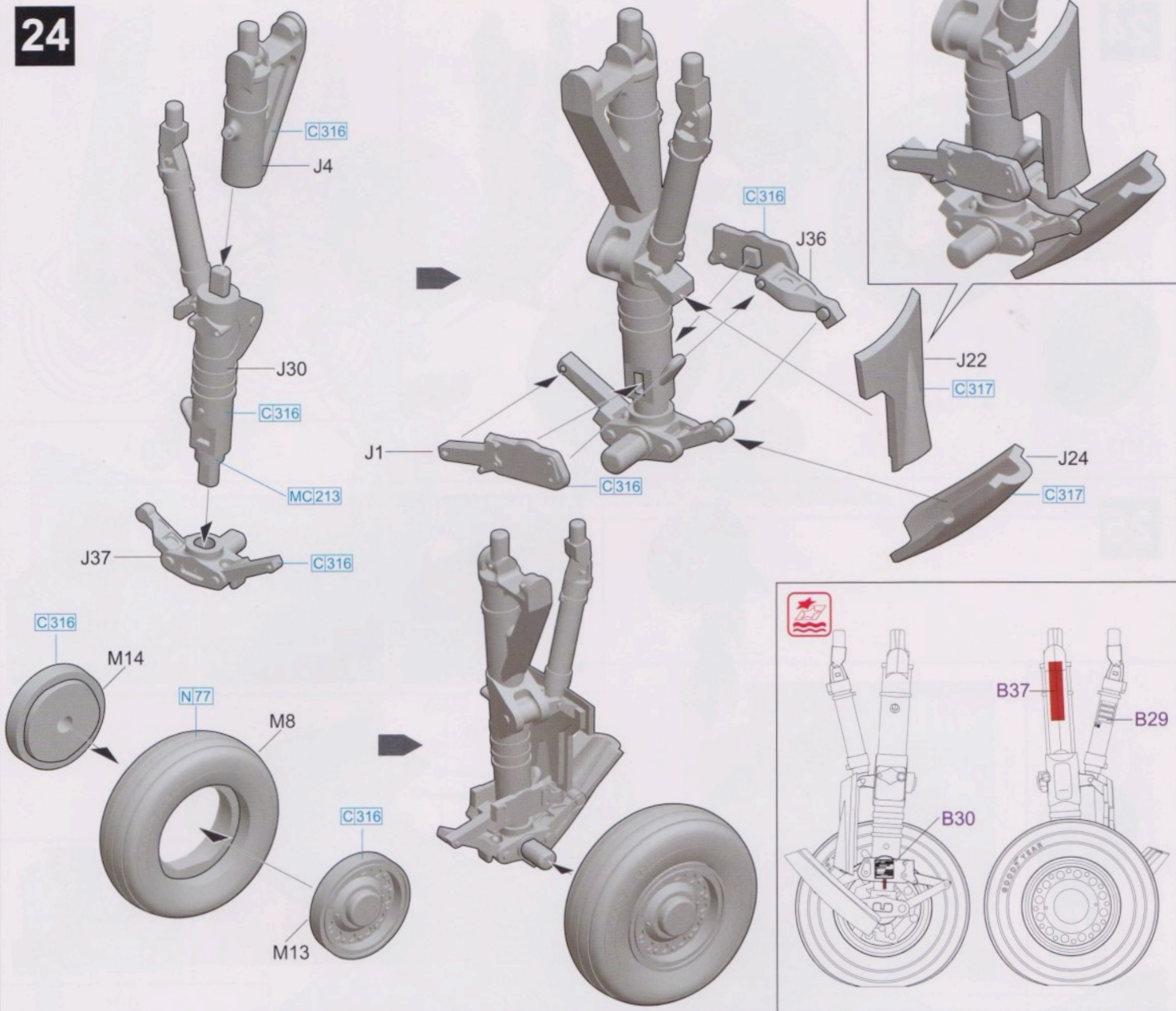

24

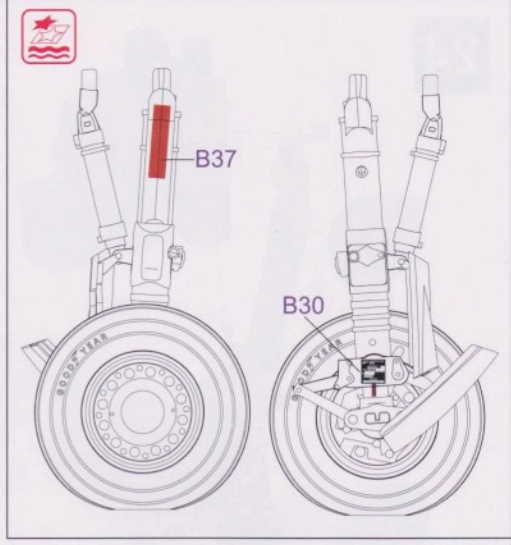
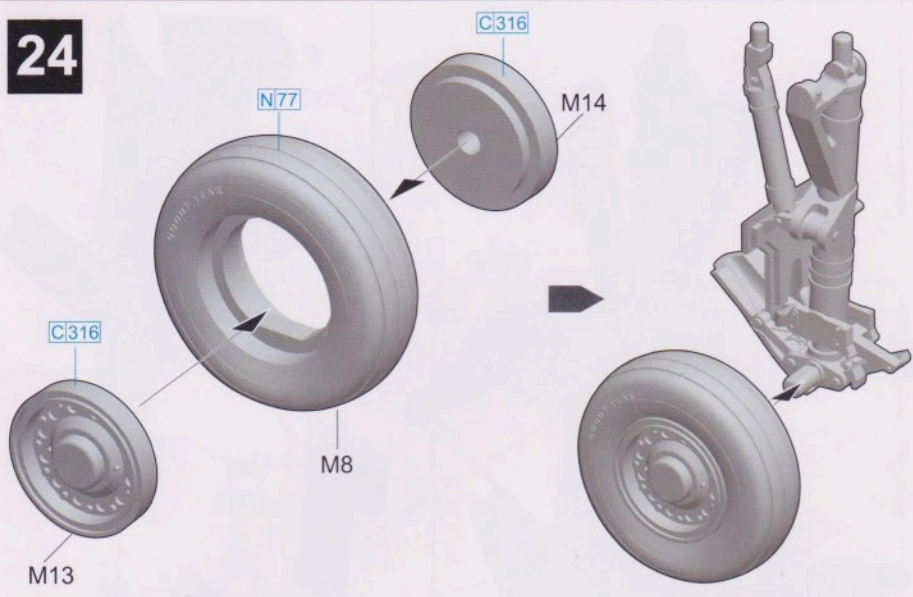

25

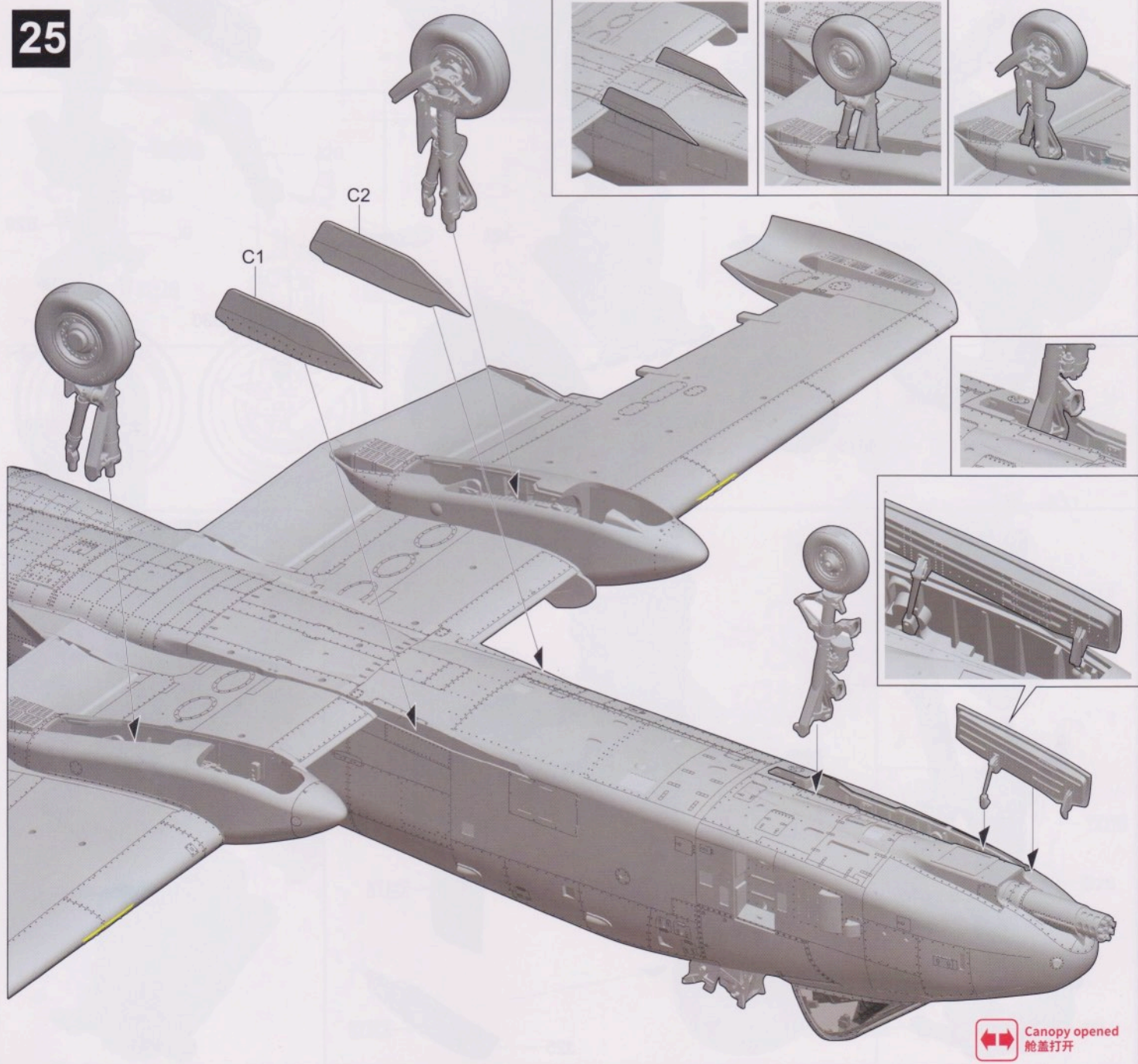

Canopy opened
舱盖打开

26

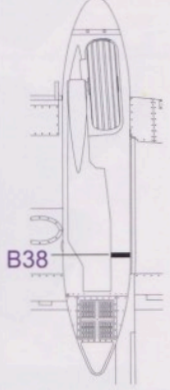
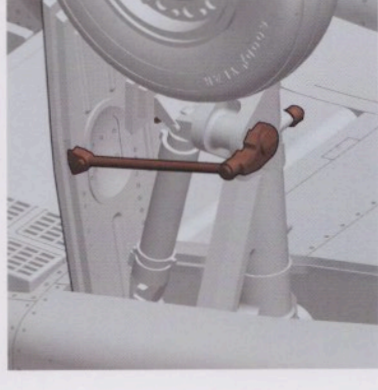
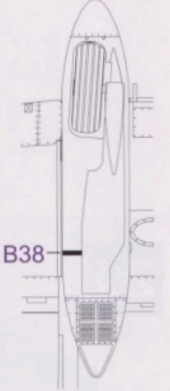
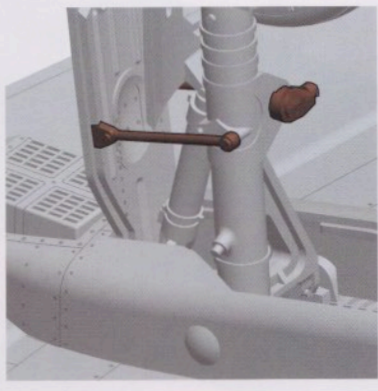
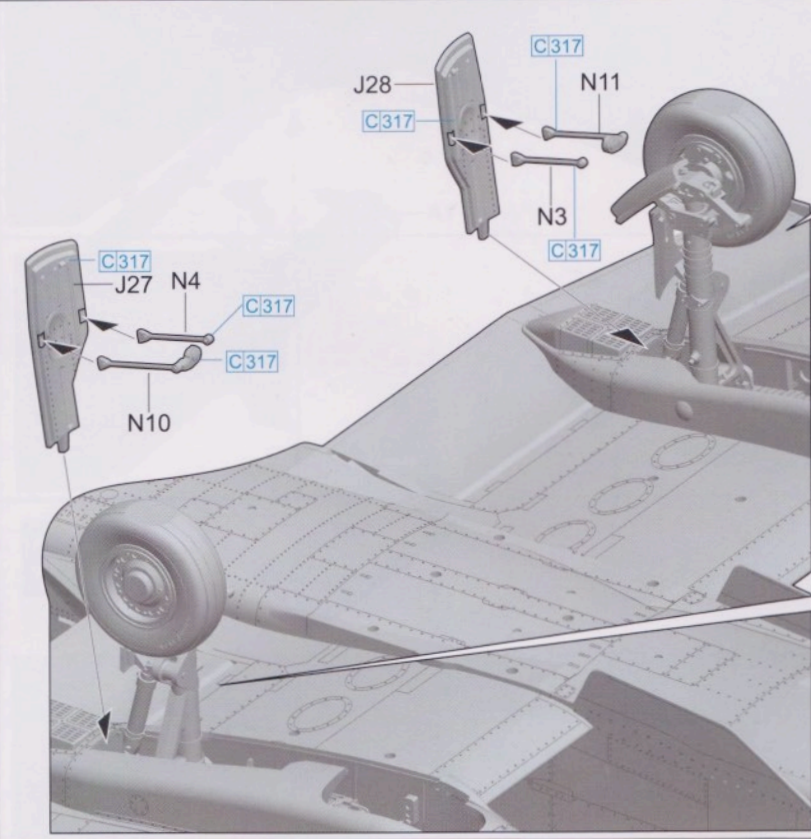
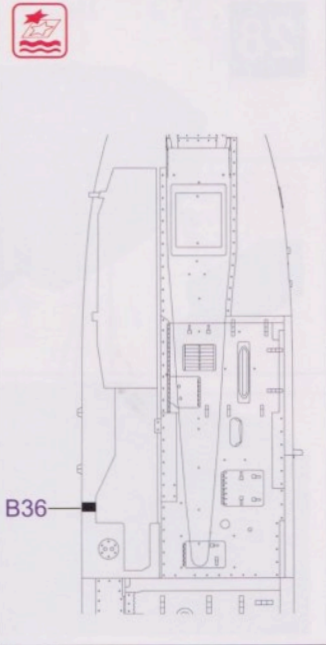
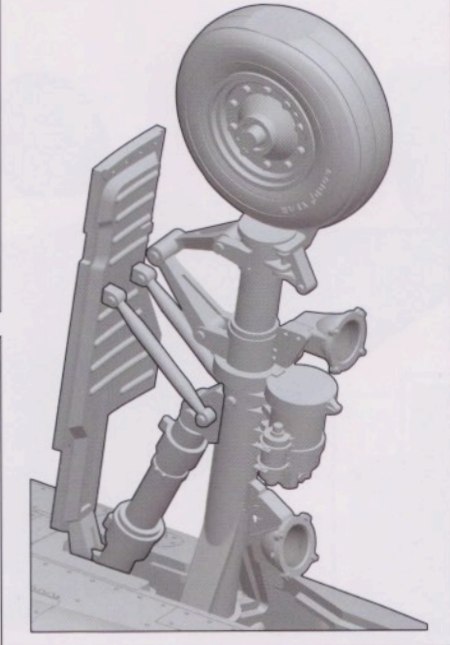
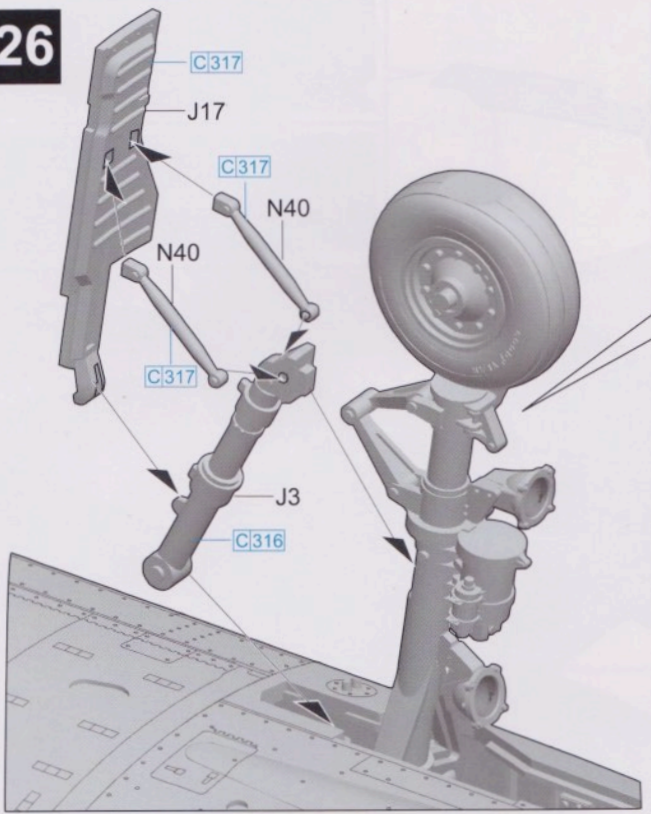

27

Canopy closed
舱盖关闭

x2

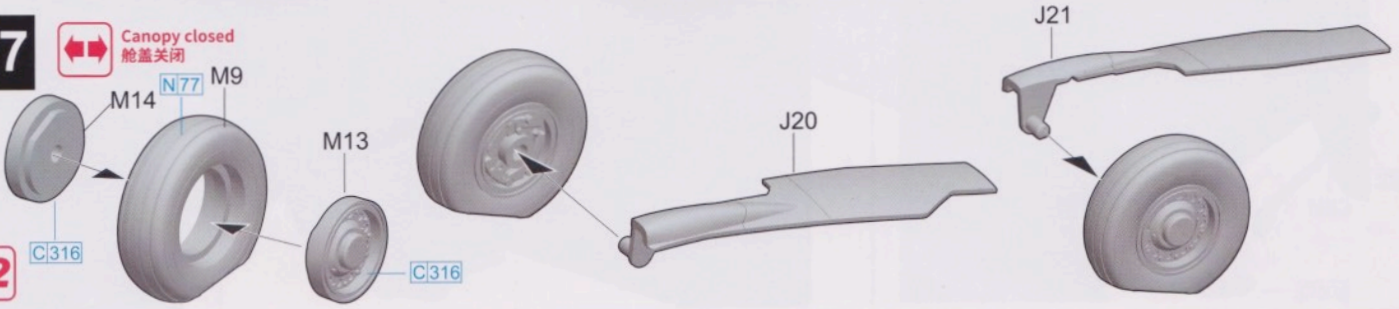

28

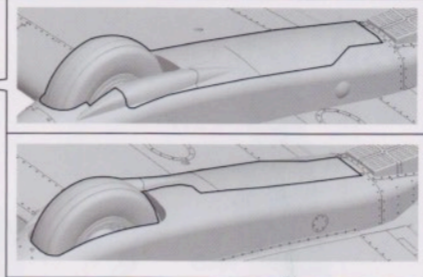
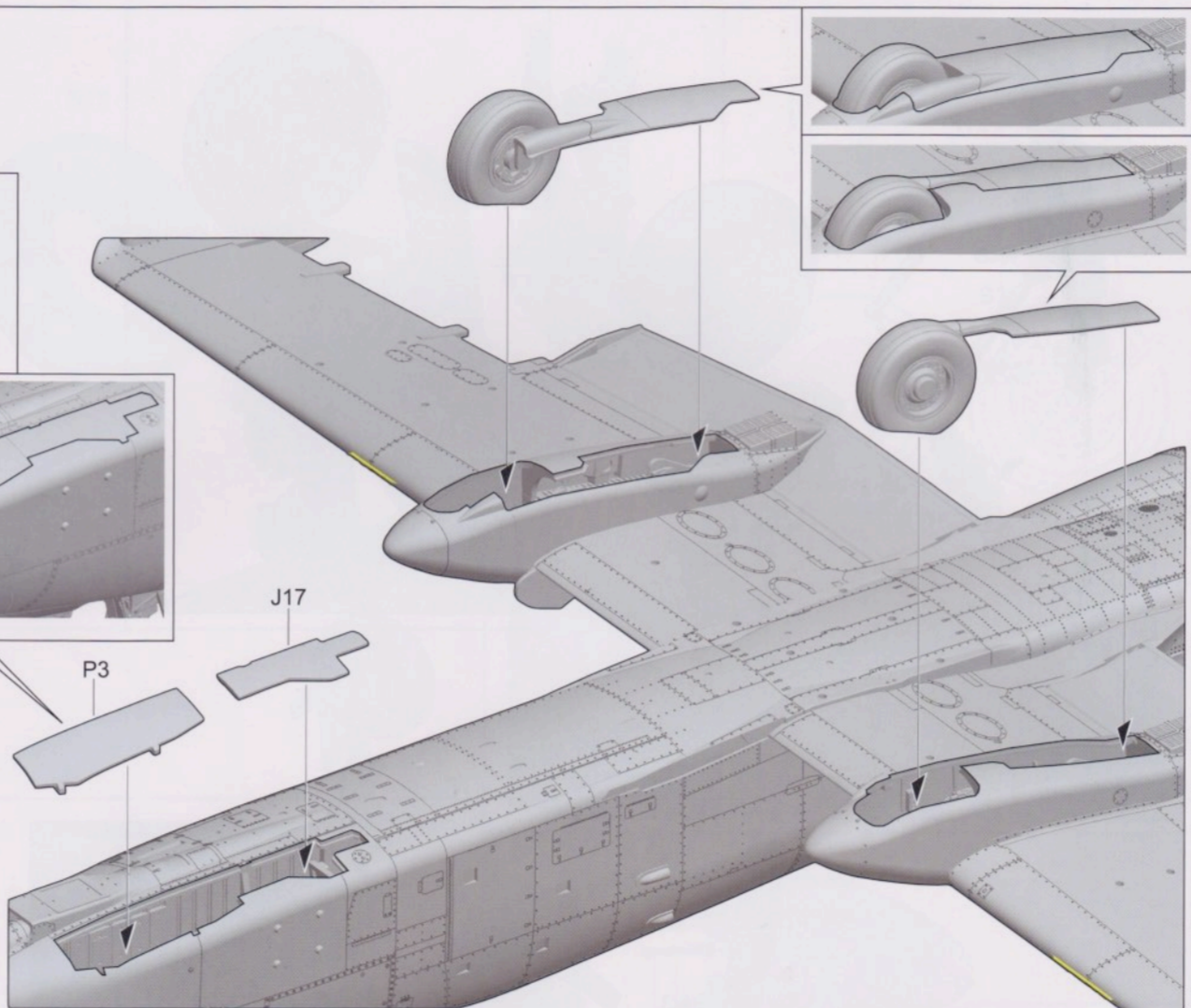
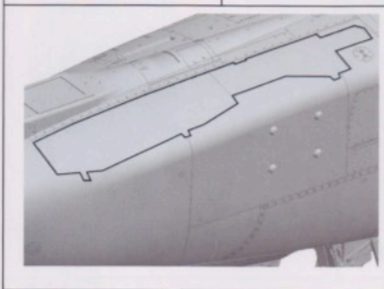

29

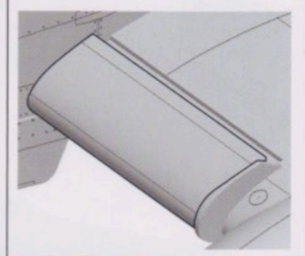
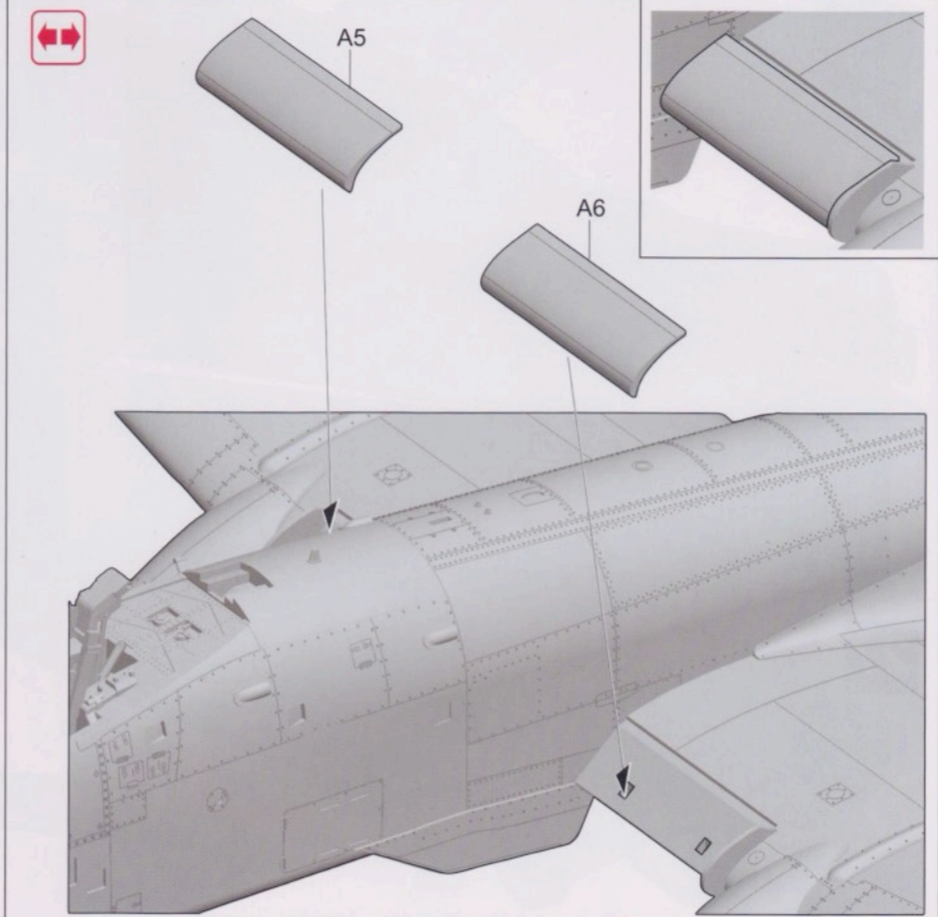
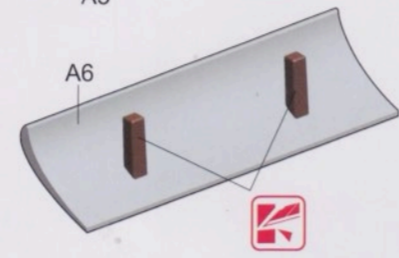
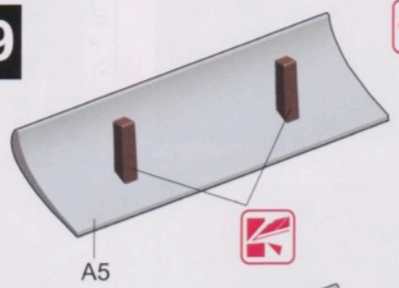

30

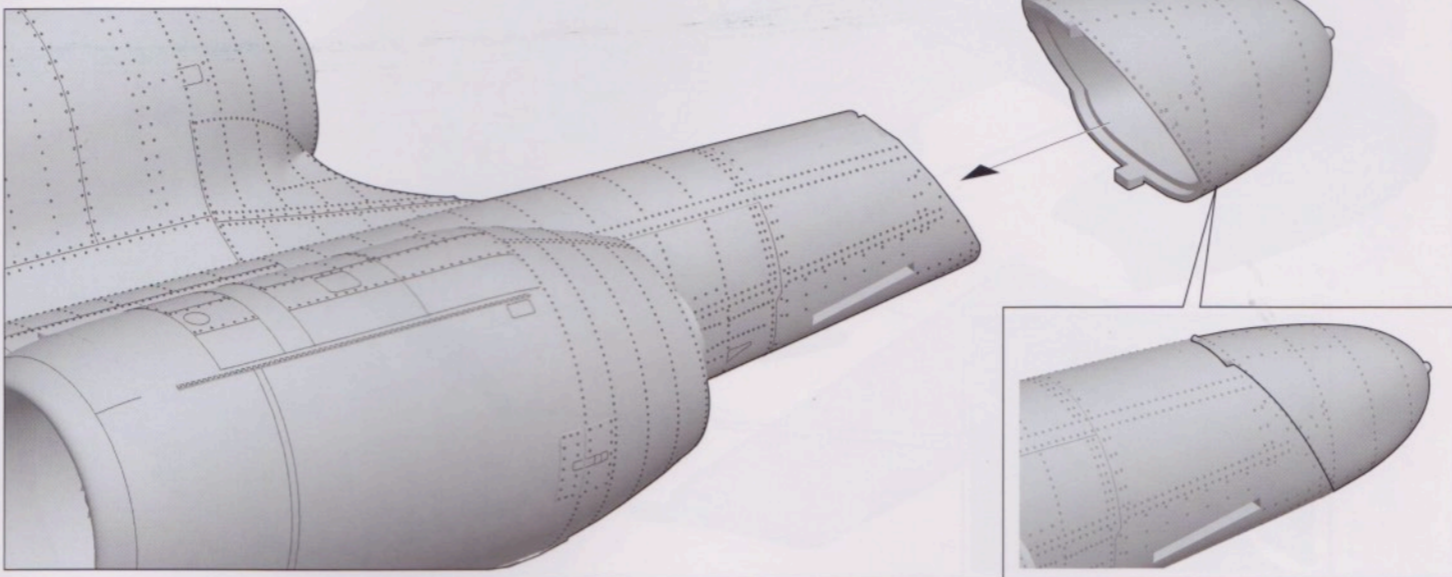

31

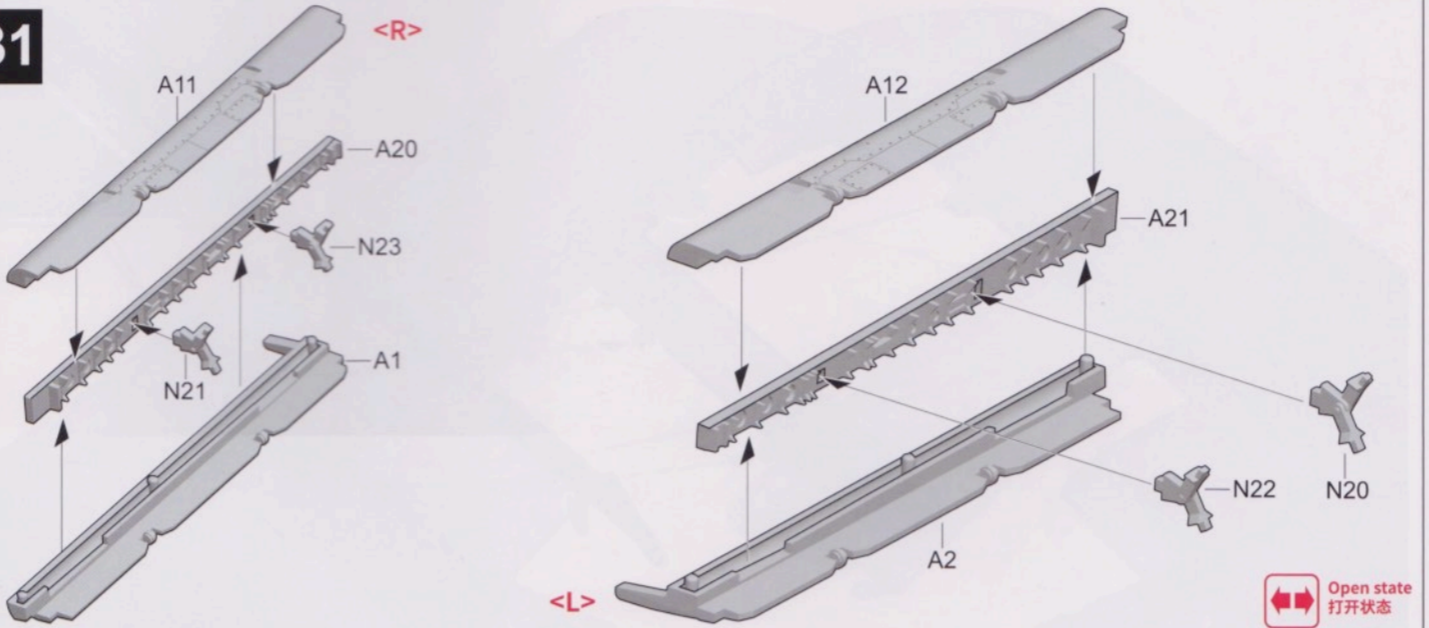

31

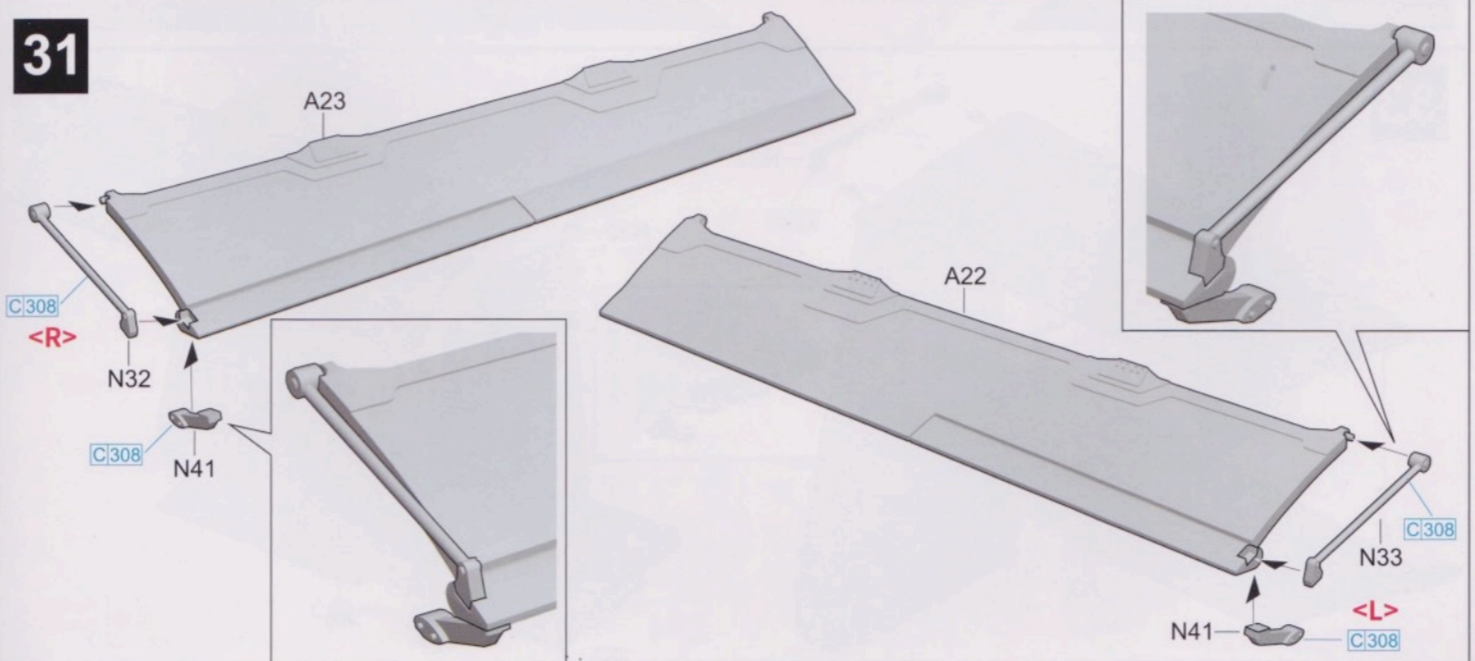

32

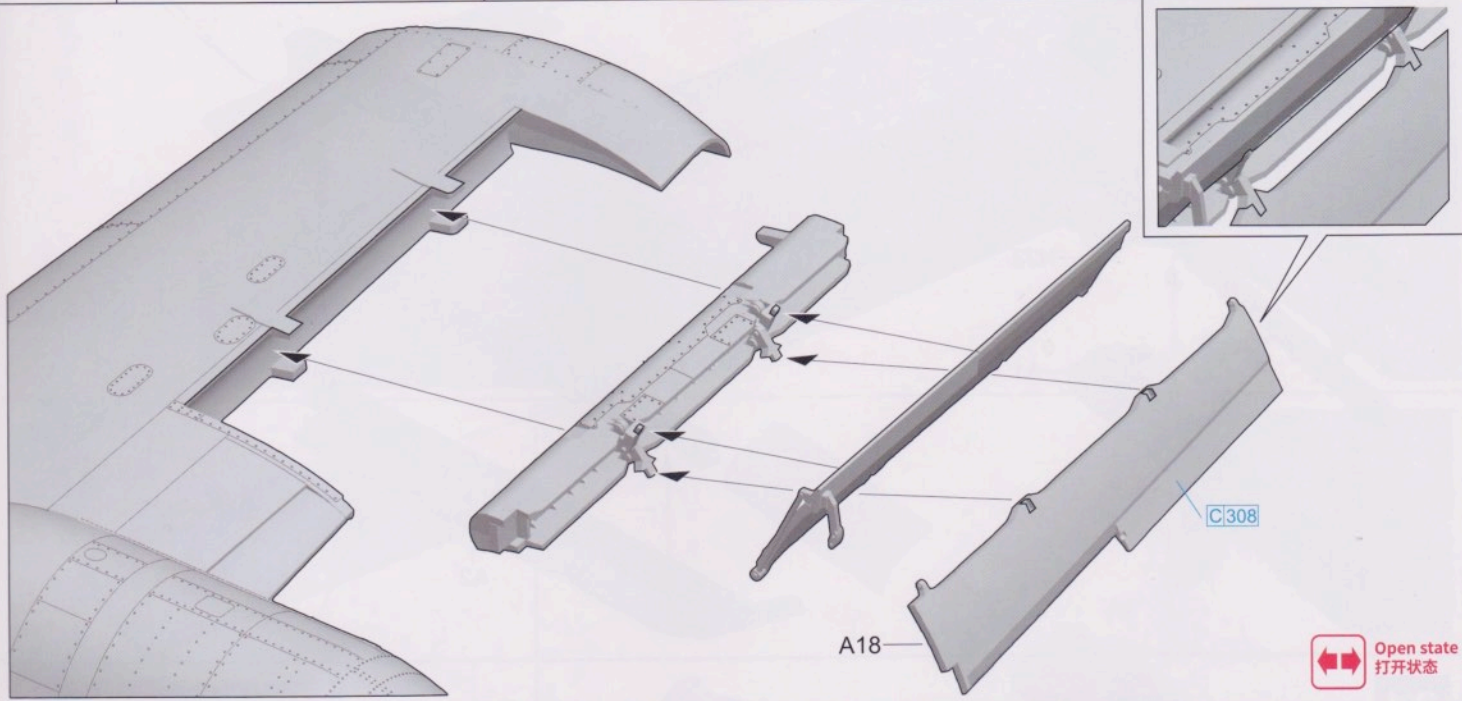
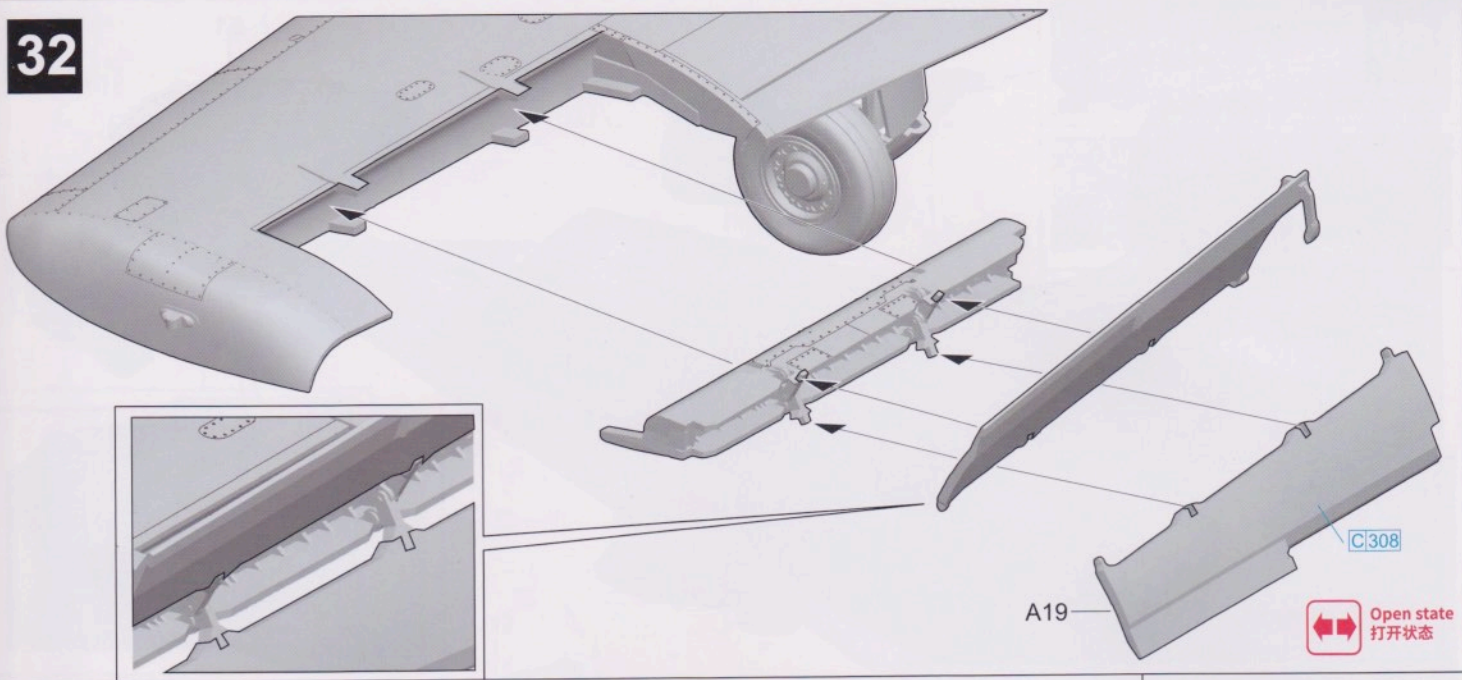

33

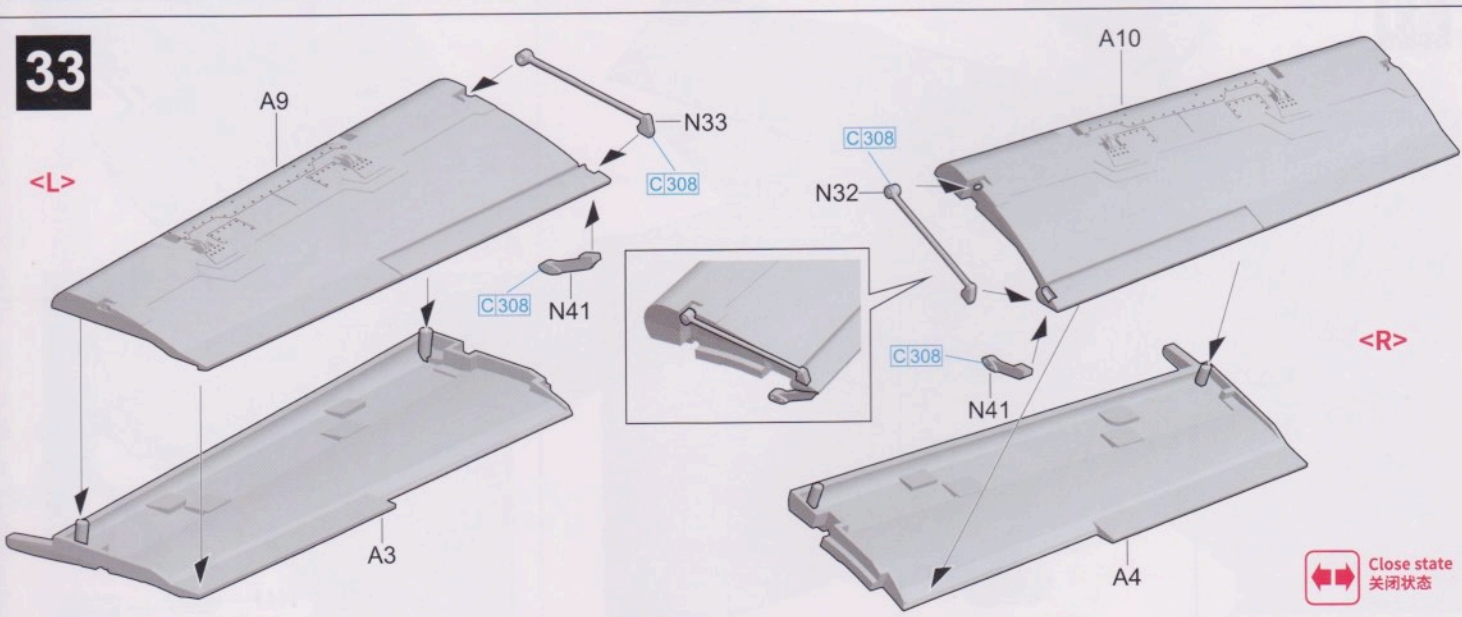

34

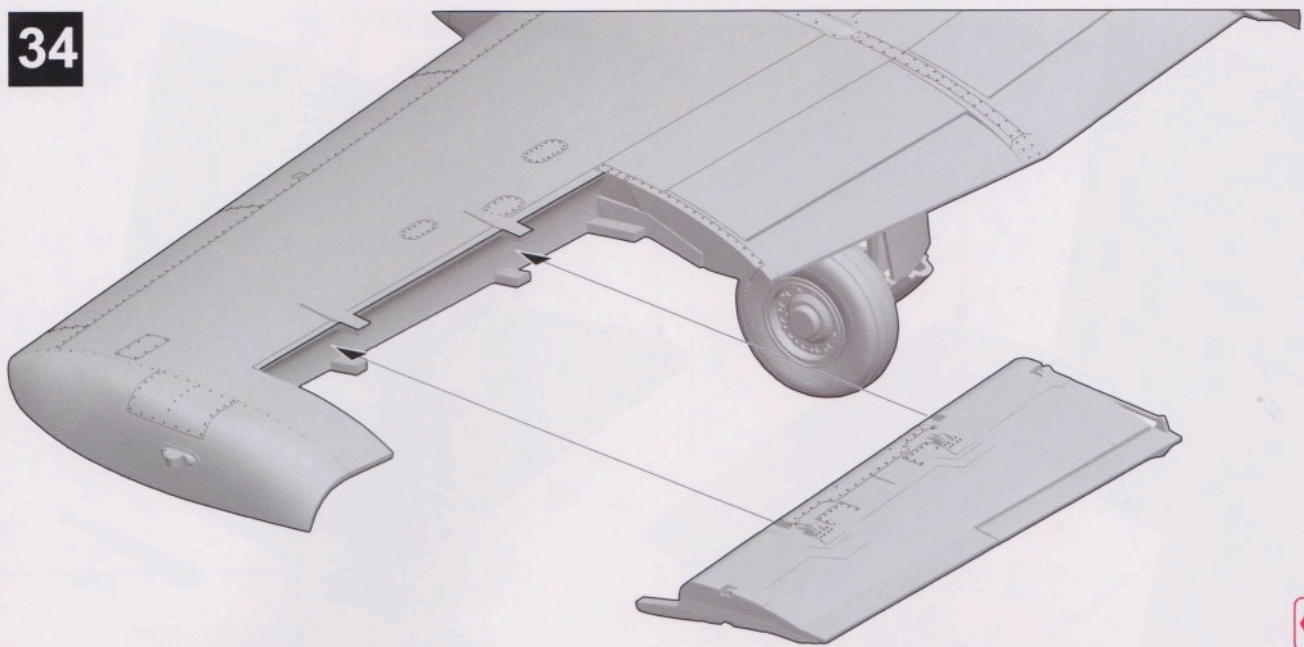

Close state
关闭状态

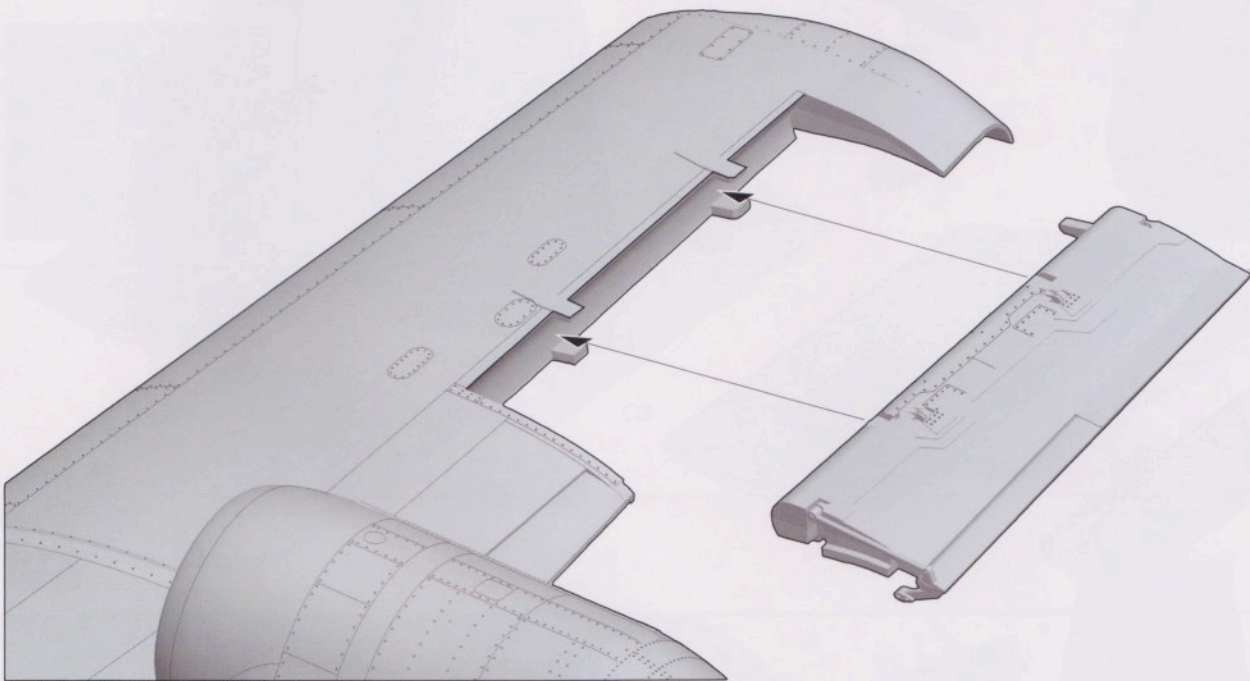

Close state
关闭状态

35

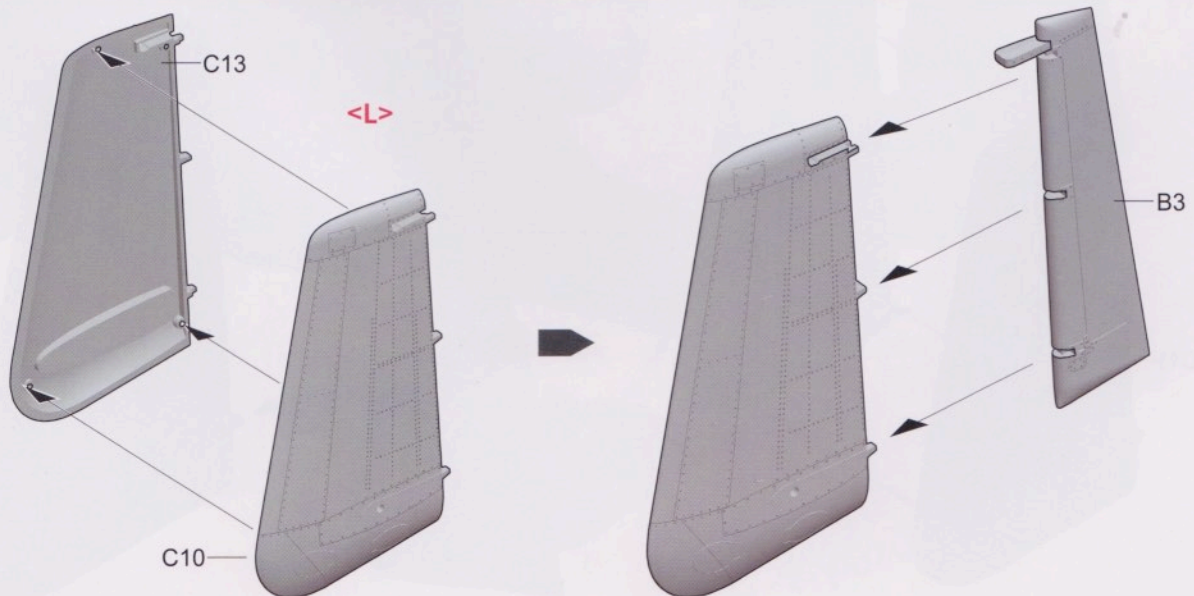

35

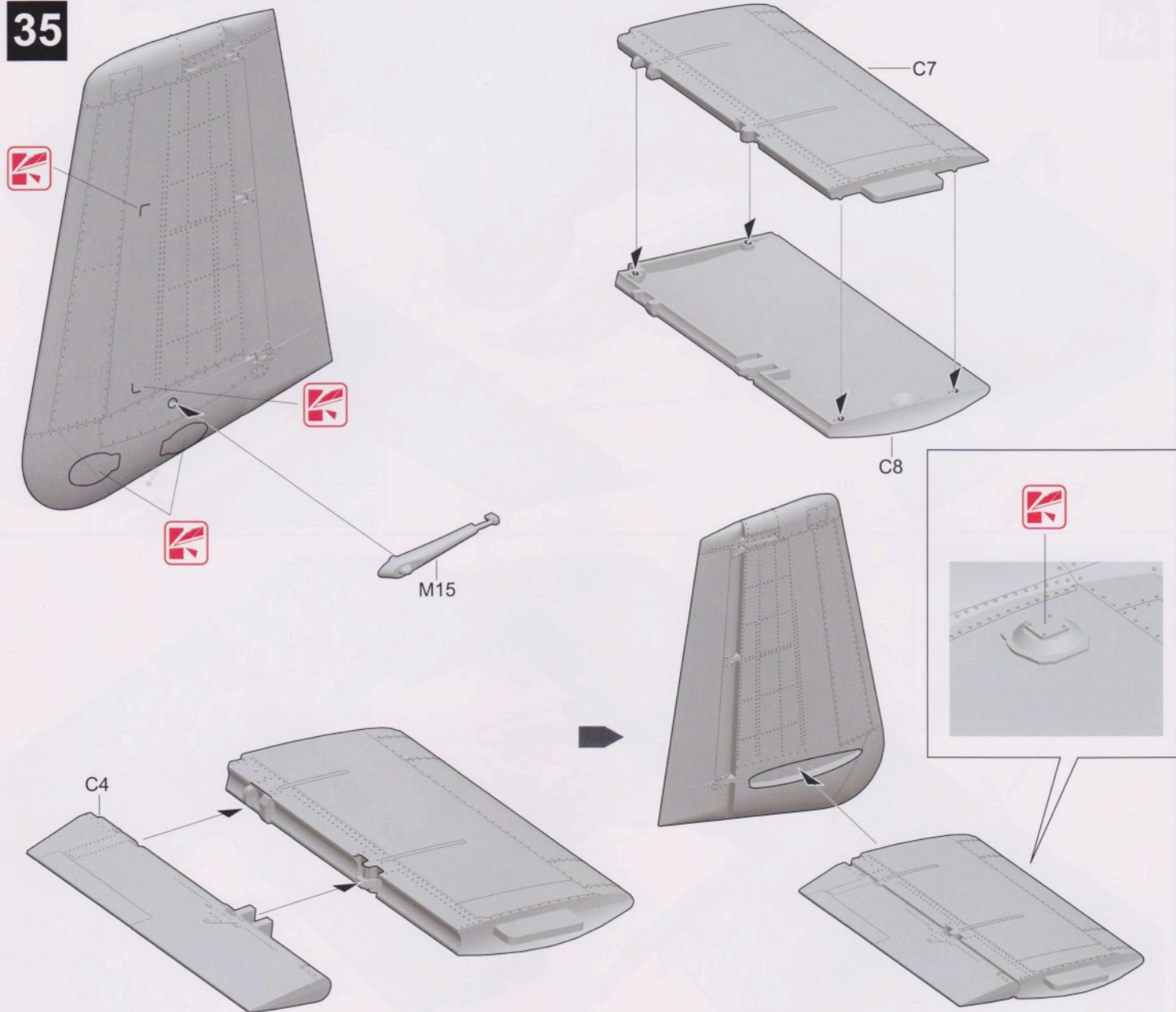

36

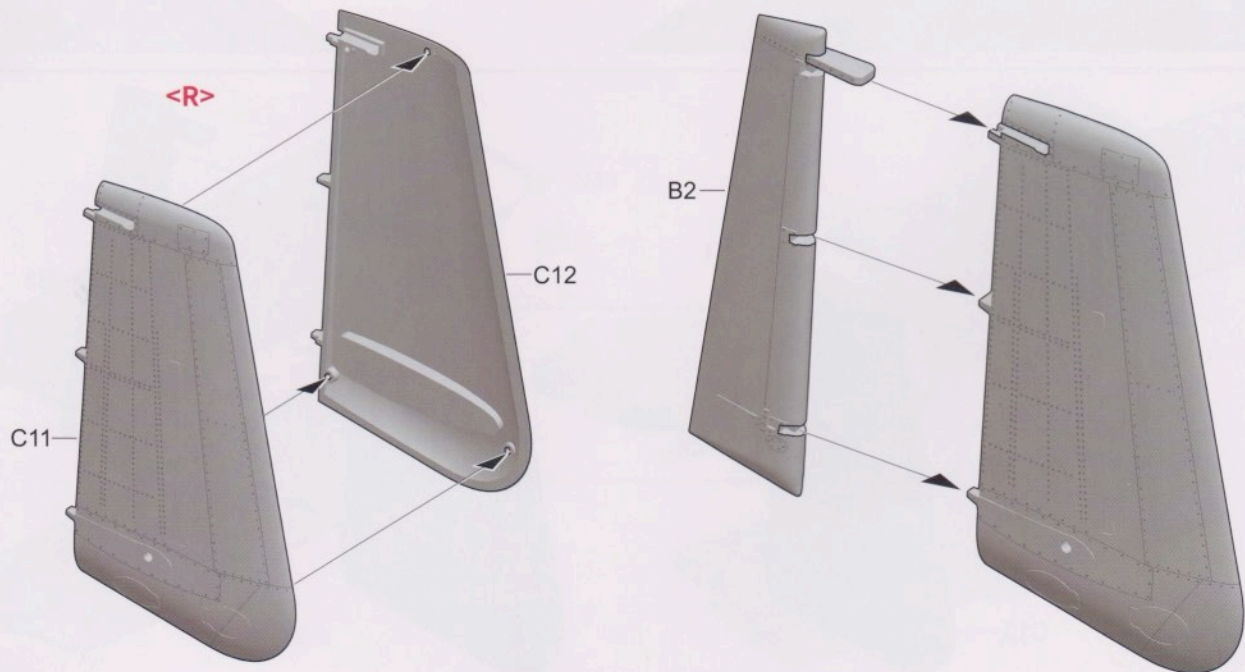

36

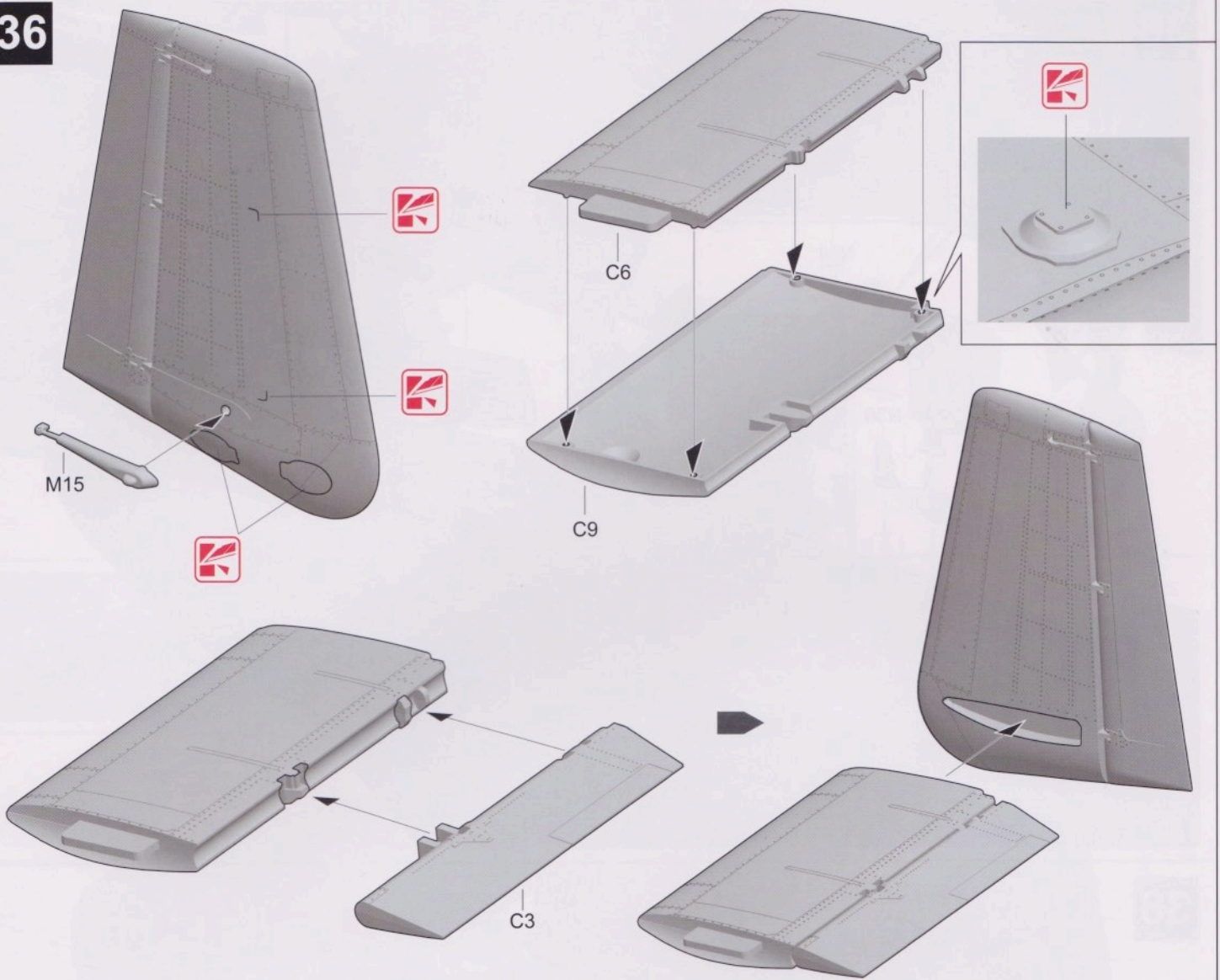

37

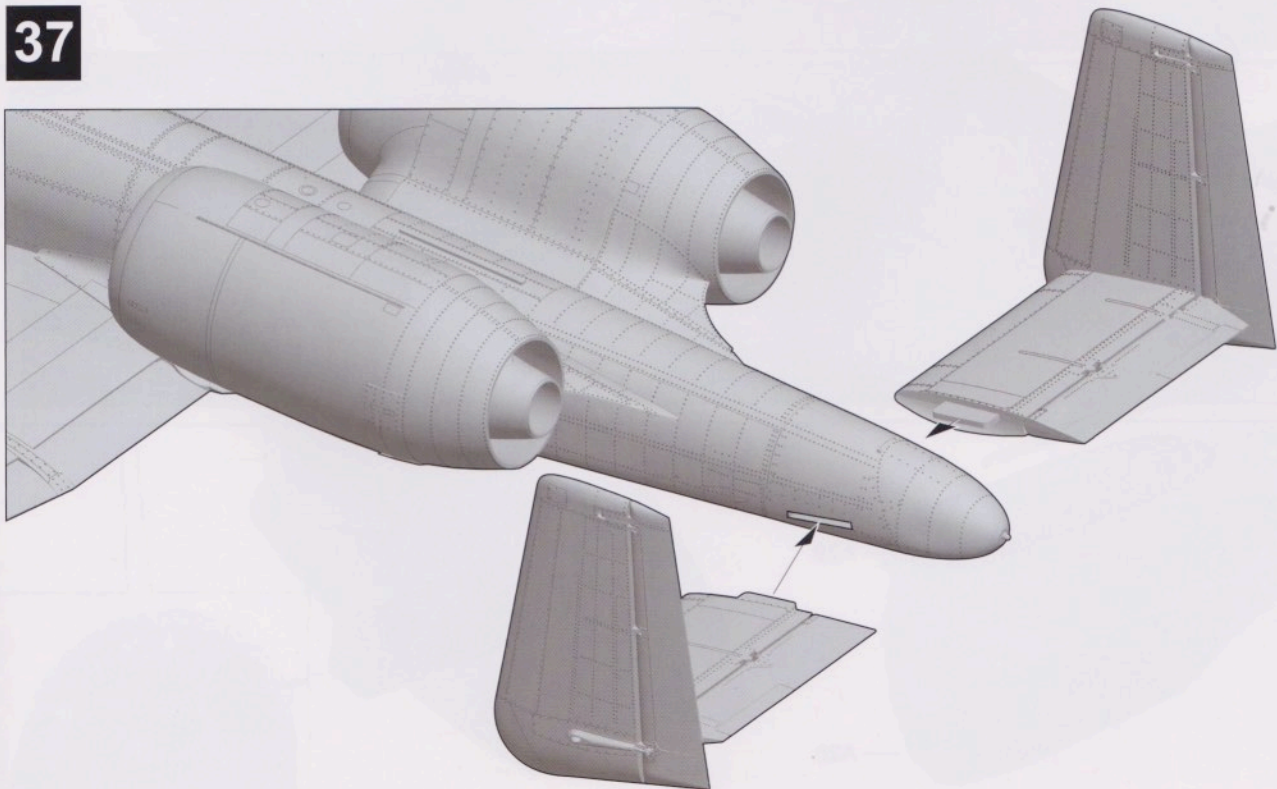

38

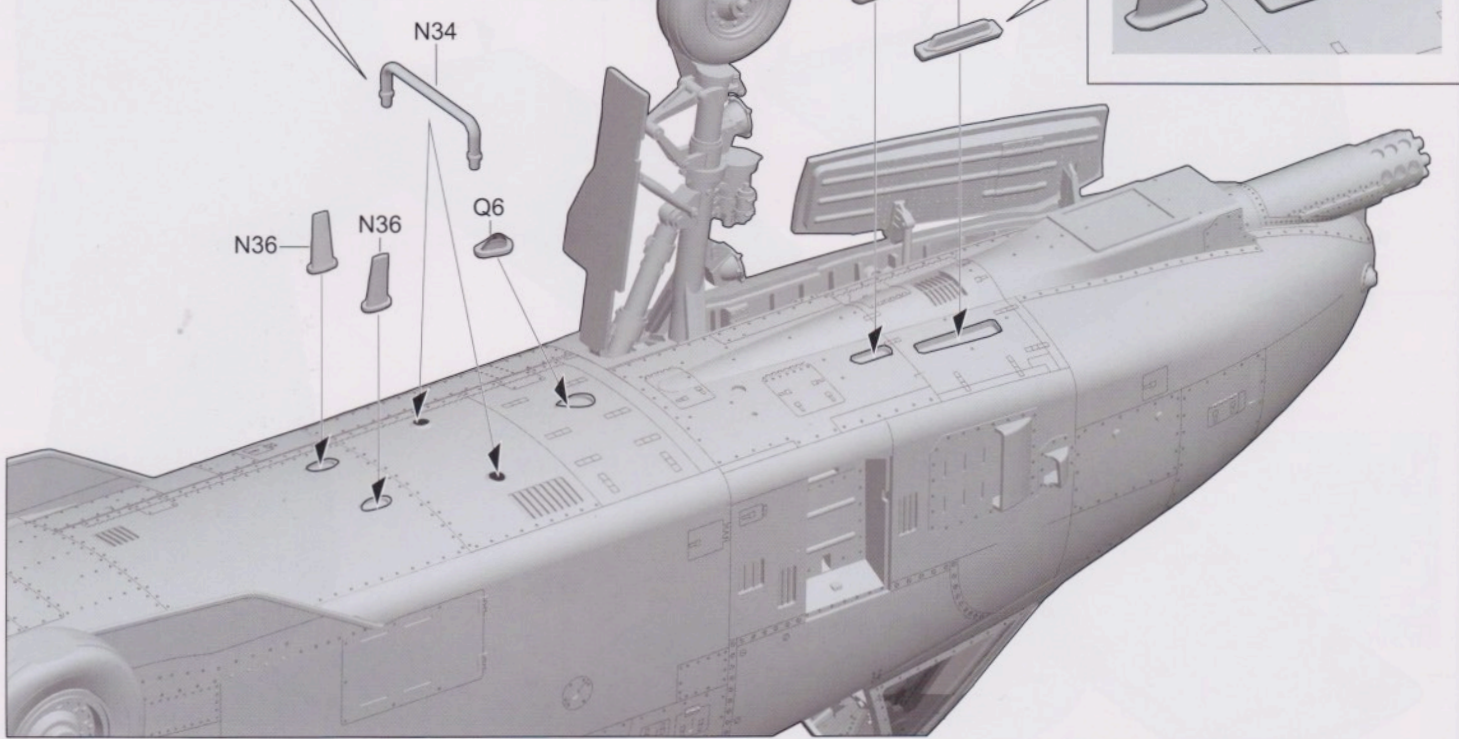
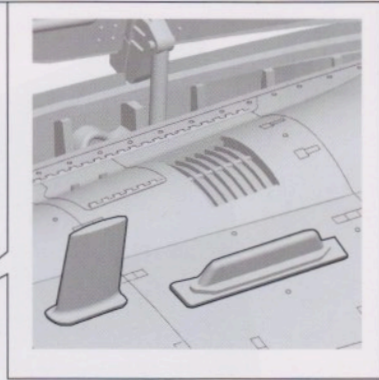
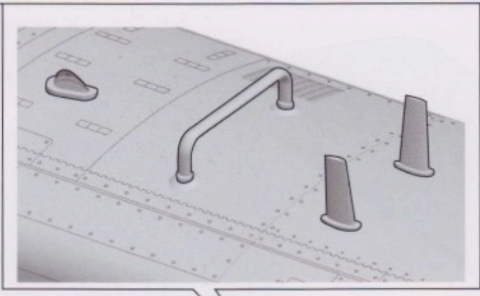

38

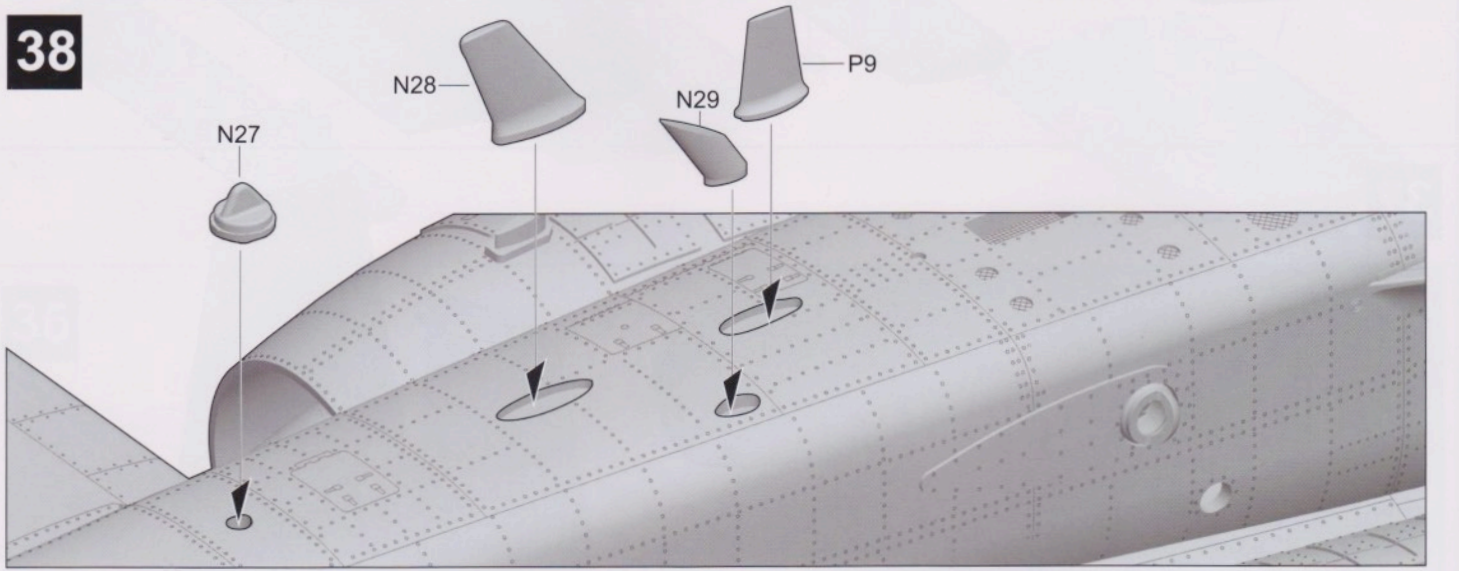

39

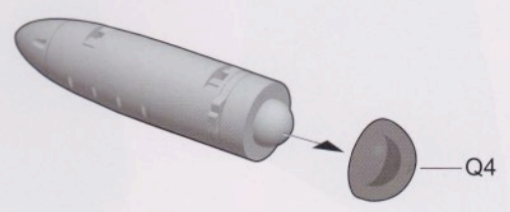
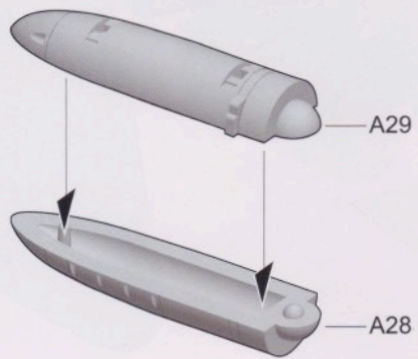

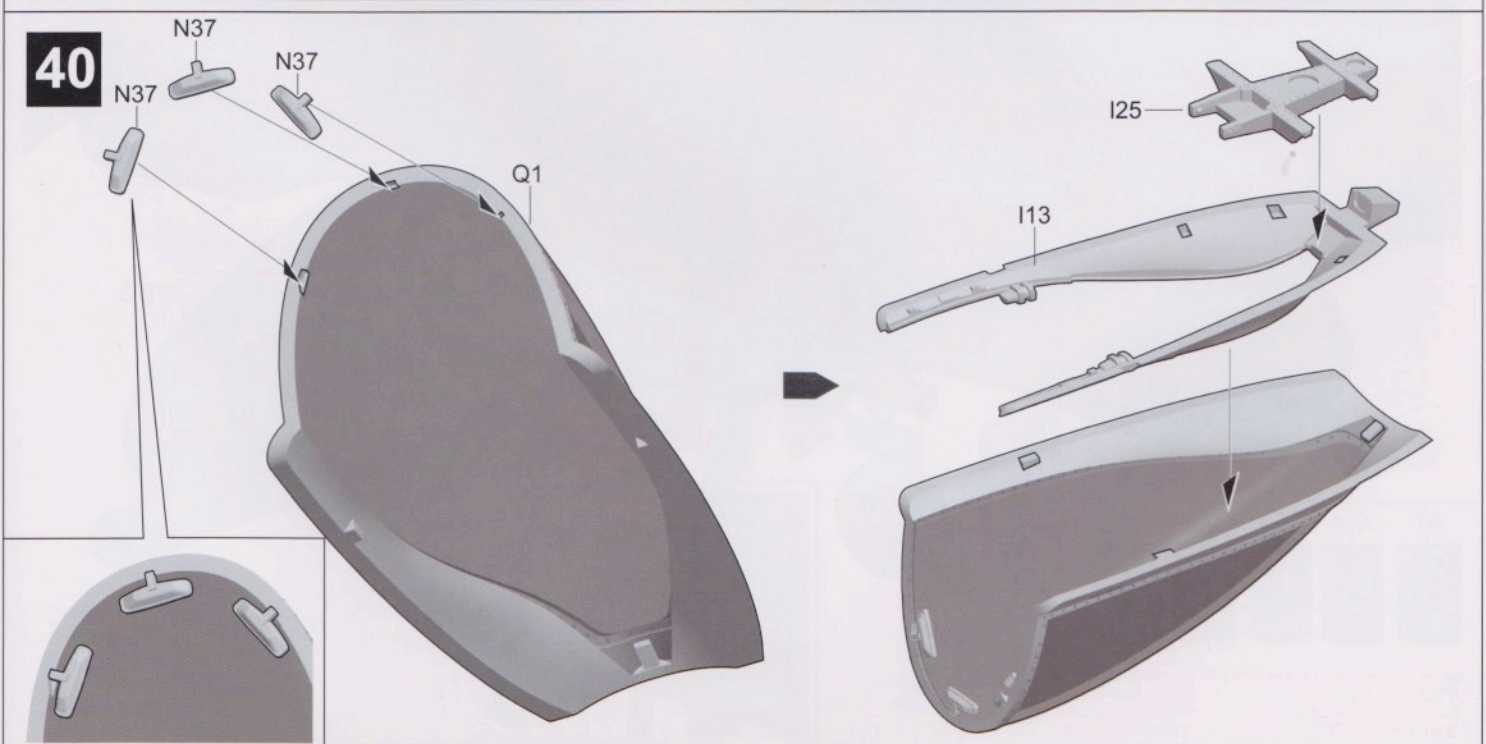
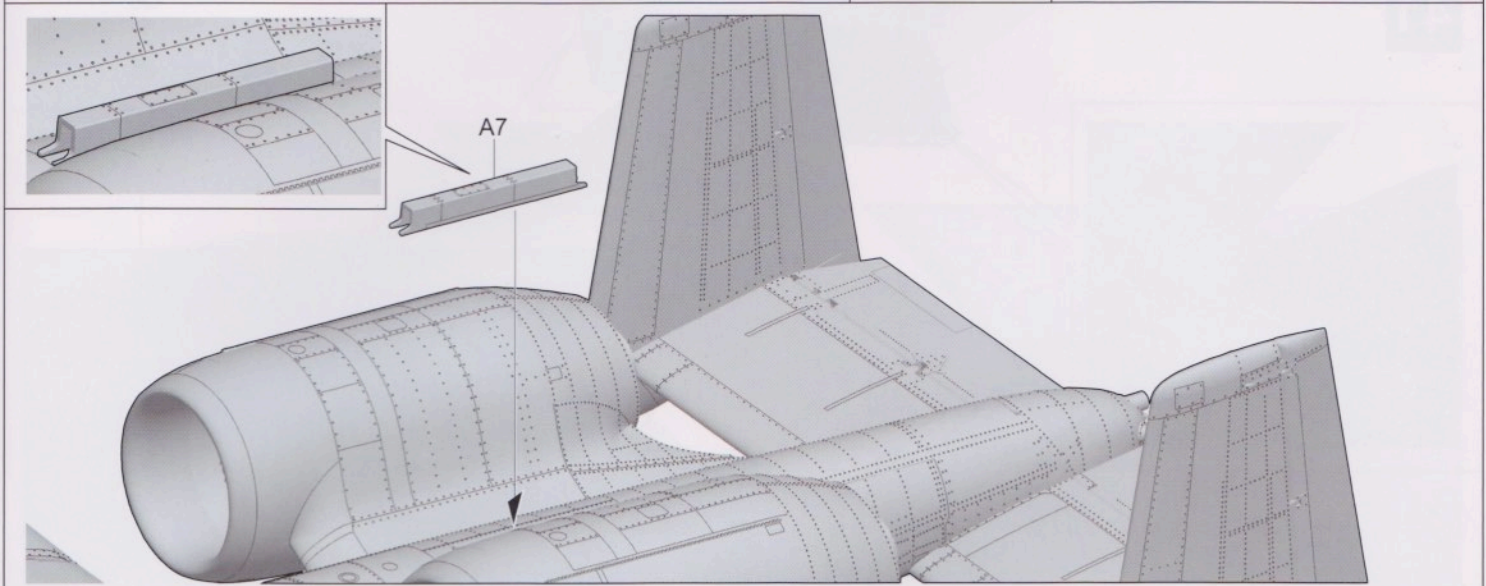
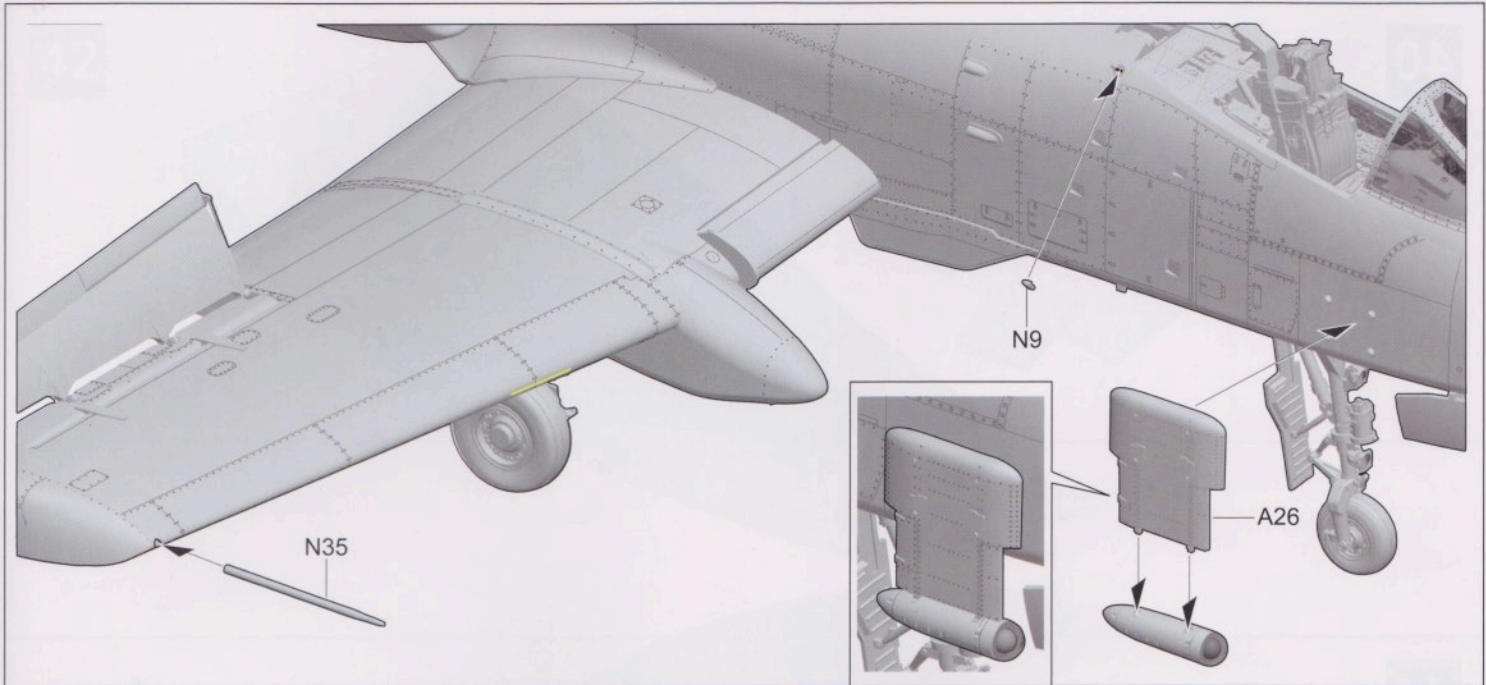

40

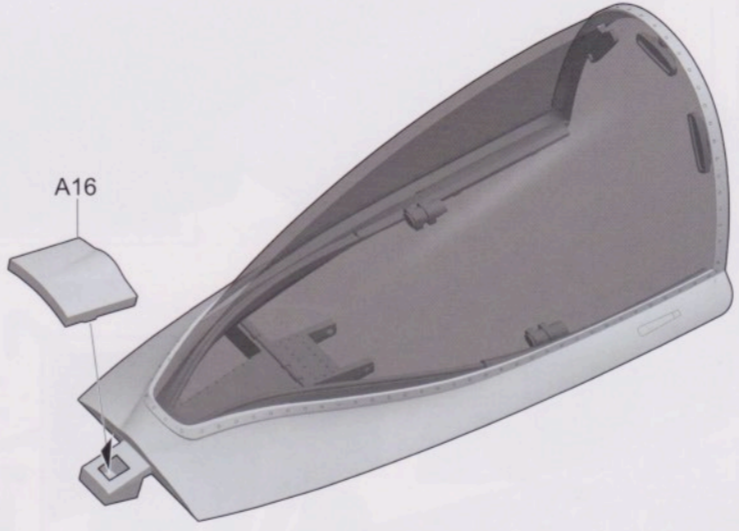

Open state
打开状态

41

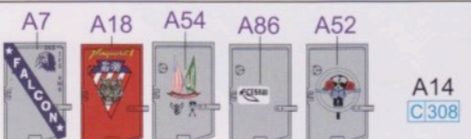
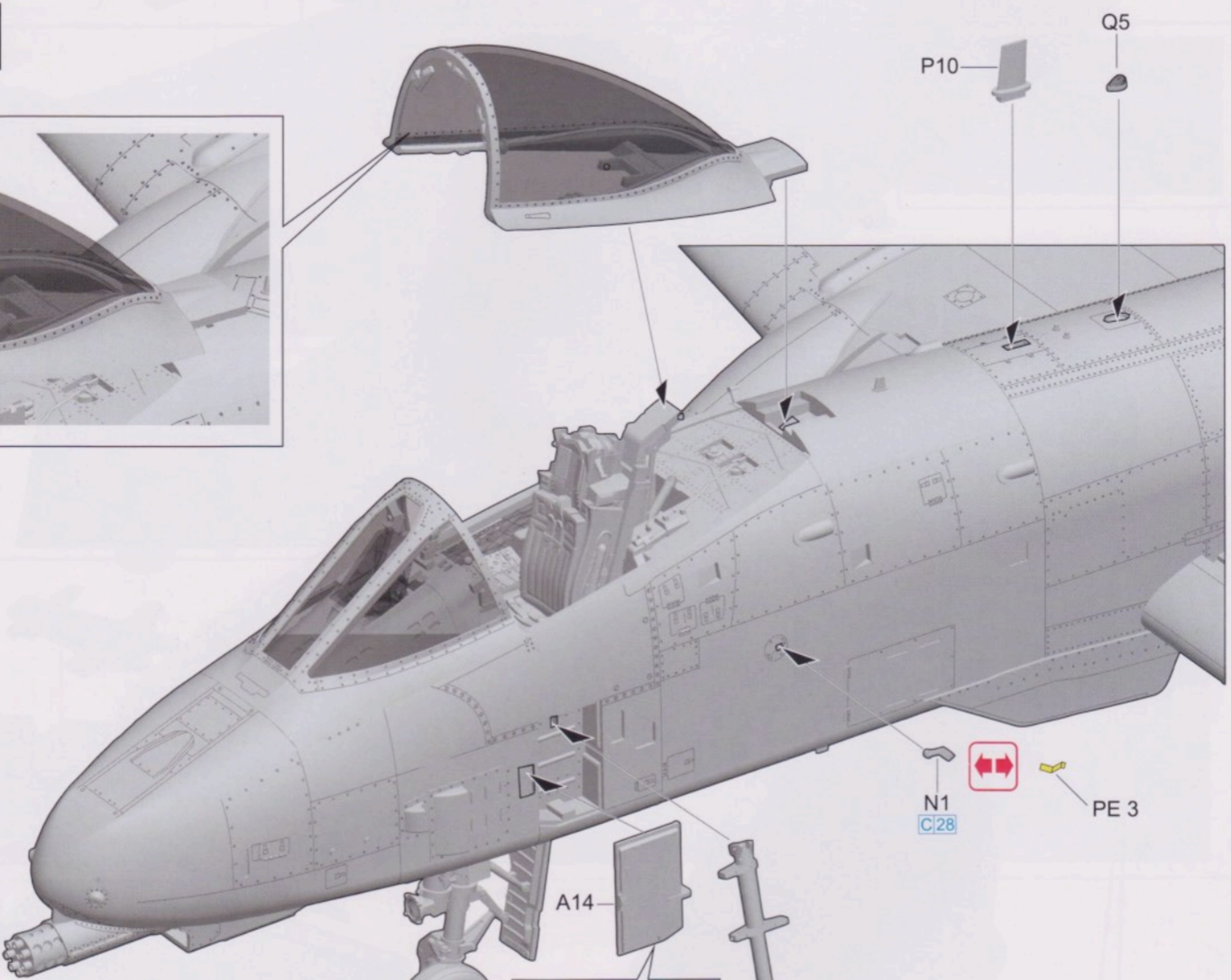
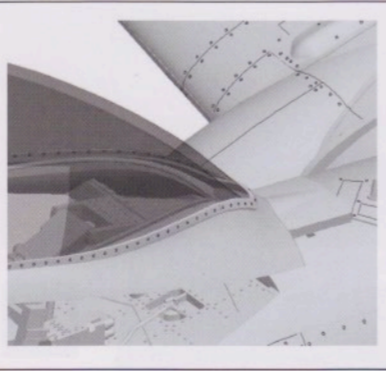

Painting scheme B for use A54/A86
涂装B使用水贴A54/A86
Painting scheme C for use A18
涂装C使用水贴A18
Painting scheme D for use A7
涂装D使用水贴A7
Painting scheme E for use A52
涂装E使用水贴A52

Open state
打开状态

42

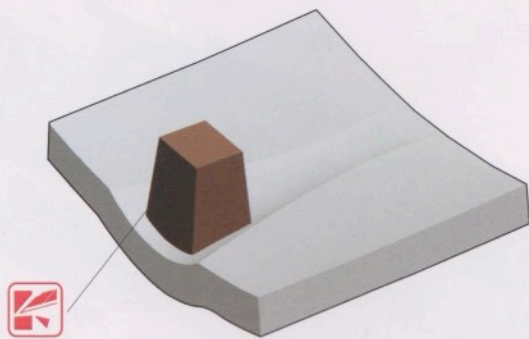

A16

Close state
关闭状态

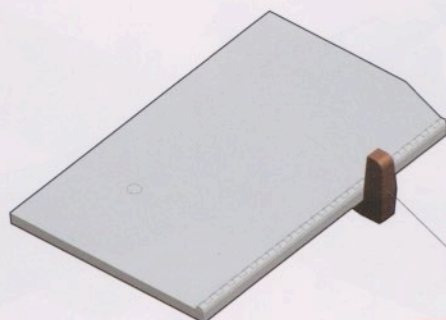

A14

Close state
关闭状态

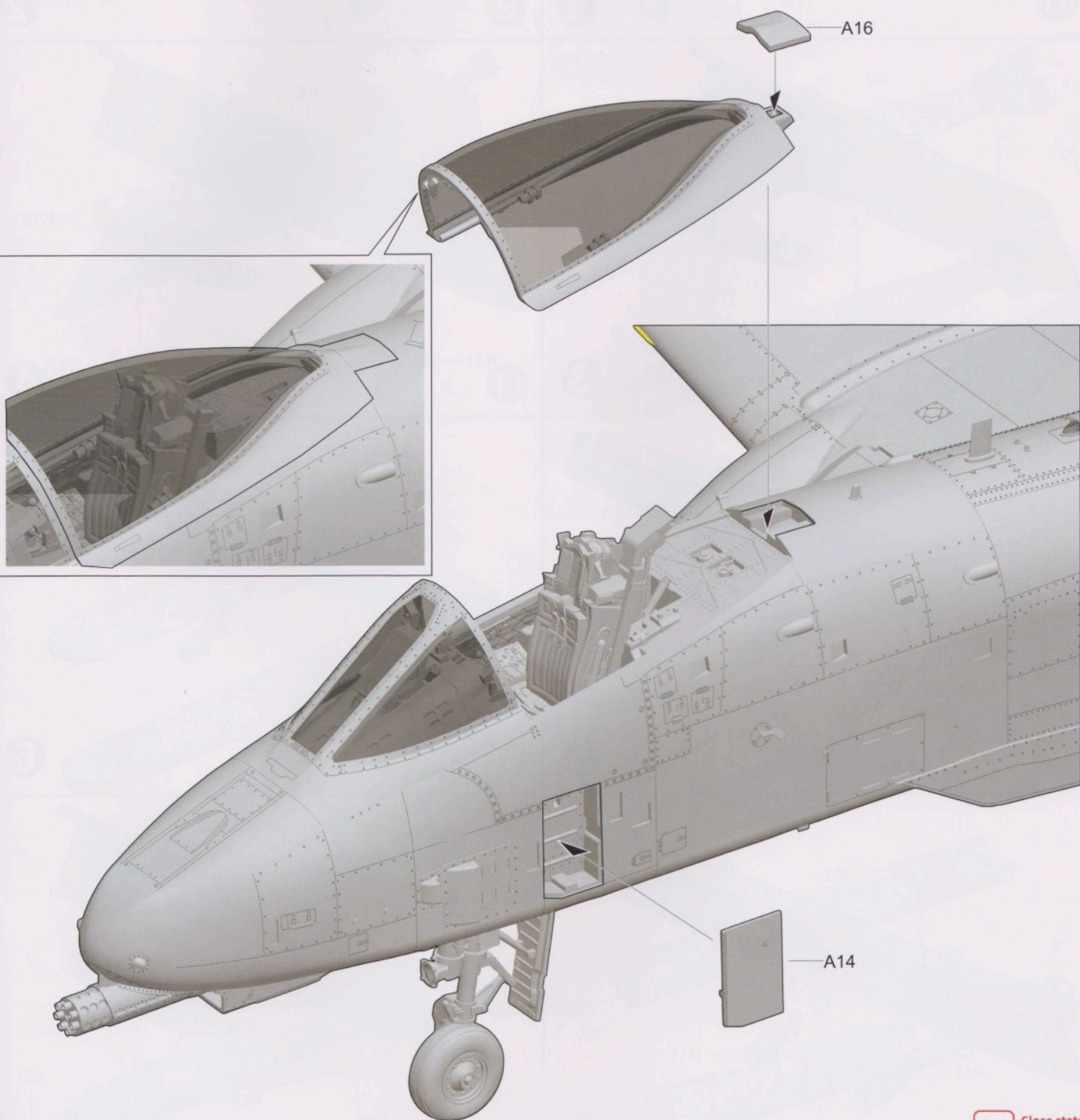

A16

A14

Close state
关闭状态

43

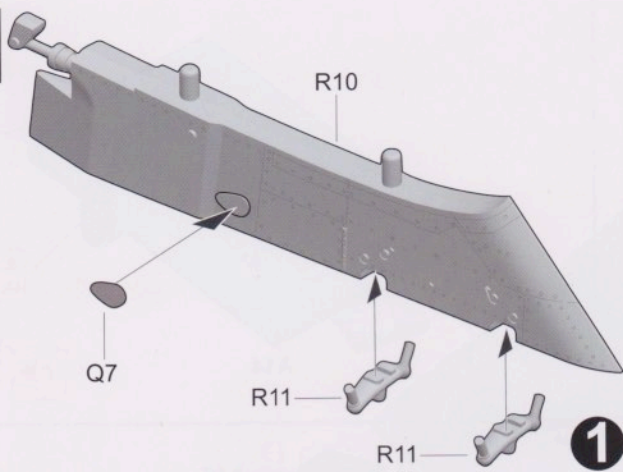

1

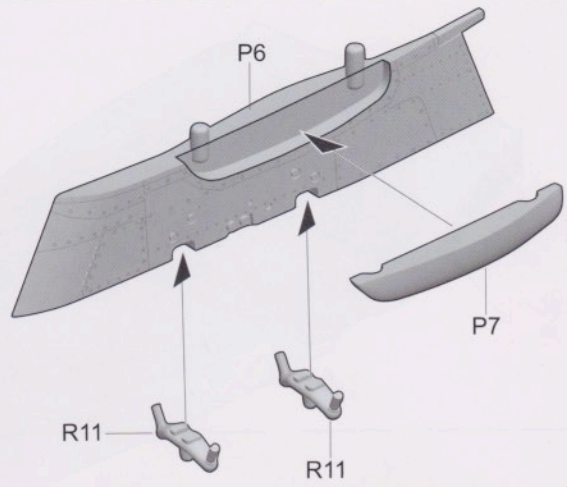

2

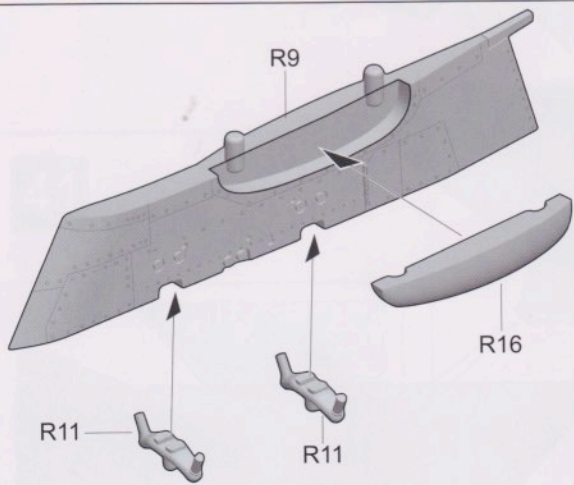

3

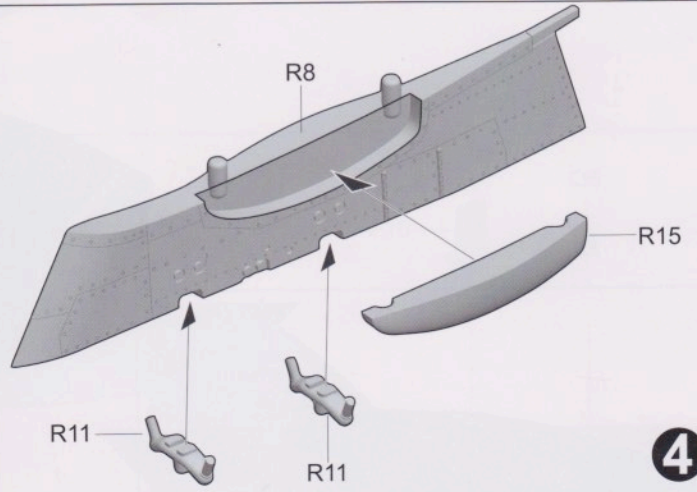

4

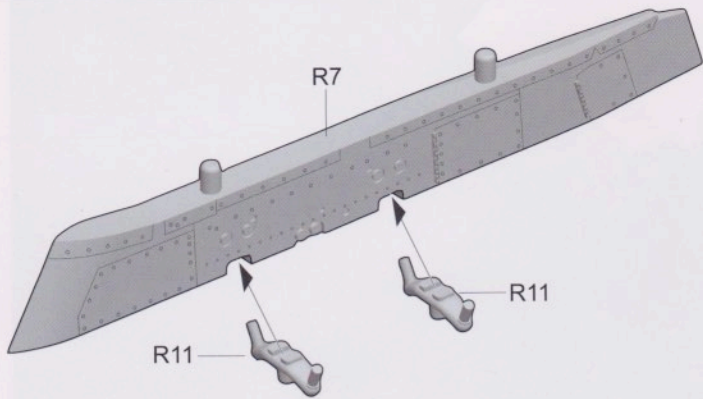

5

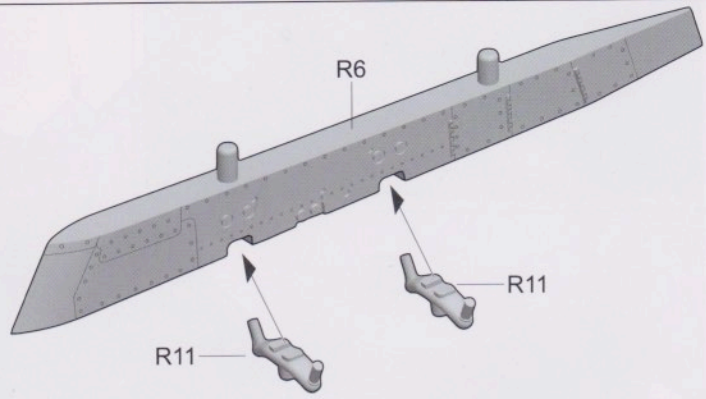

6

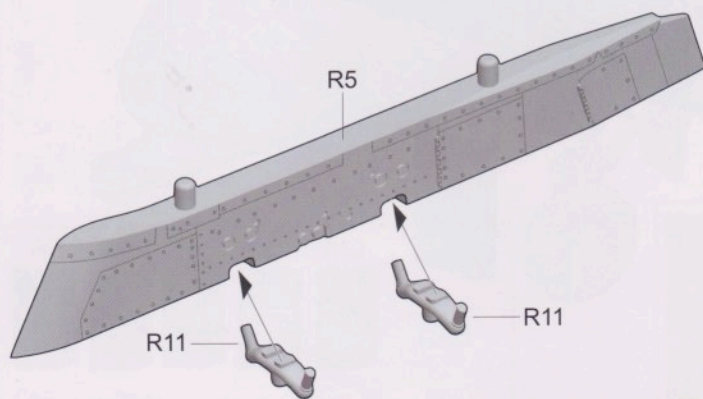

7

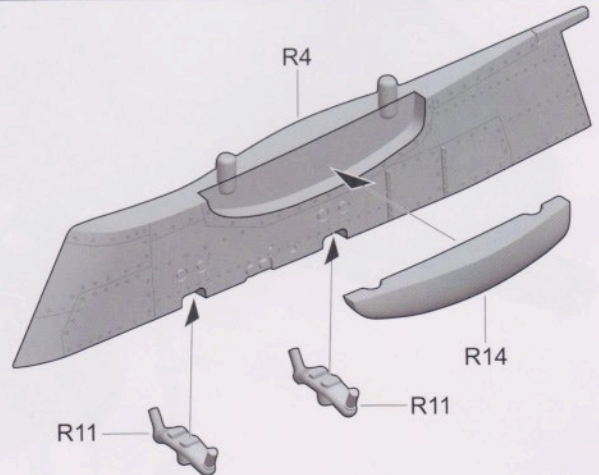

8

43

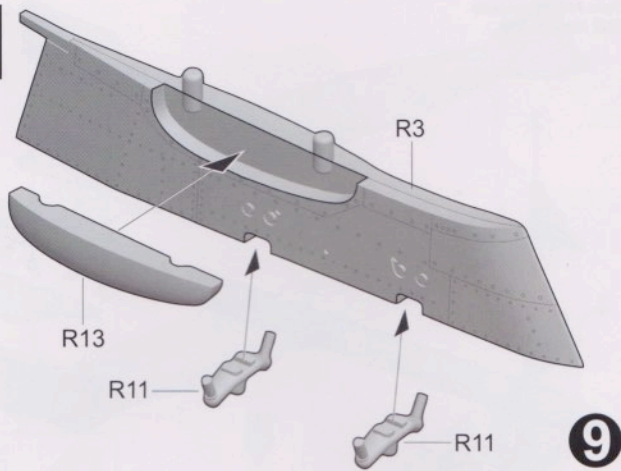

9

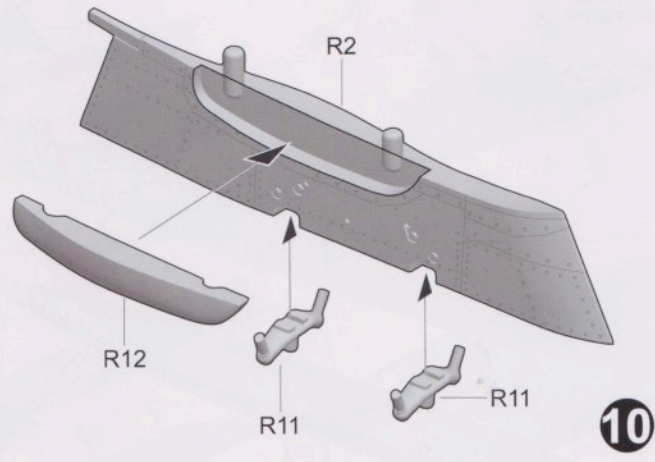

10

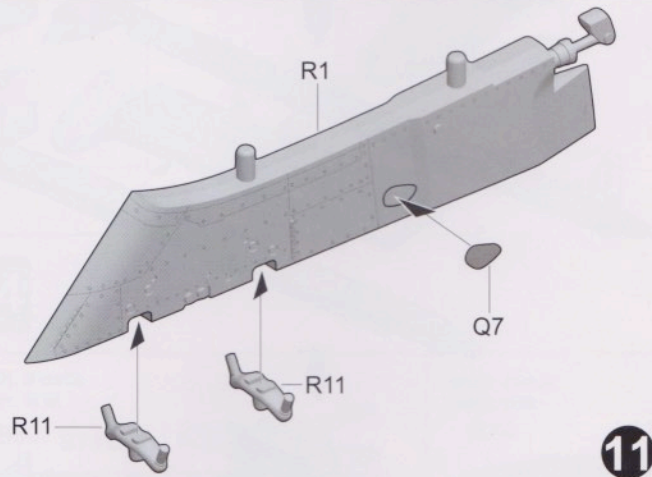

11

AGM-65 Maverick
小牛 空对地导弹

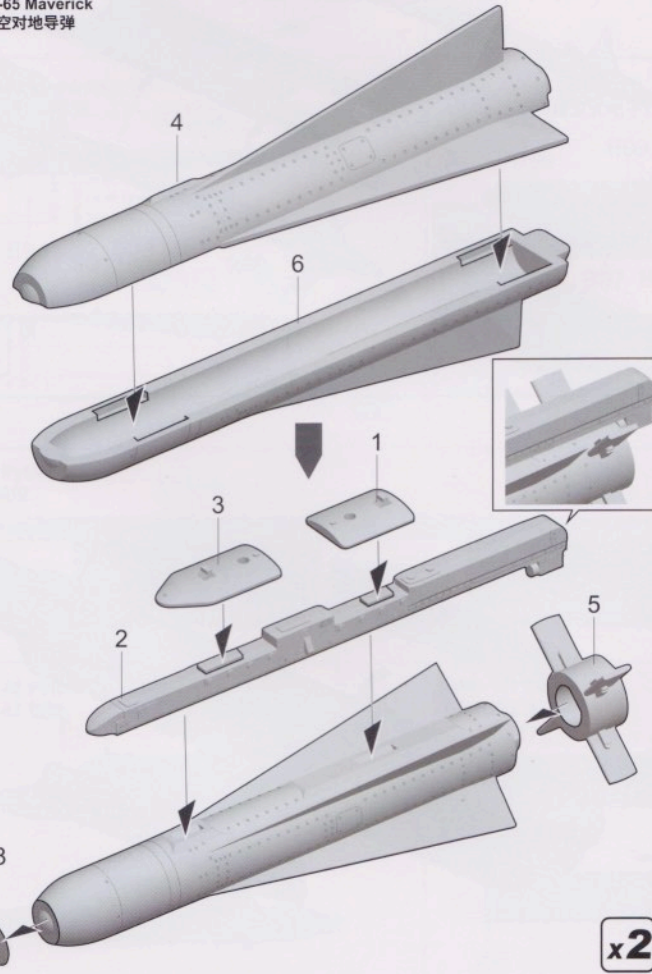

x2

MK83 Bomb
MK83 炸弹

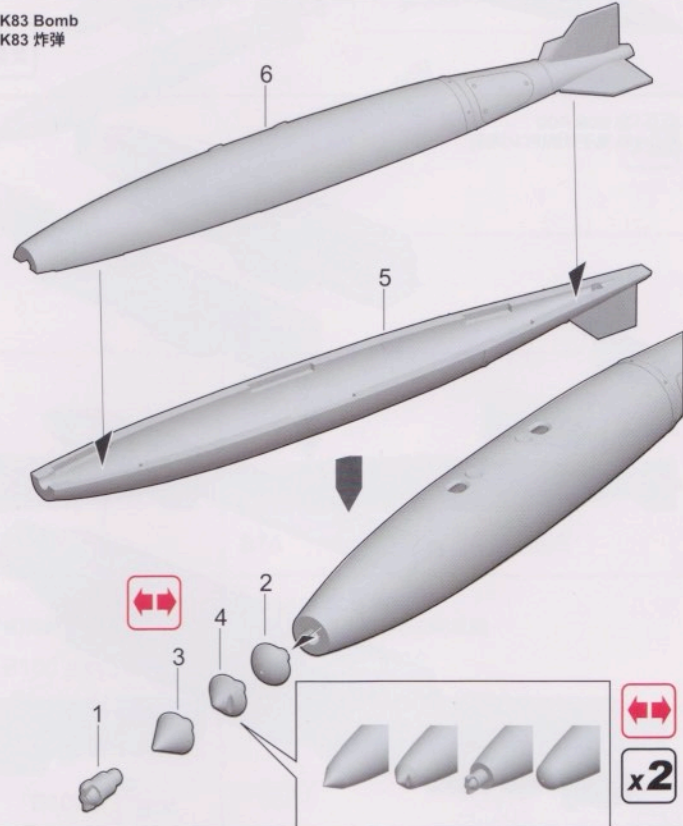

x2

LAU-131 Launcher
LAU-131 火箭巢

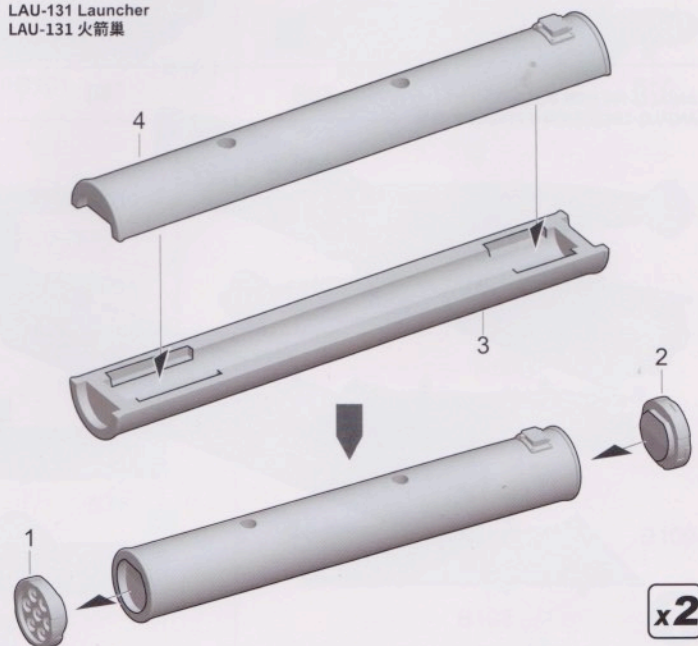

x2

A-10 TANK
A-10 副油箱

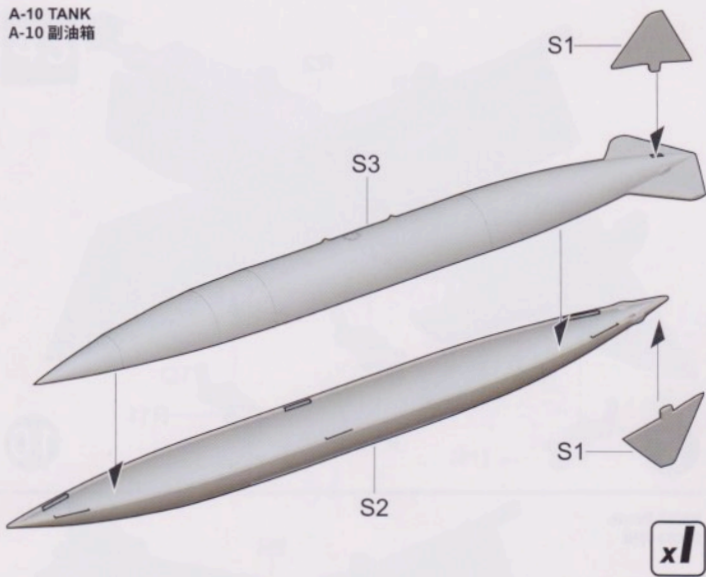

Twin AIM-9L missile
双联 AIM-9L 导弹

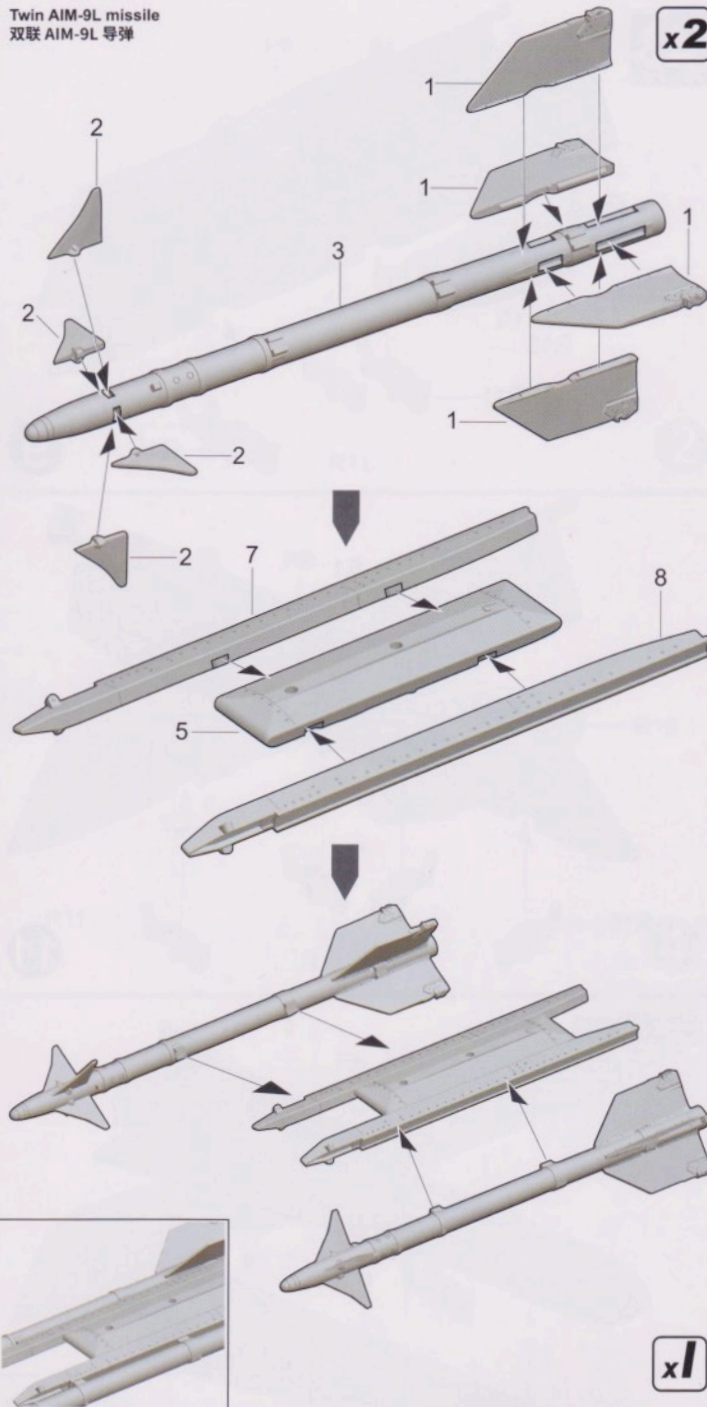

ALQ-131 ECM POD
ALQ-131 电子对抗(ECM)吊舱

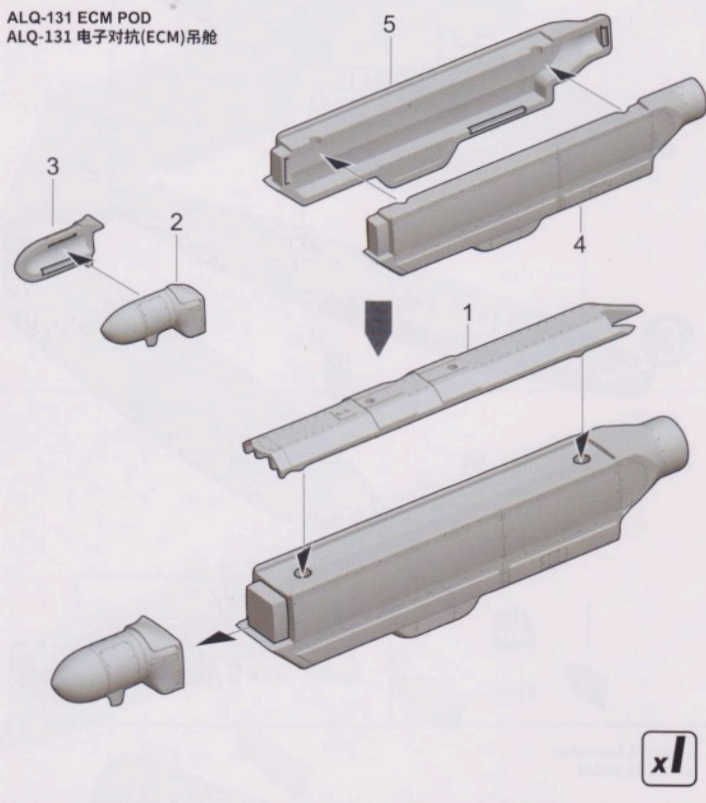

AN/ALQ-184 ECM POD
AN/ALQ-184 自卫式电子对抗(ECM)吊舱

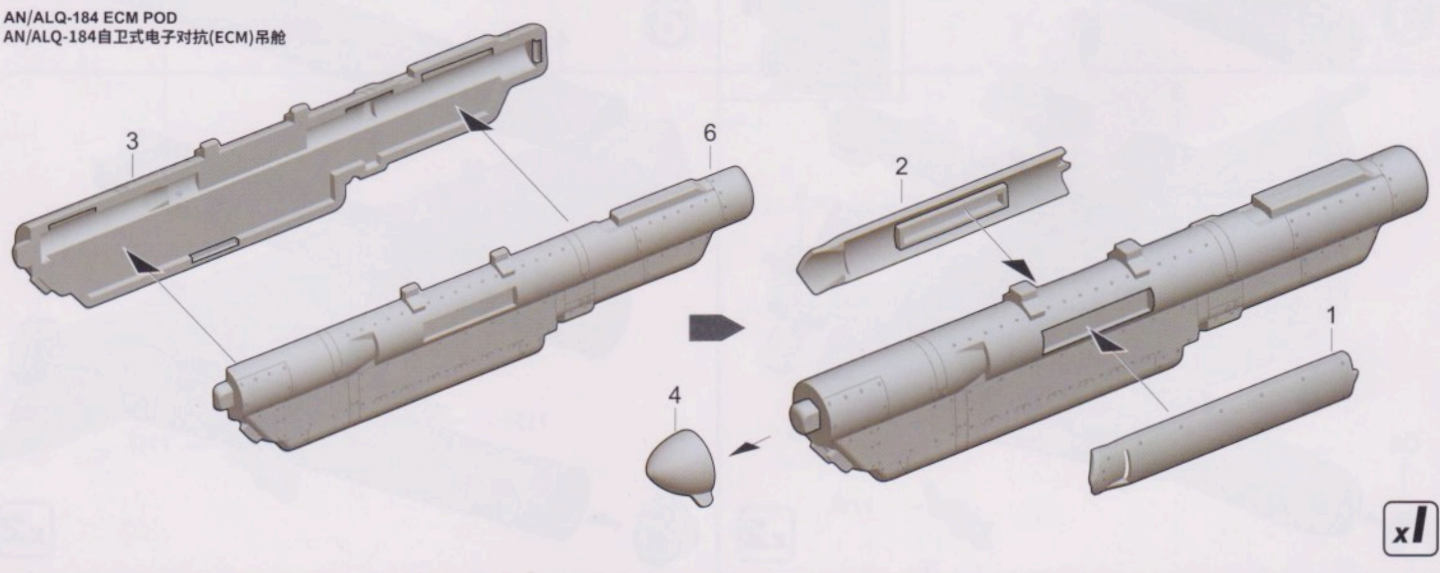

MK82 Bomb
MK82 炸弹

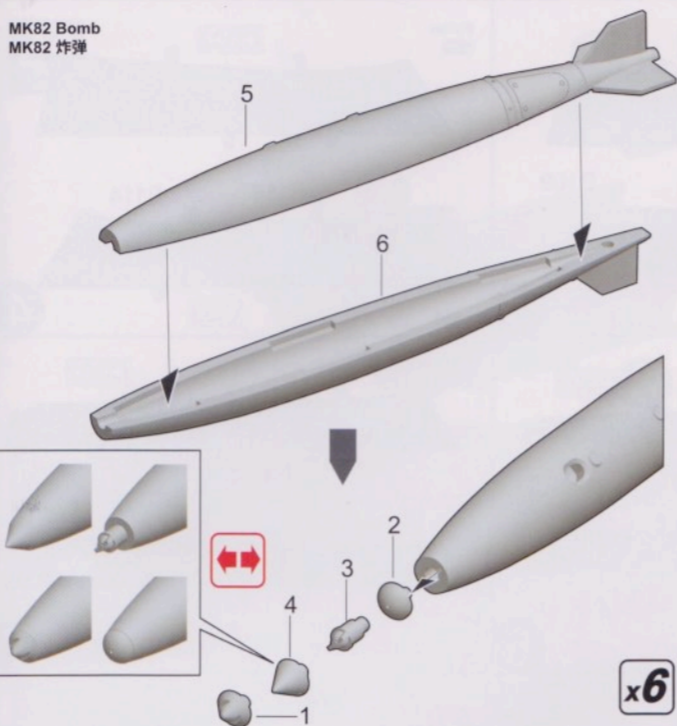

BRU-42 Pylon
BRU-42 挂架

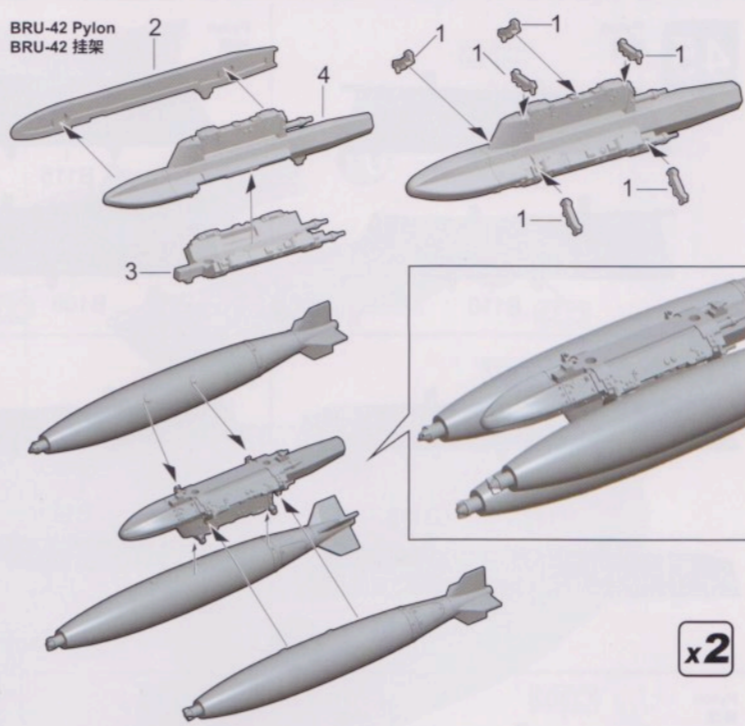

44

AIM-9L Missile
AIM-9L 导弹

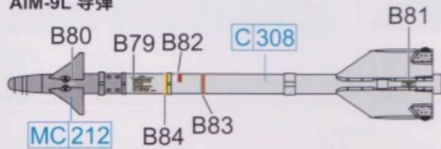

MK82 Bomb
MK82 炸弹



MK83 Bomb
MK83 炸弹



AGM-65 Maverick
小牛 空对地导弹

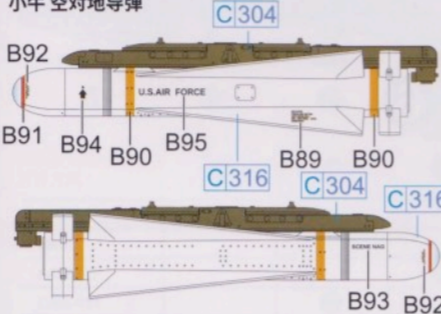

AN/ALQ-184 ECM POD
AN/ALQ-184 自卫式电子对抗(ECM)吊舱

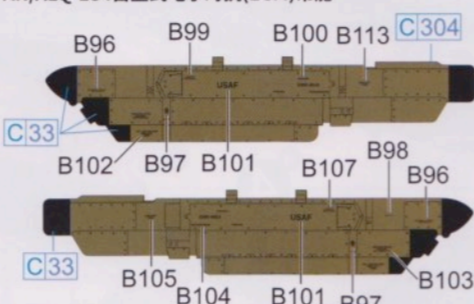

ALQ-131 ECM POD
ALQ-131 电子对抗(ECM)吊舱

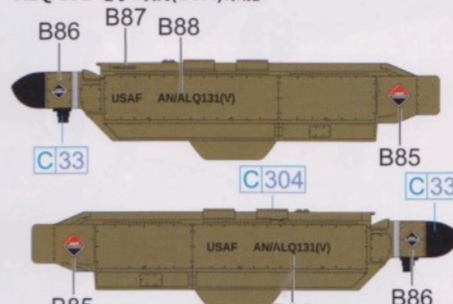

Twin Pylon
双联挂架



A-10 TANK
A-10 TANK 副油箱

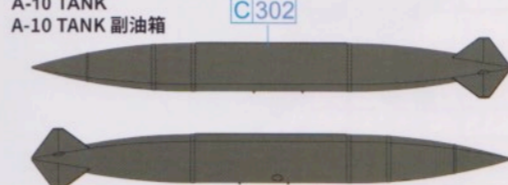

BRU-42 Pylon
BRU-42 挂架



LAU-131 Launcher
LAU-131 火箭巢

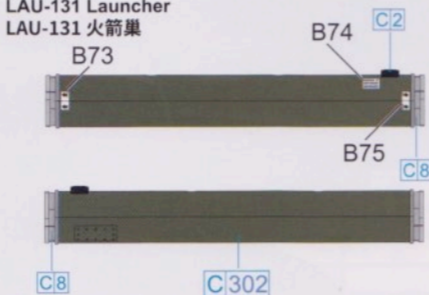

Pylon
挂架

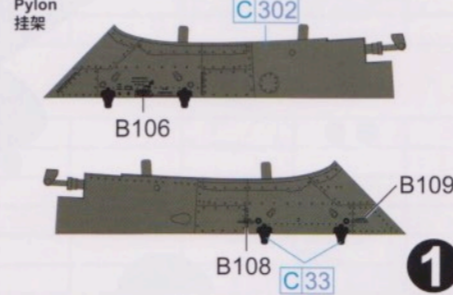

45

Pylon 挂架

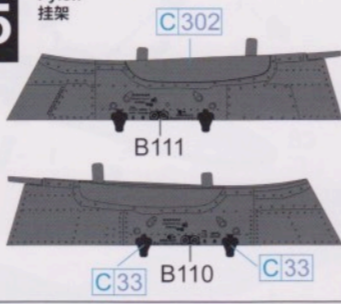

2

Pylon 挂架

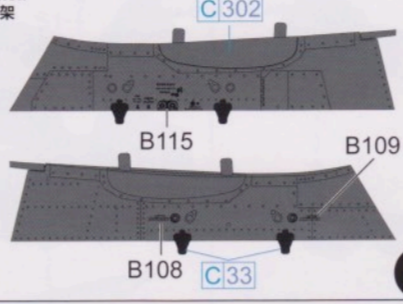

3

Pylon 挂架

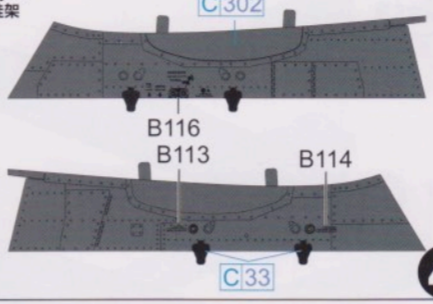

4

Pylon 挂架

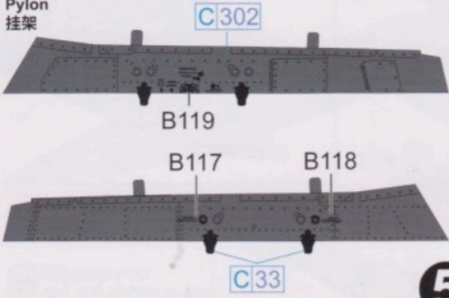

5

Pylon 挂架

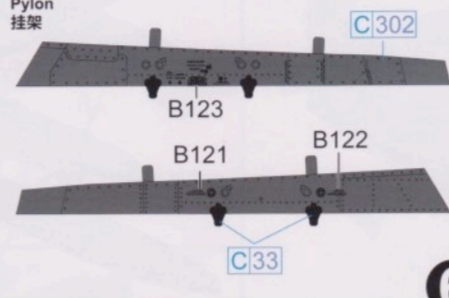

6

Pylon 挂架

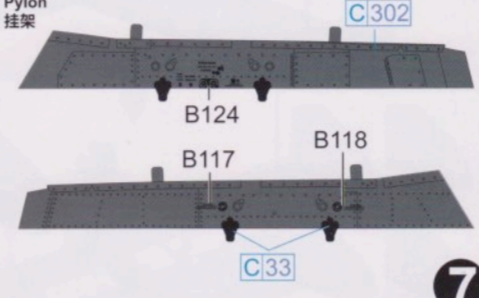

7

Pylon 挂架

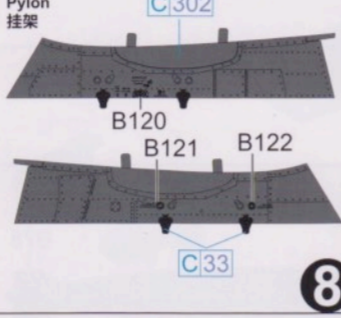

8

Pylon 挂架

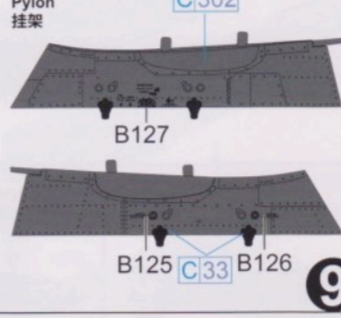

9

Pylon 挂架

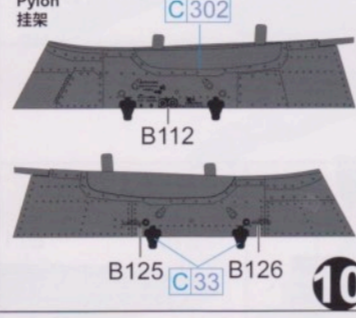

10

Pylon 挂架

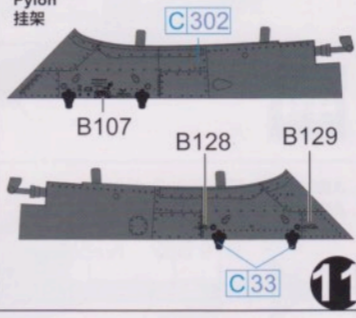

11

46

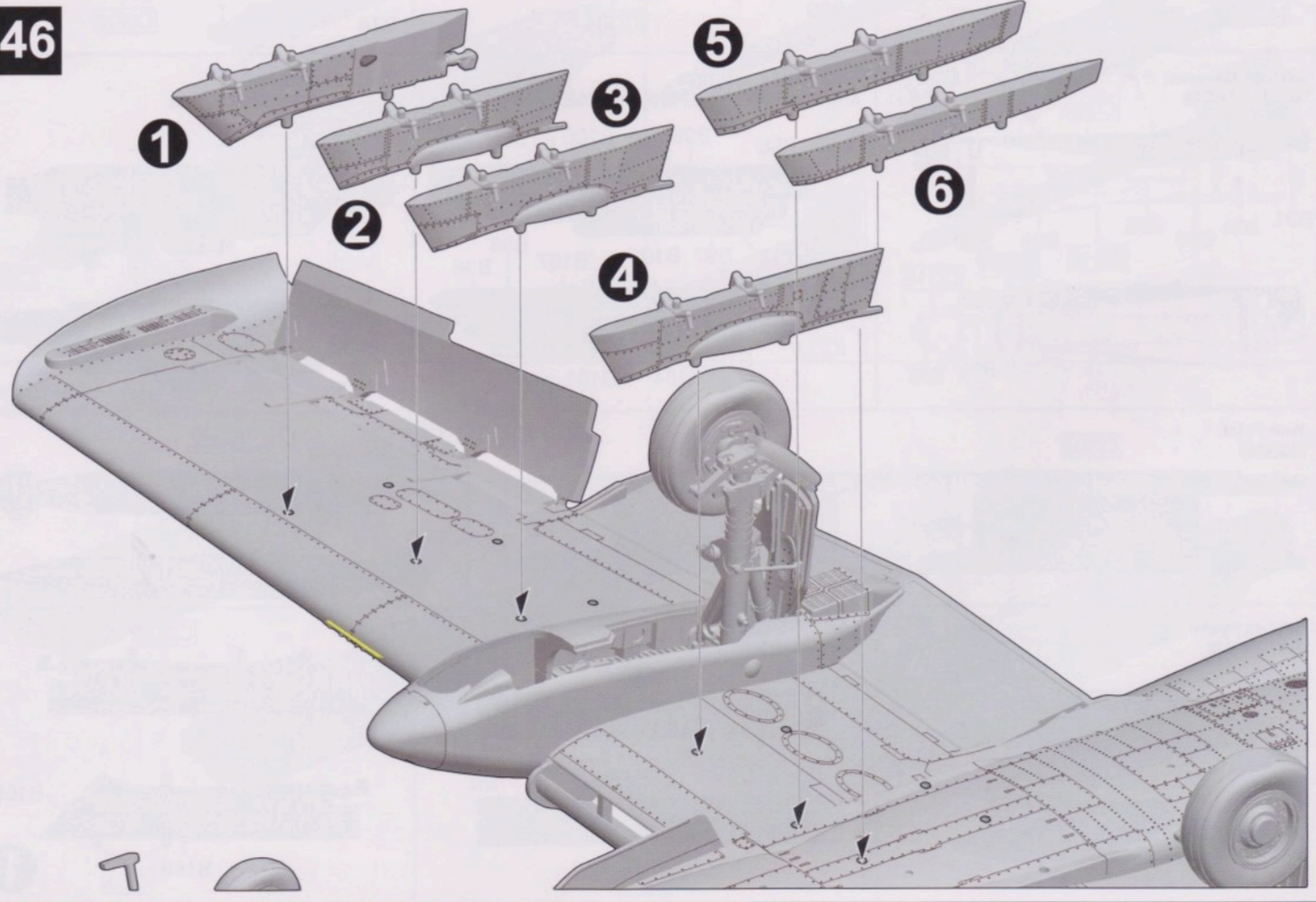

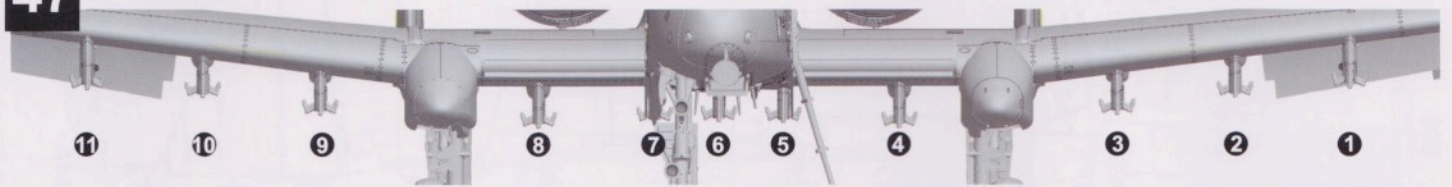
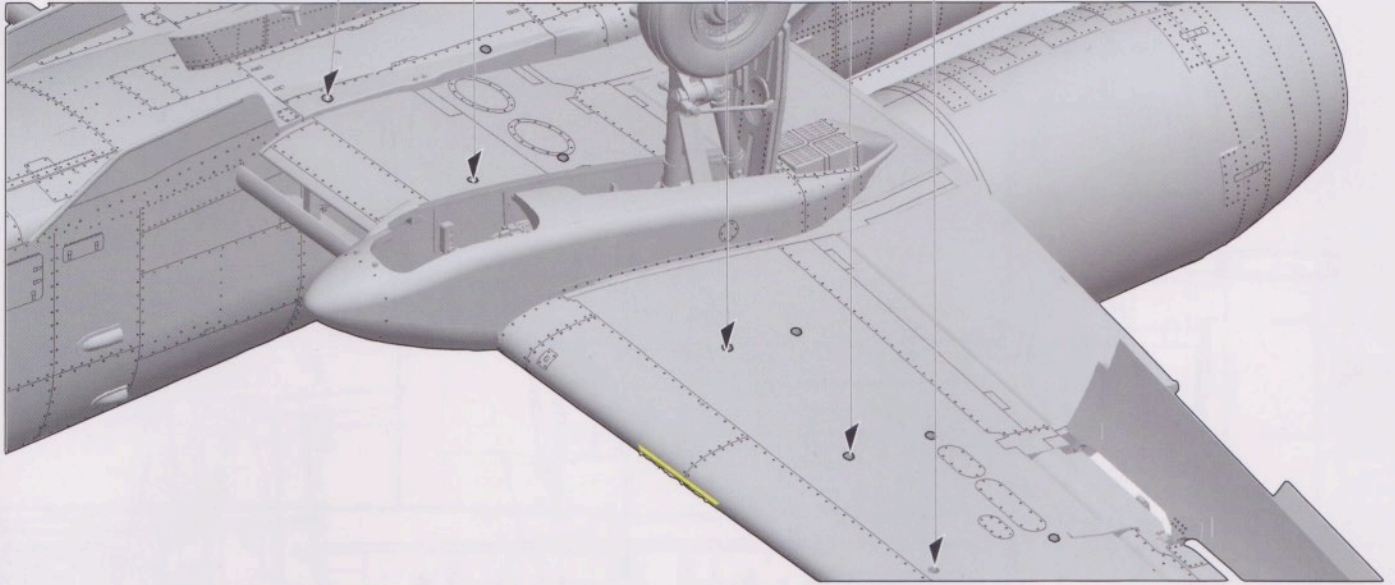
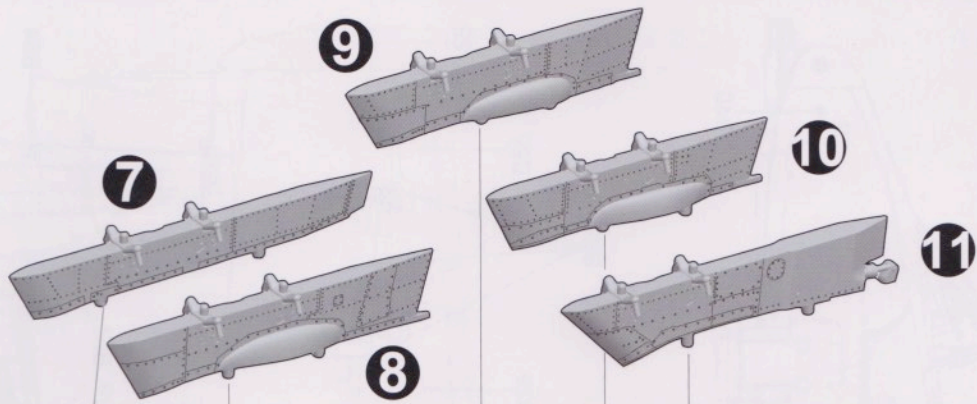

Weapon Ordnance 1
挂载方案 1

	11	10	9	8	7	6	5	4	3	2	1
AIM-9											● ●
Mk82				● ●	●		●	● ●			● ●
AGM-65			●						●		
LAU-131		●								●	
ALQ-184(2)	●										
A-10 TANK					●						

Weapon Ordnance 2
挂载方案 2

	11	10	9	8	7	6	5	4	3	2	1
AIM-9											● ●
Mk82				●	●	●	●	●			● ●
AGM-65			● ●						● ●		
LAU-131		●								●	
ALQ-184(2)	●										
A-10 TANK											

Weapon Ordnance 3
挂载方案 3

	11	10	9	8	7	6	5	4	3	2	1
AIM-9											● ●
Mk82				●				●			
Mk83					●		●				
AGM-65			●						●		
ALQ-131	●										
A-10 TANK					●						

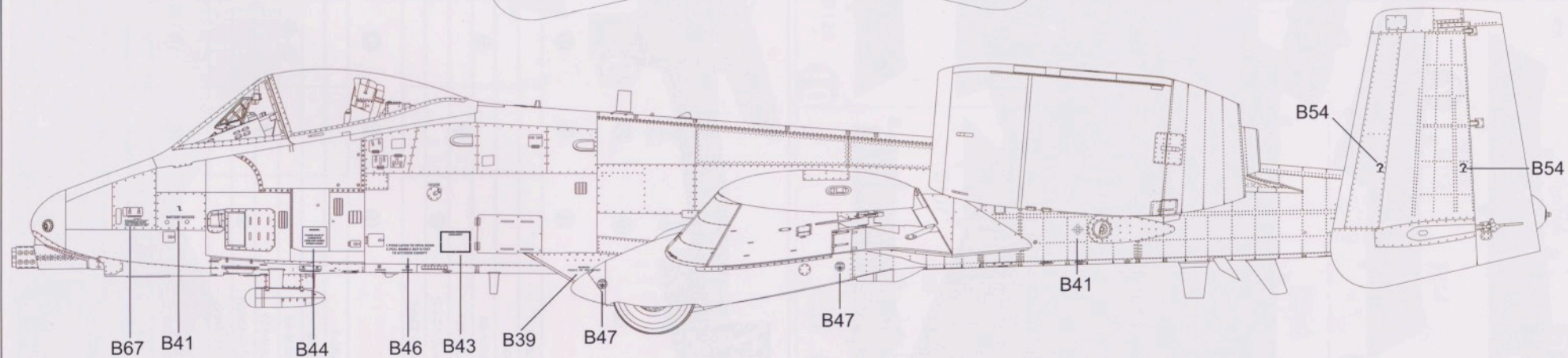
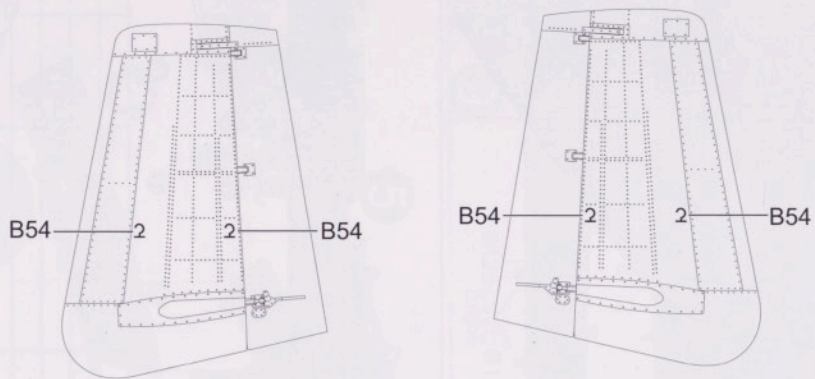
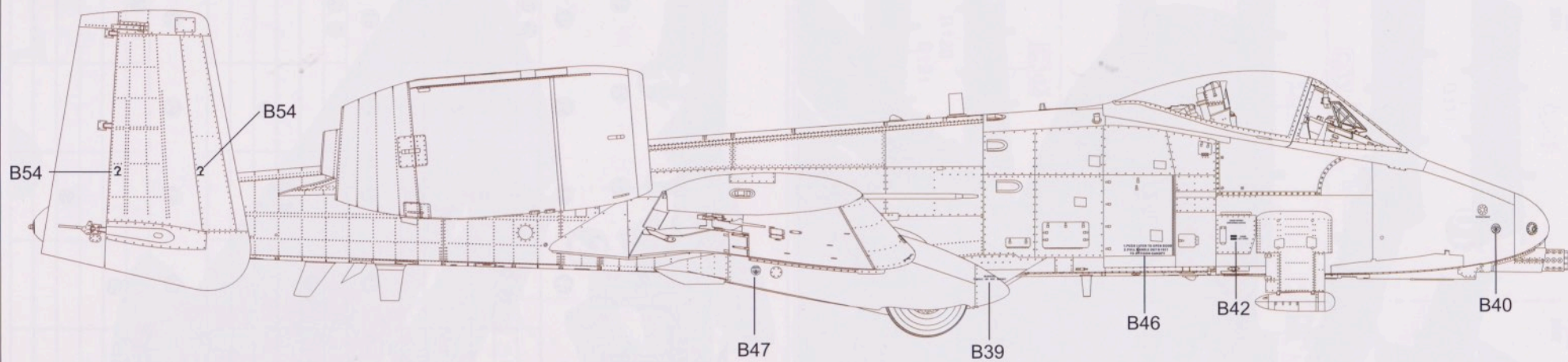

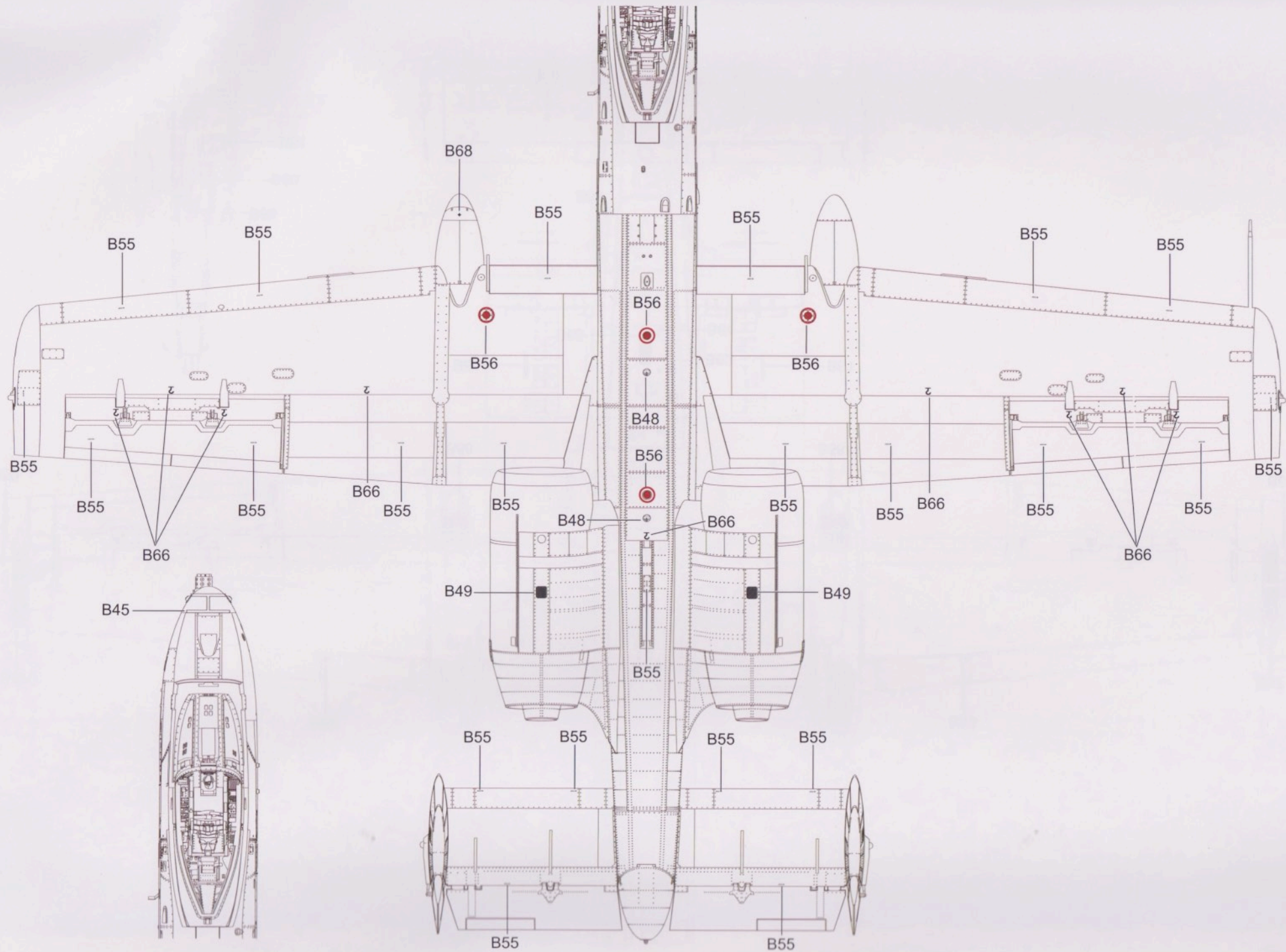

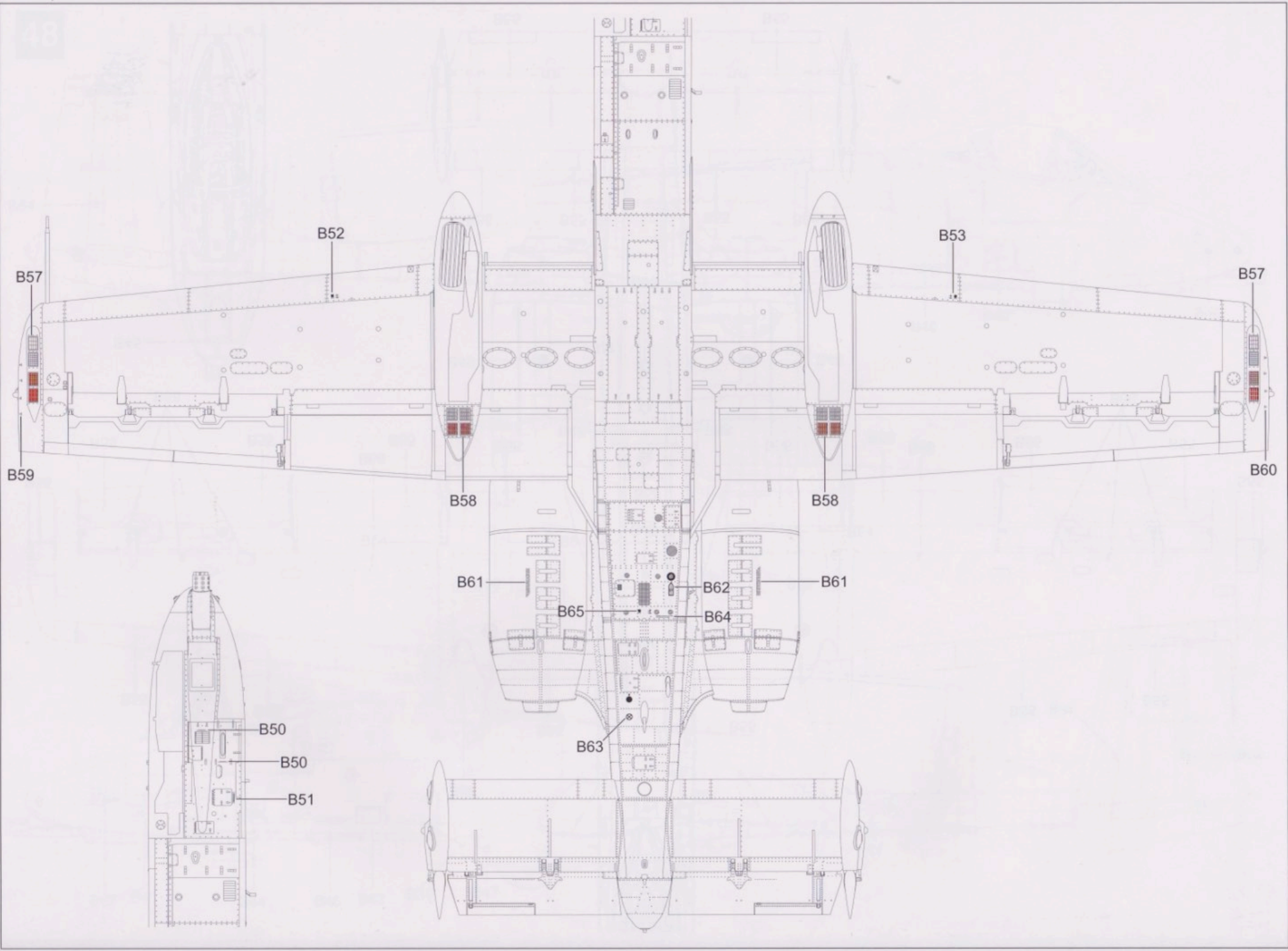



A-10A 雷电二式 近距离支援攻击机

THUNDERBOLT II

LOSE AIR SUPPORT ATTACK AIRCRAFT



A 78-0681 第353战术战斗机中队 沙特阿拉伯 第一次海湾战争 1991
78-0681 353rd Tactical Fighter Squadron, Saudi Arabia, Operation Desert Storm, 1991

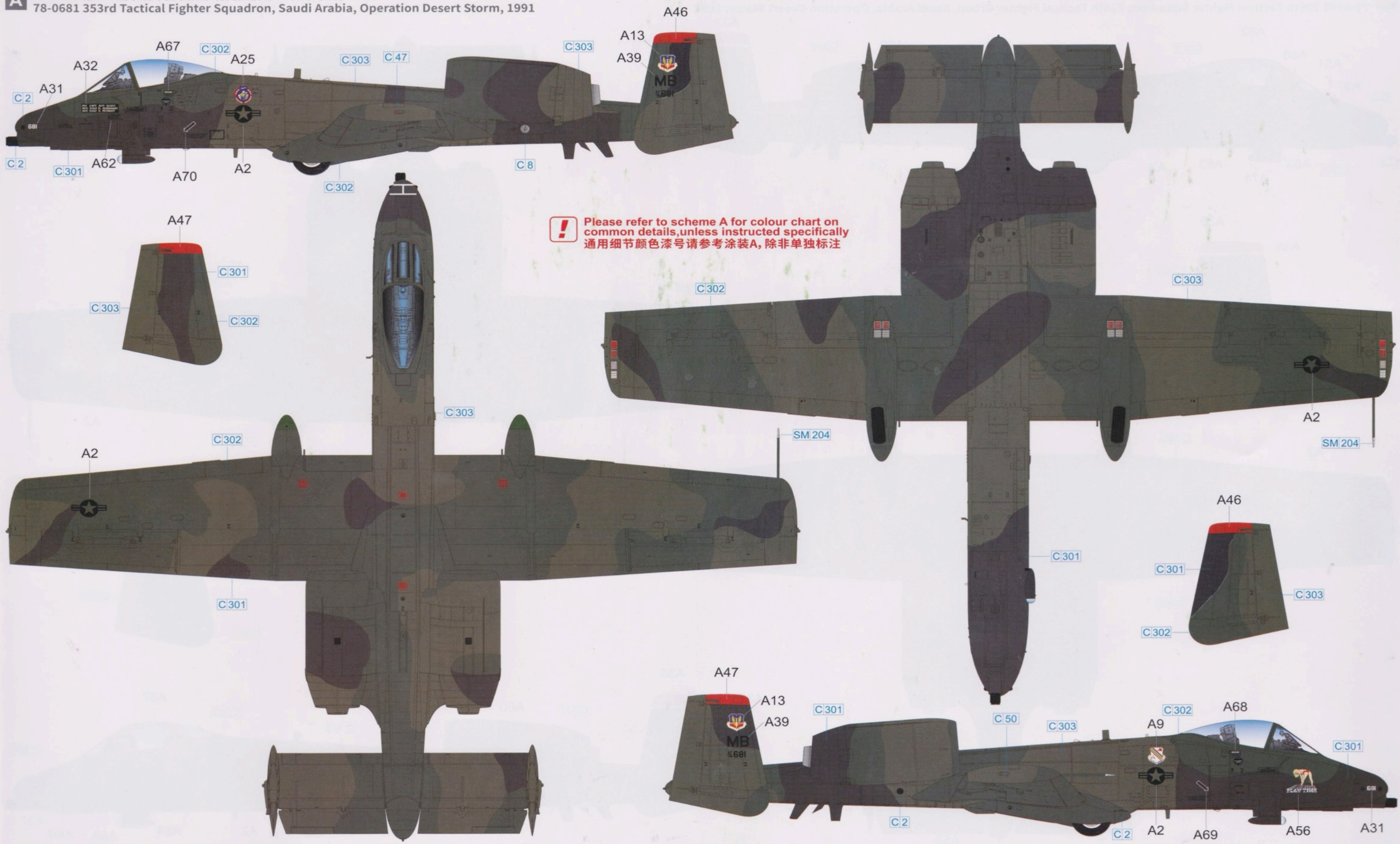

! Please refer to scheme A for colour chart on common details, unless instructed specifically
通用细节颜色漆号请参考涂装A, 除非单独标注



A-10A THUNDERBOLT II

雷電二式 近距离支援攻击机
CLOSE AIR SUPPORT ATTACK AIRCRAFT



B 77-0205 第926战术战斗机群 706战术战斗机中队 沙特阿拉伯 第一次海湾战争 1991
77-0205 706th Tactical Fighter Squadron, 926th Tactical Fighter Group, Saudi Arabia, Operation Desert Storm, 1991

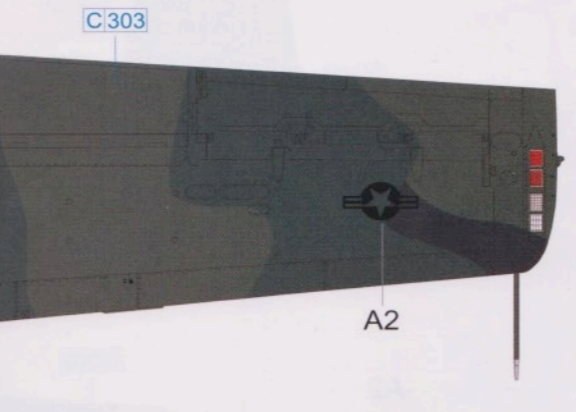
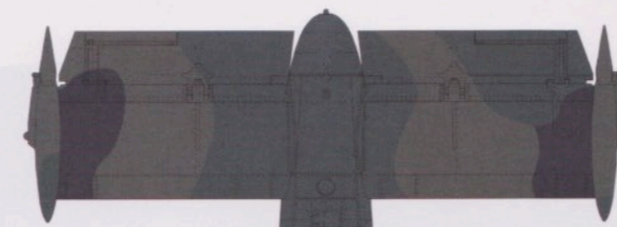
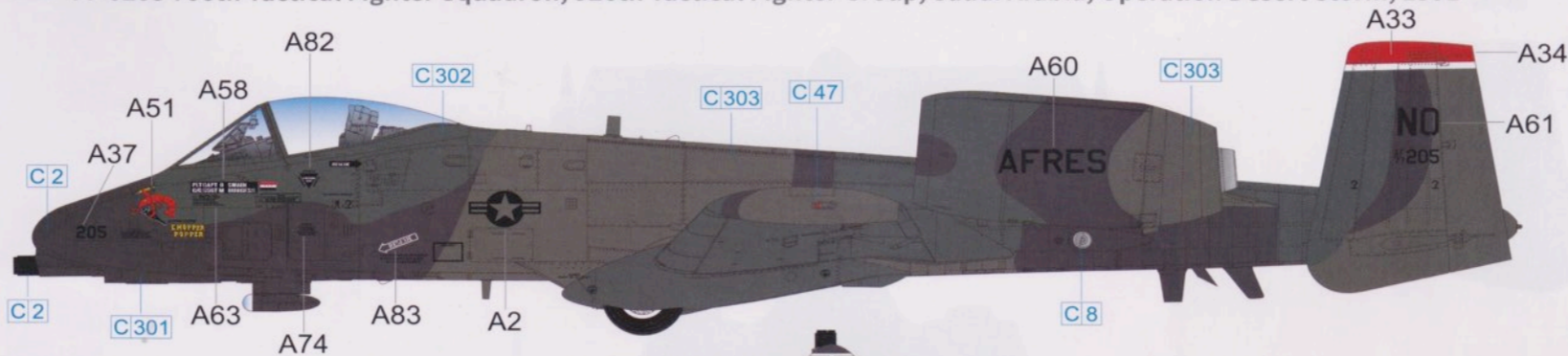

! Please refer to scheme A for colour chart on common details, unless instructed specifically
通用细节颜色漆号请参考涂装A, 除非单独标注

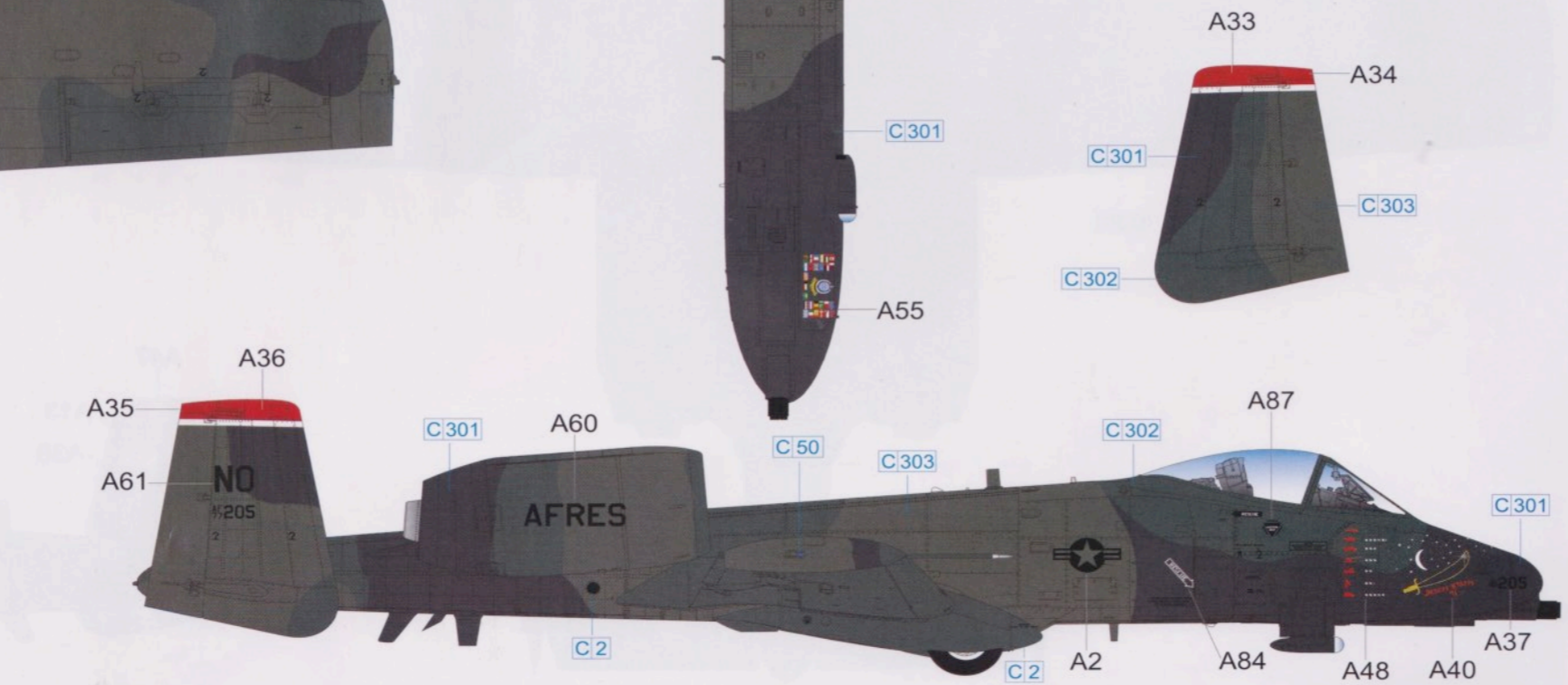
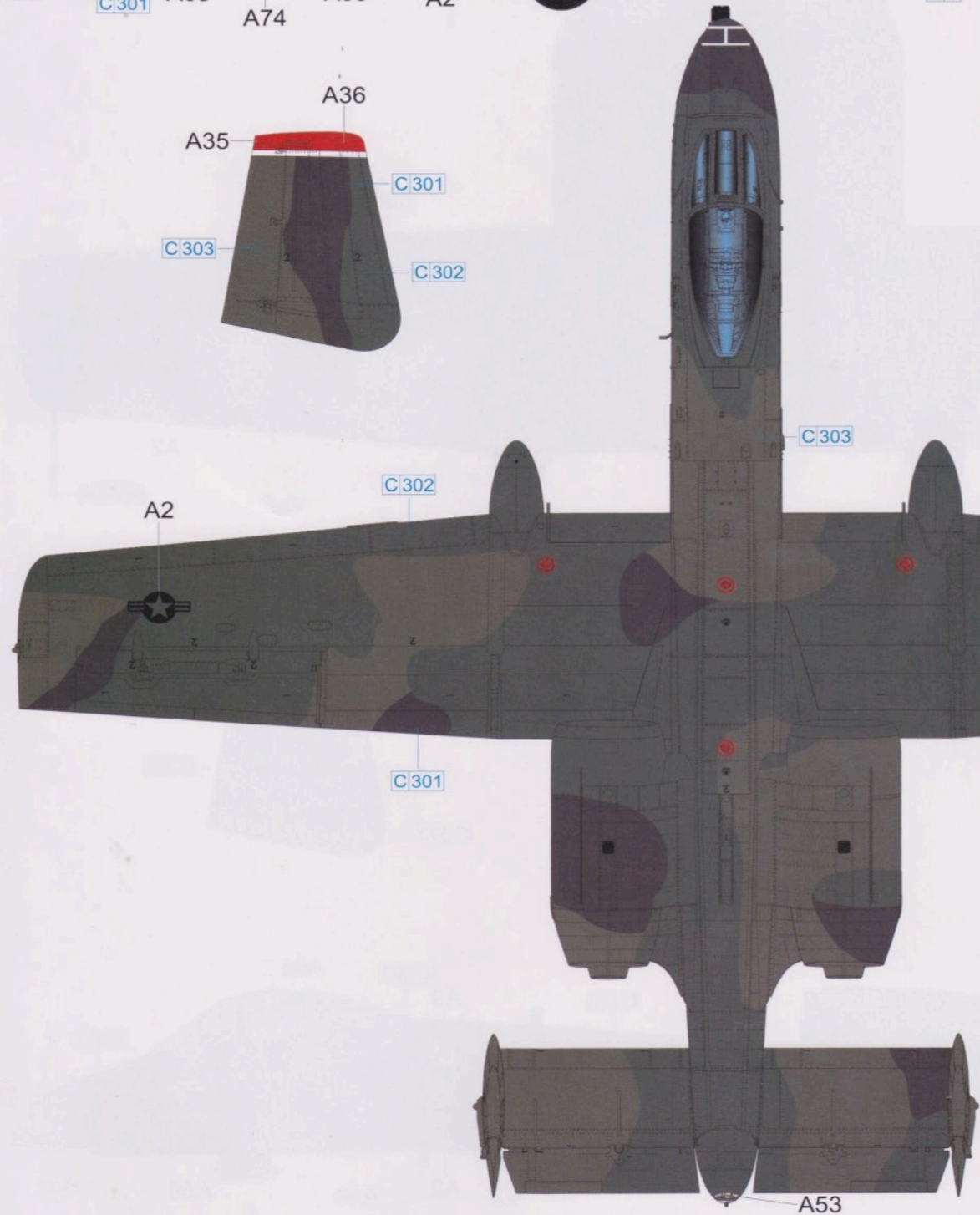



A-10A THUNDERBOLT II

雷電二式 近距离支援攻击机
CLOSE AIR SUPPORT ATTACK AIRCRAFT



1/48 SCALE AIR CRAFT L4825

涂装指示 PAINTING マーキングと塗装図

C 79-0176 第76战术战斗机中队 皇家空军 费尔福德空军基地 1989
79-0176 76th Tactical Fighter Squadron, RAF Fairford, 1989

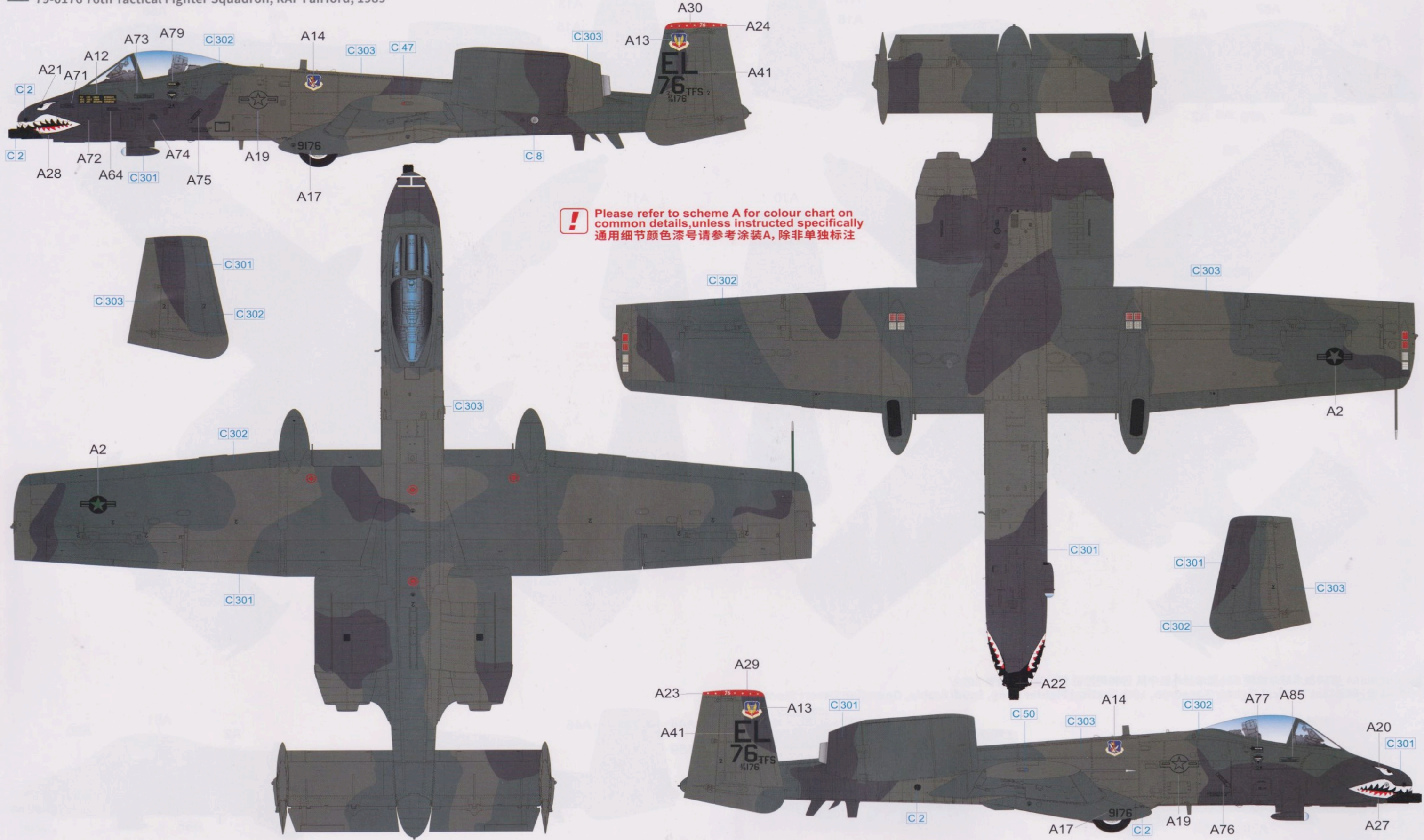



A-10A 雷电二式 近距离支援攻击机

THUNDERBOLT II

LOSE AIR SUPPORT ATTACK AIRCRAFT



D 79-0112 第355战术战斗机中队 沙特阿拉伯 第一次海湾战争 1991
79-0112 355th Tactical Fighter Squadron, Saudi Arabia, Operation Desert Storm, 1991

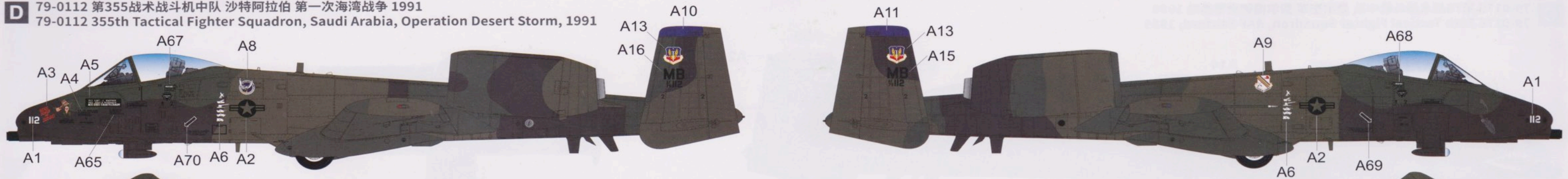

! Please refer to scheme A for colour chart on common details, unless instructed specifically
通用细节颜色漆号请参考涂装A, 除非单独标注

E 81-0964 第10战术战斗机群 511战术战斗机中队 沙特阿拉伯 第一次海湾战争 1991
81-0964 511st Tactical Fighter Squadron, 10th Tactical Fighter Wing, Saudi Arabia, Operation Desert Storm, 1991

