

TIGER I MID-PRODUCTION w/Zimmerit

Sd.Kfz.181 Pz.Kpfw.VI Ausf.E Otto Carius

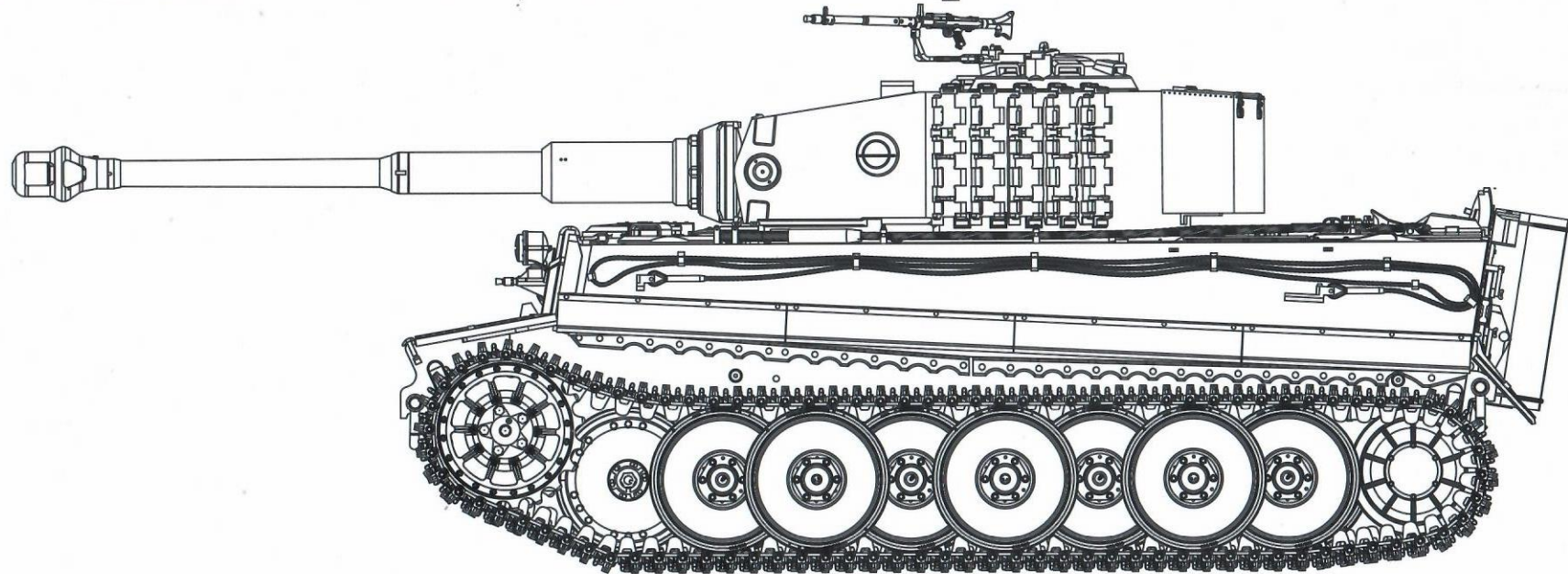

The legendary Tiger tank was arguably Nazi Germany's most feared weapon on the battlefields of Europe & North Africa during WWII. With its heavy armor and powerful cannon, the massive Tiger easily dominated most confrontations against its opponents. The mere sight of a Tiger often terrorized Allied troops without firing a shot. Nevertheless, the mighty Tiger suffered its own share of shortcomings, and Allied forces eventually learned how to defeat it in combat.

In the years leading up to WWII, the Germans began studying heavier tank designs to defeat the heavy French Char 2C and B1 tanks. These studies ultimately led to the development of the VK 36.01 prototype (built by Henschel) and the VK 45.01 prototype (built by Porsche). By this time, the Germans had been humiliated on the Eastern Front by the Soviet T-34 & KV-1 tanks, which proved the necessity for a heavier tank. After much competition and many changes along the way, the winner of the contract for a production vehicle was awarded to Henschel, whereas the Porsche prototypes were used to make the Sd.Kfz.182 Elefant/Ferdinand tank destroyers. Production of the Sd.Kfz.181 Tiger I began in May 1942 and lasted until August 1944, with continuous modifications & improvements being made throughout the entire production of 1347 units.

The Tiger I was armed with the formidable Krupp 88mm KwK 36 L/56 main gun, which was derived from the proven 88mm Flak 18 and Flak 36 guns. It primarily fired PsGr.39 Armor Piercing, Capped, Ballistic Capped (APCBC) shells at a muzzle velocity of 780 meters per second and Pz.Gr.40 Armor-Piercing Composite Rigid (APCR) shells at a muzzle velocity of 930 meters per second, with a range of 10,500 meters. The gun could be reloaded in around 11 seconds, resulting in a potential rate of fire of approximately 6 rounds per minute. An MG 34 was mounted coaxially with the main gun, a second mounted in the bow, and a third mounted externally on the commander's cupola.

Five men crewed the Tiger I, consisting of the commander, gunner, and loader in the turret, and the driver and radio operator in the front of the hull. The 56-ton tank was initially powered by the Maybach HL 210 TRM P45 21-liter V-12 engine producing 650 hp, but this was later replaced by the more powerful Maybach HL 230 TRM P45 23-liter V-12 engine producing 700 hp from May 1943. Armor protection consisted of 102mm thick homogenous steel plates at the front of the bow, 62mm thick armor plates on the lower hull sides, 82mm thick armor on the upper hull sides and turret sides, 97mm thick armor on the front of the turret (with up to 200mm thickness being added by the cast mantlet), 82mm thick armor on the rear hull, and 26mm thick armor on the floor and roof (with the roof thickness being increased to 40mm in September 1943).

Oberleutnant Otto Carius was a German tank commander during World War II and is credited with destroying more than 150 tanks. In 1943, Carius transferred to the schwere Panzer-Abteilung 502, which fought at the Leningrad front and then near Narva, Estonia. Carius was severely wounded on July 24, 1944 while reconnoitering a village on a motorcycle ahead of his tanks, but survived to surrender to the US Army on April 15, 1945.

03.02.2200

READ BEFORE ASSEMBLY

CAUTION

- Read carefully and fully understand the instructions before commencing assembly. A supervising adult should also read the instructions if a child assembles the model.
- When assembling this kit, tools including knives used. Extra care should be taken to avoid personal injury.
- Keep out of reach of small children. Children must not be allowed to suck any part, or pull vinyl bag over their heads.



Be Careful



Optional



Instant Glue for Metal



Remove



Drill



Do Not Cement

APPLYING DECALS

1. Clean the model surface with a wet cloth.
2. Cut out each decal design from sheet, and dip it in tepid water for 15~20 sec.
3. Hold the backing sheet edge and slide decal onto the model.
4. Move decal into position by wetting decal with finger.
5. Press decal gently down with a soft cloth until excess water and air bubbles are gone.

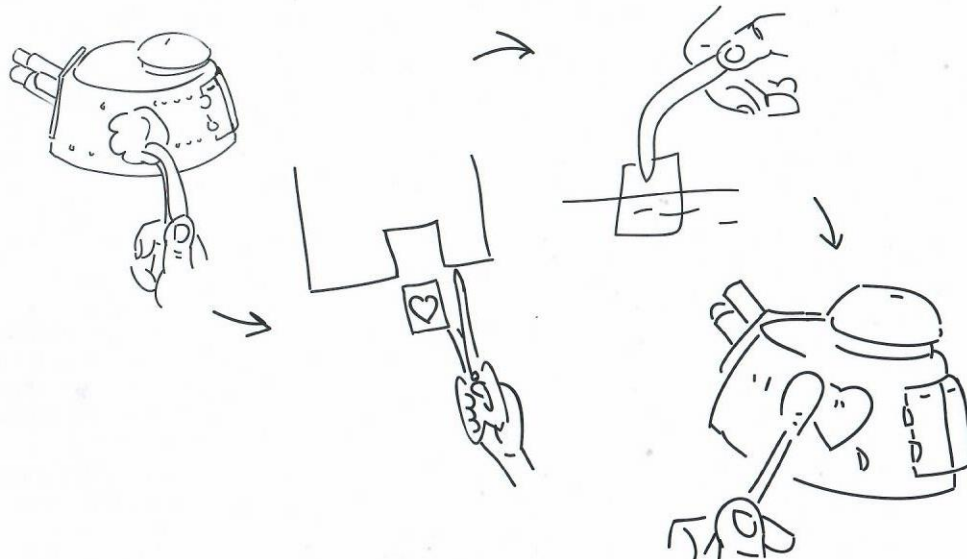

REMOVING PE

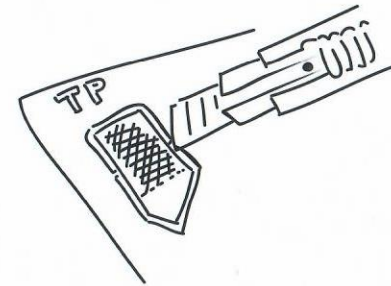

Be careful not to hurt when removing PE parts.

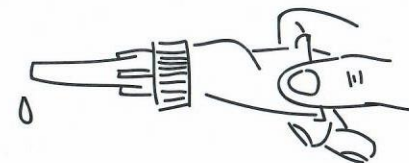

Secure using instant glue (not included).



Finish using file.

PARTS

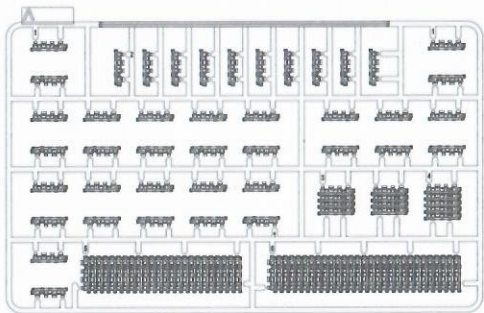

X2

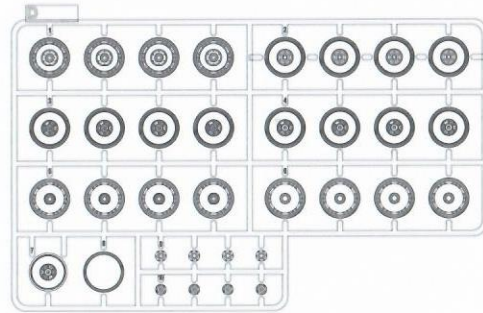
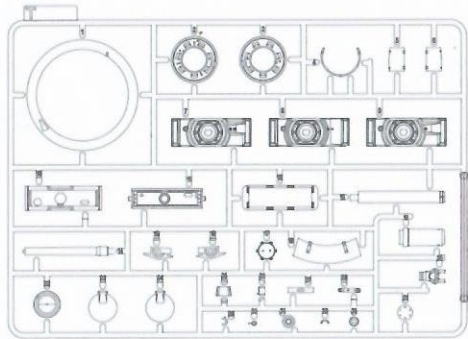

X2

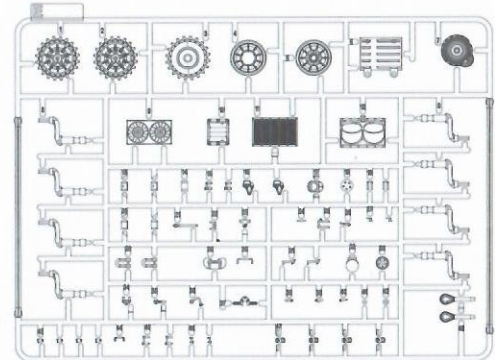

X2

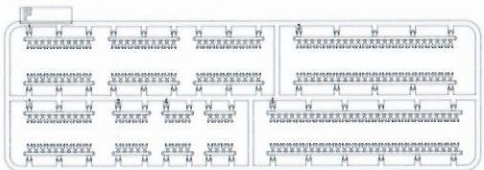
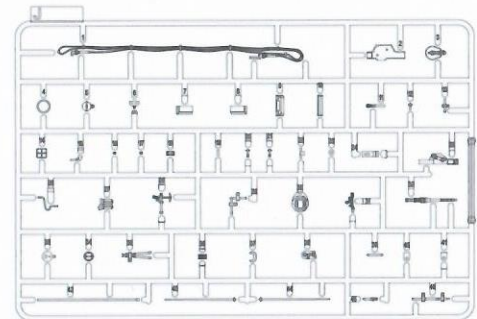
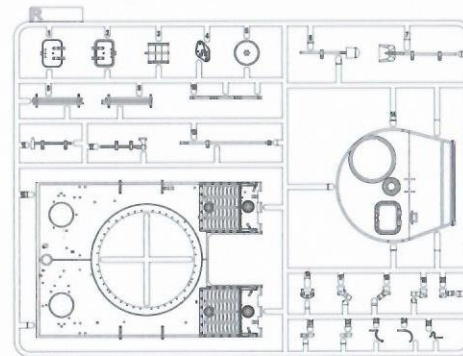
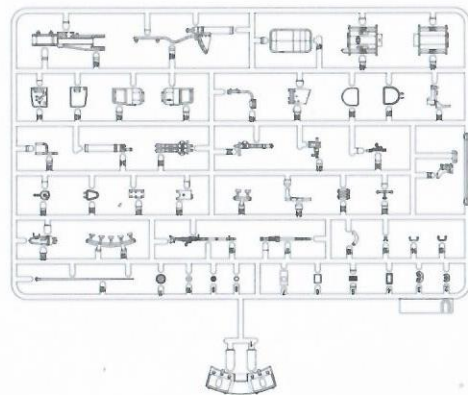
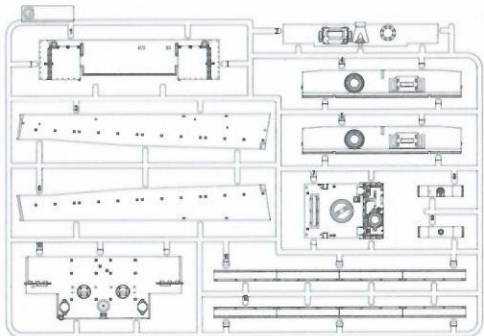

X2

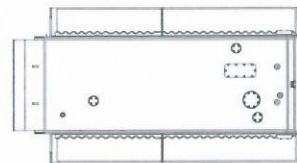
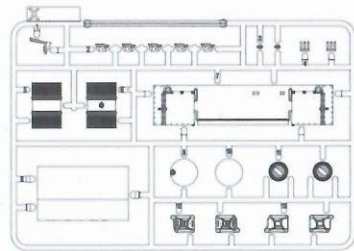

Q



N



TP

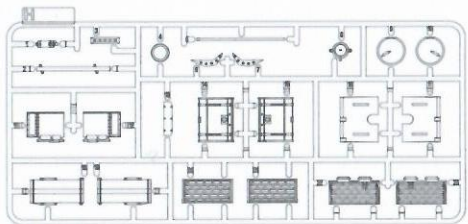

Metal Barrel

Cable

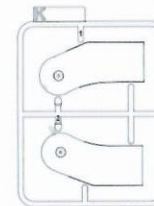
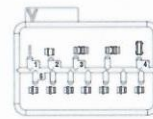

Decal

1

A

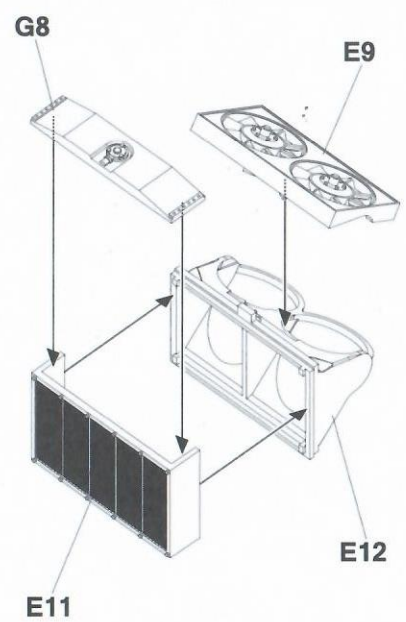
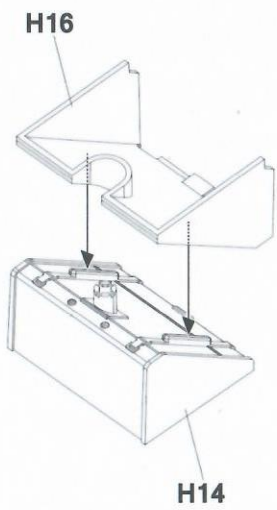

B

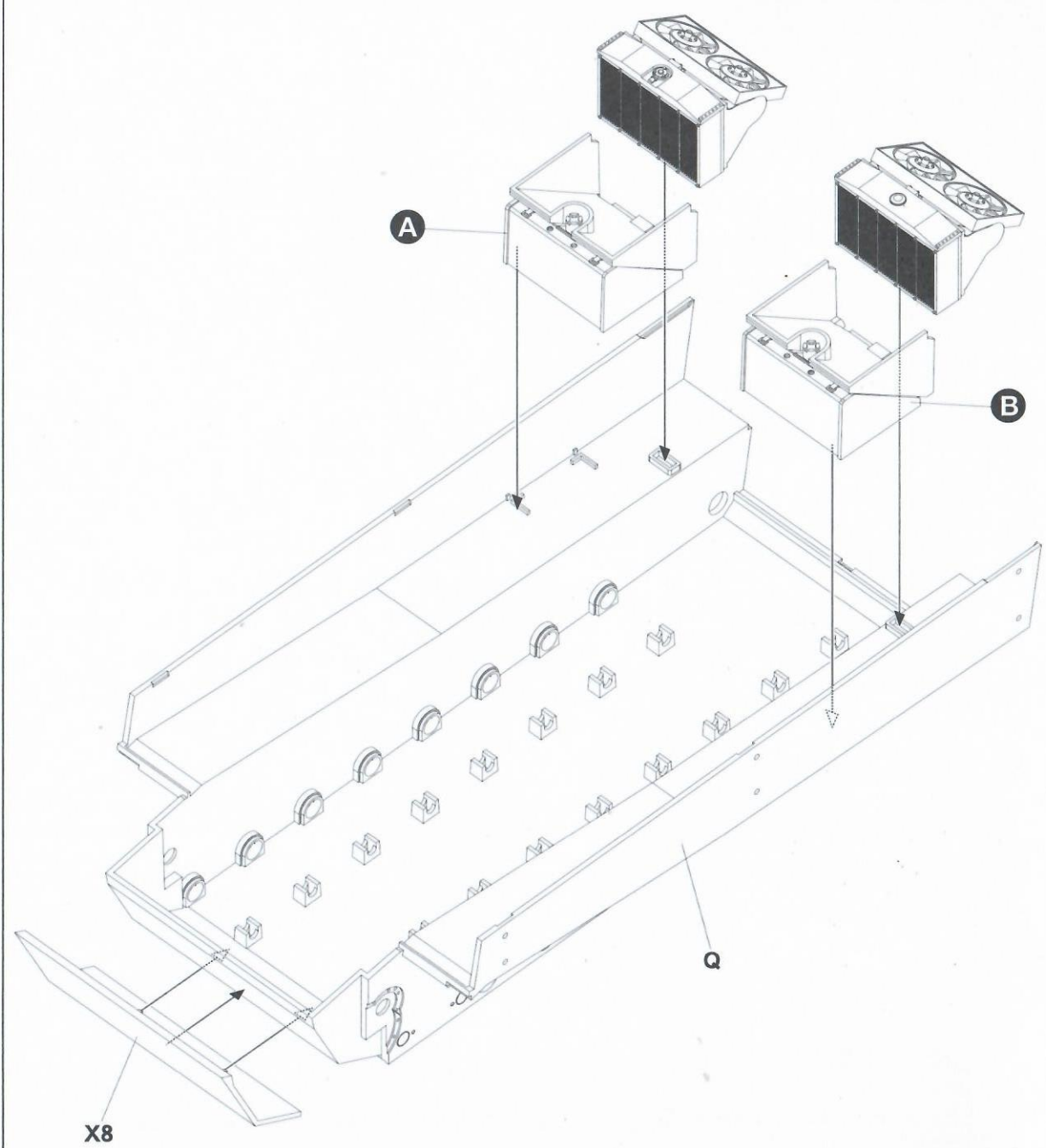
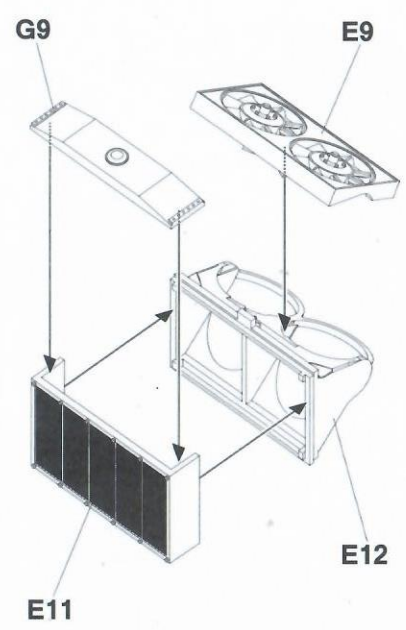
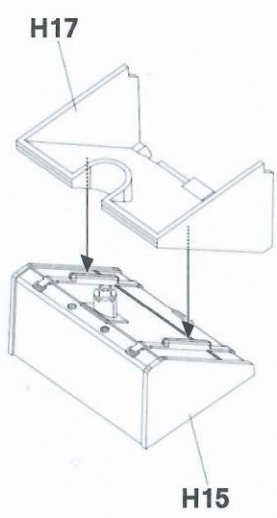

3

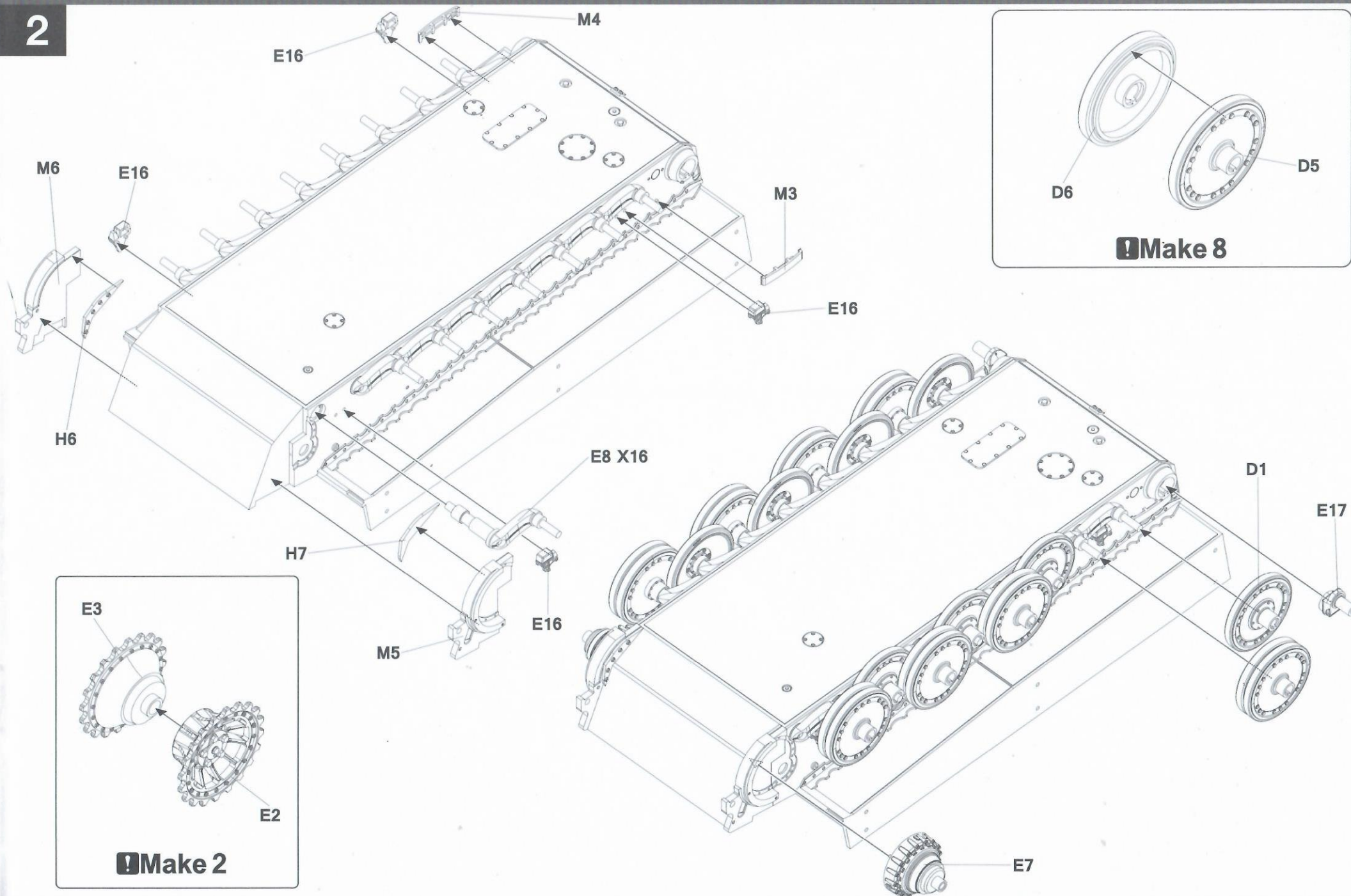

3

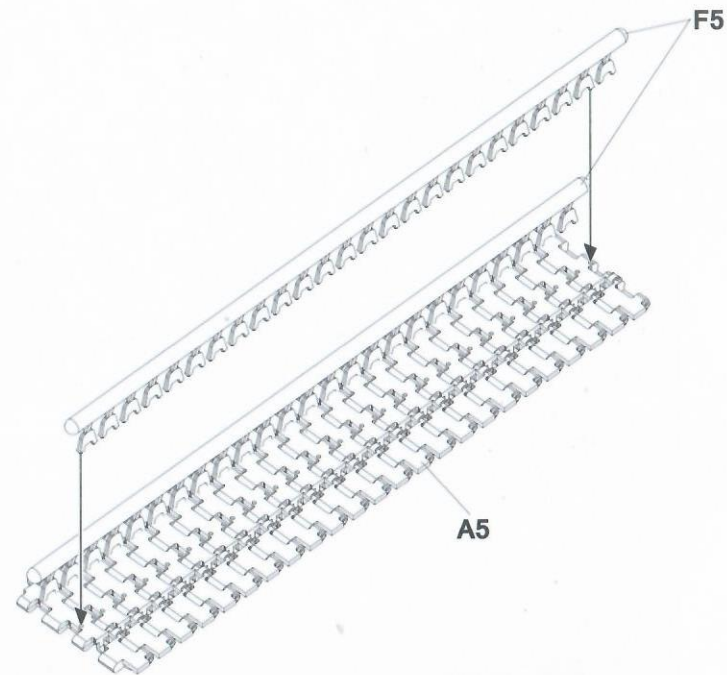
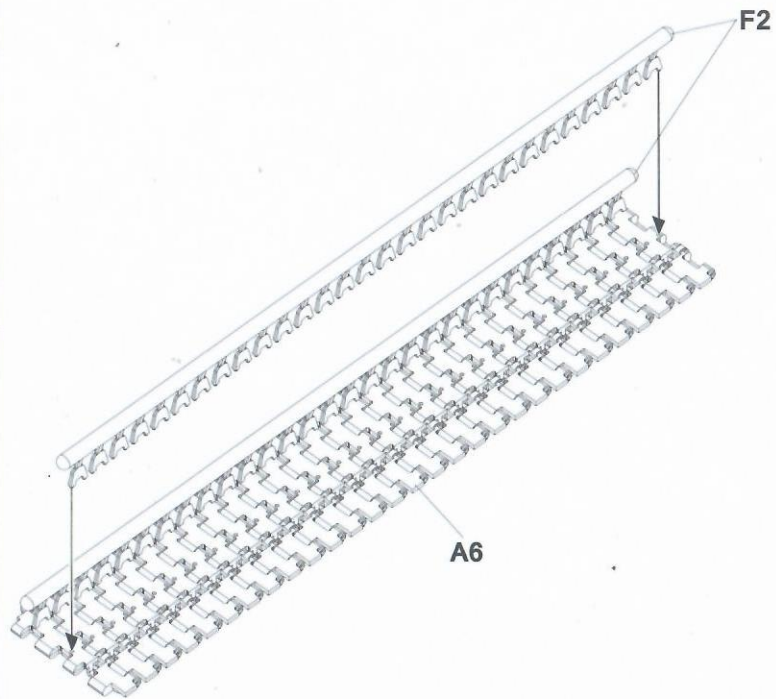
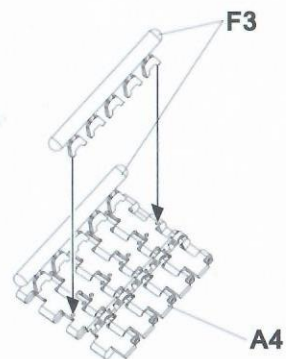
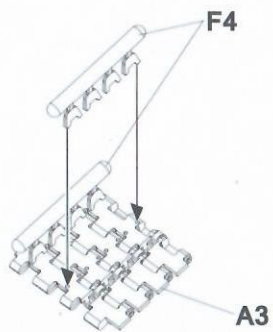
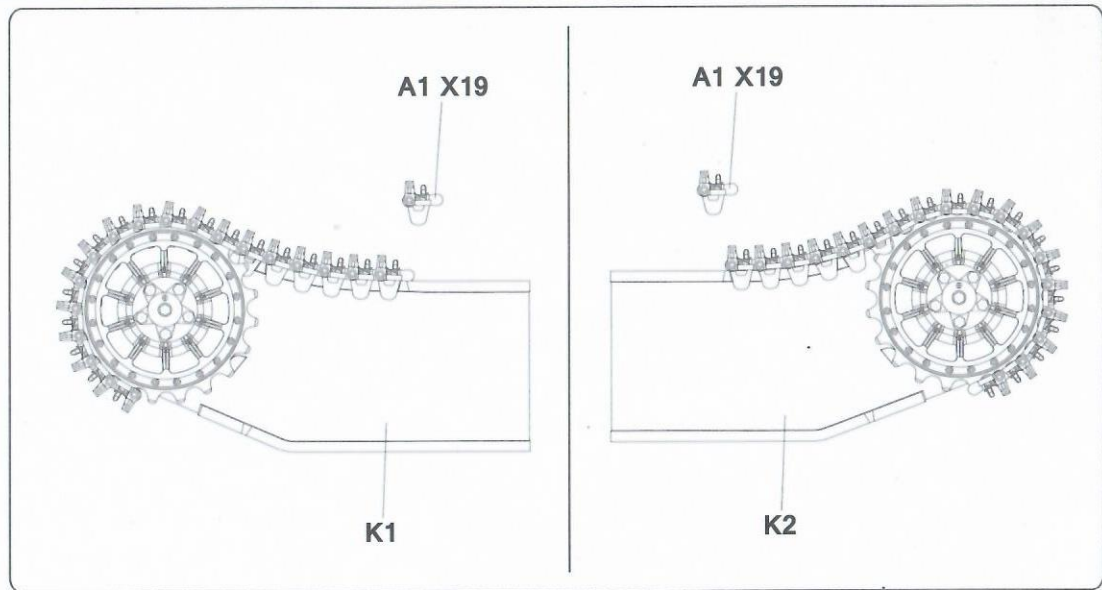
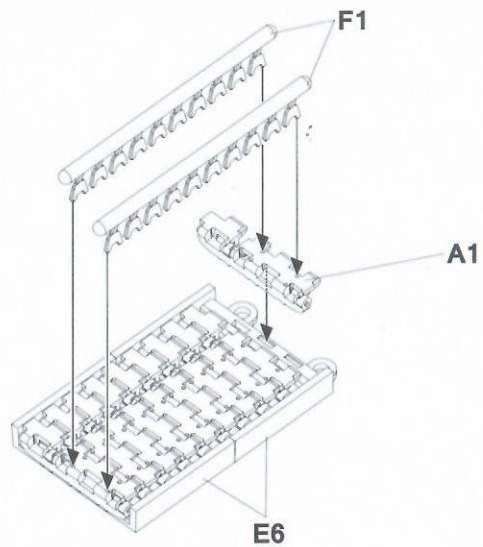
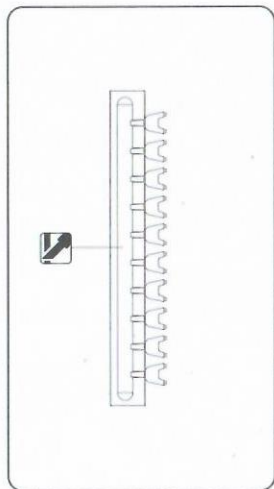

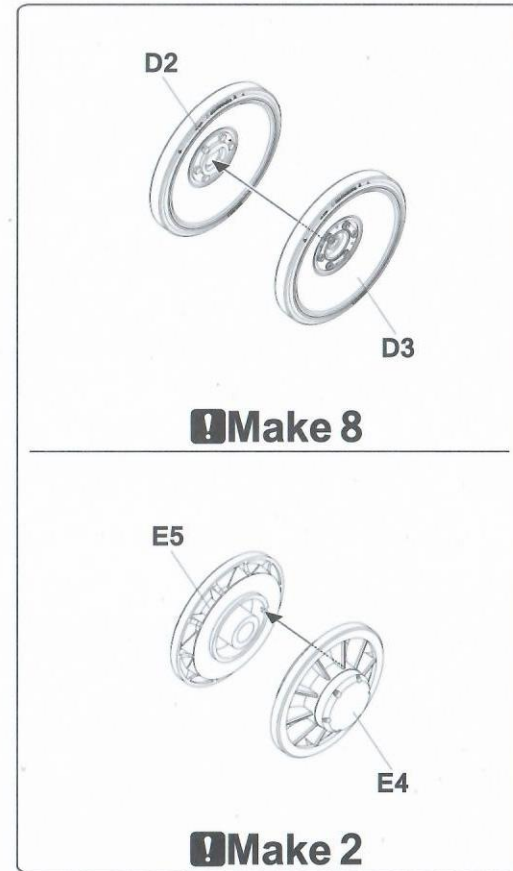
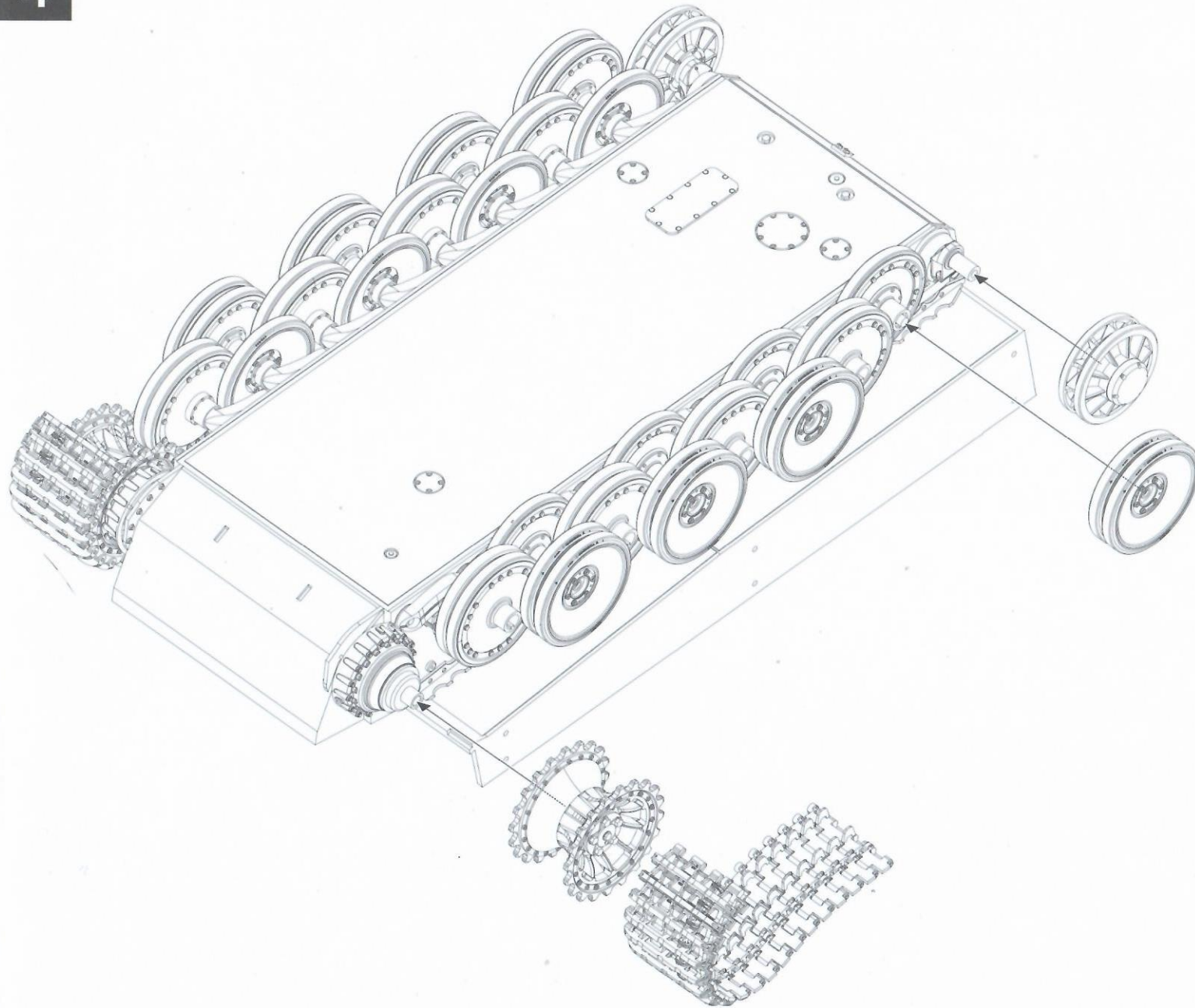

5

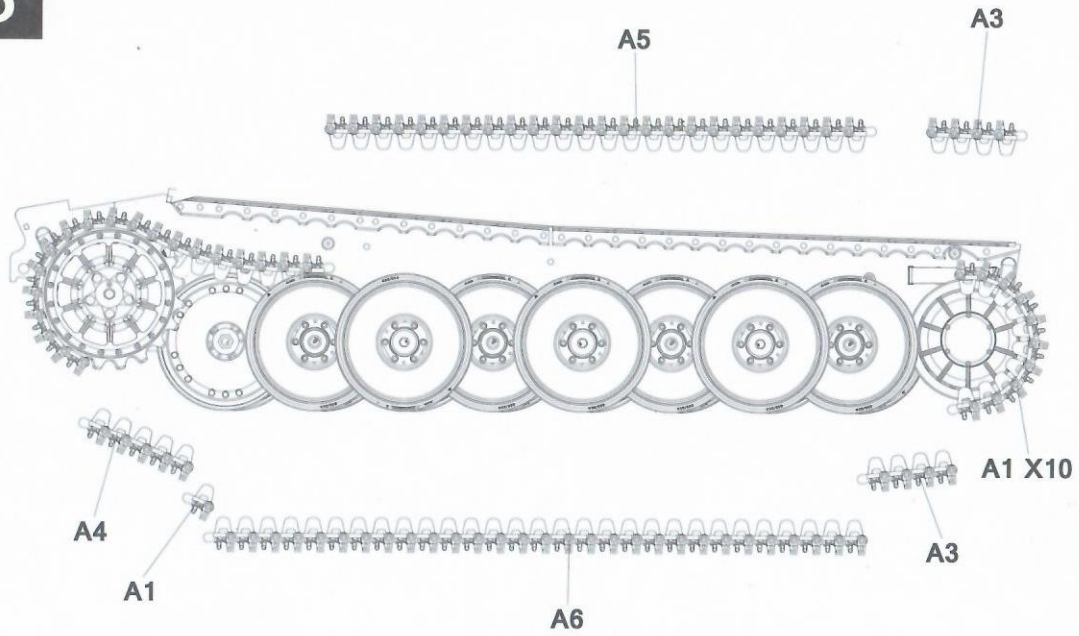

6

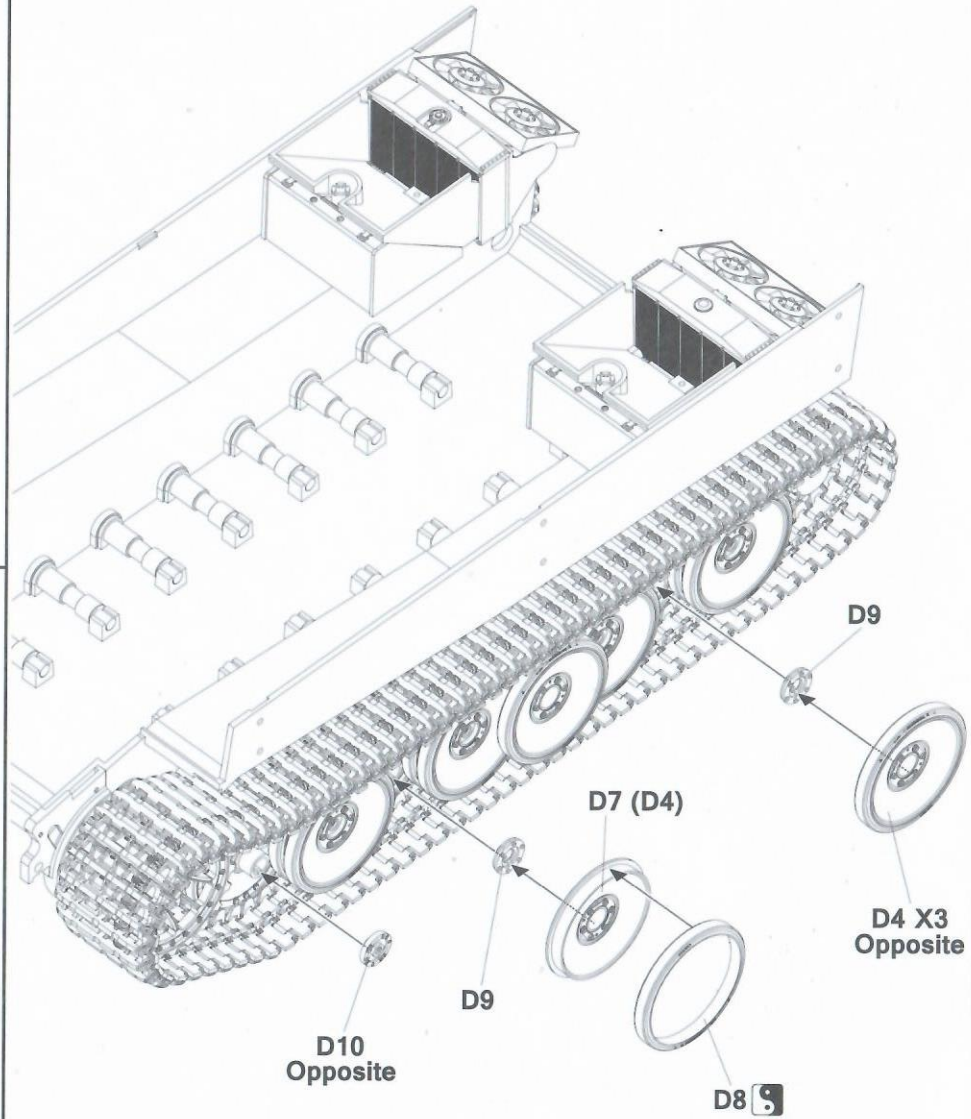

7

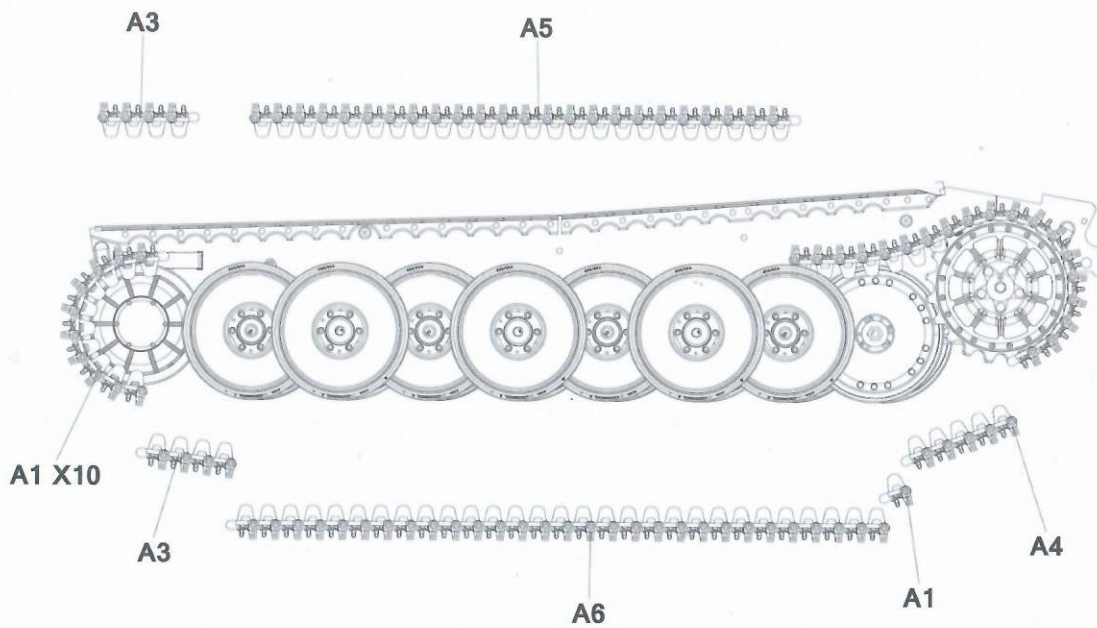

7

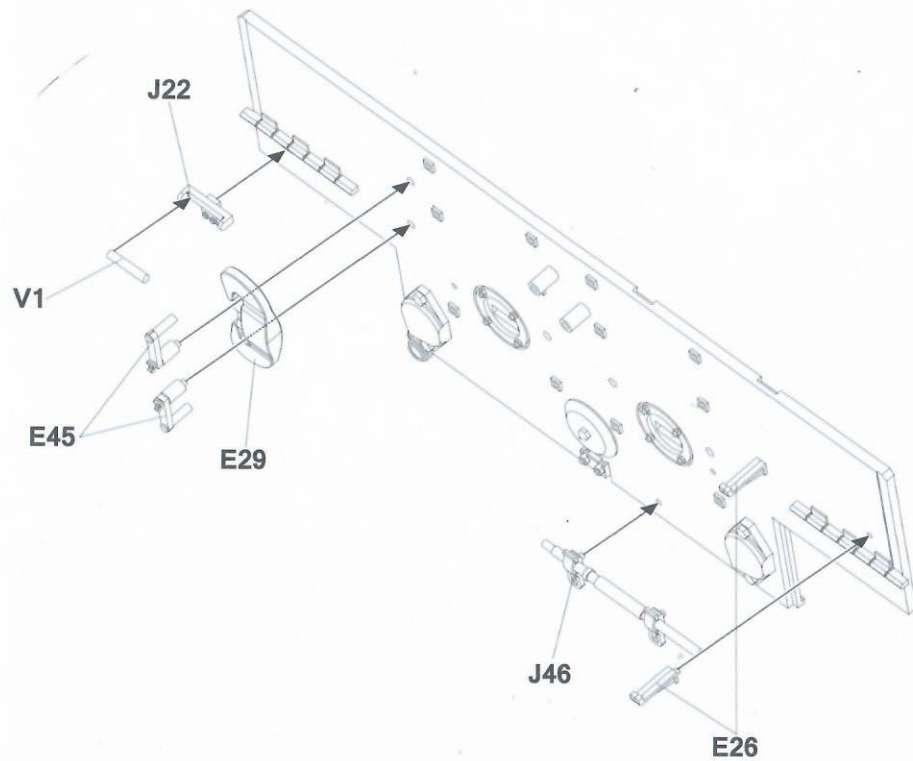
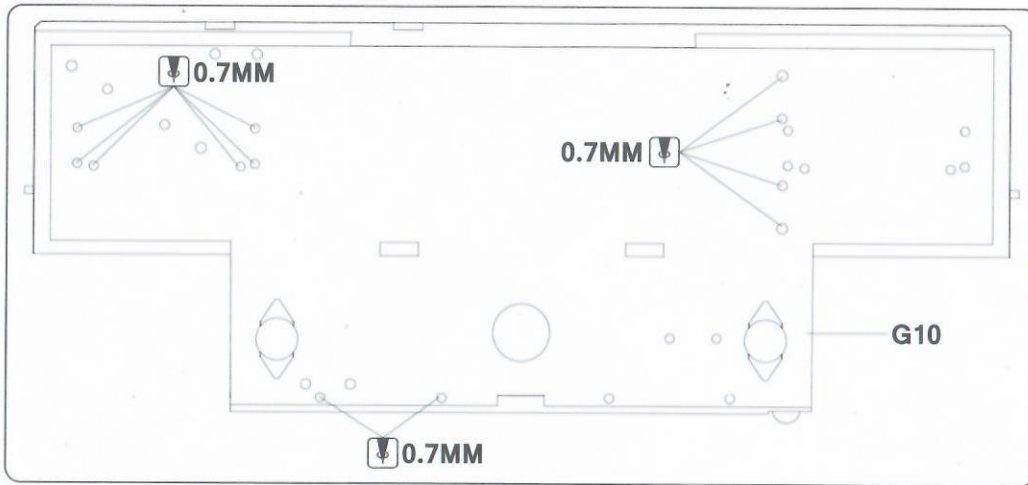

8

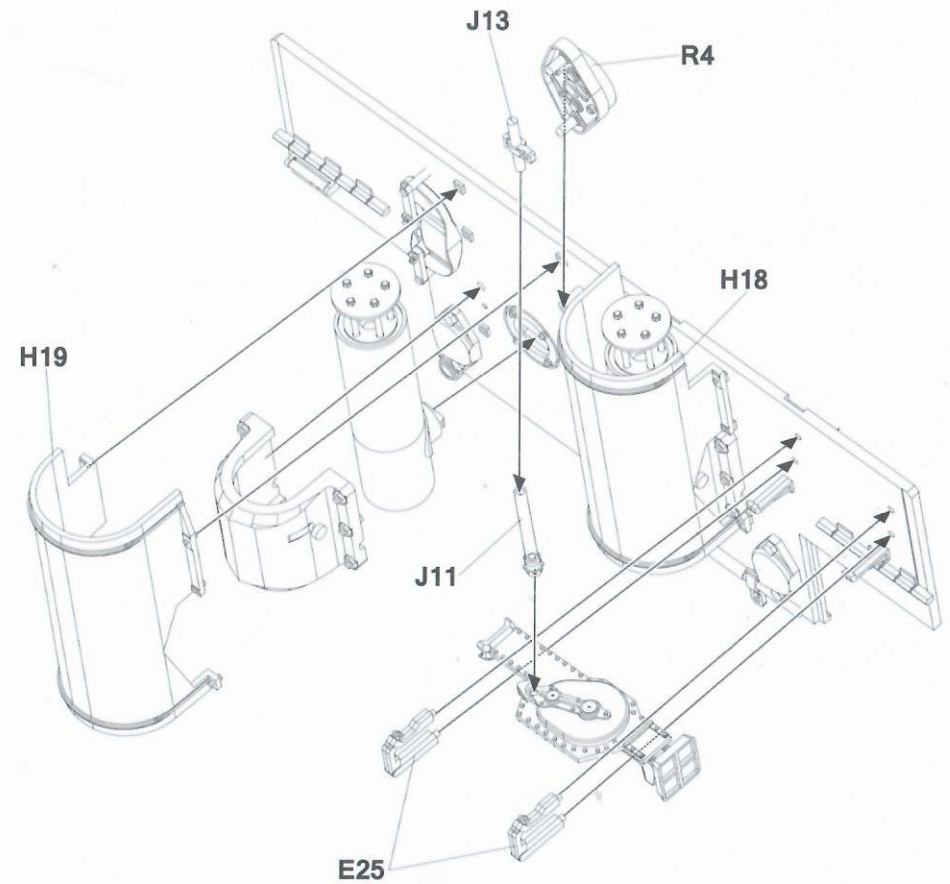
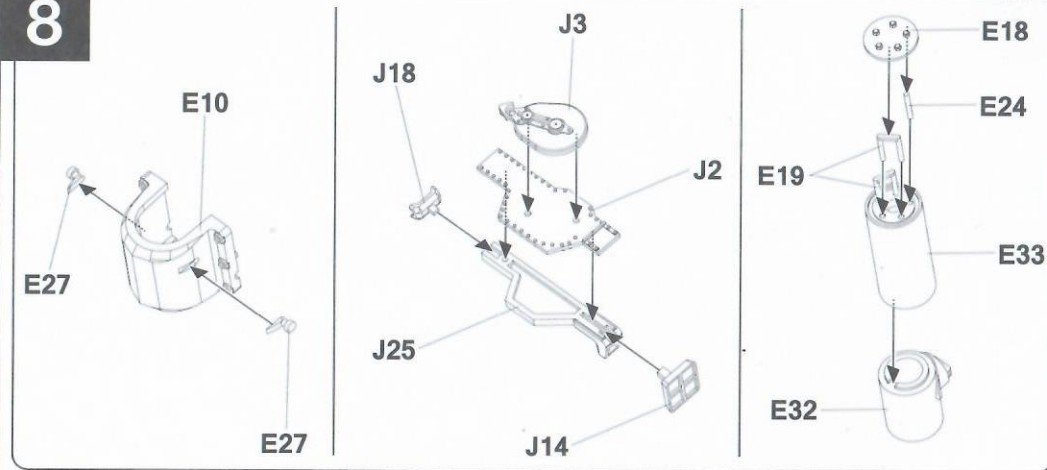

8

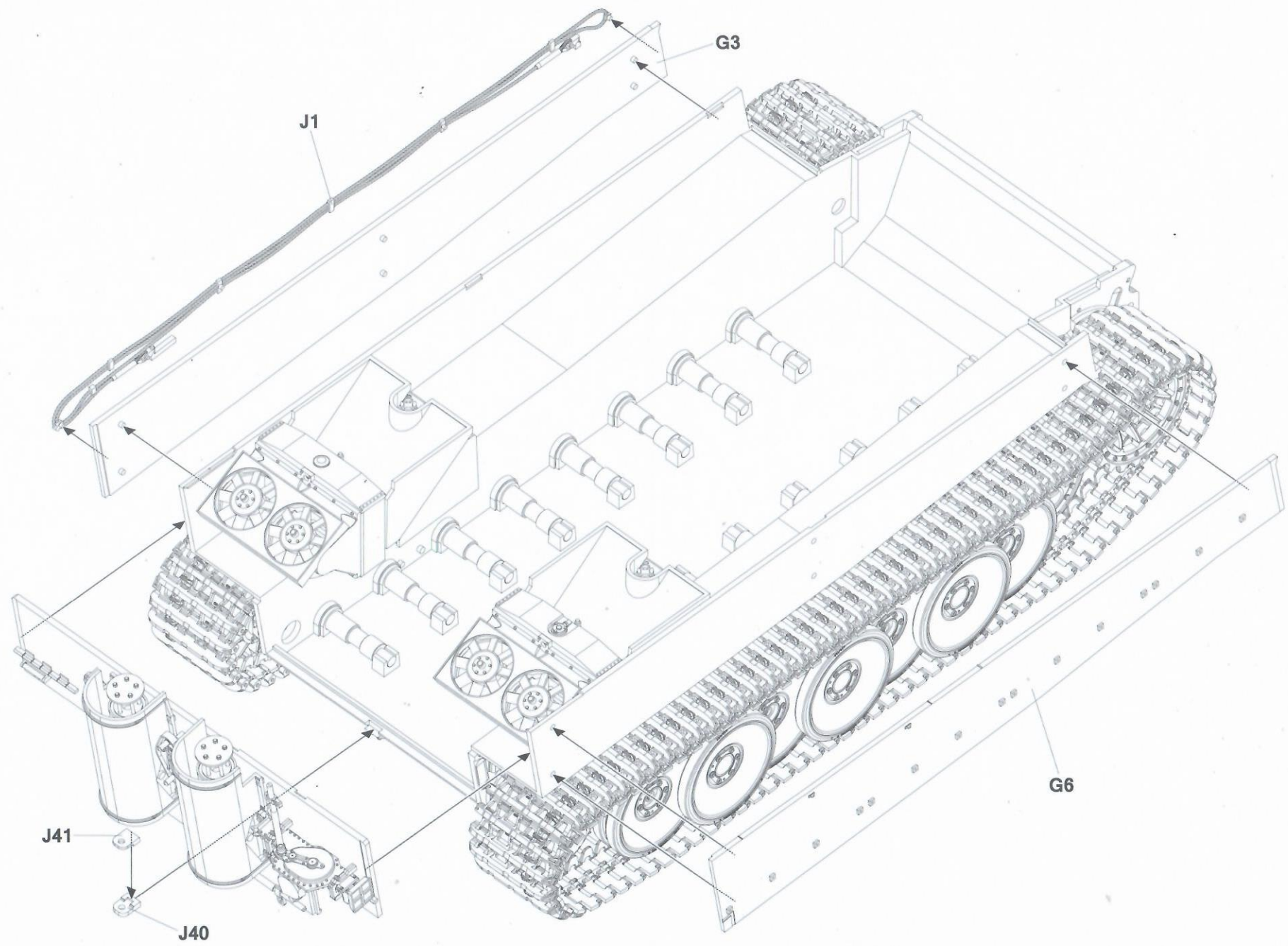

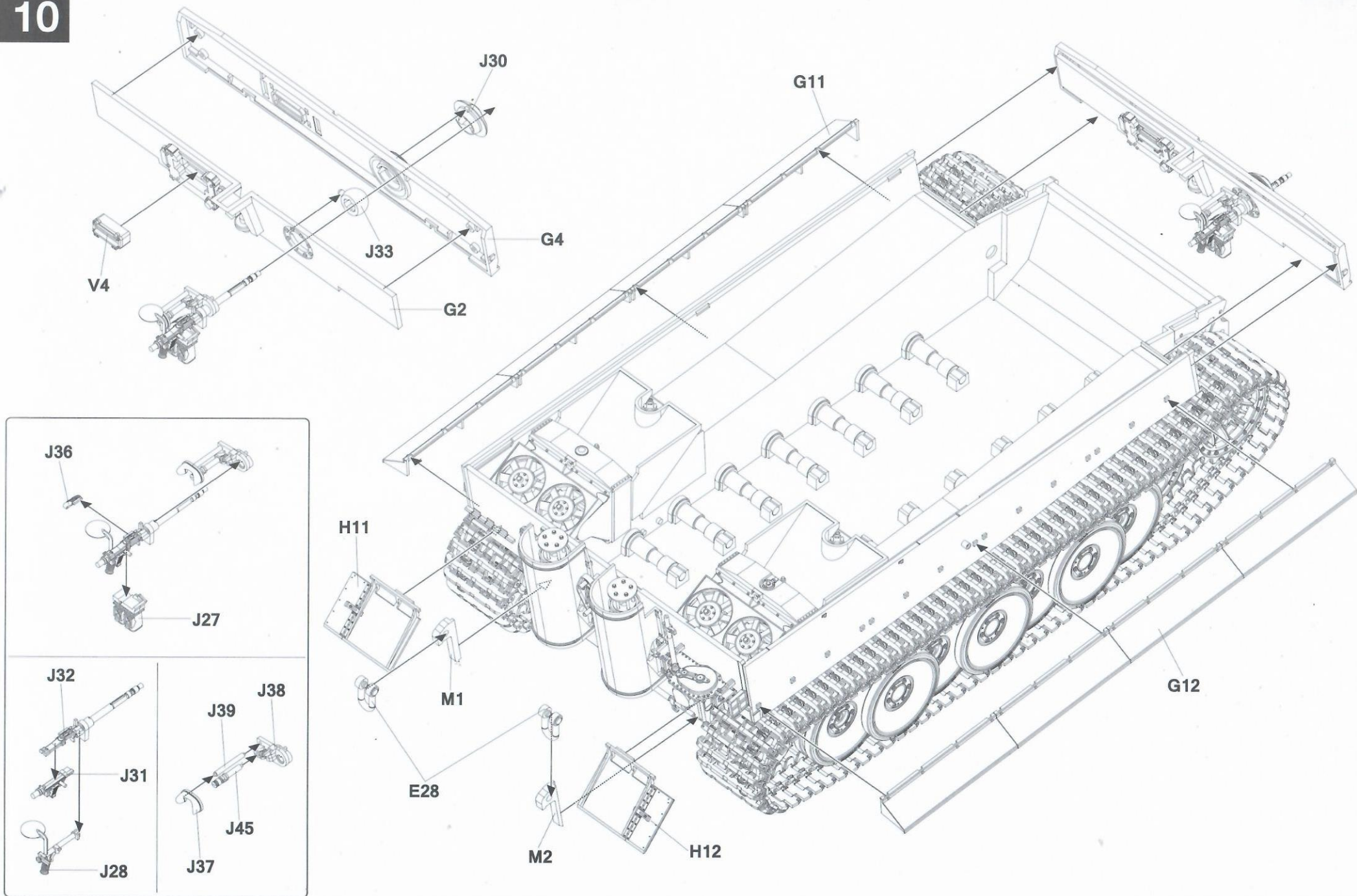

11

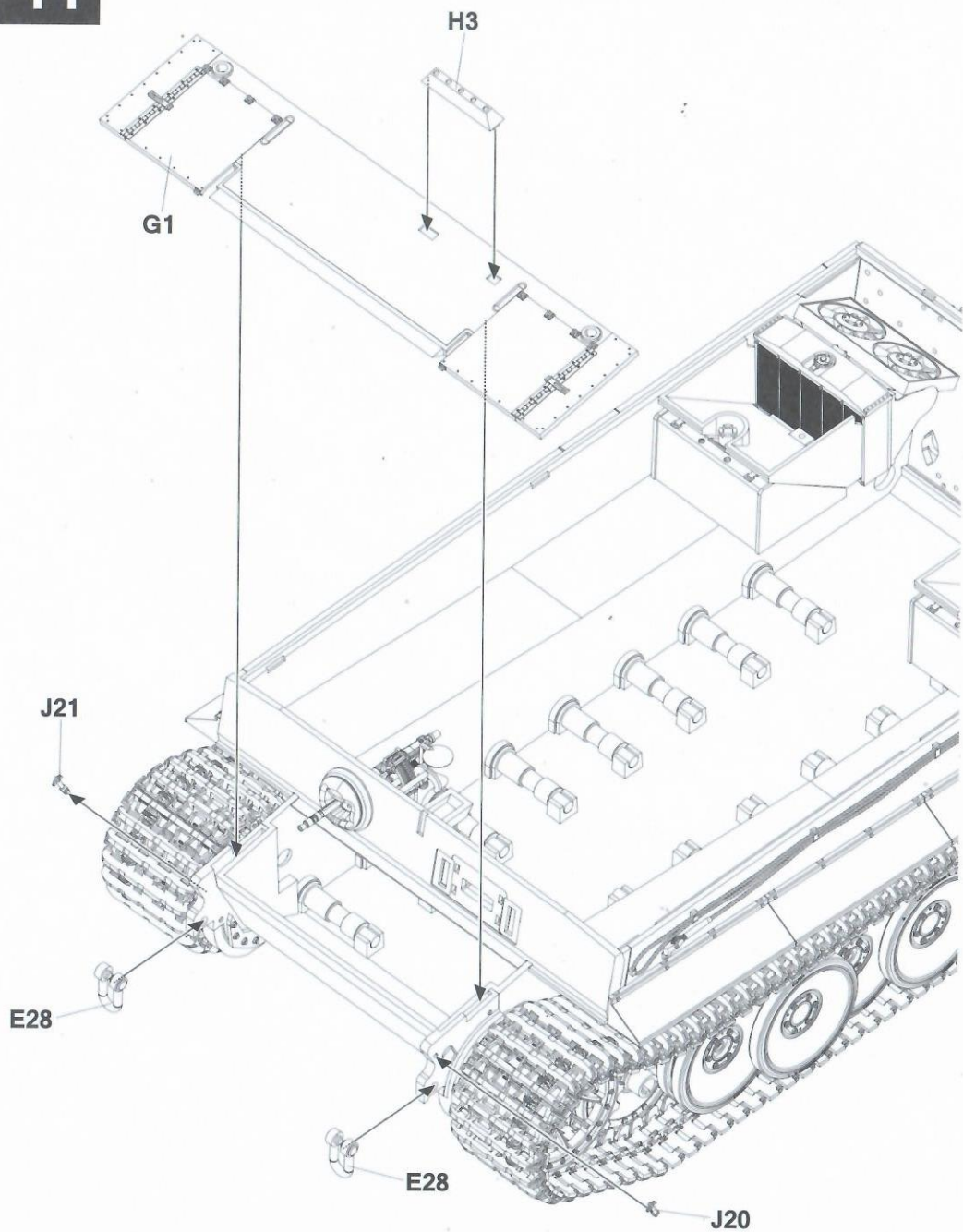

12

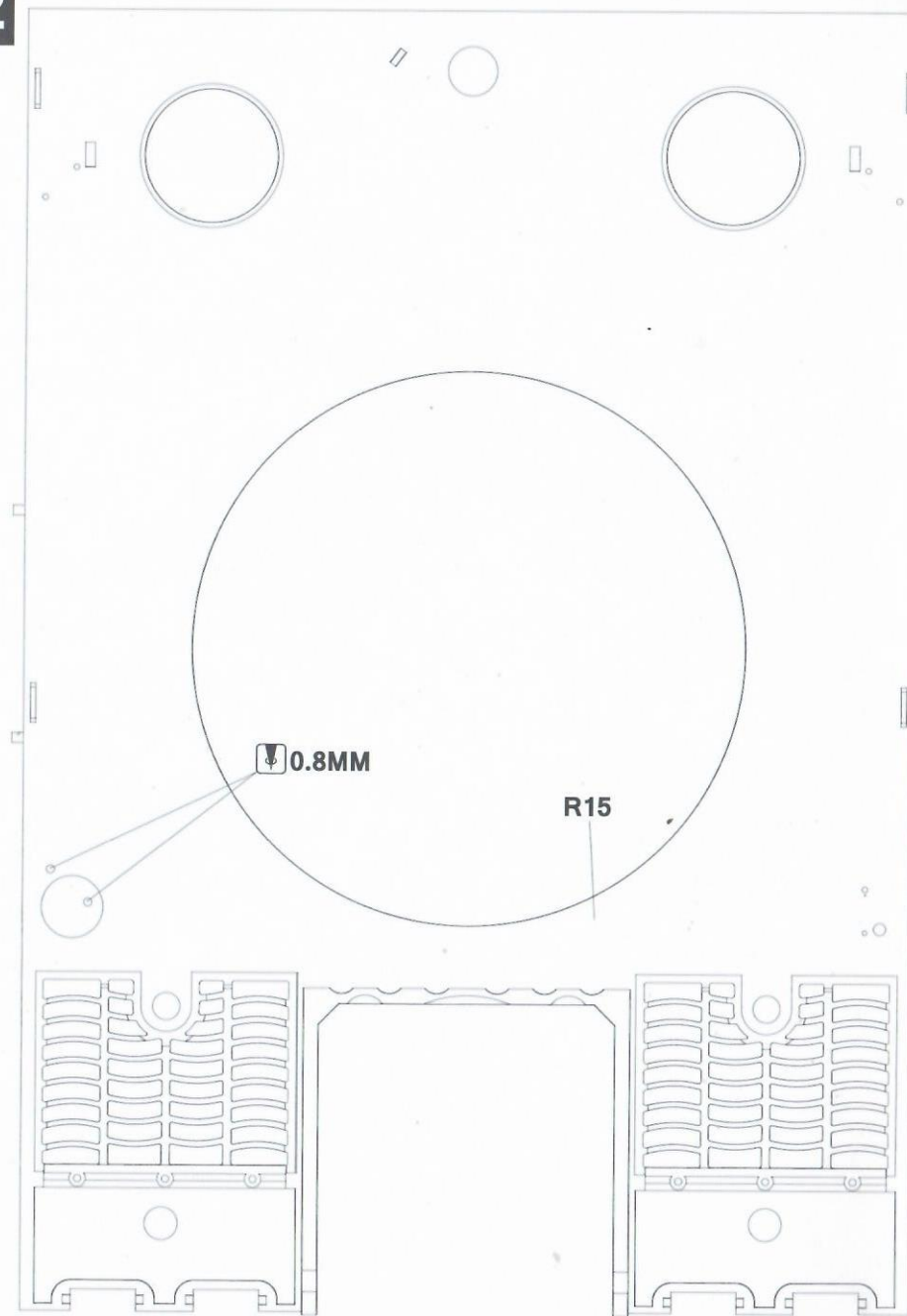

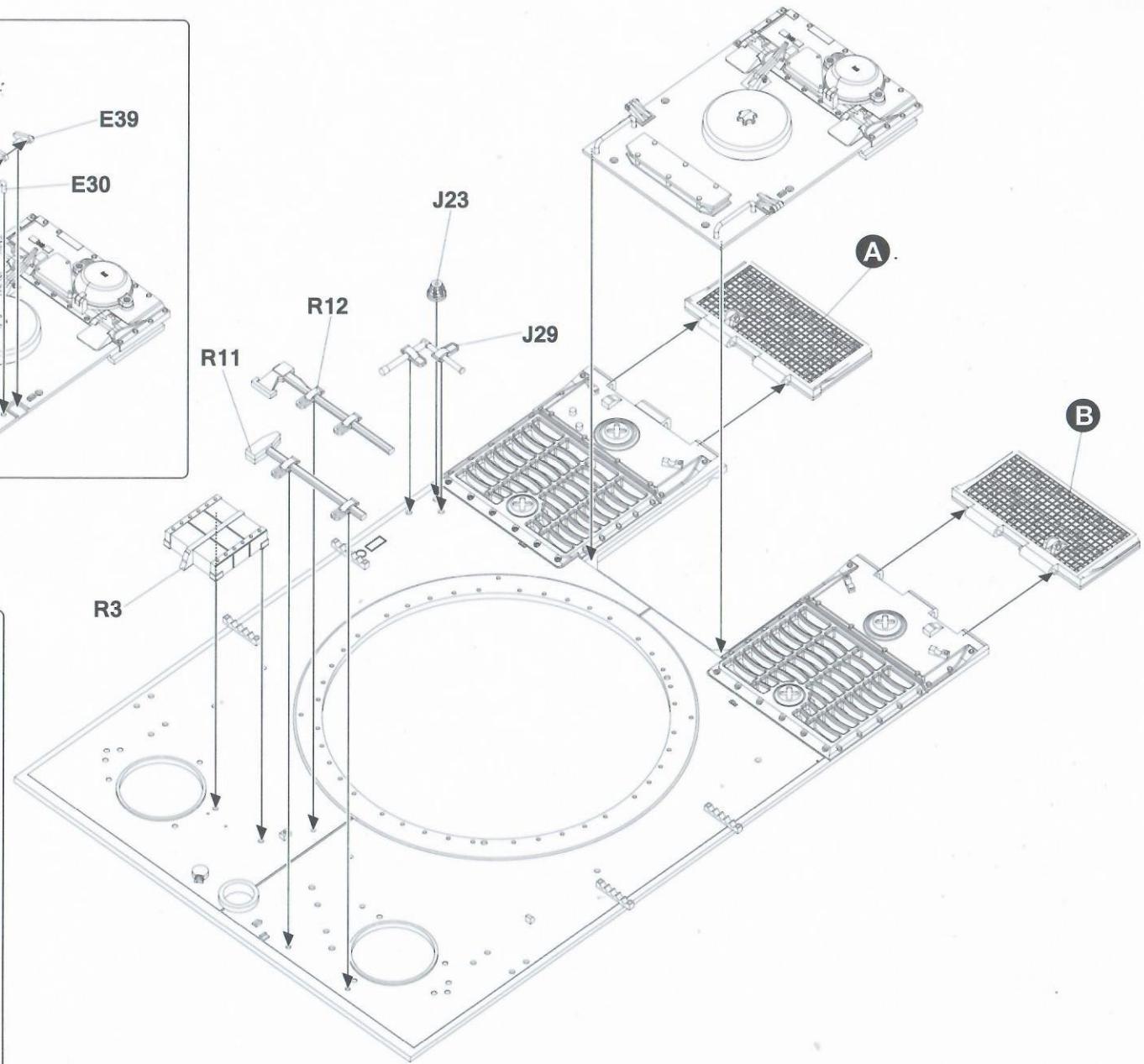
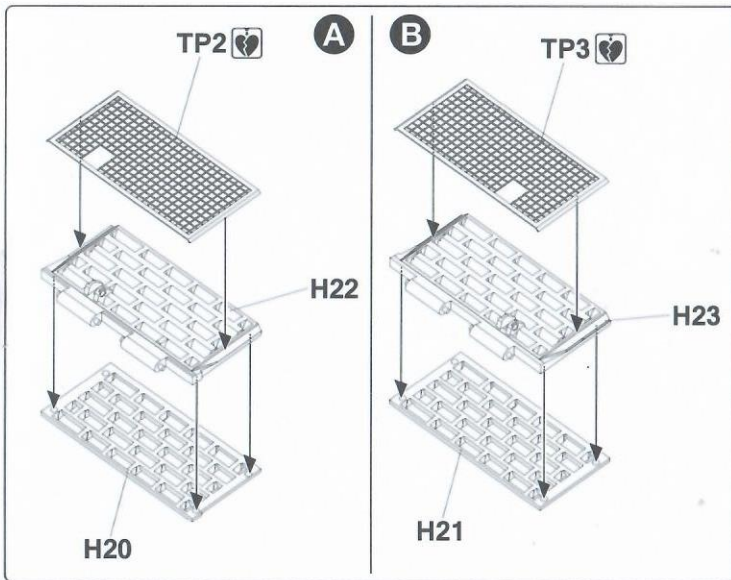
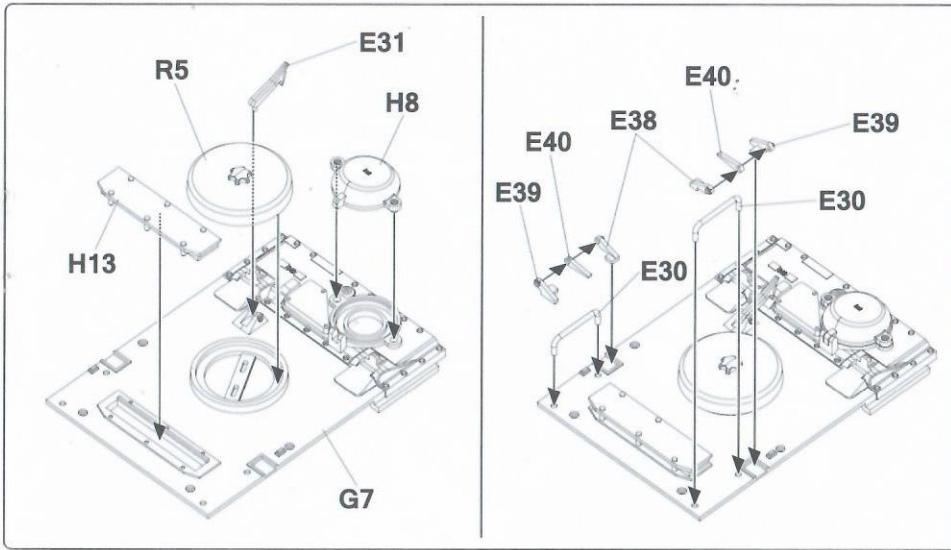

14

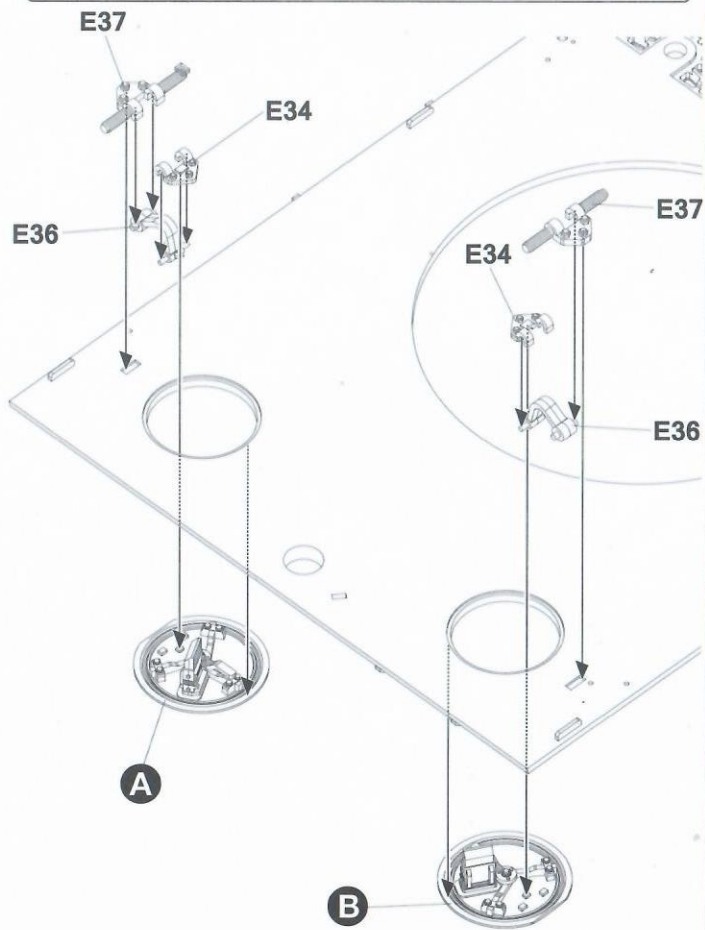
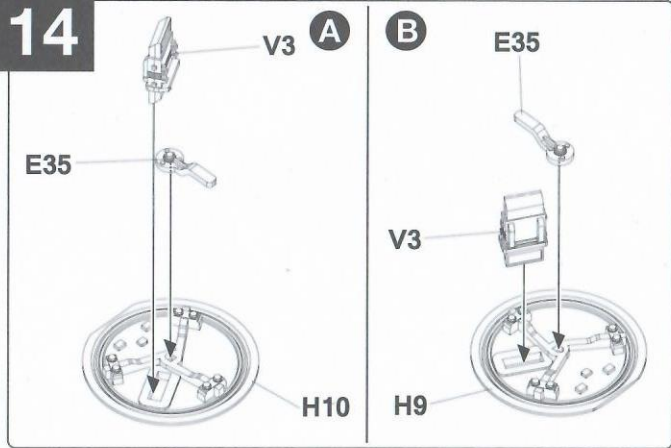

15

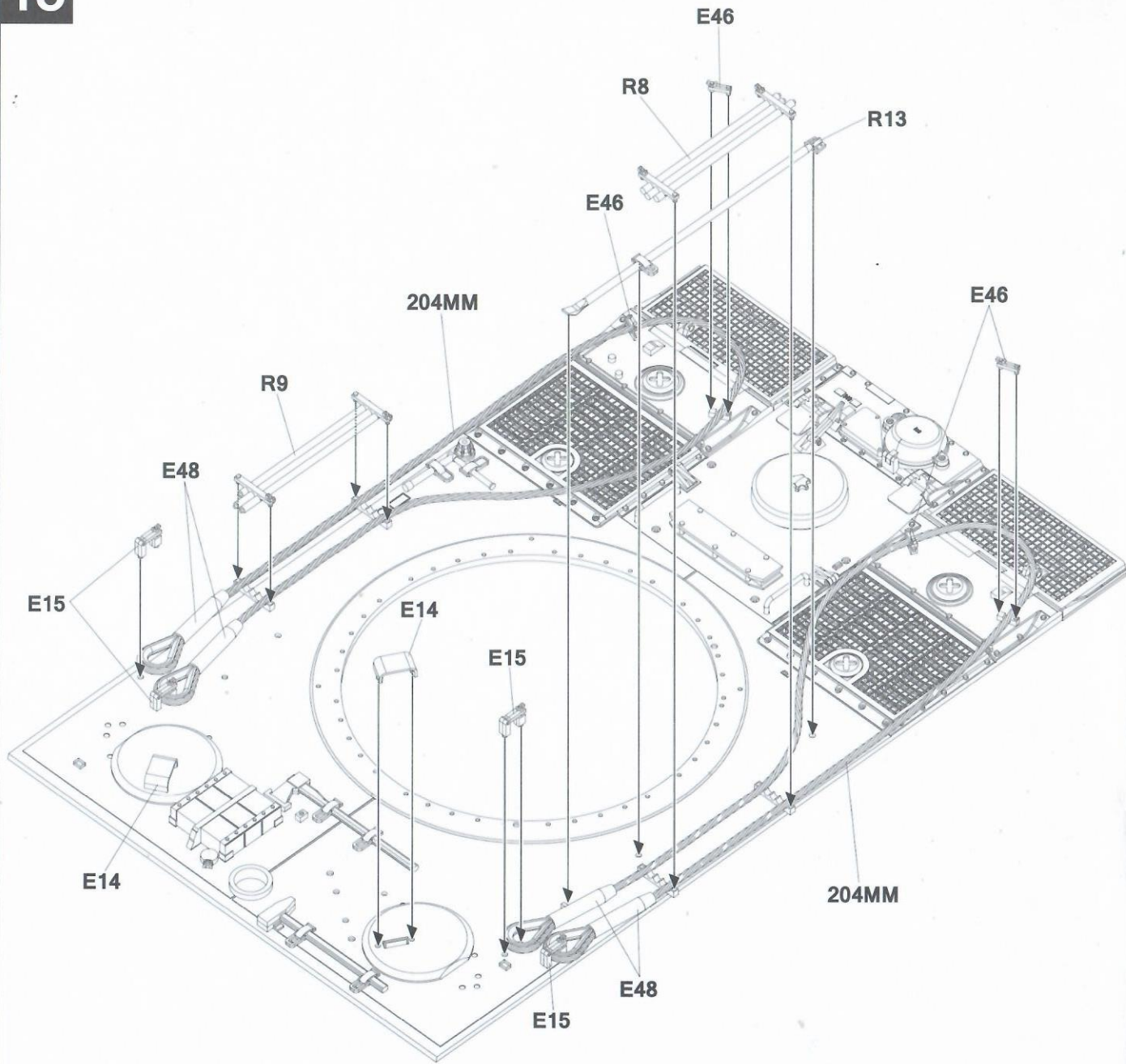

16

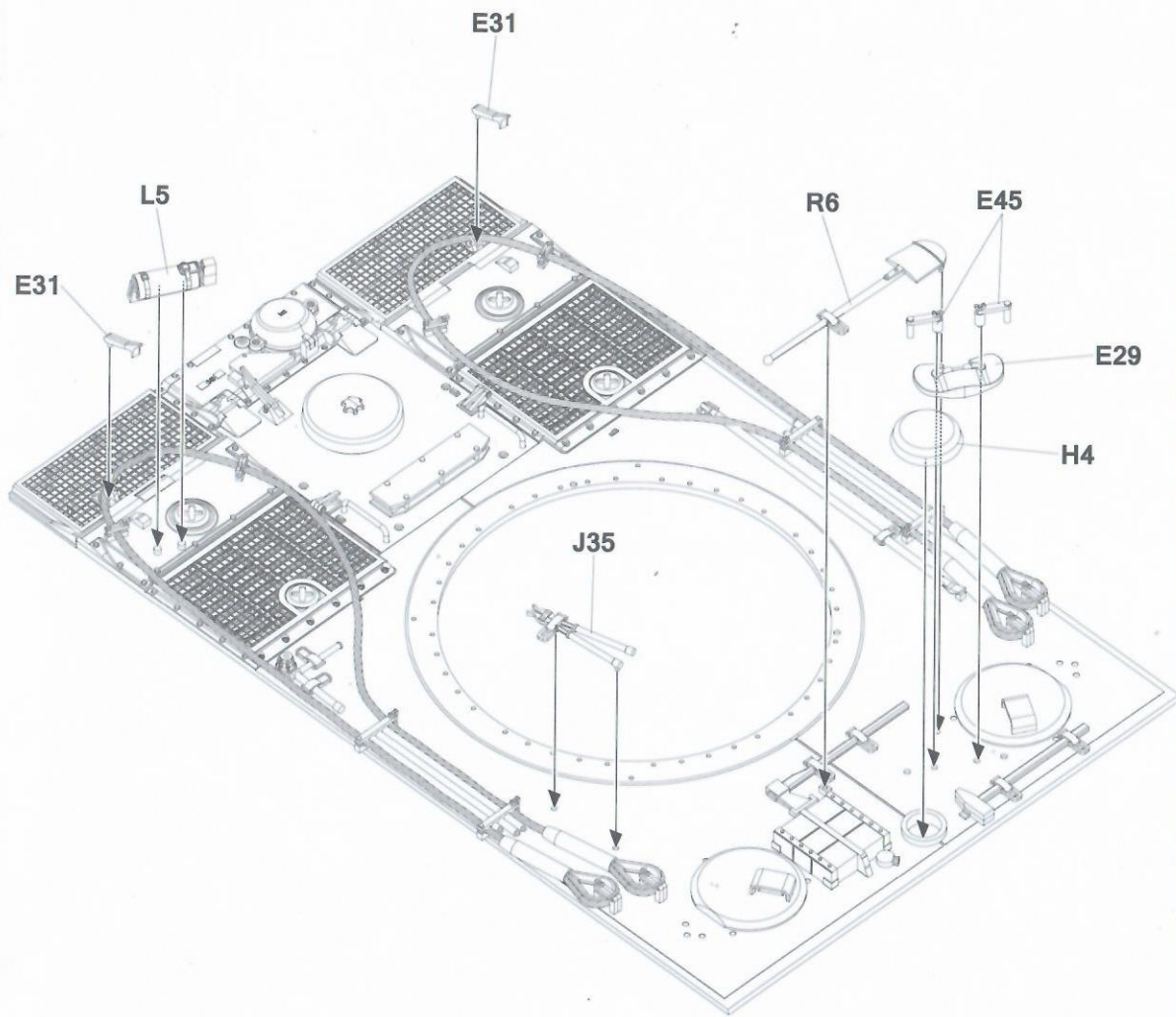

17

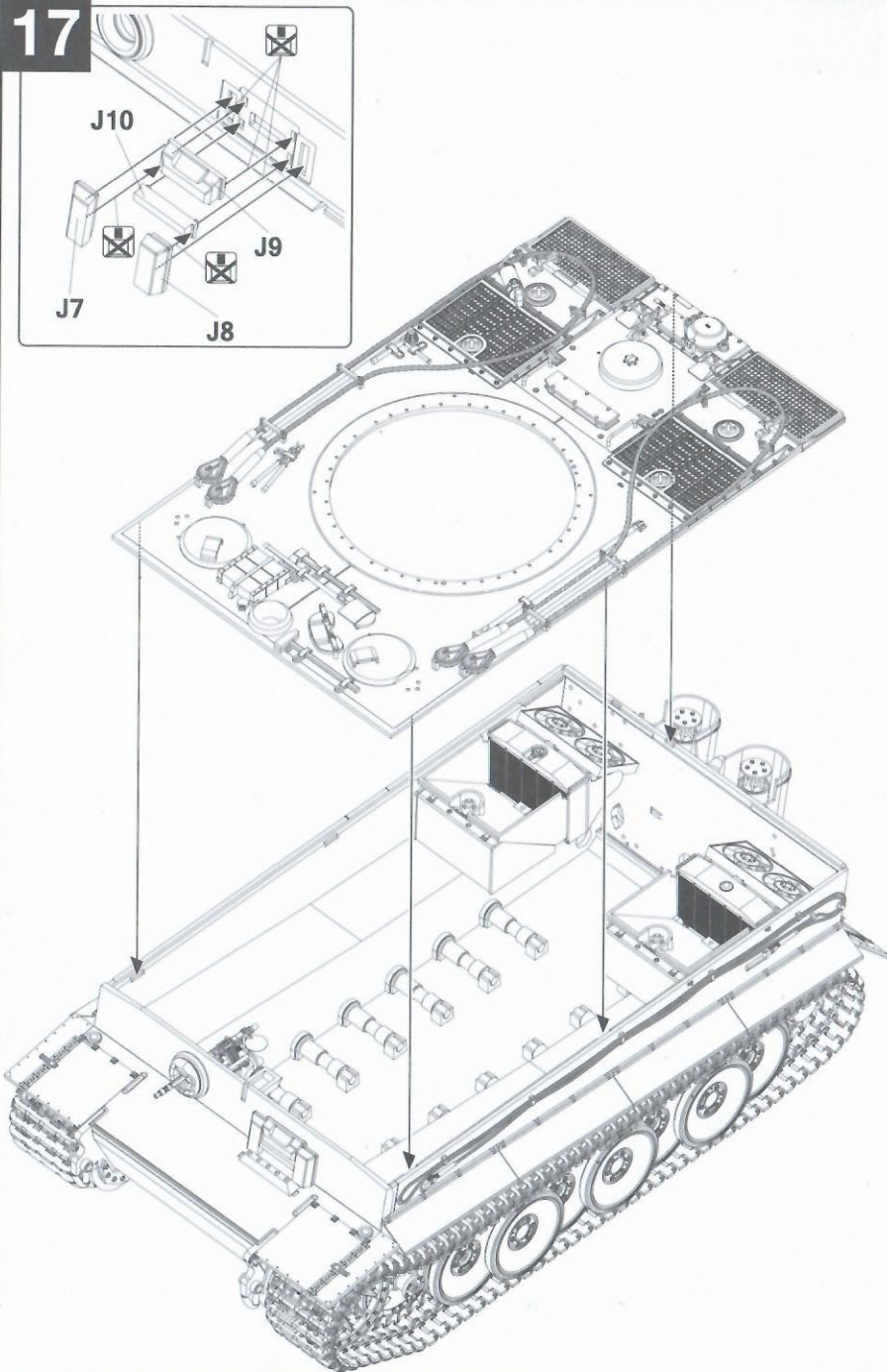

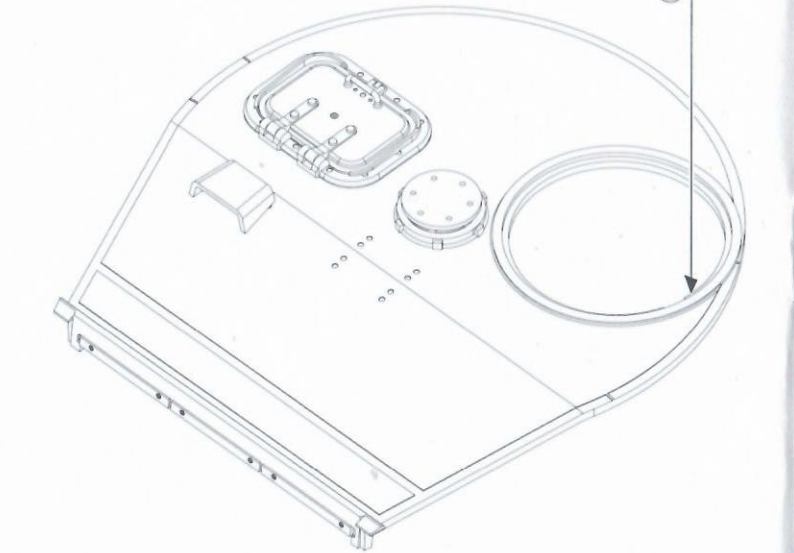
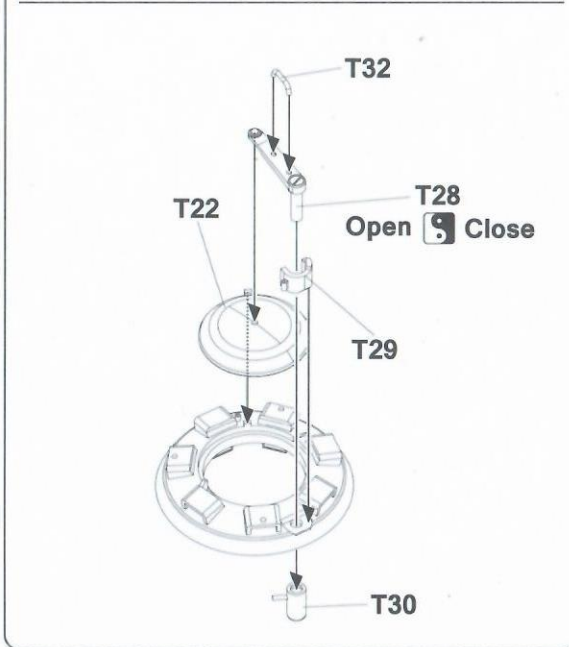
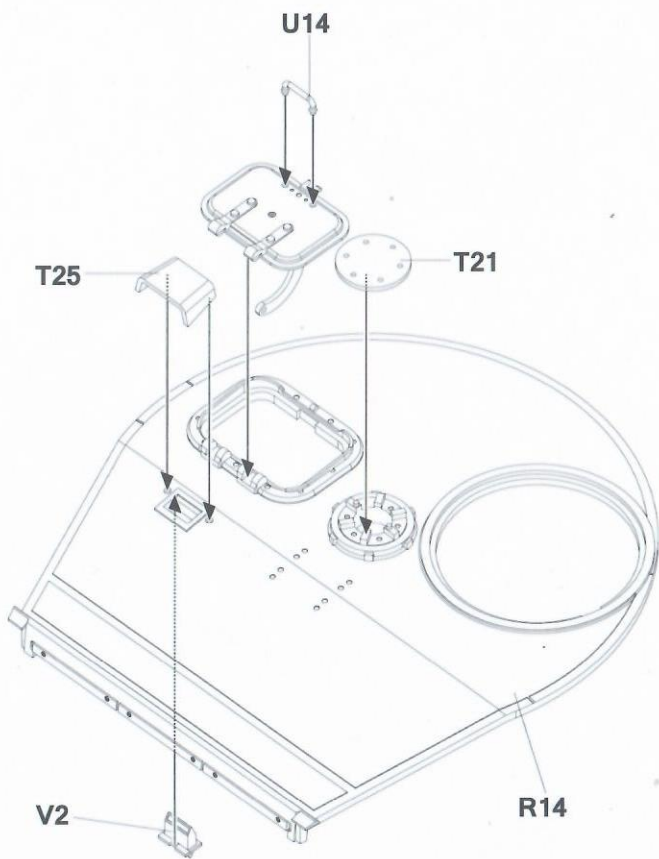
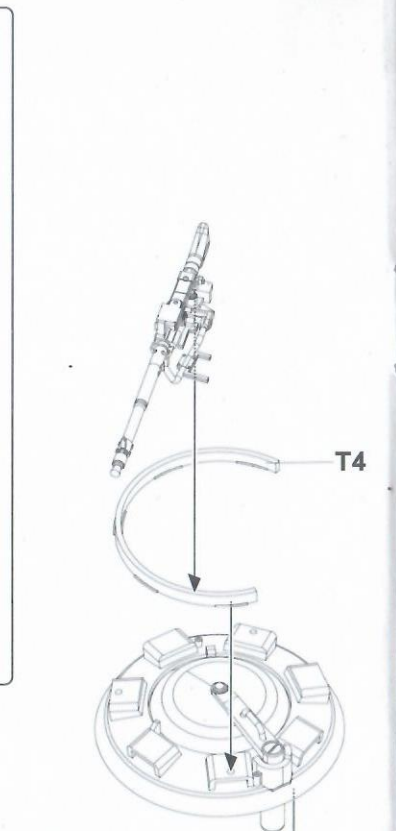
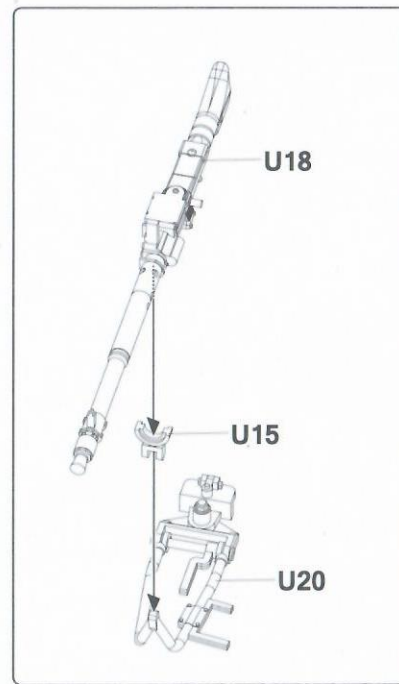
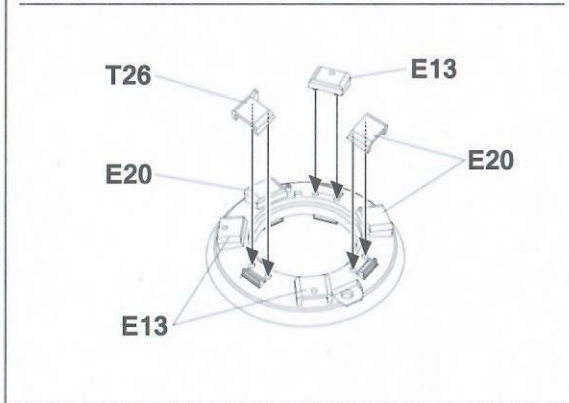
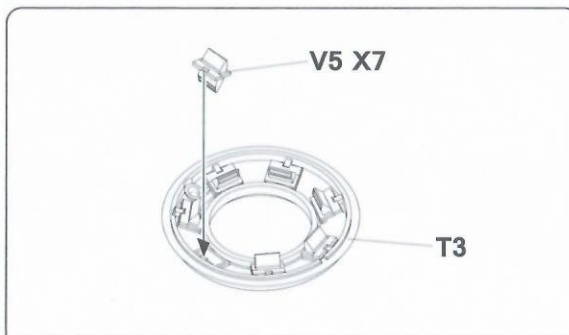
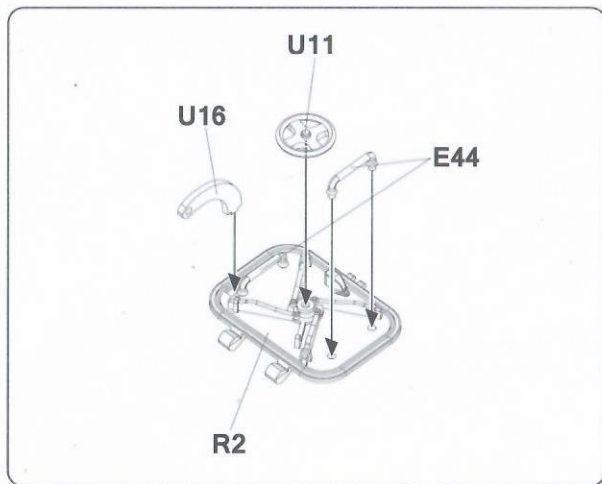

19

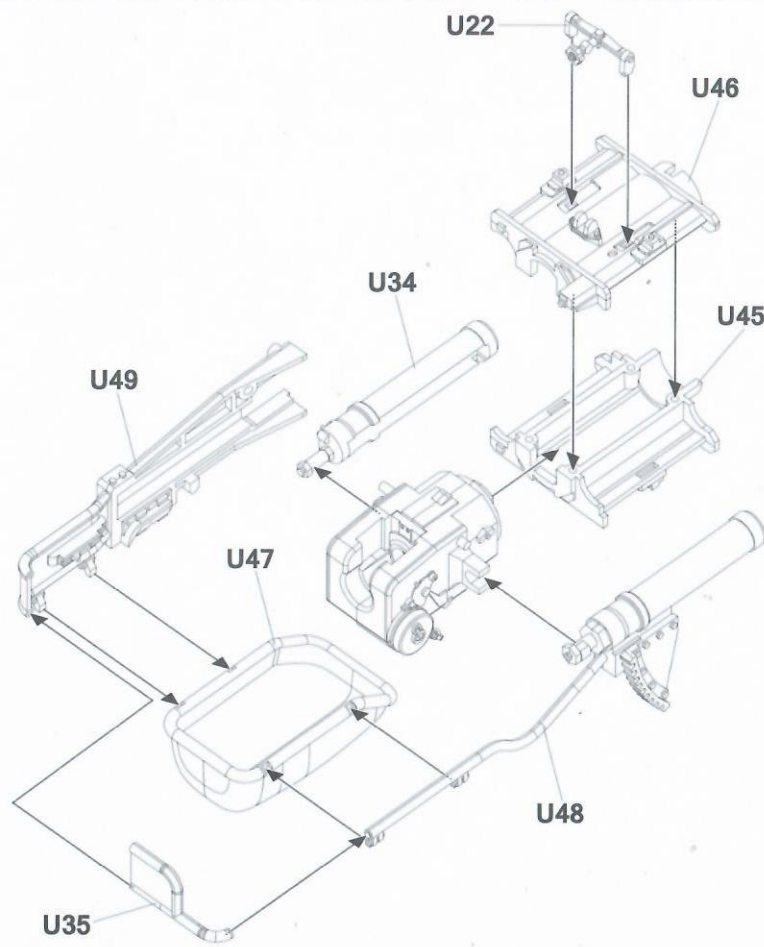
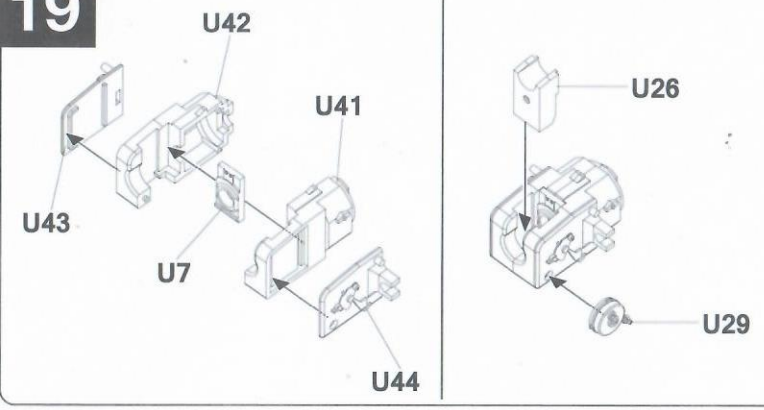

20

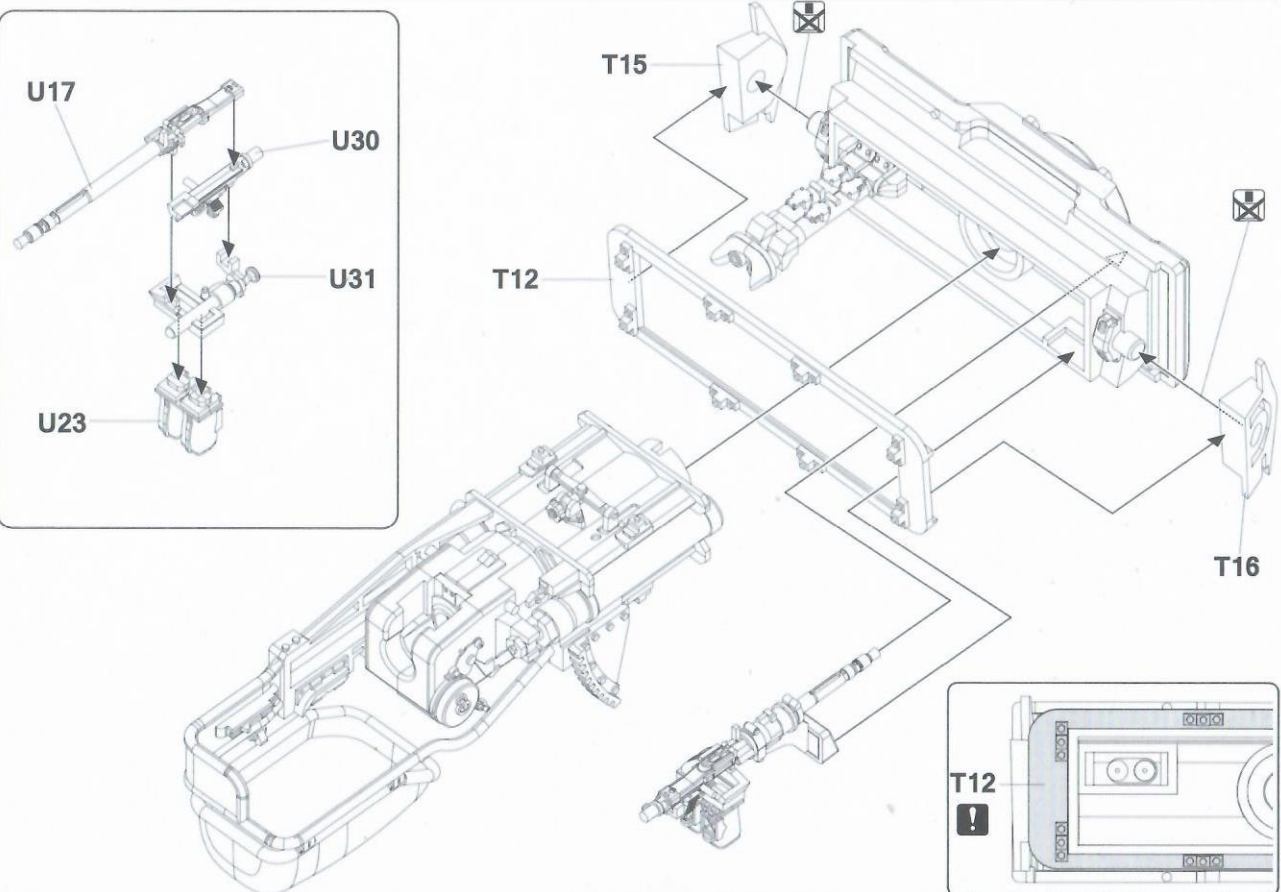
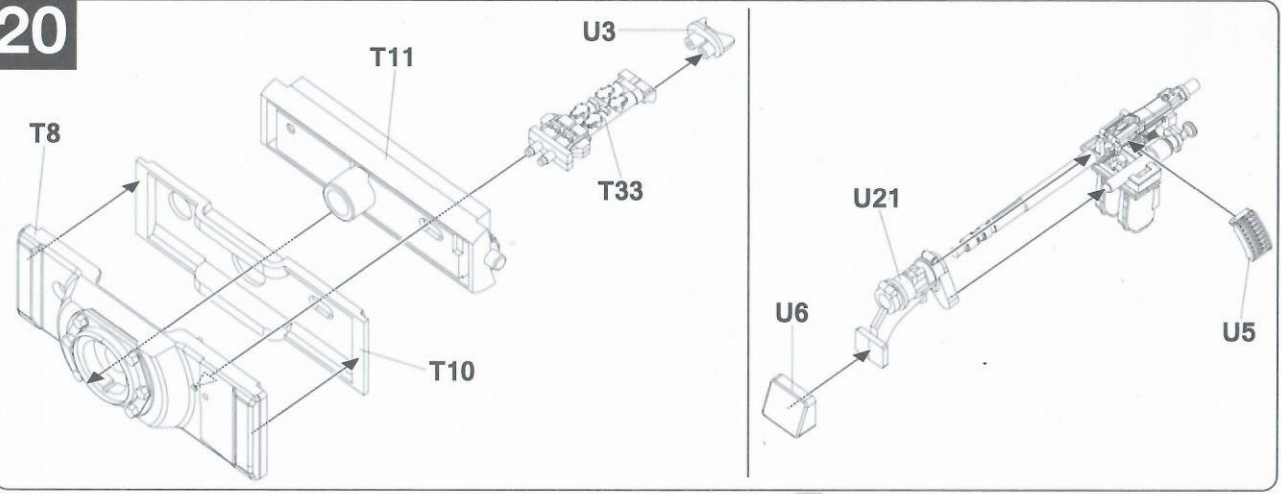

16

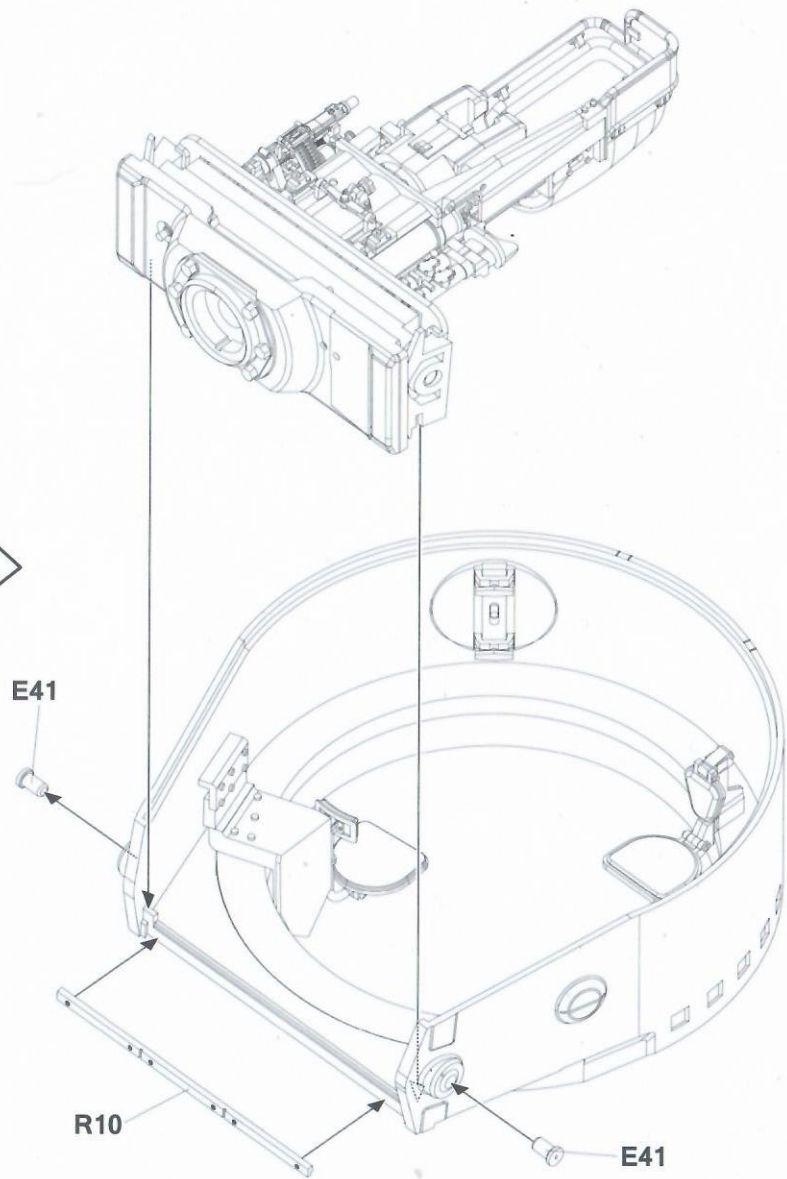
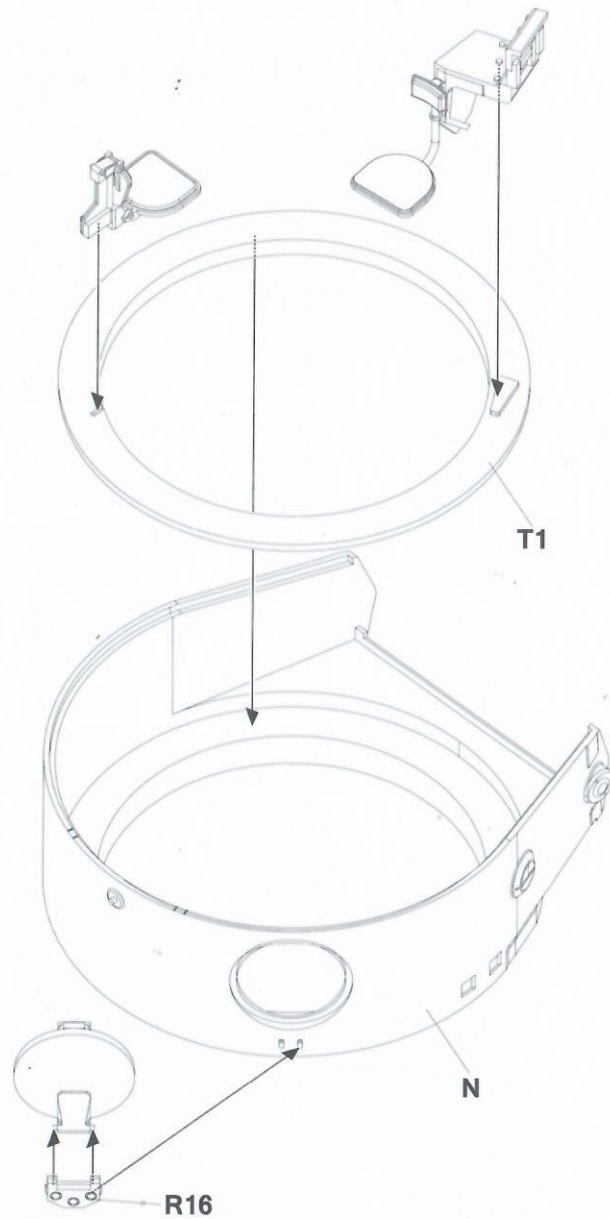
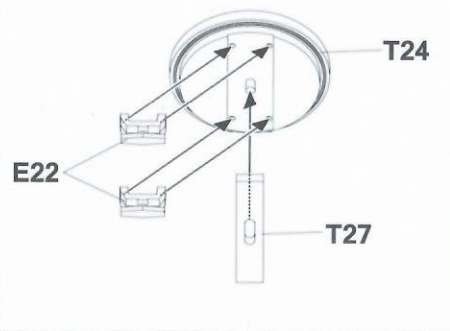
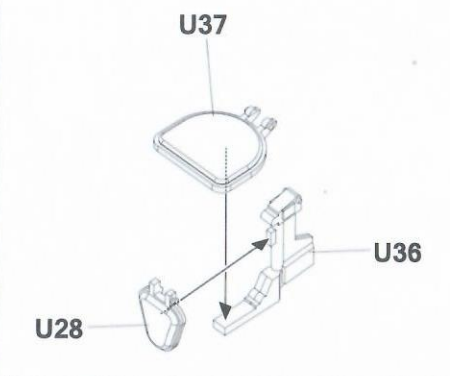
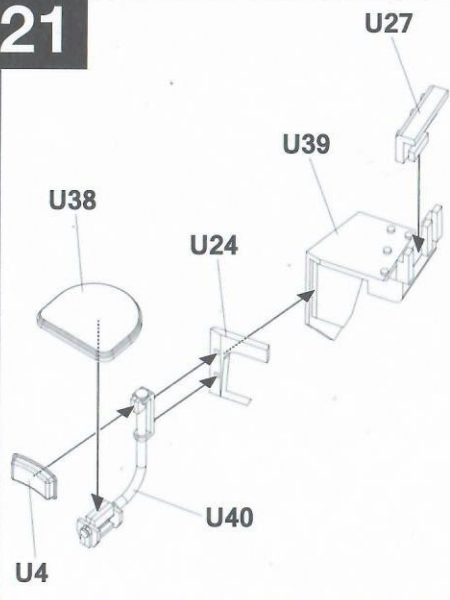

22

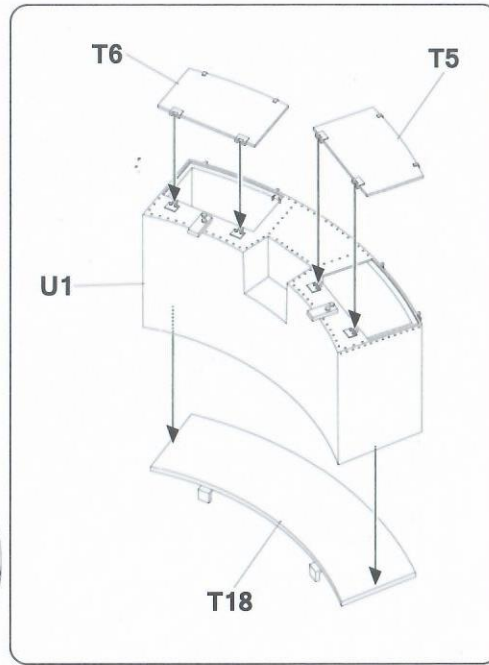
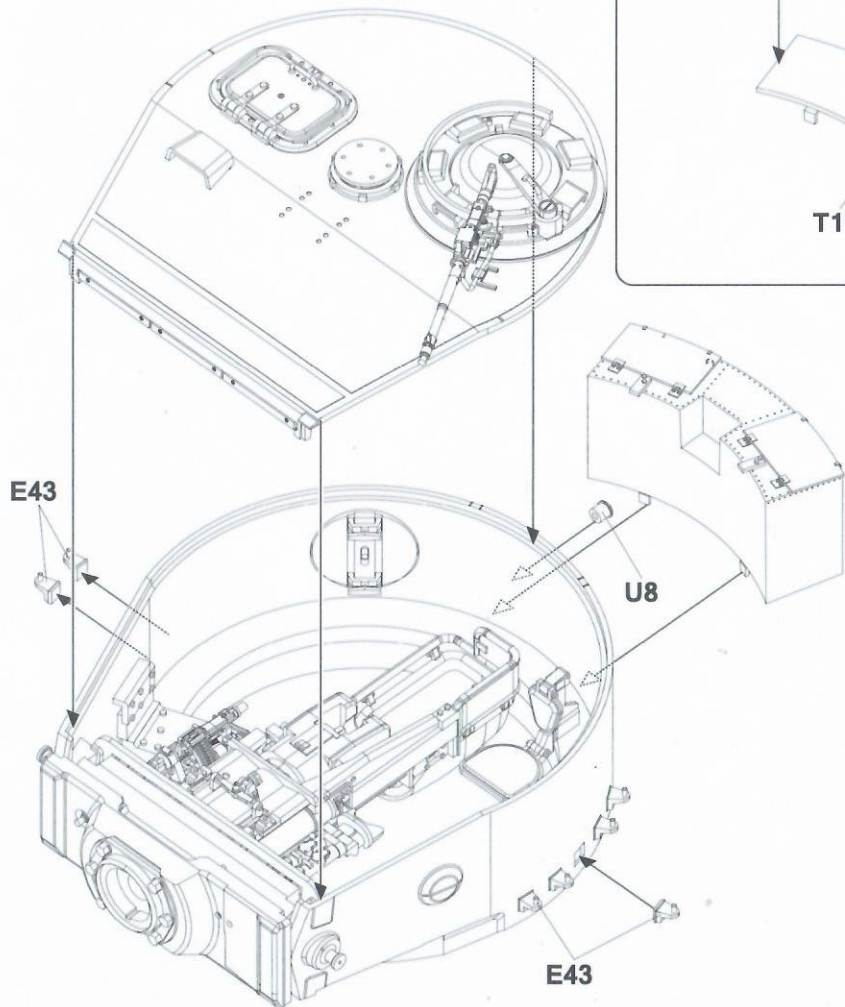

23

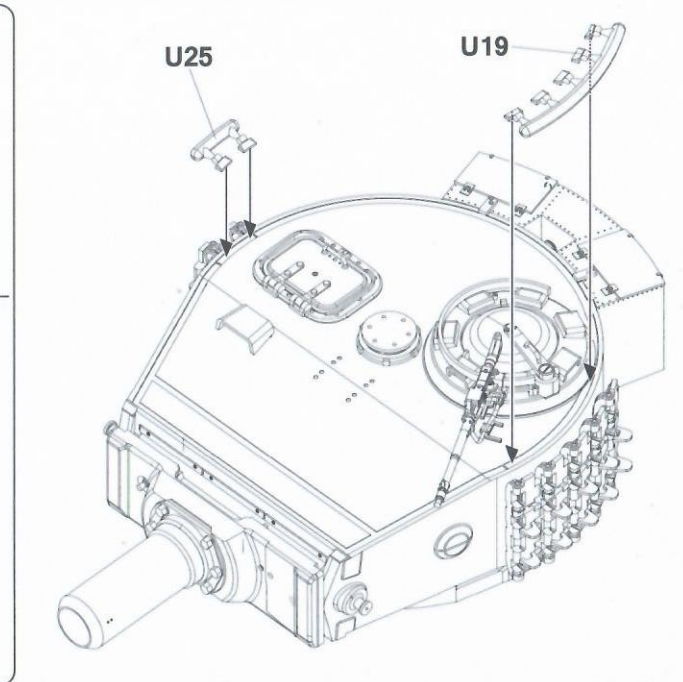
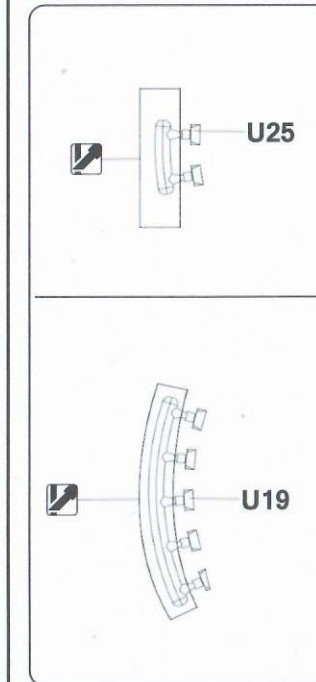
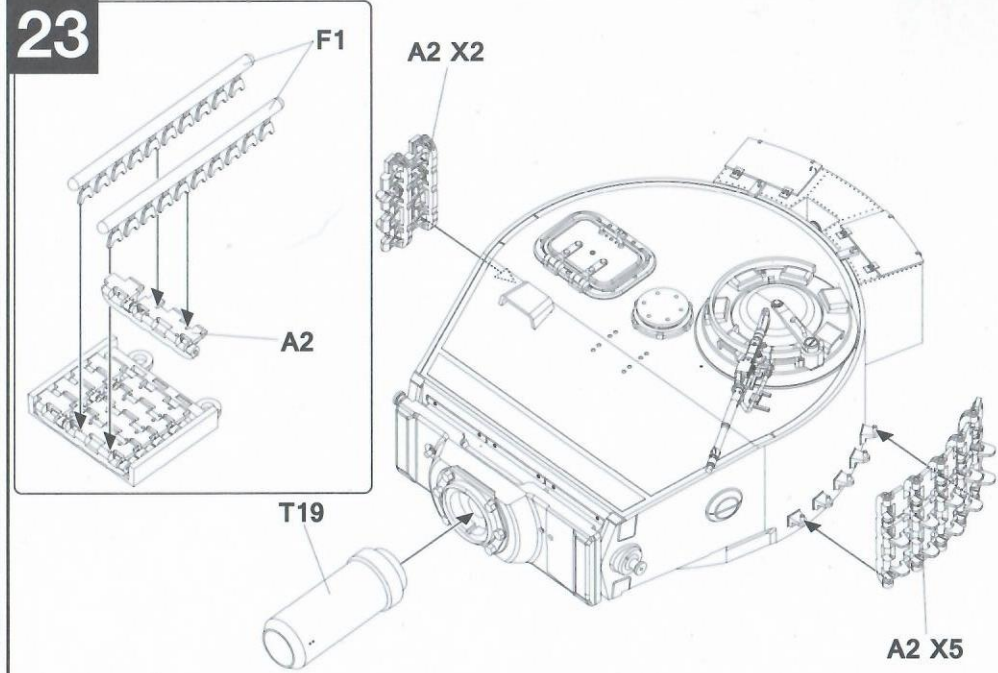

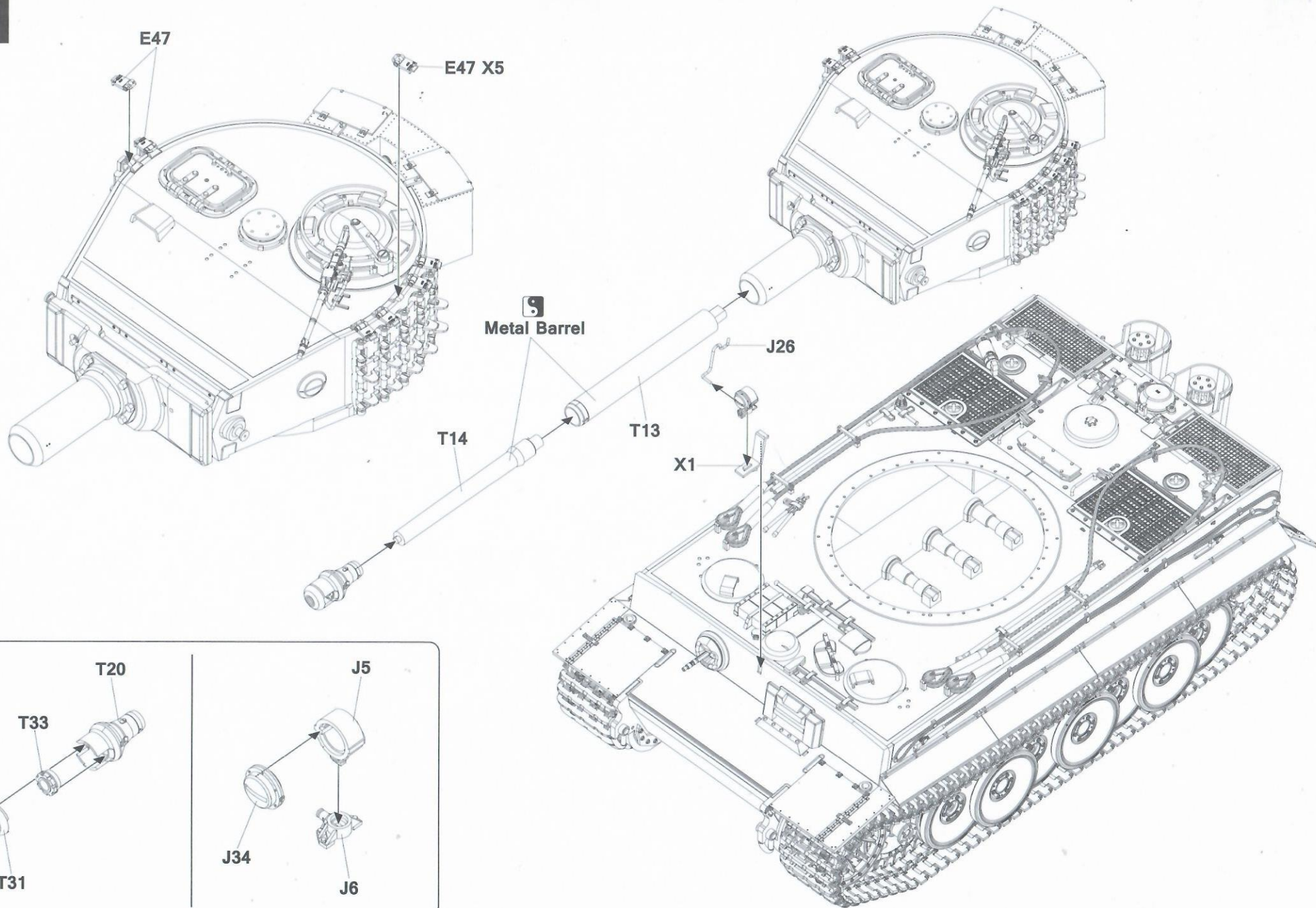

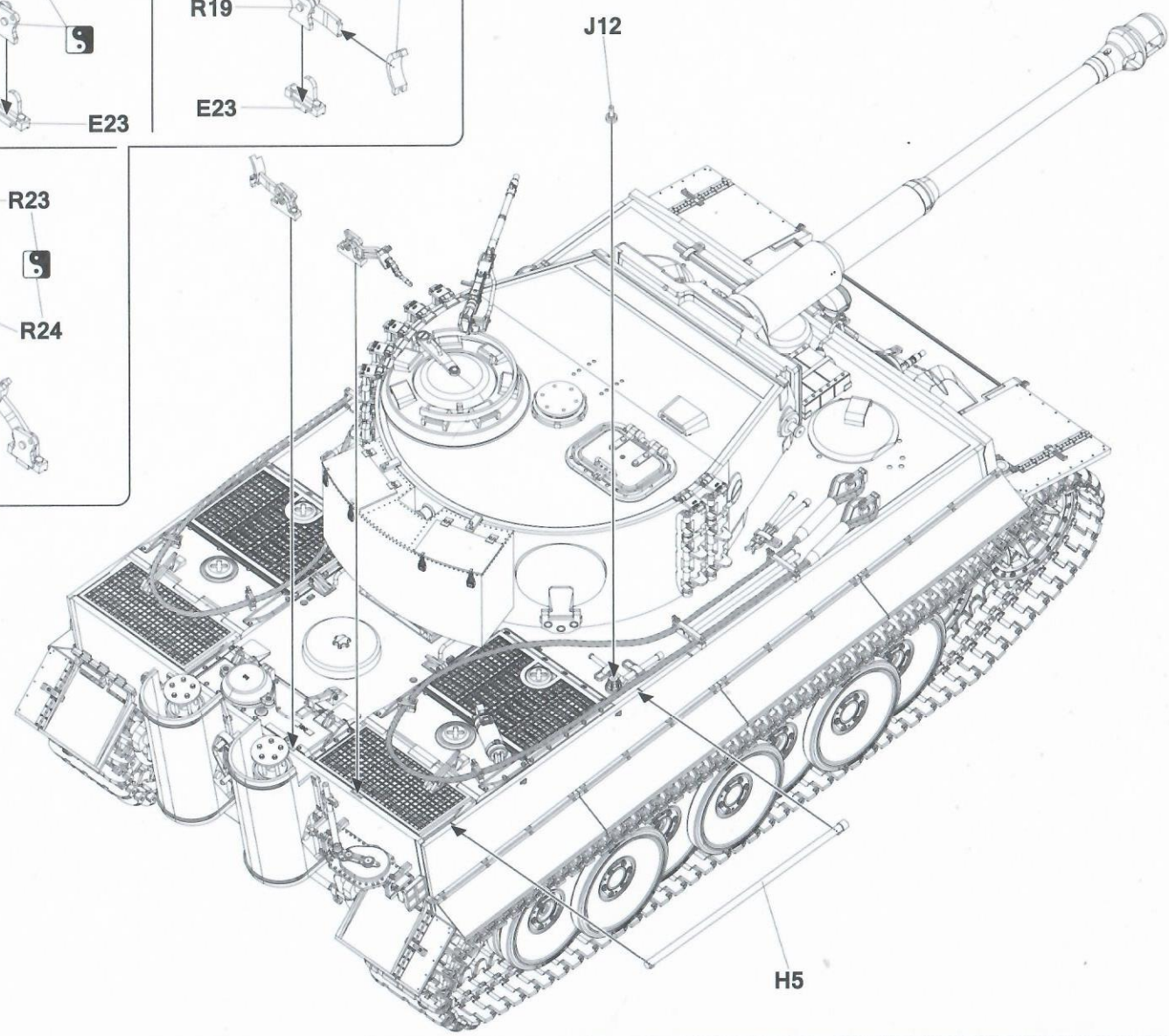
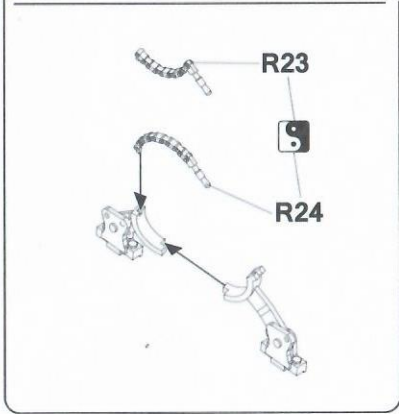
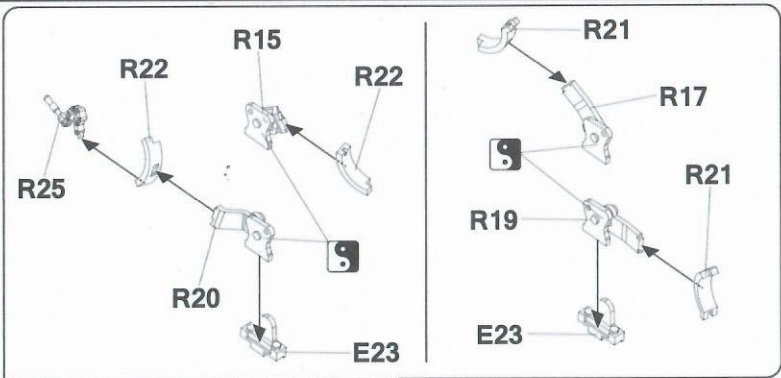
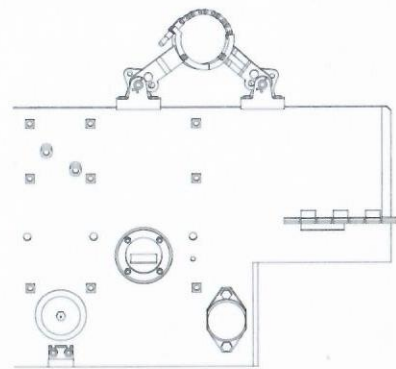
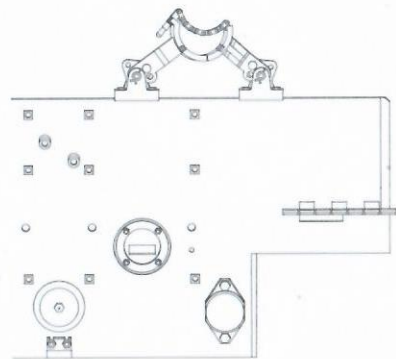
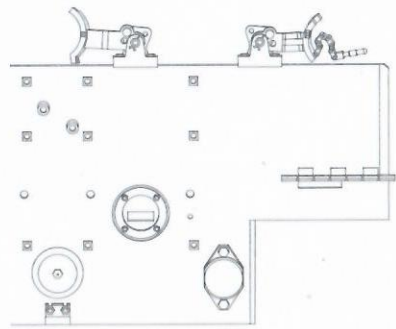

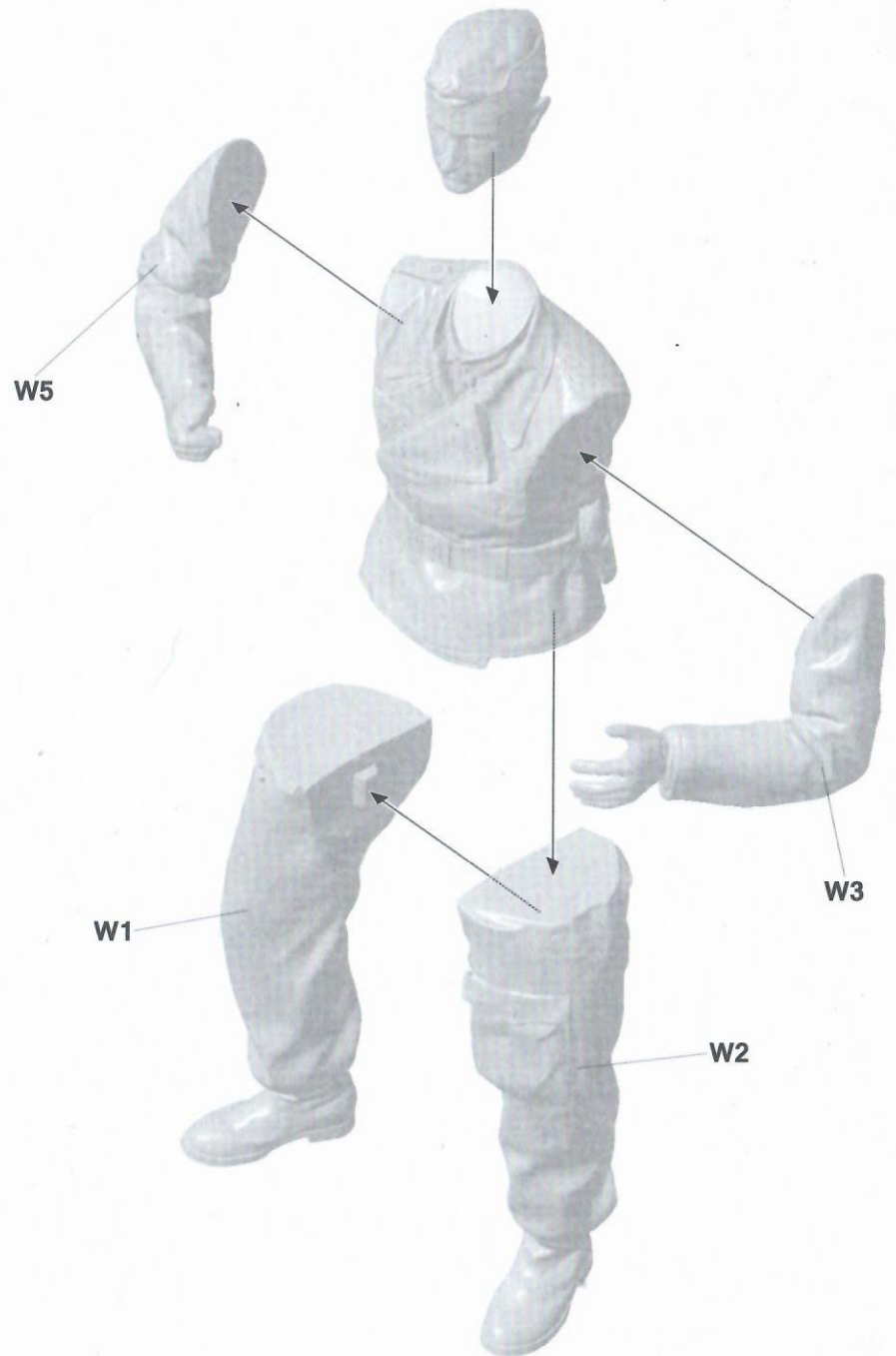
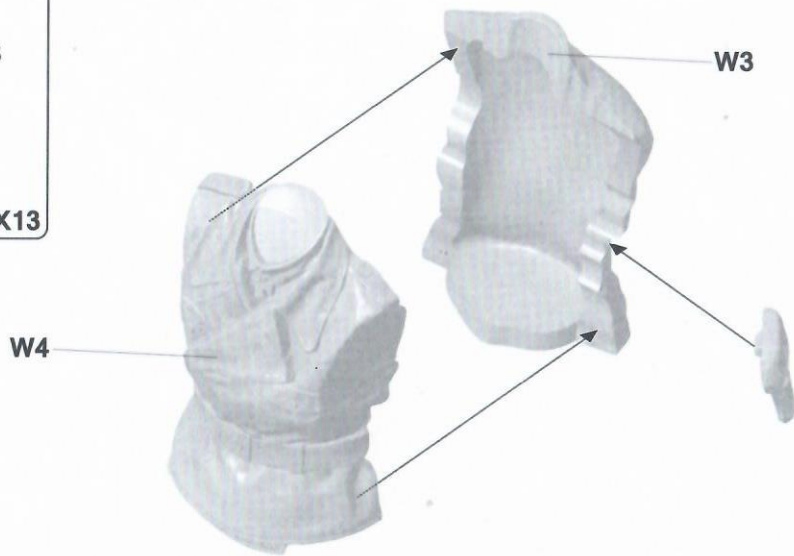
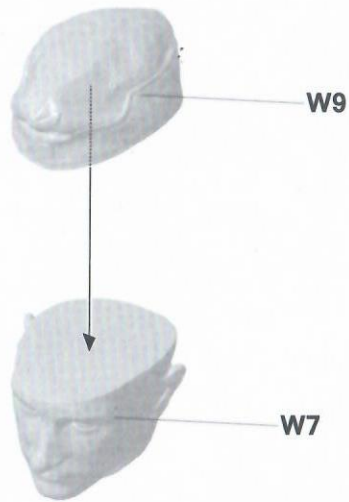
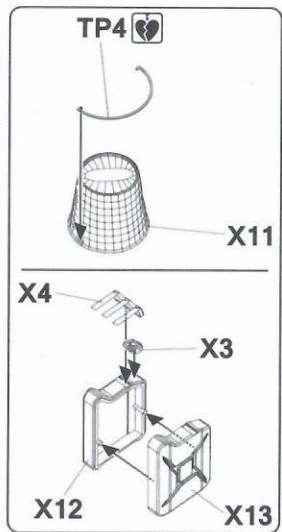
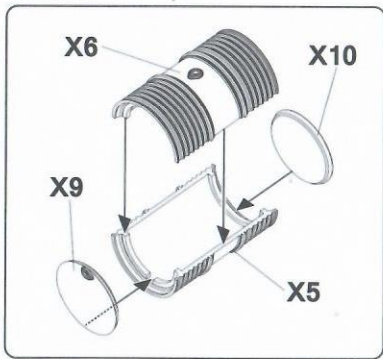

TIGER I MID-PRODUCTION w/Zimmerit

Painting and Marking Guide

TAKOM N°: 2200

2./schwere Panzerabteilung 502, Eastern
Front, July 1944

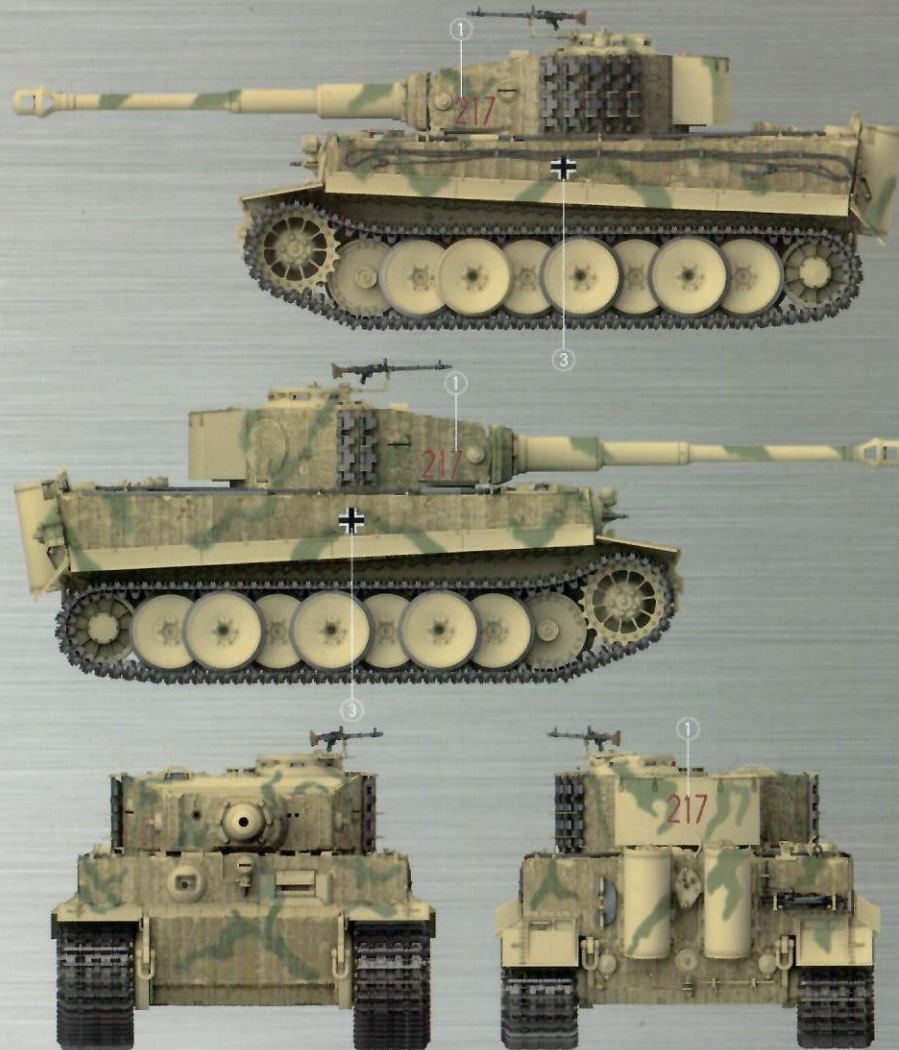

TIGER I MID-PRODUCTION w/Zimmerit

Painting and Marking Guide

TAKOM N°: 2200

2./schwere Panzerabteilung 502, Eastern
Front, July 1944

