

THE B-17 FLYING FORTRESS IS ONE OF THE BEST KNOWN U.S. AIR FORCE BOMBERS USED DURING WORLD WAR II. IT WAS CALLED THE FLYING FORTRESS BECAUSE ITS SOUND DESIGN AND HEAVY ARMAMENT ENABLED IT TO BE DEFENDED FROM ANY ANGLE. FIRST PUT INTO SERVICE IN JULY OF 1935, THE B-17 HAS BEEN SERVING VARIOUS ROLES FOR 50 YEARS.

KNOCK-OUT DROPPER IS AN EXAMPLE OF THE DURABILITY OF THE FLYING FORTRESS. A B-17F, IT WAS THE FIRST OF ITS TYPE IN THE AMERICAN EIGHTH

AIR FORCE, IN ENGLAND, TO COMPLETE 50 MISSIONS, REACHING THIS MILESTONE ON NOVEMBER 16, 1943. FOUR MONTHS LATER, KNOCK-OUT DROPPER ALSO BECAME THE FIRST B-17 TO PERFORM 75 SUCCESSFUL MISSIONS. DURING THESE FLIGHTS SHE CARRIED 150 TONS OF BOMBS AND FLEW 675 COMBAT HOURS WITHOUT THE LOSS OF, OR EVEN INJURY TO, ANY OF HER CREW! FOLLOWING HER 75TH MISSION, KNOCK-OUT DROPPER WAS RETIRED TO THE UNITED STATES.

ENGLISH: ASSEMBLY DRAWINGS SHOULD BE REVIEWED BEFORE PROCEEDING WITH CONSTRUCTION. A NUMBER IDENTIFIES EACH PLASTIC PART FOR YOUR CONVENIENCE. PAINT SMALL PARTS ON RUNNER BEFORE REMOVING. ALLOW PAINT TO DRY THOROUGHLY BEFORE CONTINUING ASSEMBLY OF KIT. SCRAPE CHROME OR PAINT AT AREA TO BE GLUED. WASH PLASTIC IN MILD DETERGENT SOLUTION. RINSE AND LET DRY FOR BETTER PAINT AND DECAL ADHESION.

FRANÇAIS: ÉTUDIEZ LES SCHEMAS DE MONTAGE AVANT DE COMMENCER LA CONSTRUCTION. UN NUMERO IDENTIFIE CHAQUE PIECE EN PLASTIQUE POUR PLUS DE FACILITE. PEIGNEZ LES PETITES PIECES SUR LE COURSEUR AVANT DE LES ENLEVER. LAISSEZ SECHER LA PEINTURE AVANT DE CONTINUER LE MONTAGE DU KIT. GRATTEZ LE CHROME OU LA PEINTURE DANS LES ZONES QUI DOI

VENT ETRE COLLEES. PUIS LAVEZ LE PLASTIQUE DANS UNE SOLUTION FAIBLE DE DETERGENT RINCEZ ET LAISSEZ SECHER A L'AIR POUR ASSURER UNE MEILLEURE ADHERENCE DE LA PEINTURE ET DES DECALOMANIES.

ESPAÑOL: ESTUDIE LOS PLANOS DE MONTAJE ANTES DE INICIAR LA CONSTRUCCION. PARA FACILITAR LAS COSAS, CADA PIEZA DE PLASTICO LLEVA UN NUMERO DE IDENTIFICACION. PINTE LAS PIECITAS DEL CORREDOR ANTES DE QUITARLAS. PERMITA QUE LA PINTURA SE SEQUE BIEN ANTES DE PROSEGUIR EL MONTAJE DEL EQUIPO. RASPE EL CROMO O LA PINTURA DE LAS ZONAS QUE SE VAYAN A ENCOLAR. LAVE EL PLASTICO CON UNA SOLUCION LIGERA DE DETERGENTE. ENJUAGUELO Y DEJELO SECAR AL AIRE PARA OBTENER UNA MEJOR ADHERENCIA DE LA PINTURA Y LAS CALCOMANIAS.



GLUE
COLLE
COLA



NO GLUE REQUIRED
PAS BESOIN DE COLLE
NO SE REQUIERE COLA



DO IT THIS MANY TIMES
IF FAIRE CE NOMBRE DE FOIS
HAGALO TODAS ESTAS VECES



OPTIONAL
OPTIONNEL
OPCIONAL

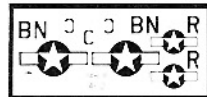

APPLY DECALS
COLLEZ LES DECALOMANIES
PEGUE LAS CALCOMANIAS



SHOWN ASSEMBLED
PRESENTE ASSEMBLE
SE PRESENTA MONTADO



CLEAR
TRANSPARENT
TRANSPARENTE



DARK OLIVE GREEN
OLIVE FONCE VERT
OLIVA OSCURO VERDE

A	CHROMATE GREEN	VERT CHROMATE	VERDE CROMATO
B	YELLOW	JAUNE	AMARILLO
C	SILVER	ARGENT	PLATA

D	MATT OLIVE GREEN	VERT OLIVE MAT	VERDE OLIVA MATE
E	MATT GREY	GRIS MAT	GRIS MATE
F	MATT BLACK	NOIR MAT	NEGRO MATE

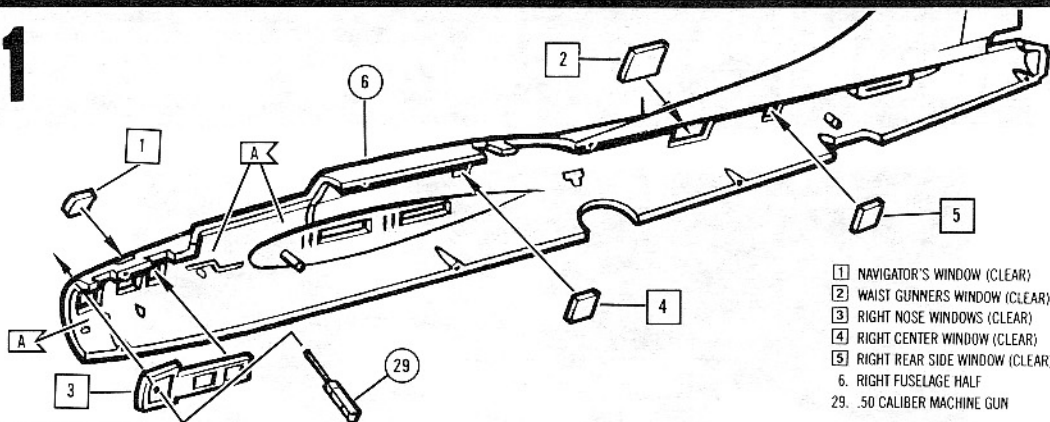
1

- 1 NAVIGATOR'S WINDOW (CLEAR)
 2 WAIST GUNNERS WINDOW (CLEAR)
 3 RIGHT NOSE WINDOWS (CLEAR)
 4 RIGHT CENTER WINDOW (CLEAR)
 5 RIGHT REAR SIDE WINDOW (CLEAR)
 6. RIGHT FUSELAGE HALF
 29. .50 CALIBER MACHINE GUN

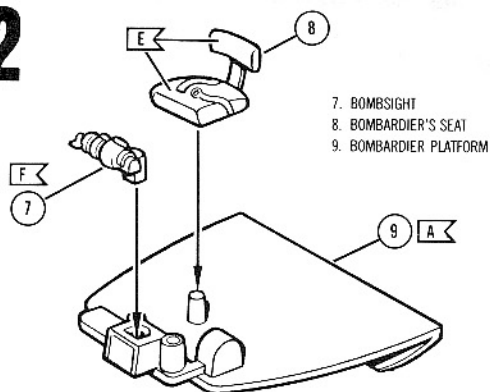
2

7. BOMBSIGHT
 8. BOMBARDIER'S SEAT
 9. BOMBARDIER PLATFORM

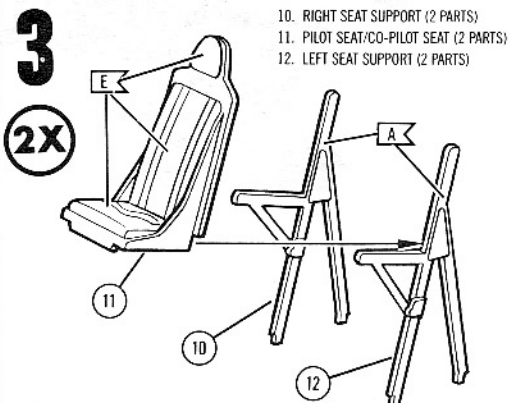
3

10. RIGHT SEAT SUPPORT (2 PARTS)
 11. PILOT SEAT/CO-PILOT SEAT (2 PARTS)
 12. LEFT SEAT SUPPORT (2 PARTS)

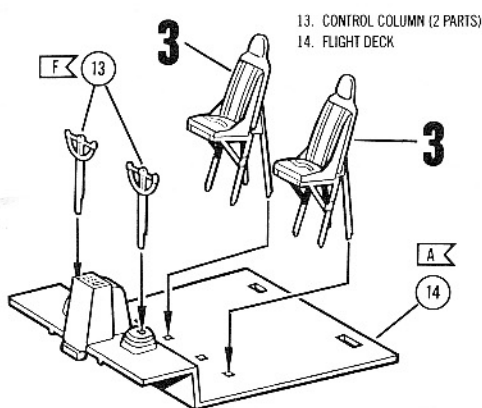
4

13. CONTROL COLUMN (2 PARTS)
 14. FLIGHT DECK

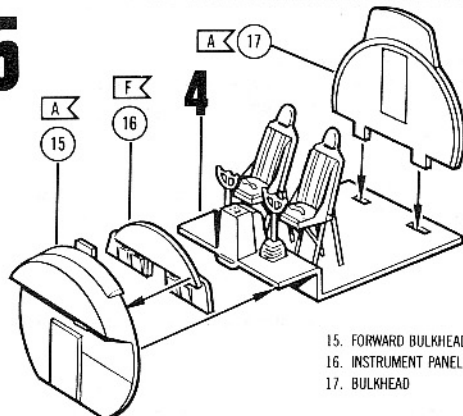
5

15. FORWARD BULKHEAD
 16. INSTRUMENT PANEL
 17. BULKHEAD

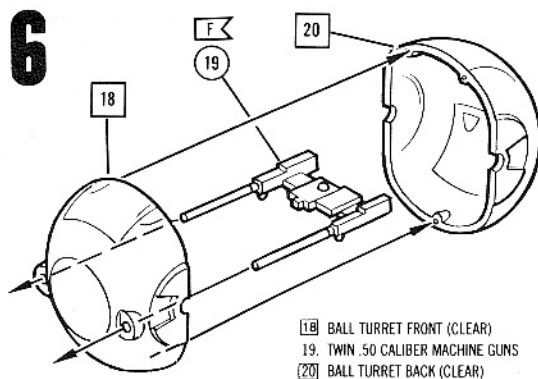
6

- 18 BALL TURRET FRONT (CLEAR)
 19. TWIN .50 CALIBER MACHINE GUNS
 20 BALL TURRET BACK (CLEAR)

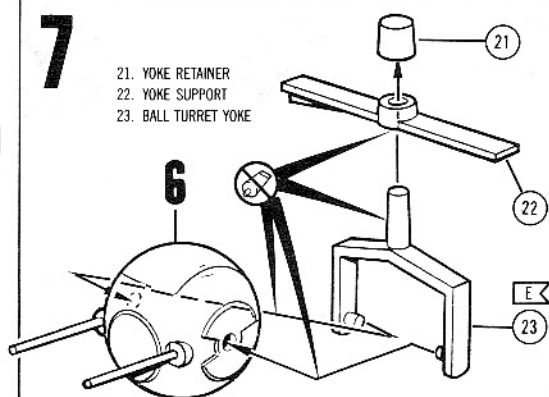
7

21. YOKE RETAINER
 22. YOKE SUPPORT
 23. BALL TURRET YOKE

8

24. .50 CALIBER MACHINE GUN

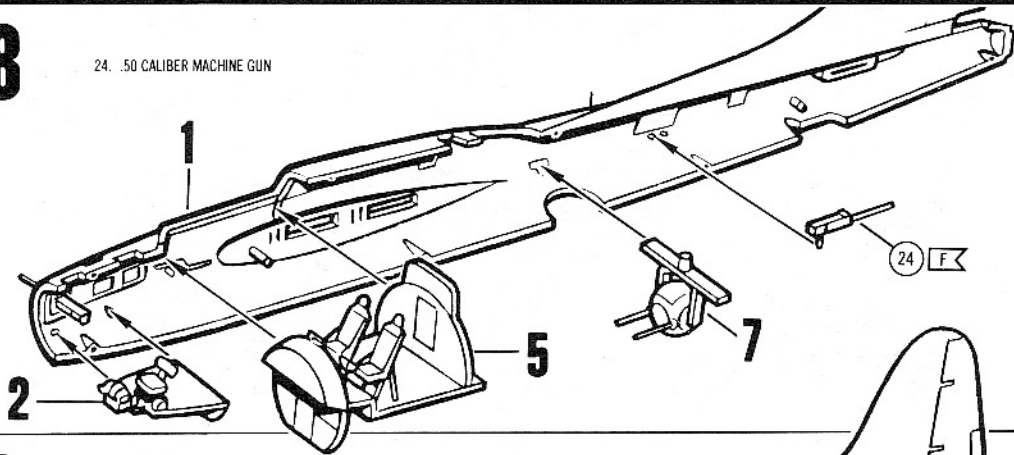

9

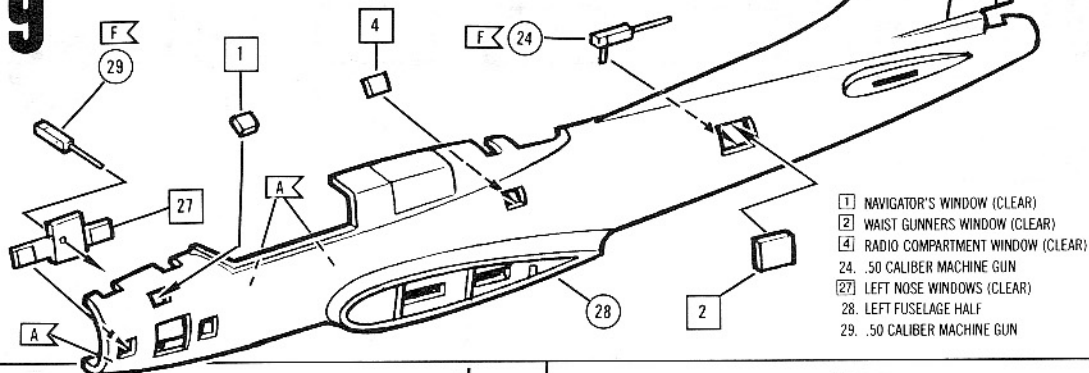

- 1 NAVIGATOR'S WINDOW (CLEAR)
- 2 WAIST GUNNERS WINDOW (CLEAR)
- 4 RADIO COMPARTMENT WINDOW (CLEAR)
- 24 .50 CALIBER MACHINE GUN
- 27 LEFT NOSE WINDOWS (CLEAR)
- 28 LEFT FUSELAGE HALF
- 29 .50 CALIBER MACHINE GUN

10

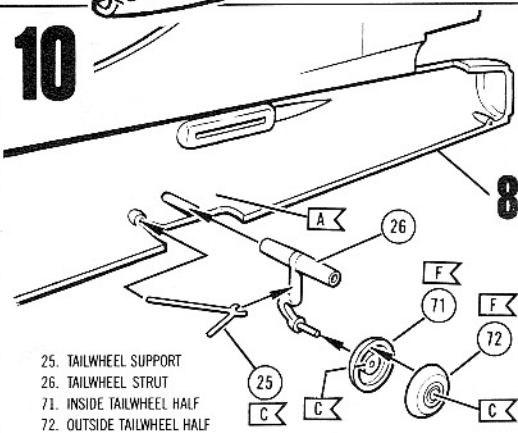

- 25. TAILWHEEL SUPPORT
- 26. TAILWHEEL STRUT
- 71. INSIDE TAILWHEEL HALF
- 72. OUTSIDE TAILWHEEL HALF

11

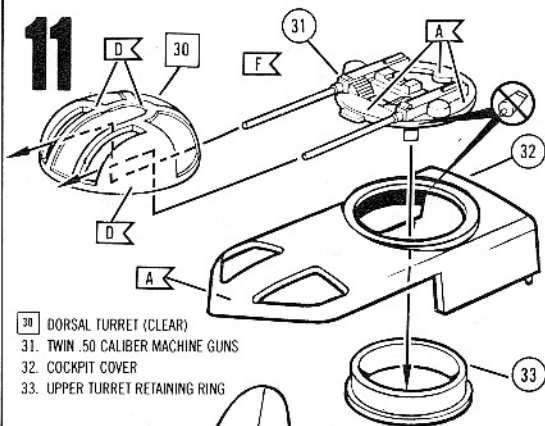

- 30 DORSAL TURRET (CLEAR)
- 31. TWIN .50 CALIBER MACHINE GUNS
- 32. COCKPIT COVER
- 33. UPPER TURRET RETAINING RING

12

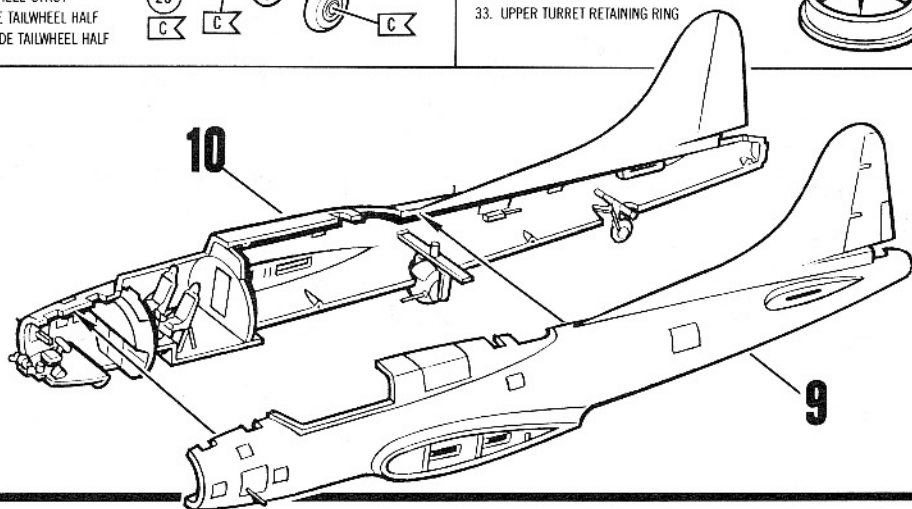

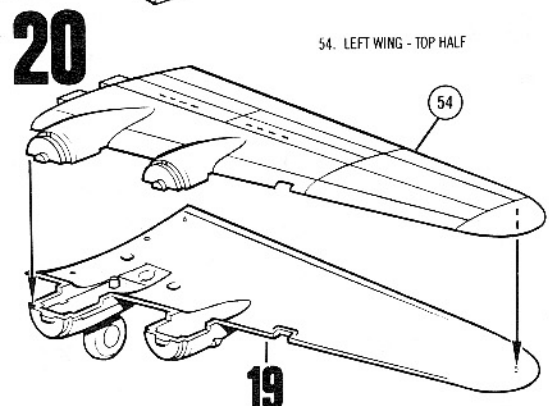
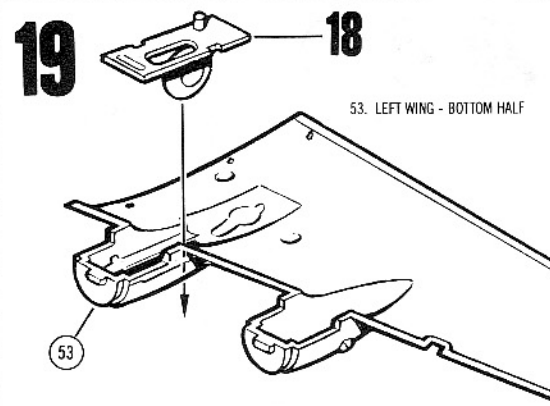
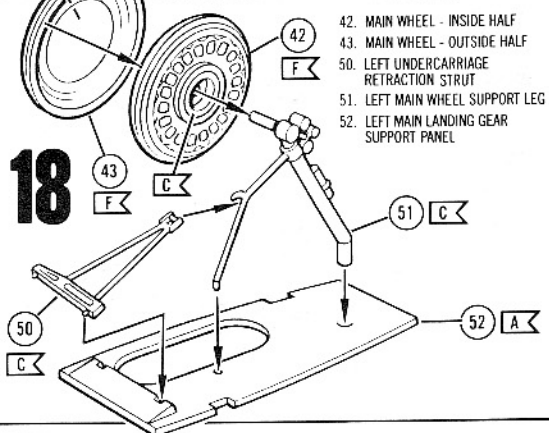
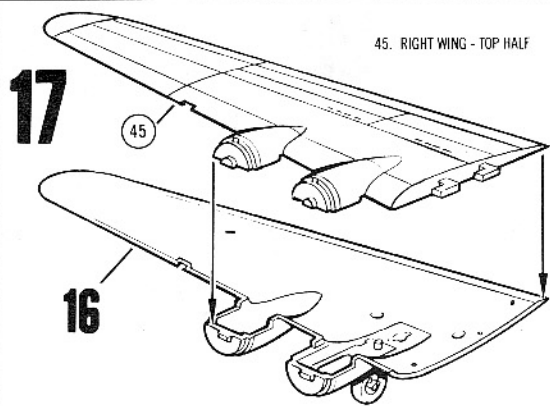
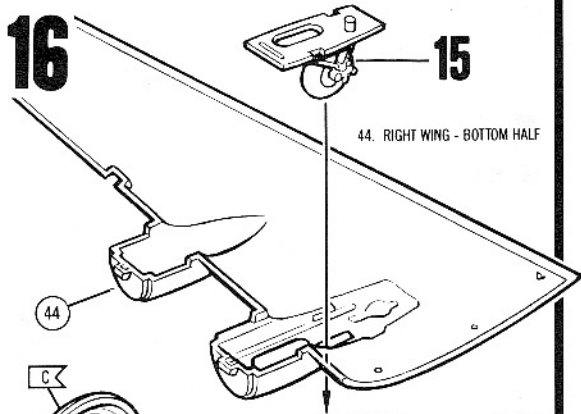
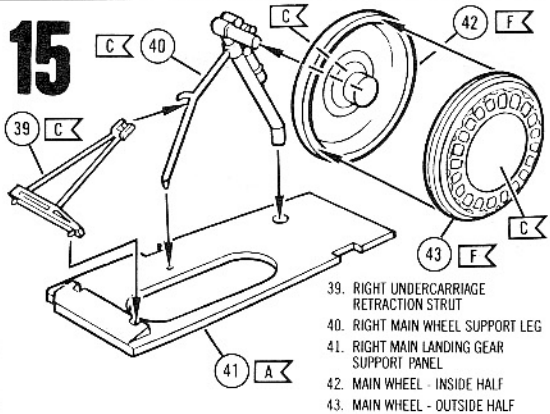
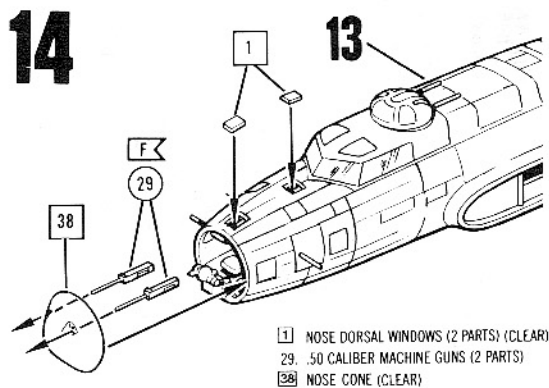
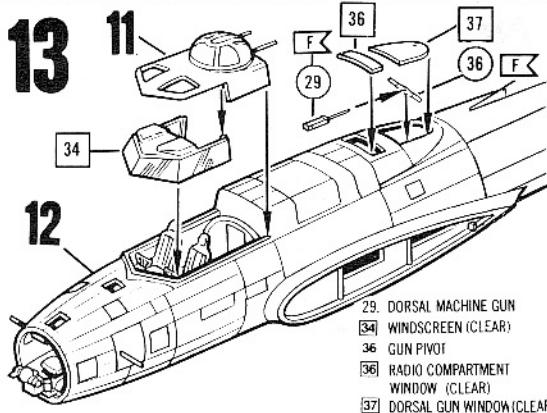

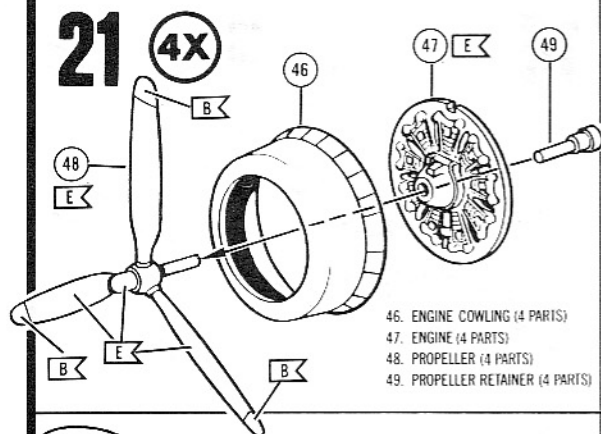
21 **4X**

46. ENGINE COWLING (4 PARTS)
 47. ENGINE (4 PARTS)
 48. PROPELLER (4 PARTS)
 49. PROPELLER RETAINER (4 PARTS)

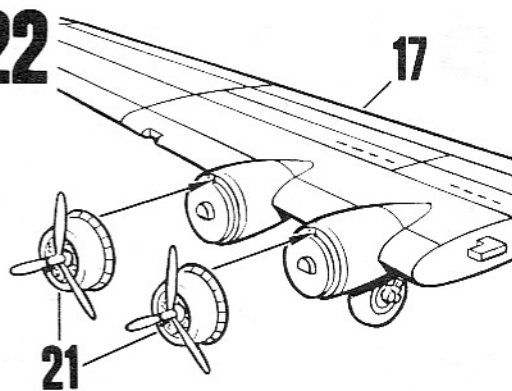
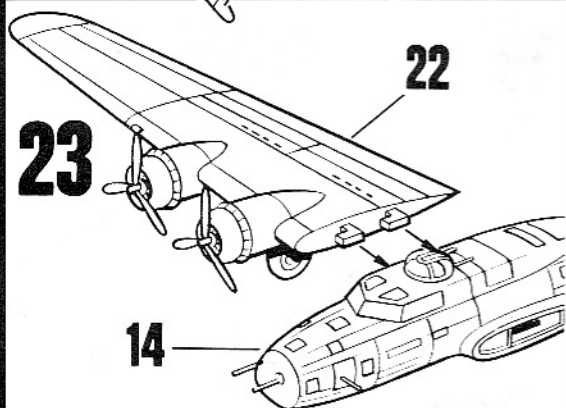
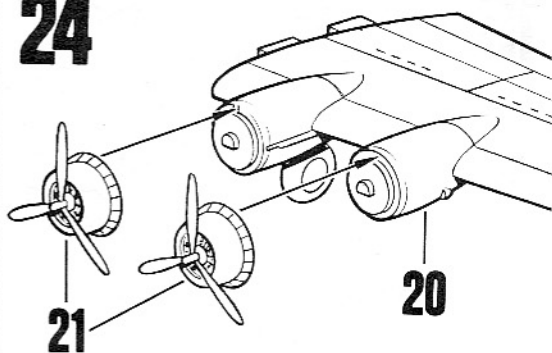
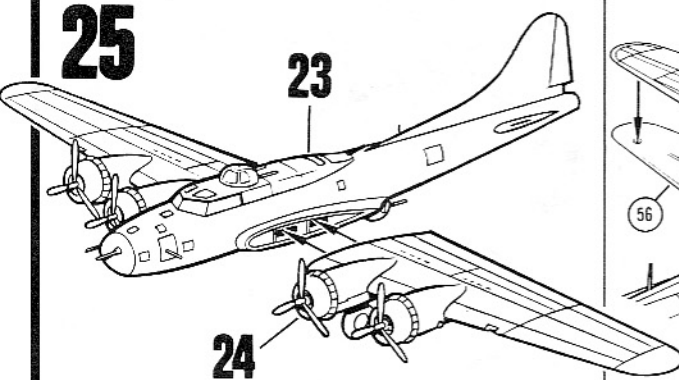
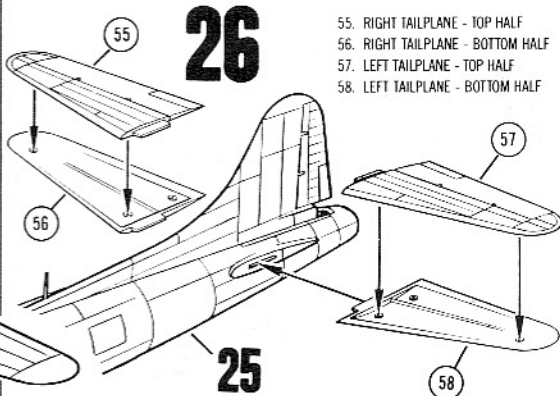
22**23****24****25****26**

55. RIGHT TAILPLANE - TOP HALF
 56. RIGHT TAILPLANE - BOTTOM HALF
 57. LEFT TAILPLANE - TOP HALF
 58. LEFT TAILPLANE - BOTTOM HALF

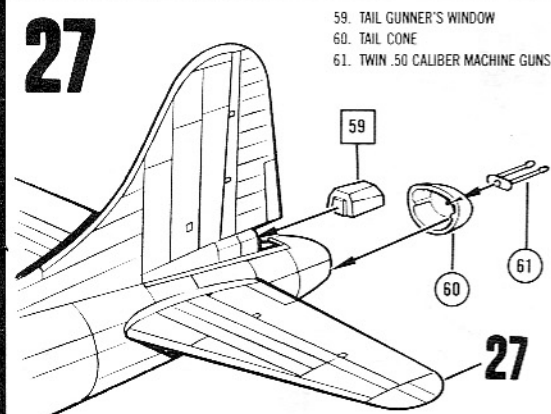
27

59. TAIL GUNNER'S WINDOW
 60. TAIL CONE
 61. TWIN .50 CALIBER MACHINE GUNS

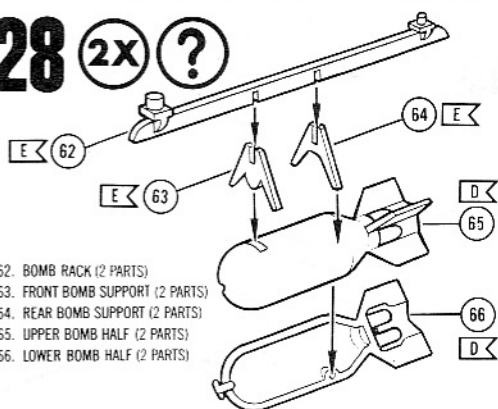
28 **2X** **?**

62. BOMB RACK (2 PARTS)
 63. FRONT BOMB SUPPORT (2 PARTS)
 64. REAR BOMB SUPPORT (2 PARTS)
 65. UPPER BOMB HALF (2 PARTS)
 66. LOWER BOMB HALF (2 PARTS)

29

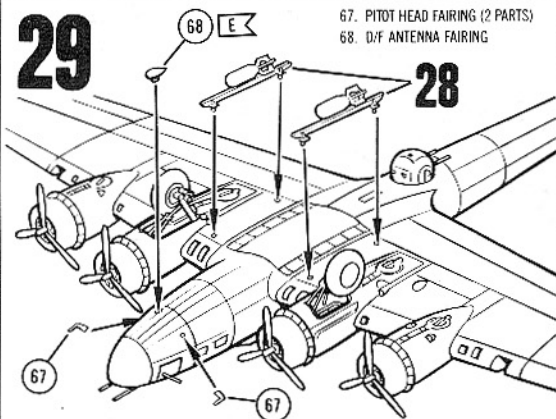

30

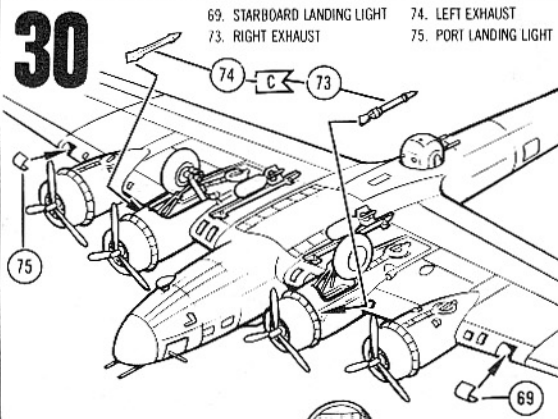

31



MATT OLIVE GREEN
VERT OLIVE MAT
VERDE OLIVA MATE

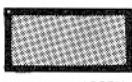

MATT DARK GREEN
VERT FONCE MAT
VERDE OSCURO MATE

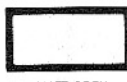

MATT GREY
GRIS MAT
GRIS MATE

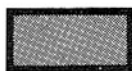

MATT BLACK
NOIR MAT
NEGRO MATE

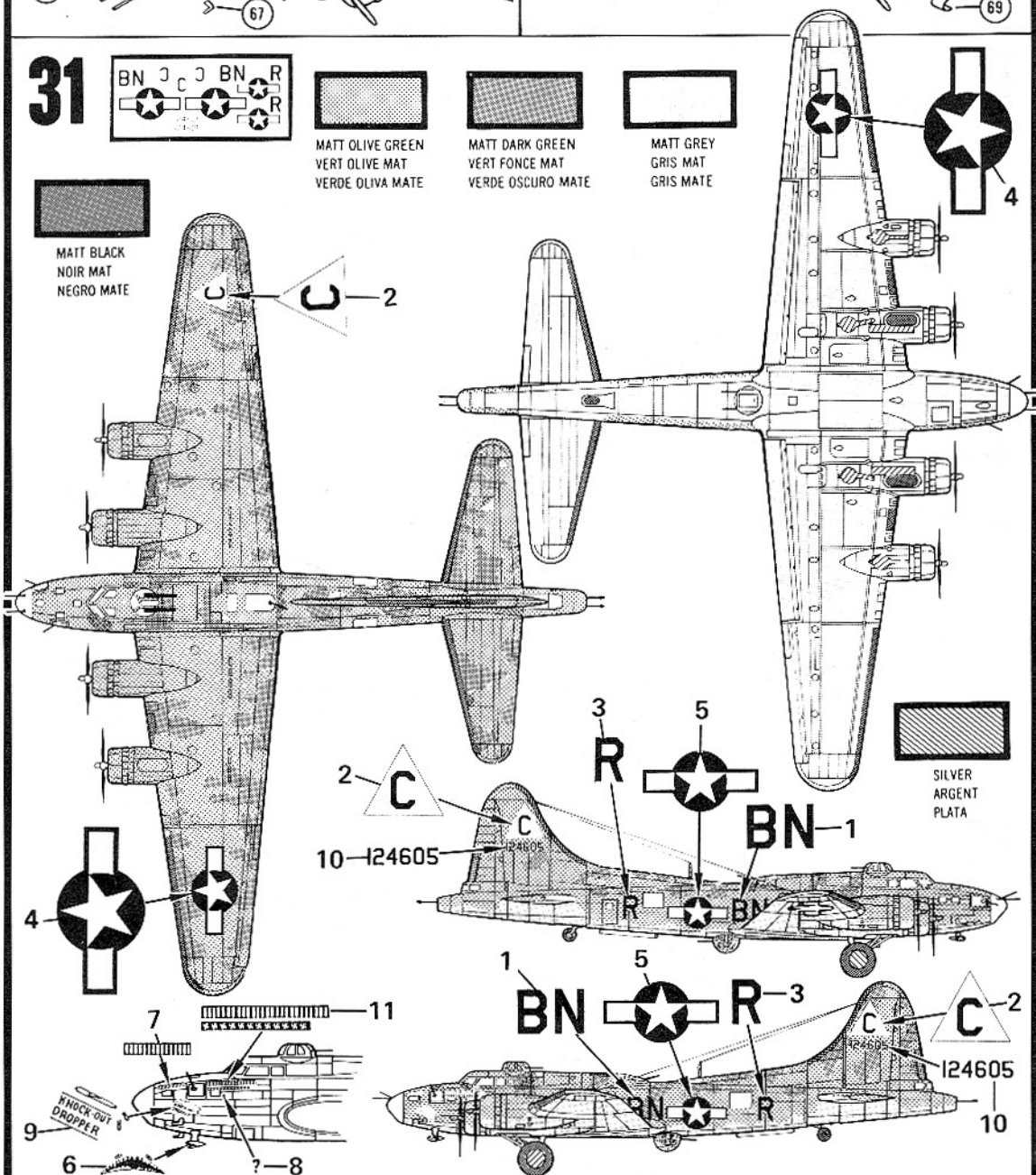



8 ?



KNOCK-OUT
DROPPER

CB

10 124605
124605

